

Operation Manual

Sewing and Embroidery Machine

Product Code: 882-W40/W42

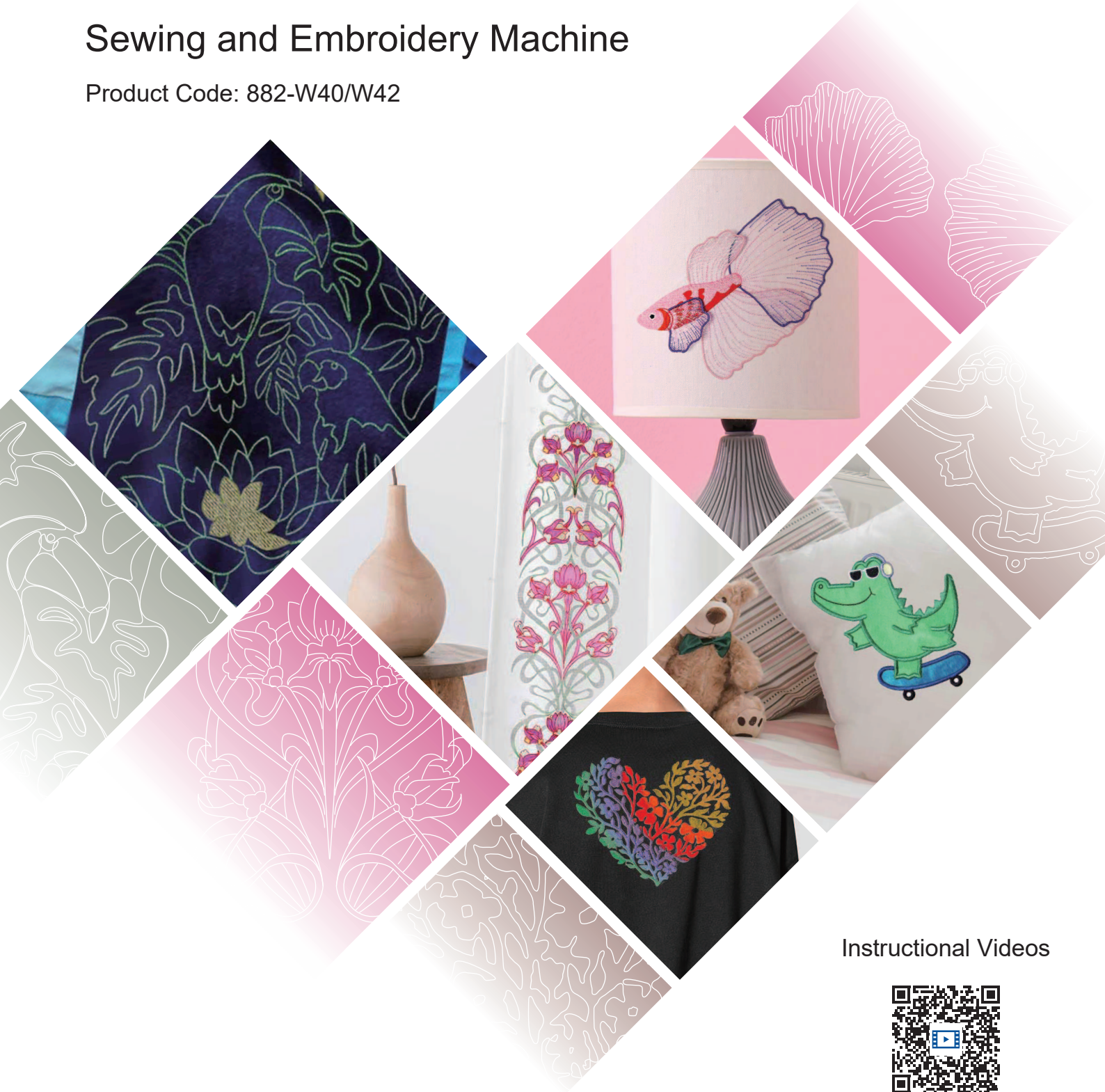

Instructional Videos



<https://s.brother/cvdae/>

Be sure to read this document before using the machine.
We recommend that you keep this document nearby for future reference.
The latest manuals are available at Brother support website (<https://s.brother/cpdae/>).

INTRODUCTION

Thank you for purchasing this machine. Before using this machine, carefully read the "IMPORTANT SAFETY INSTRUCTIONS", and then study this manual for the correct operation of the various functions. In addition, after you have finished reading this manual, keep it where it can quickly be accessed for future reference.

IMPORTANT SAFETY INSTRUCTIONS

Please read these safety instructions before attempting to use the machine.

DANGER

- To reduce the risk of electric shock

- 1** Always unplug the machine from the electrical outlet immediately after using, when cleaning, making any user servicing adjustments mentioned in this manual, or if you are leaving the machine unattended.

WARNING

- To reduce the risk of burns, fire, electrical shock, or injury to persons.

- 2** Always unplug the machine from the electrical outlet when making any adjustments mentioned in the instruction manual.

- To unplug the machine, switch the machine to the symbol "O" position to turn it off, then grasp the plug and pull it out of the electrical outlet. Do not pull on the cord.
- Plug the machine directly into the electrical outlet. Do not use an extension cord.
- Always unplug your machine if there is a power failure.

- 3** Electrical Hazards:

- This machine should be connected to an AC power source within the range indicated on the rating label. Do not connect it to a DC power source or inverter. If you are not sure what kind of power source you have, contact a qualified electrician.

- This machine is approved for use in the country of purchase only.

- 4** Fire Hazards:

Do not use flammable substances, any type of spray, or an organic solvent/liquid containing alcohol or ammonia to clean the inside or outside of the product. Doing so could cause a fire.

- 5** Never operate this machine if it has a damaged

cord or plug, is not working properly, has been stepped on, has been dropped or damaged, or if water has been spilled on it or its accessories. Consult the nearest authorized Brother dealer for examination, repair, electrical or mechanical adjustment.

- While the machine is stored or in use if you notice anything unusual, such as an odor, heat, discoloration or deformation, stop using the machine immediately and unplug the power cord.
- When transporting the machine, be sure to carry it by its handle. Lifting the machine by any other part may damage the machine or result in the machine falling, which could cause injuries.
- When lifting the machine, be careful not to make any sudden or careless movements, which may cause a personal injury.

- 6** Always keep your work area clear:

- Do not install or use in areas where explosive or electrically conductive dusts are generated.
- Never operate the machine with any air openings blocked. Keep ventilation openings of the machine and foot controller free from the build up of lint, dust, and loose cloth.
- Do not store objects on the foot controller.
- Never drop or insert foreign object into any opening.
- Do not operate where aerosol (spray) products are being used or where oxygen is being administered.
- Do not use the machine near a heat source, such as a stove or iron; otherwise, the machine, power cord or garment being sewn may ignite, resulting in fire or an electric shock.
- Do not place this machine on an unstable surface, such as an unsteady or slanted table, otherwise the machine may fall, resulting in injuries.

7 Special care is required when sewing:

- Always pay close attention to the needle. Do not use bent or damaged needles.
- Keep fingers away from all moving parts. Special care is required around the machine needle.
- Switch the machine to the symbol “O” position to turn it off when making any adjustments in the needle area.
- Do not use a damaged or incorrect needle plate, as it could cause the needle to break.
- Do not push or pull the fabric when sewing, and follow careful instruction when free motion stitching so that you do not deflect the needle and cause it to break.

8 This machine is not a toy:

- Your close attention is necessary when the machine is used by or near children.
- This product contains small parts. Keep the product out of the reach of children to prevent accidental ingestion of small parts.
- The plastic bag that this machine was supplied in should be kept out of the reach of children or disposed of. Never allow children to play with the bag due to the danger of suffocation.
- Do not use the seam ripper in any other way than how it is intended.
- Do not use outdoors.

9 For a longer service life:

- When using and storing this machine, avoid direct sunlight and high humidity locations. Do not use or store the machine near a space heater, iron, halogen lamp, or other hot objects.
- Do not use cleansers or organic solvents, such as thinner, petroleum ether or alcohol, to clean the machine. Otherwise, the finish may peel off or become scratched.
- Always consult the Operation Manual when replacing or installing any assemblies, the presser feet, needle, or other parts to assure correct installation.

10 For repair or adjustment:

- If the light unit is damaged, it must be replaced by an authorized Brother dealer.
- In the event a malfunction occurs or adjustment is required, first follow the troubleshooting table in the back of the Operation Manual to inspect and adjust the machine yourself. If the problem persists, please consult your local authorized Brother dealer.

Use this machine only for its intended use as described in the manual.

Use accessories recommended by the manufacturer as contained in this manual.

The contents of this manual and specifications of this product are subject to change without notice.

**SAVE THESE
INSTRUCTIONS**
**This machine is intended
for household use.**

FOR USERS IN COUNTRIES EXCEPT EUROPEAN COUNTRIES

This appliance is not intended for use by persons (including children) with reduced physical, sensory or mental capabilities, or lack of experience and knowledge, unless they have been given supervision or instruction concerning use of the appliance by a person responsible for their safety. Children should be supervised to ensure that they do not play with the appliance.

FOR USERS IN EUROPEAN COUNTRIES

This appliance can be used by children aged from 8 years and above and persons with reduced physical, sensory or mental capabilities or lack of experience and knowledge if they have been given supervision or instruction concerning use of the appliance in a safe way and understand the hazards involved. Children shall not play with the appliance. Cleaning and user maintenance shall not be made by children without supervision.

FOR USERS IN THE UK, EIRE, MALTA AND CYPRUS ONLY

IMPORTANT

- In the event of replacing the plug fuse, use a fuse approved by ASTA to BS 1362, i.e. carrying the  mark, rating as marked on plug.
- Always replace the fuse cover. Never use plugs with the fuse cover omitted.
- If the available electrical outlet is not suitable for the plug supplied with this equipment, you should contact your authorized Brother dealer to obtain the correct lead.

Federal Communications Commission (FCC) Supplier's Declaration of Conformity (For U.S.A. Only)

Responsible Party: Brother International Corporation
200 Crossing Boulevard
P.O. Box 6911
Bridgewater, NJ 08807-0911
U.S.A.
TEL : (908) 704-1700

declares that the product

Product Name: Brother Sewing Machine
Model Number: EV1, EV1-LE

This device complies with Part 15 of the FCC Rules.

Operation is subject to the following two conditions:

(1) this device may not cause harmful interference, and (2) this device must accept any interference received, including interference that may cause undesired operation.

This equipment has been tested and found to comply with the limits for a Class B digital device, pursuant to Part 15 of the FCC Rules. These limits are designed to provide reasonable protection against harmful interference in a residential installation. This equipment generates, uses, and can radiate radio frequency energy and, if not installed and used in accordance with the instructions, may cause harmful interference to radio communications. However, there is no guarantee that interference will not occur in a particular installation. If this equipment does cause harmful interference to radio or television reception, which can be determined by turning the equipment off and on, the user is encouraged to try to correct the interference by one or more of the following measures:

- Reorient or relocate the receiving antenna.
- Increase the separation between the equipment and receiver.
- Connect the equipment into an outlet on a circuit different from that to which the receiver is connected.
- Consult the authorized Brother dealer or an experienced radio/TV technician for help.
- This transmitter must not be co-located or operated in conjunction with any other antenna or transmitter.

Important

Changes or modifications not expressly approved by Brother Industries, Ltd. could void the user's authority to operate the equipment.

This equipment complies with FCC/IC radiation exposure limits set forth for an uncontrolled environment and meets the FCC radio frequency (RF) Exposure Guidelines and RSS-102 of the IC radio frequency (RF) Exposure rules. This equipment should be installed and operated keeping the radiator at least 20cm or more away from person's body.

For Users in Canada

This device complies with Industry Canada's licence-exempt RSSs. Operation is subject to the following two conditions:

- (1) This device may not cause interference; and
- (2) This device must accept any interference, including interference that may cause undesired operation of the device.

This equipment complies with FCC/IC radiation exposure limits set forth for an uncontrolled environment and meets the FCC radio frequency (RF) Exposure Guidelines and RSS-102 of the IC radio frequency (RF) Exposure rules. This equipment should be installed and operated keeping the radiator at least 20cm or more away from person's body.

For Users in Mexico

The operation of this equipment is subject to the following two conditions:

- (1) it is possible that this equipment or device may not cause harmful interference, and
- (2) this equipment or device must accept any interference, including interference that may cause undesired operation.

La operación de este equipo está sujeta a las siguientes dos condiciones:

- (1) es posible que este equipo o dispositivo no cause interferencias perjudiciales y
- (2) este equipo o dispositivo debe aceptar cualquier interferencia, incluyendo la que pueda causar su operación no deseada.

Declaration of Conformity (Europe and Turkey only)

We, Brother Industries, Ltd. 15-1 Naeshiro-cho, Mizuho-ku, Nagoya 467-8561 Japan declare that this product is in conformity with the essential requirements of all relevant directives and regulations applied within the European Community.

The Declaration of Conformity (DoC) can be downloaded from Brother support website.

Visit support.brother.com

Declaration of Conformity for RE Directive 2014/53/EU (Europe and Turkey only) (Applicable to models with radio interfaces)

We, Brother Industries, Ltd. 15-1 Naeshiro-cho, Mizuho-ku, Nagoya 467-8561 Japan declare that these products are in conformity with the provisions of the RE Directive 2014/53/EU.

The Declaration of Conformity (DoC) can be downloaded from Brother support website. Visit support.brother.com

Wireless LAN (Models with Wireless LAN function only)

This machine supports wireless interface.
Frequency band(s): 2400-2483.5 MHz
Maximum radio-frequency power transmitted in the
frequency band(s): Less than 20 dBm(e.i.r.p)

UK Declaration of Conformity (Great Britain only)

We, Brother Industries, Ltd. 15-1 Naeshiro-cho, Mizuho-ku, Nagoya 467-8561 Japan declare that these products are in conformity with the relevant UK legislation.

The Declaration of Conformity (DoC) can be downloaded from Brother support website. Visit support.brother.com

UK Declaration of Conformity for Radio Equipment Regulation 2017 (Great Britain only) (Applicable to models with radio interfaces)

We, Brother Industries, Ltd. 15-1 Naeshiro-cho, Mizuho-ku, Nagoya 467-8561 Japan declare that these products are in conformity with the provisions of the Radio Equipment Regulation 2017.

The Declaration of Conformity (DoC) can be downloaded from Brother support website. Visit support.brother.com

UK Statements of Compliance for the Product Security and Telecommunications Infrastructure (Security Requirements for Relevant Connectable Products) Regulations 2023 (Great Britain only)

We, Brother Industries, Ltd. 15-1, Naeshiro-cho, Mizuho-ku, Nagoya 467-8561, Japan declare that these products are in conformity with the provisions of the Product Security and Telecommunications Infrastructure (Security Requirements for Relevant Connectable Products) Regulations 2023. A copy of the Statements of Compliance can be downloaded from Brother support website. Visit support.brother.com

For Users in Norway

- * This subsection does not apply for the geographical area within a radius of 20 km from the centre of Ny-Alesund on Svalbard.
- * Dette underavsnittet gjelder ikke for det geografiske området innenfor en radius av 20 km fra sentrum av Ny-Ålesund på Svalbard.

Laser Notices (For U.S.A. only)

Laser Safety

This sewing machine is certified as a Class 1 laser product under the U.S. Department of Health and Human Services (DHHS) Radiation Performance Standard according to the Radiation Control for Health and Safety Act of 1968. This means that the sewing machine does not produce hazardous laser radiation.

IEC 60825-1 Specification

This machine is a Class 1 laser product as defined in IEC 60825-1:2014 specification.

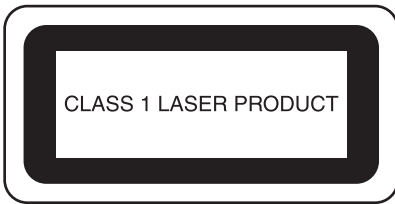

The invisible laser beam emitted by the laser unit installed in this stitch regulator is restricted to an output at a safe level. The stitch regulator contains 0.6-milliwatt, 840-860 nanometer wavelength, 1.5 mrad divergence angle, pulse duration 26 μ s, pulse frequency 10 kHz, laser module. However, eye damage may result from disassembling or altering this stitch regulator. Safety precautions have been designed to prevent any possible laser beam exposure to the operator.

FDA Regulations

U.S. Food and Drug Administration (FDA) has implemented regulations for laser products manufactured on and after August 2, 1976. Compliance is mandatory for products marketed in the United States. The label shown on the back of the sewing machine indicates compliance with the FDA regulations and must be attached to laser products marketed in the United States.

Brother Industries, Ltd.
15-1, Naeshiro-cho, Mizuho-ku, Nagoya 467-8561,
JAPAN
This product complies with FDA performance standards for laser products except for conformance with IEC 60825-1 Ed. 3., as described in Laser Notice No. 56, dated May 8, 2019.

⚠ CAUTION

- Use of controls, adjustments or the performance of procedures other than those specified in this manual may result in hazardous radiation exposure.

Laser Notices (For European countries)

EN 60825-1:2014+A11:2021 and EN 50689:2021 Specification

This machine is Class 1 consumer laser product in EN 60825-1:2014+A11:2021 and EN 50689:2021 specifications.

This laser measures the direction and amount of movement of the cloth.



Laser Notices (For countries except U.S.A. and European countries)

IEC 60825-1 Specification

This machine is a Class 1 laser product as defined in IEC 60825-1:2014 specification.

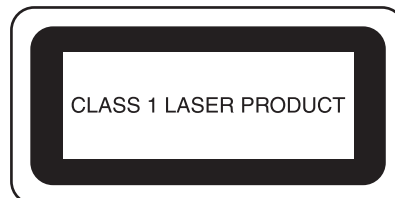

For countries except U.S.A.

The invisible laser beam emitted by the laser unit installed in this stitch regulator is restricted to an output at a safe level. The stitch regulator contains 0.6-milliwatt, 840-860 nanometer wavelength, 1.5 mrad divergence angle, pulse duration 26 μ s, pulse frequency 10 kHz, laser module. However, eye damage may result from disassembling or altering this stitch regulator. Safety precautions have been designed to prevent any possible laser beam exposure to the operator.

⚠ CAUTION

- This machine has a Laser module in the stitch regulator. The stitch regulator should not be opened under any circumstances.
- Use of controls, adjustments or the performance of procedures other than those specified in this manual may result in hazardous radiation exposure.

Legal limitations for copying (United States/Canada)

Observe all copyright laws when using this product. Color reproductions of certain documents are illegal and may result in either criminal or civil liability. This memorandum is intended to be a guide rather than a complete listing of every possible prohibition. In case of doubt, we suggest that you check with counsel as to any particular questionable documents.

The following documents issued by the United States/Canadian Government or any of its Agencies may not be copied:

- Money
- Bonds or other certificates of indebtedness
- Certificates of Deposit
- Internal Revenue Stamps (canceled or uncanceled)
- Selective Service or draft papers
- Passports
- United States/Canadian Postage Stamps (canceled or uncanceled)
- Food Stamps
- Immigration Papers
- Checks or drafts drawn by Governmental agencies
- Identifying badges or insignias

Copyrighted works cannot be copied. Sections of a copyrighted work can be copied for 'fair use'. Multiple copies would indicate improper use. Works of art should be considered the equivalent of copyrighted works.

Unlawful Use of Scanning Equipment (Other countries except United States/Canada)

It is an offence to make reproductions of certain items or documents with the intent to commit fraud. The following is a non-exhaustive list of documents which it may be unlawful to produce copies of. We suggest you check with your legal adviser and/or the relevant legal authorities if in doubt about a particular item or document:

- Currency
- Bonds or other certificates of debt
- Certificates of Deposit
- Armed forces service or draft papers
- Passports
- Postage stamps (cancelled or uncanceled)
- Immigration papers
- Welfare documents
- Cheques or drafts drawn by governmental agencies
- Identifying badges or insignias

Copyrighted works cannot be copied lawfully, subject to the "fair dealing" exception relating to sections of a copyrighted work. Multiple copies would indicate improper use. Works of art should be considered the equivalent of copyrighted works.

WARNING SIGN

■ Spool Stand

The warning label is attached to the bottom.

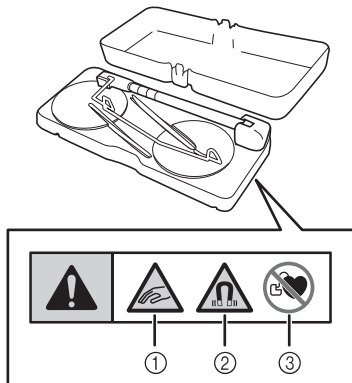

This product contains magnets.

- ① Be careful not to pinch your fingers or any objects between the spool stand and the upper cover of the machine.
- ② Be sure to keep the magnets away from precision electronics, computer disks, credit cards with a magnetic stripe, etc.
- ③ Do not use the spool stand if you have a pacemaker.

■ Stitch Regulator

The following caution sign pertains to the stitch regulator.

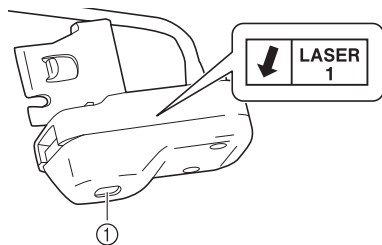

- ① Laser emitting window

⚠ CAUTION

- An invisible laser is emitted from the window indicated by the arrow. Although this product complies with Class 1 laser product regulations to ensure safety, do not look into the laser emitting window since that may be harmful to your eyes.

TRADEMARKS

WPA™, WPA2™ and WPA3™ are trademarks of Wi-Fi Alliance®.

QR Code is a registered trademark of DENSO WAVE INCORPORATED.

Any trade names and product names of companies appearing on Brother products, related documents and any other materials are all trademarks or registered trademarks of those respective companies.

PRECAUTION FOR WIRELESS CONNECTION

Make sure you use a router or firewall when connecting your machine to the Internet to protect it against unauthorized access from the Internet.

Outstanding Features

■ Stitch Regulator

The stitch regulator allows free-motion quilting and free-motion basting with a set stitch length. (page 114)

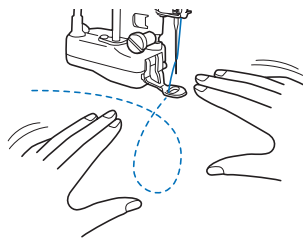

■ Picture Play Embroidery Function

A photo can be converted into embroidery data. (page 177)



■ Editing the Embroidery Pattern Projected Onto Fabric

You can project the embroidery pattern onto the fabric, then edit it. (page 154)

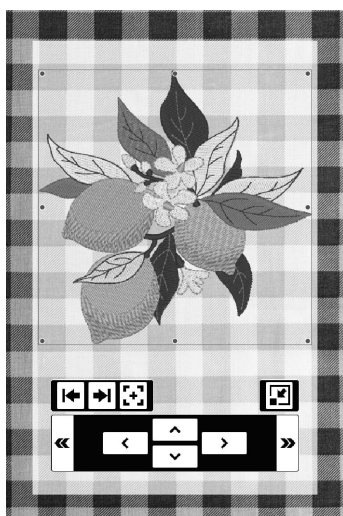

■ Projecting the Guidelines with the Projector

With the guideline function, sewing can easily be done by following the lines and marks projected onto the fabric. (page 65)

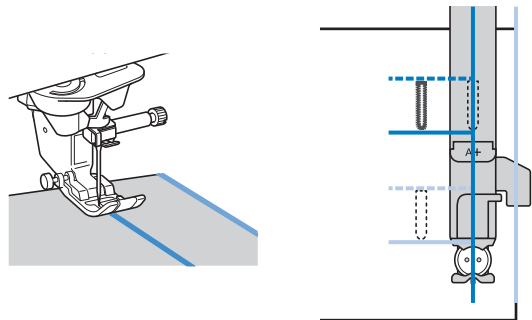

■ Instructional Videos

The instructional videos are available online and can be viewed on any mobile device or computer.



<https://s.brother/cvdae/>

You can also access them using the QR code that appears in the screen. (page 29)

■ Embroidery Frames and Support Table

Embroidery frame (465 mm × 297 mm (approx. 18-1/4 inches × 11-5/8 inches)) can be used. (page 128)

Using the support table to support the embroidery frame and fabric allows you to maintain stitching quality. (page 126)

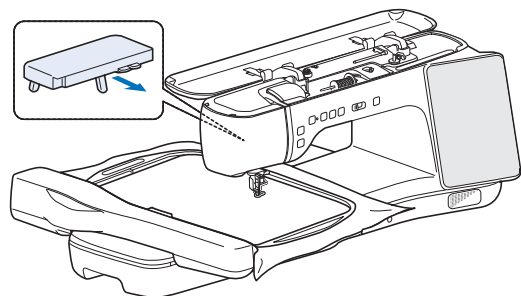

■ Other Functions

- Filtering the embroidery patterns (page 135)
- Voice Guidance (page 28)

CONTENTS

Chapter 1 Getting Ready	13		
Names of Machine Parts	13		
Included Accessories	14		
Using the Accessory Case	14		
Using the Flat Bed Attachment	15		
Using the Multi-purpose Screwdriver	15		
Using the Dual Purpose Stylus	15		
Turning the Machine On/Off	16		
LCD Screen	17		
Tooltips	17		
Using a USB Mouse (Commercially Available)	17		
Home Page Screen	18		
Sewing Screens	19		
Settings Screen	22		
Machine Help Screen	29		
Wireless Network Connection Functions	31		
Available Operations	31		
Set Up the Wireless Network Connection	32		
Preparing the Needle and Thread	34		
Fabric/Thread/Needle Combinations	34		
How to Use the Spool Cap and Spool Net	35		
Changing the Needle	36		
Winding/Installing the Bobbin	37		
Winding the Bobbin	37		
Setting the Bobbin	40		
Pulling Up the Bobbin Thread	41		
Upper Threading	42		
Upper Threading	42		
Using the Spool Stand	45		
Changing the Presser Foot	48		
Replacing the Presser Foot	48		
Attaching the Presser Foot with the Included Adapter	48		
Using the Compact Dual Feed Foot	49		
Chapter 2 Sewing Basics	51		
Sewing	51		
Stitch Types	51		
Basic Sewing	51		
Using Advanced Multi-Function Foot Controller	53		
Sewing Reverse/Reinforcement Stitches	55		
Automatic Reverse/Reinforcement Stitching	56		
Automatic Thread Cutting	58		
Automatic Presser Foot Lift Function	58		
Automatic Presser Foot Raising Function	59		
Returning to the Beginning of the Stitch Pattern	59		
Editing Character/Decorative Stitches	59		
Stitch Settings	61		
Setting the Stitch Width/Stitch Length/"L/R Shift"	61		
Setting the Thread Tension	62		
Saving the Utility Stitch Settings	63		
Using the Memory Function (Sewing)	64		
Saving Character/Decorative Stitch Patterns	64		
Retrieving Stitch Patterns	64		
Projecting the Guidelines onto the Fabric	65		
Specify the Guidelines	65		
Piecing Using Guidelines	67		
Buttonhole Guidelines	68		
Using the Projector with the Dual Purpose Stylus	70		
Operating the Projector with the Dual Purpose Stylus	70		
Projecting/Editing the Stitch Pattern with the Projector	70		
Useful Functions	72		
Pivoting	72		
Using the Knee Lifter	72		
Automatic Fabric Sensor System (Automatic Presser Foot Pressure)	73		
Changing the Stitch Width During Sewing	73		
Checking the Needle Location in the Screen	74		
Needle Position - Stitch Placement	75		
Specifying the Sewing End Point	75		
Useful Sewing Tips	78		
Sewing Tips	78		
Sewing Various Fabrics	78		
Sewing Character/Decorative Stitches	80		
Chapter 3 Various Stitches	81		
Utility Stitches	81		
Straight Stitches	81		
Zigzag Stitches	83		
Overcasting	84		
Blind Hem Stitches	85		
One-Step Buttonholes	87		
Four-Step Buttonholes	91		
Button Sewing	92		
Bar Tacks	93		
Darning	93		
Eyelet	94		
Basting	95		
Zipper Insertion	95		
Stitch Tapering Function	98		
Couching	101		
Multi-directional Sewing	103		
Making Step Stitch Patterns	104		
Making Adjustments	105		
Sewing with a Twin Needle	106		
Sewing Technique	107		
Quilting	110		
Piecing	110		
Quilting with the Compact Dual Feed Foot	111		
Free Motion Quilting	111		
Free-Motion Quilting/Basting with the Stitch Regulator	114		
Hand-look Quilting	119		
MY CUSTOM STITCH	120		
Designing a Stitch	120		
Entering Stitch Data	121		
Using the Memory Function (MY CUSTOM STITCH)	123		
Chapter 4 Basic Embroidery	125		
Embroidering Preparation	125		
Embroidery Step by Step	125		
Attaching Embroidery Foot "W"	125		
Attaching the Embroidery Unit	126		
Hooping the Fabric in the Embroidery Frame	127		
Attaching the Embroidery Frame	131		
Embroidering Attractive Finishes	132		
Embroidering Patterns	134		
Embroidery Pattern Categories	134		
Selecting Embroidery Patterns	134		
Filtering the Embroidery Patterns	135		
Selecting Frame Patterns	136		
Selecting Buttonhole/Eyelet Patterns	136		
Selecting Alphabet Character Patterns	137		
Confirming the Pattern Position	139		
Embroidering Patterns	140		
Key Functions (Embroidery)	142		
Embroidery Edit Screen	142		
Character Pattern Editing Screen	144		
Embroidery Screen	145		
Editing Patterns	146		
Changing the Size of the Pattern	146		
Combining Patterns	147		
Selecting Multiple Patterns at the Same Time	148		
Grouping Multiple Selected Patterns	149		
Aligning the Embroidery Patterns	149		

Designing Repeated Patterns 150
 Embroidering the Pattern Repeatedly 152
 Previewing the Pattern 153
Checking/Editing the Embroidery Pattern
Projected Onto Fabric 154
 Checking the Embroidery Pattern with the Projector 154
 Using the Dual Purpose Stylus To Edit the Embroidery Pattern
 Projected Onto Fabric (Projector Edit with Stylus) 155
Align the Embroidering Position 157
 Display the Fabric on the Screen 157
 Using the Embroidery Positioning Sticker 159
 Aligning the Pattern and the Needle 160
 Using the Camera View Window 161
Adjustments during the Embroidery
Process 162
 If the Bobbin Runs out of Thread 162
 If the Thread Breaks during Embroidering 163
 If It is Difficult to Thread the Needle or Remove the
 Embroidery Frame 164
 Resuming Embroidery after Turning Off the Power 164
Adjusting Thread Tension..... 165
 Adjusting the Tension of the Upper Thread 165
 Adjusting the Alternate Bobbin Case (with No Color on the
 Adjusting Screw) 166
Using the Memory Function
(Embroidery)..... 167
 Saving Embroidery Patterns 167
 Retrieving Embroidery Patterns 168

Chapter 5 Advanced Embroidery 169

Editing Colors 169
 Changing the Thread Color 169
 Find New Color Schemes with the Color Shuffling
 Function 169
 Thread Color Sorting 170
 Uninterrupted Embroidering (Using a Single Color) 171
Various Embroidering Functions 171
 No Sew Setting 171
 Changing the Embroidering Order of Combined
 Patterns 172
 Basting Embroidery 173
 Embroidering Linked Characters 174
 Print and Stitch Function 175
Picture Play Embroidery Function 177
 Adjusting the Imported Image 177
 Selecting the Conversion Method 181
 Selecting Appropriate Thread Colors and Density 183
Appliqué and Couching..... 184
 Creating an Appliqué Piece 184
 Embroidering the Appliqué Patterns 187
 Using a Frame Pattern to Make an Appliqué 189
 Embroidering Couching Patterns 191
Embroidering Quilting 194
 Creating Quilting Patterns around a Design 194
 Embroidering a Quilting Pattern Across the Entire Fabric
 (Edge-to-Edge Quilt Function) 195
 Embroidering Quilting Border Patterns (Auto Split
 Quilt Sash) 201
 Embroidering Quilting Border Patterns (Semi-Auto Split
 Quilt Sash) 203
 Hexagonal Quilting Borders 208
Using the Camera to Connect Patterns 212
 Embroidering Split Embroidery Patterns 212
 Aligning Pattern Edges 217
Using a Mobile App..... 225
 My Stitch Monitor App 225
 Artspira App 225
 My Design Snap App 225

Chapter 6 My Design Center 227

About My Design Center..... 227
Before Creating Designs..... 227
Create a Stippling Design with the Basic
Procedure..... 227
Key Functions (My Design Center) 230
 Pattern Drawing Screen 230
 Using the Stamp Key..... 231
 Drawing Lines..... 232
 Drawing Regions 232
 Setting the Line Types, Stitch Types and Colors 233
 Setting the Brush Types, Fill Stitch Types and Fill
 Colors 234
 Using the Select Key 235
 Using the Erase Key 235
 Using the Size Key 236
 Importing Motif Stitch Pattern Data or Decorative Fill
 Pattern Data 236
Stitch Settings Screen 238
 Specifying Individual Stitch Settings 238
 Line and Region Settings 239
 Specifying Global Stitch Settings 241
Create the Pattern Using Scanned Images
or Image Data Files..... 241
 Using the Scanning Frame 241
 Scanning the Background Image 243
 Importing the Background Image 244
 Create a Pattern with Line Conversion..... 245
 Create a Pattern with Illustration Conversion 247
Various Embroidering with My Design
Center 249
 Decorative Stitching Around a Pattern 249
 When Embroidering with Batting Sandwiched Between
 Two Layers of Fabric 251
 Decorative Stitching Around a Couching Patterns 252

Chapter 7 Maintenance and
Troubleshooting 255

Care and Maintenance 255
 Restrictions on Oiling 255
 Precautions on Storing the Machine 255
 Cleaning 255
 Needle Calibration for Camera/Projector 257
 Before Lending or Disposing of the Product..... 258
 Confirming the Machine Number/Serial Number 258
Updating Your Machine's Software 258
 Update Procedure Using USB Media 258
 Update Procedure Using Wireless LAN Connection 259
Troubleshooting 260
 Upper Thread Is Too Tight 260
 Tangled Thread on Wrong Side of Fabric 261
 Incorrect Thread Tension 261
 Fabric Is Caught in the Machine and Cannot
 be Removed 262
 If the Thread Becomes Tangled Under the Bobbin
 Winder Seat..... 263
 List of Symptoms 264
Error Messages 269

Chapter 8 Appendix 271

Specifications 271
Stitch Chart 273
INDEX 280



Chapter 1 Getting Ready

Note

- Be sure to install the latest software. Refer to “Updating Your Machine’s Software” on page 258.

Names of Machine Parts

Front View

IMPORTANT

- Do not place any object weighing 1 kg (2.2 lb) or more on the top cover, otherwise the cover may be damaged.
- Do not touch the camera or projector. Otherwise, it will not display properly.

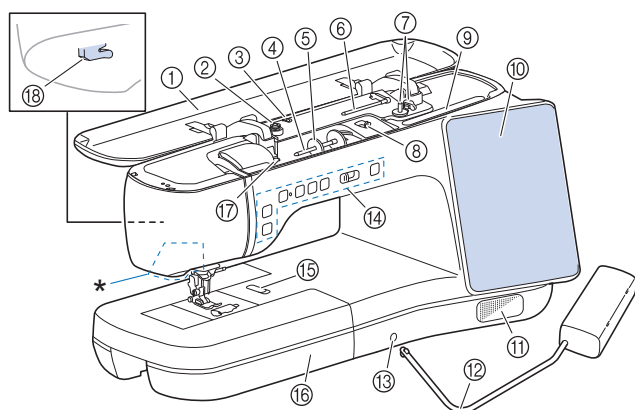

* Camera and projector (built-in)

- ① Top cover
- ② Pretension disk (page 37)
- ③ Thread guide for bobbin winding (page 37)
- ④ Spool pin (page 42)
- ⑤ Spool cap (page 42)
- ⑥ Supplemental spool pin (page 37, page 106)
- ⑦ Bobbin winder (page 37)
- ⑧ Bobbin winding slider (page 37)
- ⑨ Dual purpose stylus tray (page 15)
- ⑩ LCD (liquid crystal display) (page 17)
- ⑪ Speaker
- ⑫ Knee lifter (page 72)
- ⑬ Knee lifter slot (page 72)
- ⑭ Operation buttons and sewing speed controller (page 14)
- ⑮ Needle plate lever (page 255)
- ⑯ Flat bed attachment with accessory compartment (page 15)
- ⑰ Thread guide plate (page 42)
- ⑱ Thread cutter (page 42)

Right-side/Rear View

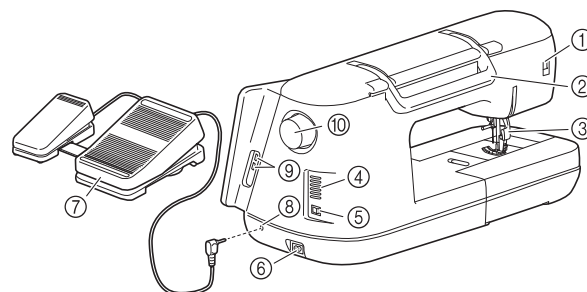

- ① Connector for the presser foot (page 49)
- ② Handle
Carry the machine by its handle when transporting the machine.
- ③ Presser foot lever
Raise and lower the presser foot lever to raise and lower the presser foot. You cannot use the presser foot lever after the presser foot has been raised using  (Presser foot lifter button).
- ④ Air vent
The air vent allows the air surrounding the motor to circulate. Do not cover the air vent while the machine is being used.
- ⑤ Main power switch (page 16)
- ⑥ Power cord receptacle (page 16)
- ⑦ Advanced multi-function foot controller (page 53)
- ⑧ Foot controller jack (page 53)
- ⑨ USB ports (page 17, page 64)
- ⑩ Handwheel
Rotate the handwheel toward you (counterclockwise) to raise and lower the needle.

Needle and Presser Foot Section

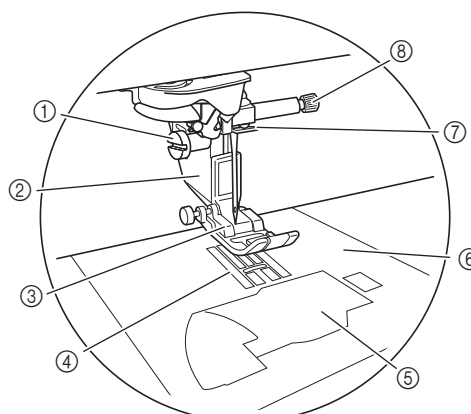

- ① Presser foot holder screw (page 48)
- ② Presser foot holder (page 48)
- ③ Presser foot
The presser foot consistently applies pressure to the fabric as sewing takes place. Attach the appropriate presser foot for the selected stitch.
- ④ Feed dogs
The feed dogs feed the fabric in the sewing direction.
- ⑤ Bobbin cover (page 40, page 83)
- ⑥ Needle plate (page 82, page 255)
- ⑦ Needle bar thread guide (page 42)
- ⑧ Needle clamp screw (page 36)

Embroidery Unit

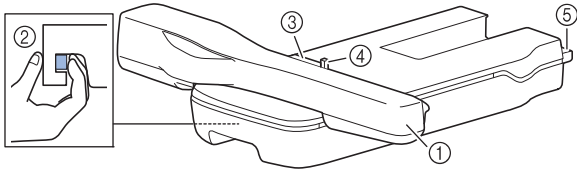

- ① Carriage (page 126)
- ② Release lever (page 127)
- ③ Embroidery frame holder (page 131)
- ④ Frame-securing lever (page 131)
- ⑤ Embroidery unit connection (page 126)

Operation Buttons

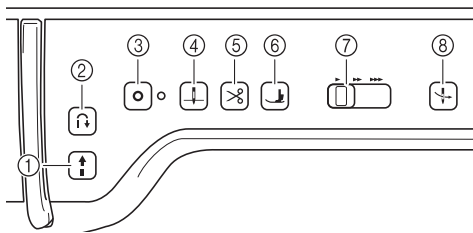

① "Start/Stop" button

Press this button to start or stop sewing. The button changes color according to the machine's operation mode.

Green: The machine is ready or is operating.

Red: The machine is not ready.

② Reverse stitch button

Press this button to sew reverse or reinforcement stitches depending on the selected stitch pattern. (page 56)

③ Reinforcement stitch button

Press this button to sew a single stitch repeatedly and tie-off. For character/decorative stitches, press this button to end with a full stitch instead of at a mid-point. (page 55)
In addition, use this button to sew reinforcement stitches before cutting the thread when changing the bobbin thread in embroidery mode. (page 162)

④ Needle position button

Press this button to raise or lower the needle position. Also with this button, you can lower and raise the needle to sew a single stitch.

⑤ Thread cutter button

Press this button after sewing to automatically trim the excess thread.

⑥ Presser foot lifter button

Press this button to lower the presser foot and apply pressure to the fabric. Press this button again to raise the presser foot.

⑦ Sewing Speed controller

Use this controller to adjust the sewing speed. Move the slide to the left to sew at slower speeds. Move the slide to the right to sew at higher speeds.

⑧ Automatic threading button

Press this button to automatically thread the needle.

Included Accessories

For included accessories of your machine, refer to the additional sheet "Included Accessories".

Using the Accessory Case

Slide the latches on the front of the accessory case outward to open it.

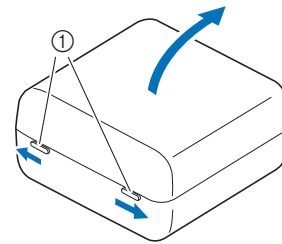

- ① Latches

Memo

- Placing bobbin clips on bobbins helps prevent the thread from unwinding from the bobbin.
- Bobbin clips can be stored inside of the accessory case cover.

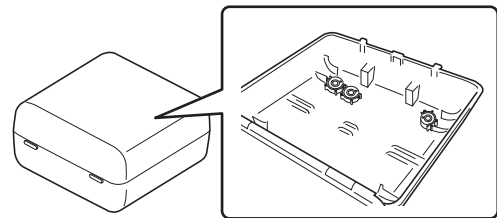
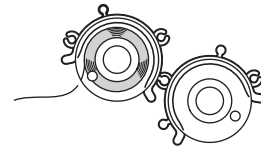

Using the Flat Bed Attachment

Pull the top of the flat bed attachment to open the accessory compartment.

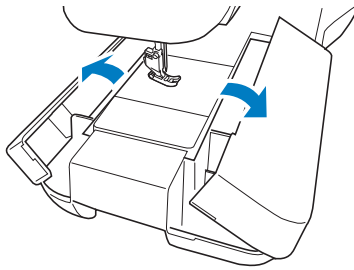

Memo

- Three presser foot storage trays are stored in the included accessory case. For your convenience, a presser foot storage tray can be stored in the accessory compartment of the flat bed attachment.

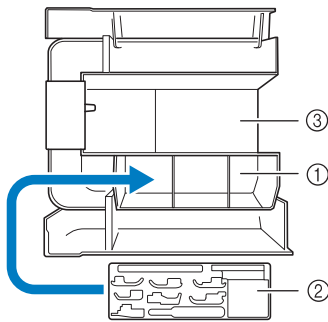

- ① Presser foot storage space of the flat bed attachment
- ② Presser foot storage tray
- ③ Needle plate storage space

Using the Multi-purpose Screwdriver

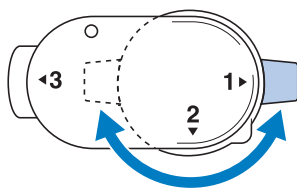

Position "1"	You can install/remove the presser foot holder or needle clamp screw. (page 36, page 48)
Position "3"	You can tighten/loosen the frame adjustment screw. (page 130)

Using the Dual Purpose Stylus

The included dual purpose stylus can be used on both sides. Use the transparent disc to operate the screen and the light to operate the projector. (page 70)

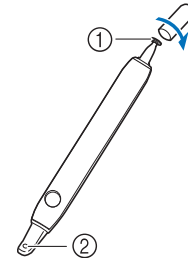

- ① Transparent disc for operating the screen
- ② Light for operating the projector

IMPORTANT

- Touch the LCD screen with the transparent disc on the dual purpose stylus. Using any other part to touch the LCD screen may cause scratches.
- Do not pull on the transparent disc, otherwise damage may result.

Touching the Screen

Touch the LCD screen with the transparent disc on the dual purpose stylus.

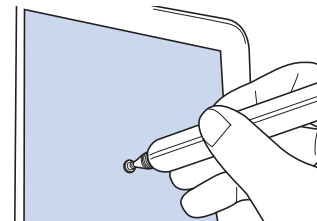

Memo

- Touching the LCD screen with the dual purpose stylus at an excessive angle may prevent the contact position from being correctly detected.
- You can keep the dual purpose stylus with the machine. Open the top cover and place the dual purpose stylus.

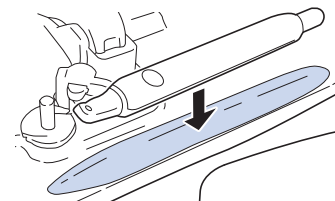

Turning the Machine On/Off

⚠ WARNING

- Use only regular household electricity for the power source. Using other power sources may result in fire, electric shock, or damage to the machine.
- Do not touch the plug with wet hands. Electric shock may result.
- Make sure that the plugs on the power cord are firmly inserted into the electrical outlet and the power cord receptacle on the machine. Otherwise, a fire, electric shock or malfunction may result.
- Turn the main power to OFF and remove the plug in the following circumstances to avoid a fire, electric shock or malfunction from occurring.
 - When you are away from the machine
 - After using the machine
 - When the power fails during use
 - When the machine does not operate correctly due to a bad connection or a disconnection
 - During electrical storms

⚠ CAUTION

- Use the power cord included with this machine. Otherwise, a fire or electric shock may result.
- Do not use extension cords or multi-plug adapters with many other appliances plugged in to them. Fire or electric shock may result.
- When unplugging the machine, always turn the main power to OFF first. Always grasp the plug to remove it from the outlet. Pulling on the cord may damage the cord, or lead to fire or electric shock.
- Do not allow the power cord to be cut, damaged, modified, forcefully bent, pulled, twisted, or bundled. Do not place heavy objects on the cord. Do not subject the cord to heat. These things may damage the cord, or cause fire or electric shock. If the cord or plug is damaged, take the machine to your authorized Brother dealer for repairs before continuing use.
- Do not insert the plug on the power cord into an electrical outlet that is in poor condition. A fire or electric shock may result.
- For U.S.A. only
This appliance has a polarized plug (one blade wider than the other). To reduce the risk of electrical shock, this plug is intended to fit in a polarized outlet only one way. If the plug does not fit fully in the outlet, reverse the plug. If it still does not fit, contact a qualified electrician to install the proper outlet. Do not modify the plug in any way.

- 1 Insert the power supply cord into the power cord receptacle, then insert the plug into a wall outlet.

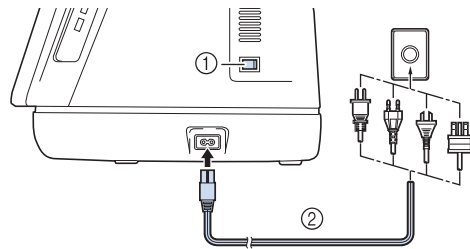

- ① Main power switch
- ② Power supply cord

- 2 Turn the main power switch to “I” to turn on the machine.

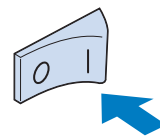

📖 Memo

- When the machine is turned on, the needle and the feed dogs will make sounds when they move; this is not a malfunction.

- 3 When the machine is turned on, the opening movie is played. Touch anywhere on the screen.

- 4 Turn the main power switch to “O” to turn off the machine.

■ Setting Your Machine for the First Time

When you first turn on the machine, set the language and time/date to your language and local time/date.

- 1 Touch and to set your local language, and then touch [OK].

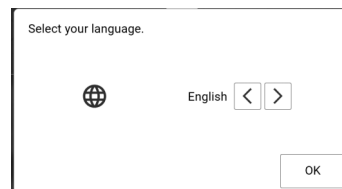

- 2 Touch [OK] to read end-user license agreements (EULA).

- 3 Touch [I Agree] after reading end-user license agreements.

* Read every page. Swipe the screen with your finger to turn the page.

4 The message screen confirming if you want to set time/date appears. Touch [OK].

5 Touch **-** or **+** to set time/date. And then touch [OK].

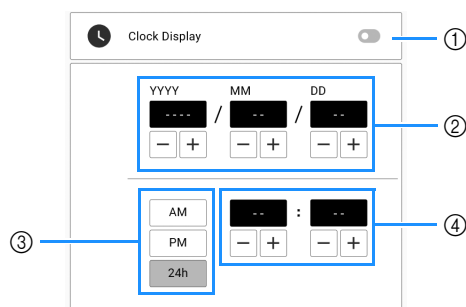

- ① Turn clock display on or off.
- ② Set the year (YYYY), month (MM) and date (DD).
- ③ Select whether 24h or 12h setting to display.
- ④ Set the current time.

Memo

- The time/date you set may be cleared if you do not turn on the machine for an extended period of time.

6 The following message about a wireless LAN connection appears. To set up a connection, touch [OK], and then refer to steps **5** through **8** of “Set Up the Wireless Network Connection” on page 32 to finish setting up a wireless LAN connection.

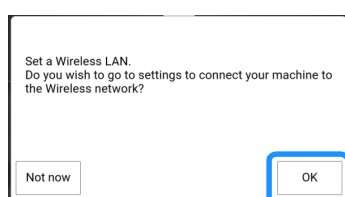

7 The message screen confirming if you want to set the voice guidance appears. To turn on the voice guidance function, touch [OK], and then refer to “Voice Guidance” on page 28.

LCD Screen

Touch the LCD screen or a key with your finger or the included dual purpose stylus to select a machine function. (page 15)

IMPORTANT

- Only touch the screen with your finger or the dual purpose stylus included with the machine. Do not use a mechanical pencil, screwdriver or any other hard or sharp object. In addition, do not press the screen with extreme pressure. Otherwise the screen may be damaged.

Memo

- The screens and icons shown in the document may differ from the actual ones.

Tooltips

Some keys have a tooltip, which is a small descriptive message that appears with a long press of the key.

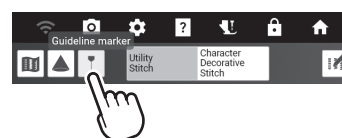

Using a USB Mouse (Commercially Available)

The USB mouse (commercially available) can be connected to the USB port of the machine. The left mouse button can be used to perform operations such as choosing a design and choosing menu keys.

Memo



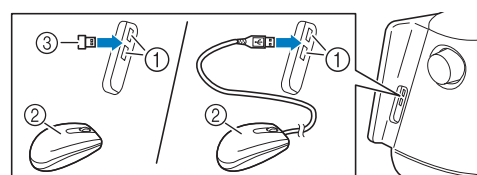



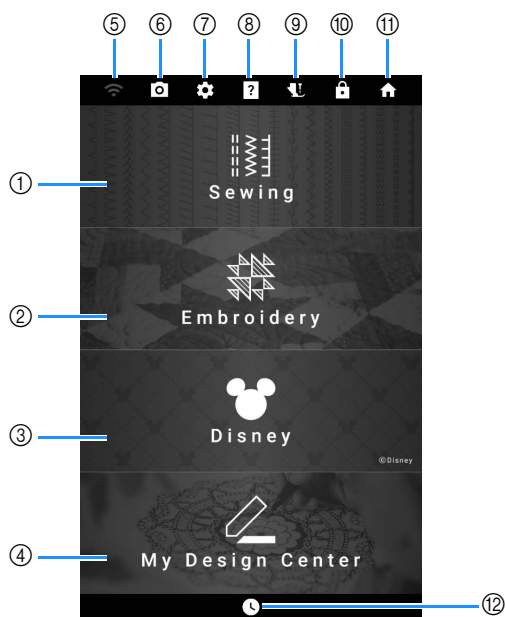

- Use a basic computer mouse to operate the machine functions. Some USB mouse devices may not be compatible with this machine.
- When the mouse is connected, the pointer appears on the screen.
- Tooltips can be shown by moving the mouse over the keys.







- ① USB ports
- ② USB mouse
- ③ Receiver for USB mouse

Home Page Screen



No.	Display	Explanation	Reference
	Name		
①		Select a utility stitch or character/ decorative stitch pattern.	19, 51
	Sewing key		
②		Select an embroidery pattern.	134
	Embroidery key		
③		Touch this key to embroider Disney patterns.	—
	Disney key		
④		Create an original embroidery pattern.	227
	My Design Center key		
⑤		Specify the wireless LAN settings. Also, this key shows the machine's wireless LAN signal strength. If there is a new update file, the key appears as  .	32, 259
	Wireless LAN key		
⑥		Touch this key to check the needle location.	74
	Camera view key		
⑦		Change the machine settings.	22
	Machine settings key		
⑧		See explanations on how to use the machine. Use the QR code that appears in the screen to access instructional videos for the machine.	29
	Machine help key		

No.	Display	Explanation	Reference
	Name		
⑨		Touch this key before changing the needle, the presser foot, etc. This key locks all key and button functions to prevent operation of the machine.	36, 40, 48
	Presser foot/ Needle exchange key		
⑩		Lock the screen. Touch this key again to unlock the screen.	—
	Screen lock key		
⑪		Cancel all operations previously performed and return to the home page screen.	—
	Home page screen key		
⑫		Set the time/date.	16
	Time/Date key		

Sewing Screens

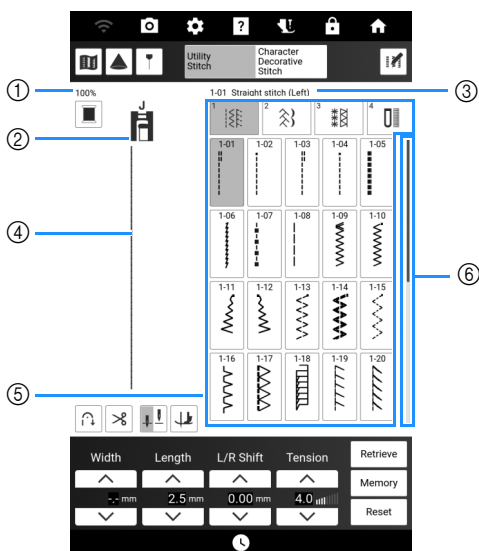

No.	Display	Explanation	Reference
	Name		
①	100%	Shows the approximate ratio of the displayed size of the selected stitch pattern compared to its actual size.	—
	Stitch pattern display size		
②		Shows the recommended presser foot. Attach the presser foot indicated in this display before sewing.	48
	Presser foot display		
③	1-01 Straight stitch (Left)	Shows the name and code number of the selected stitch.	—
	Selected stitch display		
④		Shows a preview of the selected stitch. When shown at 100%, the stitch appears in the screen at nearly its actual size. Touch to display the stitch preview and the camera view together to check how the stitch will be sewn on the actual fabric.	74
	Stitch preview		
⑤		Select the category, and then touch the key of the stitch you want to sew.	51
	Stitch selection screen		
⑥		Slide the scroll bar to move the pages of stitch selection screen.	—
	Scroll bar		







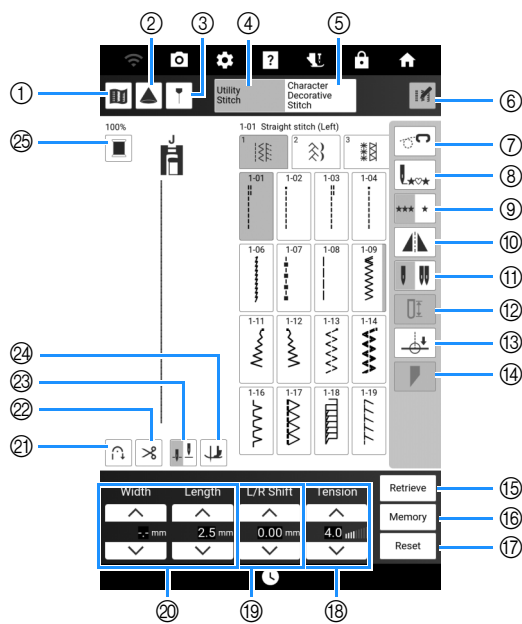



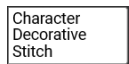





Key Functions (Utility Stitch Screen)













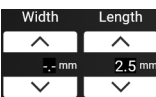



Memo

- Editing function keys are found after touching .
- Some editing functions cannot be used with certain stitch patterns. Only the functions for the displayed keys are available when a stitch pattern is selected.



No.	Display	Explanation	Reference
	Name		
①		Touch this key to display an enlarged image of the selected stitch pattern. Touch to change the thread color in the image. To display the enlarged image, touch . To view any part of the image that extends out of the viewable display area, touch / . / .	—
	Preview key		
②		Touch this key to use projector functions.	70
	Projector key		
③		Touch this key to display or set the guideline marker for the sewing line. The guideline marker makes quilt piecing or aligning stitching on the fabric edge easier.	65
	Guideline marker key		
④	Utility Stitch	Touch this key to select a straight stitch, zigzag stitch, buttonhole, blind hem stitch, or other stitches commonly used in garment construction.	51
	Utility stitch key		

No.	Display	Explanation	Reference
	Name		
⑤		Touch this key to select character or decorative stitch patterns.	51
	Character/Decorative stitch key		
⑥		Touch this key to display editing function keys on the screen.	—
	Edit menu key		
⑦		Touch this key to enter free motion sewing mode. The presser foot is raised to an appropriate height and the feed dogs are lowered for free motion quilting.	111
	Free motion mode key		
⑧		When sewing is stopped, touch this key to return to the beginning of the stitch.	59
	Back to beginning key		
⑨		Touch this key to choose single stitches or continuous stitches.	59
	Single/Repeat sewing key		
⑩		Touch this key to create a mirror image of the selected stitch pattern.	—
	Mirror image key		
⑪		Touch this key to select twin needle sewing mode. The sewing mode changes between single needle mode and twin needle mode each time you touch the key. If the key display is light gray, the selected stitch pattern cannot be sewn in the twin needle mode.	106
	Single needle/twin needle key		
⑫		Touch this key to manually set the buttonhole length when a buttonhole stitch is selected.	89
	Slit length key		
⑬		Touch this key to specify the sewing end point.	75
	End point setting key		
⑭		Touch this key to change the start and end angles of the stitch pattern.	98
	Stitch tapering key		
⑮		Touch this key to retrieve a saved stitch pattern.	63
	Retrieve key		
⑯		Change the stitch pattern settings (stitch width and stitch length, thread tension, etc.), then save them by touching this key.	63
	Manual memory key		
⑰		Touch this key to return the selected stitch pattern saved settings to the default settings.	63
	Reset key		
⑱		Shows the automatic thread tension setting of the currently selected stitch pattern. You can use  and  to change the thread tension settings.	62
	Thread tension key		

No.	Display	Explanation	Reference	
	Name			
⑲		Touch  to shift the stitch pattern to the right or touch  to shift the stitch pattern to the left. This feature is not available for all stitch patterns. Only those applicable will be shifted.	61	
	[L/R Shift] key			
⑳		Shows the zigzag width and stitch length settings of the currently selected stitch pattern. You can use  and  to adjust the zigzag width and stitch length settings.	61	
	Stitch width and stitch length key			
㉑		Touch this key to use the automatic reinforcement stitching (reverse stitching) setting.	56	
	Automatic reinforcement key			
㉒		Touch this key to set the automatic thread cutting function.	58	
	Automatic thread cutting key			
㉓		Touch this key to select the needle stop position to be up or down. You can also check the needle mode setting (single or twin).  Single needle/down position  Single needle/up position  Twin needle/down position  Twin needle/up position	72, 106	
				Needle stop position setting key
				Needle stop position setting key
				Needle stop position setting key
				Needle stop position setting key
㉔		The pivot key appears when the needle position setting key is set to  . Touch this key to select the pivot function. When the pivot function is selected, stopping the machine lowers the needle and slightly raises the presser foot automatically. In addition, when sewing is restarted, the presser foot is automatically lowered. The auto up key appears when the needle position setting key is set to  . Touch the auto up key to raise the presser foot when the machine is stopped.	59, 72	
				Pivot key / Auto Up key
㉕		Touch this key to change the thread color displayed on the screen.	74	
				Thread color change key

■ Key Functions (Character/Decorative Stitch Screen)

Memo

- The key displayed in ⑦ will vary according to the selected stitch pattern.

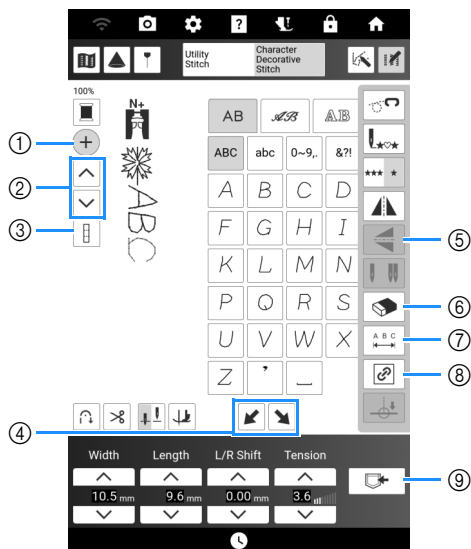

No.	Display	Explanation	Reference
	Name		
①		Touch this key to add a new stitch pattern.	59
	Add stitch pattern key		
②		Touch this key to select the stitch pattern for editing.	60
	Stitch pattern selection key		
③		Touch this key to switch between selecting only the last stitch pattern entered or all combined stitch patterns.	—
④		Touch this key to make step stitch patterns.	104
	Step effect key		
⑤		After selecting the stitch pattern, use this key to create a vertical mirror image of the stitch pattern.	—
⑥		Delete the selected stitch pattern.	59
	Delete key		

No.	Display	Explanation	Reference
	Name		
⑦		After selecting a stitch pattern with , use this key to change the thread density of the stitch pattern. : Low density : High density When the select all on/off key appears as , the thread density of all stitch patterns can be changed.	—
	Thread density key		
⑧		When a stitch pattern is selected with , touch this key to choose from five automatic length settings, without changing the zigzag width or stitch length settings. 	—
	Elongation key		
⑨		Touch this key to change the spacing of character stitch patterns. The setting is applied to all entered characters.	—
	Character spacing key		
⑧		Touch this key to maintain the aspect ratio when enlarging or reducing the stitch pattern.	60
	Maintain aspect ratio key		
⑨		Touch this key to save stitch pattern combinations or stitches with modified/customized settings.	64
	Memory key		

Memo

- For the other keys, refer to “Key Functions (Utility Stitch Screen)” on page 19.



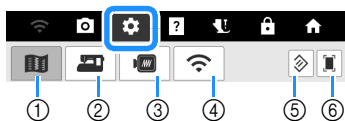

Settings Screen

Touch  to change the default machine settings (language, speaker volume, opening display, etc.).



- ① Display sewing settings
- ② Display general settings
- ③ Display embroidery settings
- ④ Display wireless LAN settings
- ⑤ The settings on the page containing this key will be reverted to their defaults.
- ⑥ An image of the current settings screen can be saved on USB media. Connect the USB media to the USB port of the machine. The image file will be saved in a folder labeled [bPocket].

Memo

- Touch  or  to display the previous or next page.
-  is a switch for turning on or off a function. When the switch appears as , the function is turned off (cannot be used).

■ Sewing Settings

□ Page 1

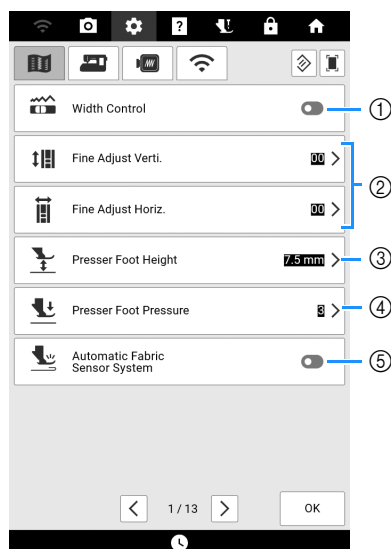

- ① Select whether to use the sewing speed controller to determine the zigzag width. (page 73)
When a straight stitch is selected, the sewing speed controller can be used to change the needle position. (page 81)
- ② Make adjustments to character or decorative stitch patterns. (page 105)
- ③ Adjust the presser foot height. Select the height of the presser foot when the presser foot is raised.
- ④ Adjust the presser foot pressure. The higher the number, the greater the pressure will be. Set the pressure at [3] for normal sewing.
- ⑤ When set to on, the thickness of the fabric is automatically detected by an internal sensor while sewing. This enables the fabric to be fed smoothly. (page 73, page 79)

□ Page 2

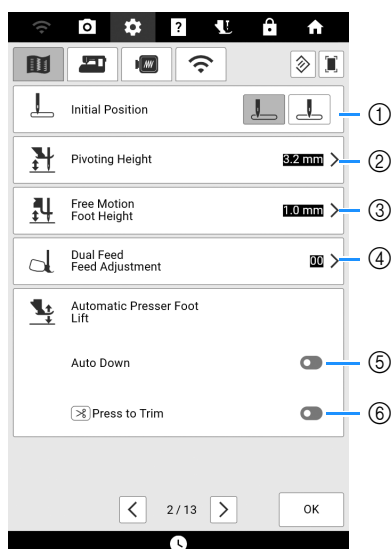



- ① Select whether [1-01 Straight stitch (Left)] or [1-03 Straight stitch (Middle)] is the utility stitch that is automatically selected when the machine is turned on.
- ② Change the height of the presser foot when sewing is stopped when the pivot setting is selected. (page 72)

- ③ Change the height of the presser foot when the machine is set to free motion sewing mode. (page 111)
- ④ Adjust the amount of fabric feeding of the compact dual feed foot. (page 50)
- ⑤ Pressing the “Start/Stop” button or depressing the foot controller automatically lowers the presser foot (if it is raised) before starting sewing.
- ⑥ Pressing  (Thread cutter button) automatically lowers the presser foot before cutting the thread. The presser foot will be raised after the thread is cut.

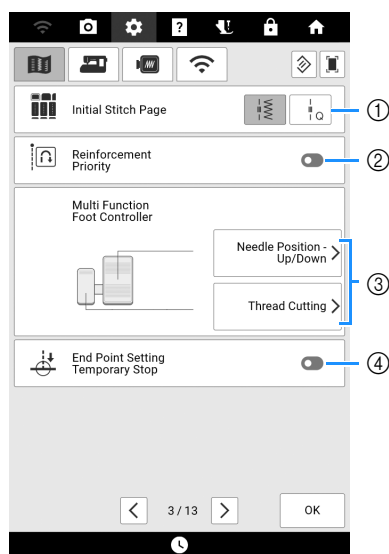
□ Page 3



- ① Select whether utility stitches () or quilting stitches () are displayed first in the stitch selection screen.
- ② When set to on, reinforcement stitches are sewn at the beginning and/or end of sewing for a reinforcement stitch pattern, even when  (Reverse stitch button) is pressed. (page 56)
- ③ Select the functions to be performed by the multi-function foot controller. (page 53)
- ④ If this setting is set to on with [End Point Setting] in the stitch edit menu, the machine will temporarily stop so the end point sticker can be peeled off. (page 75)

■ General Settings

□ Page 4

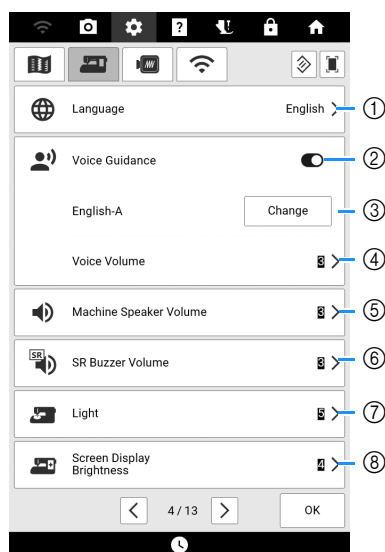

- ① Change the display language.
- ② Turn on/off the voice guidance function. (page 28)
- ③ Change the language and voice of the voice guidance. (page 28)
- ④ Adjust the voice guidance volume.
- ⑤ Change the speaker volume.
- ⑥ Adjust the stitch regulator warnings volume. (page 118)
- ⑦ Change the brightness of the needle area and work area lights.
- ⑧ Adjust the brightness of the screen.

□ Page 5

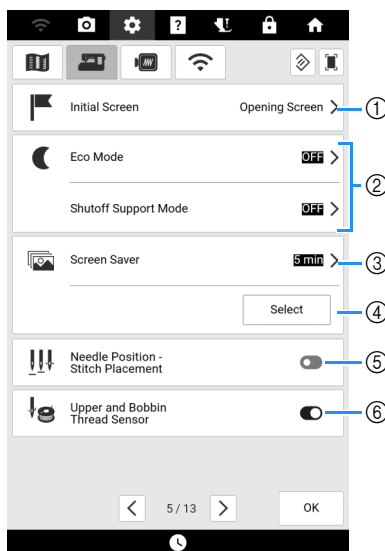

- ① Select whether to display the opening screen video when the machine is turned on.
- ② Select to save the machine power by setting the [Eco Mode] or the [Shutoff Support Mode]. (page 27)
- ③ Select the length of time until the screen saver appears.

- ④ Change the image of the screen saver. (page 27)
- ⑤ Select the operation of the [Needle Position - Stitch Placement] to on or off. (page 75)
- ⑥ Turn both the upper and bobbin thread sensor on or off. If it is turned off, the machine can be used without thread.

□ Page 6

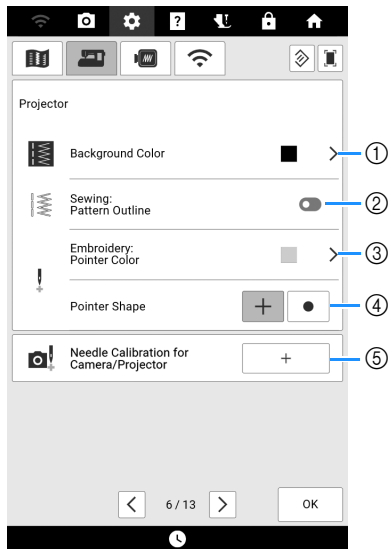

- ① Select which background color will display when using projector function. (page 70)
- ② Select whether to display outline of the stitch pattern. (page 70)
- ③ Select the color of the pointer. (page 139)
- ④ Select a cross shape or a point as the shape for the pointer. (page 139)
- ⑤ Gauge the needle drop point to adjust the accuracy of the camera display area and of the projection area. (page 257)

□ Page 7

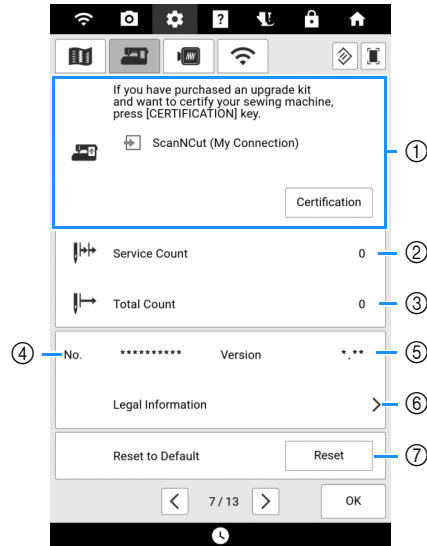

- ① Use to certify your machine when you use [My Connection] function with Brother cutting machine (sold separately). For details, visit the following webpage and refer to the "My Connection" Operation Manual.



<https://s.brother/cmdae/>

- ② Display the service count which is a reminder to take your machine in for regular servicing. (Contact your authorized Brother dealer for details.)
- ③ Display the total number of stitches sewn on this machine.
- ④ The [No.] is the internal machine number for the machine.
- ⑤ Display the program version.
- ⑥ Display legal information.
- ⑦ Erase all saved data, customized settings and network information in the machine. (page 258)

■ Embroidery Settings

□ Page 8

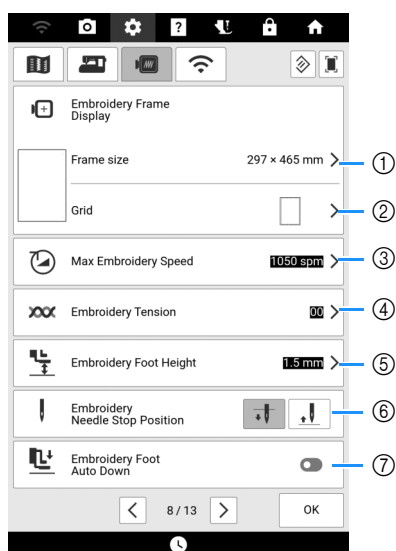

- ① Select the embroidery frame to be used. (page 227)
- ② Change the center point marker or grid lines.
- ③ Adjust the maximum embroidery speed setting.
- ④ Adjust the upper thread tension for embroidering. (page 165)
- ⑤ Select the height of the embroidery foot during embroidering.
- ⑥ Select the needle stop position for embroidering.
- ⑦ When set to on, and the presser foot is raised, pressing the “Start/Stop” button will automatically lower the presser foot when starting embroidery.

□ Page 9

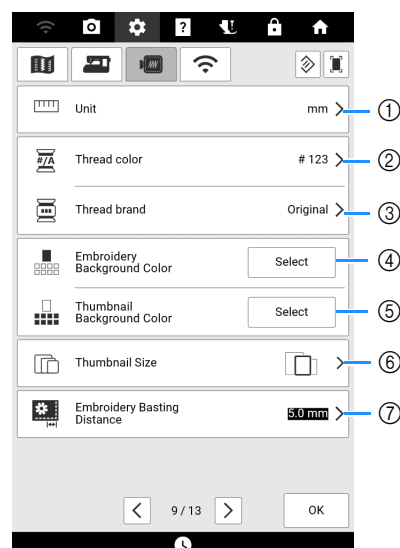

- ① Change the display units (mm/inch).
- ② Change the thread color display on the embroidery screen. Select [Name of Color] or [#123] (thread number).
- ③ Select the thread brand of the thread color display. [Original] is set as a default and will retain the brand thread used by the designer who created the pattern. The thread brand setting is reflected the next time a pattern is imported. (page 140)
- ④ Change the color of the background for the embroidery display area.
- ⑤ Change the color of the background for the thumbnail area.
- ⑥ Touch to specify the size of pattern thumbnails.
- ⑦ Adjust the distance between the pattern and the basting stitching. (page 173)

□ Page 10

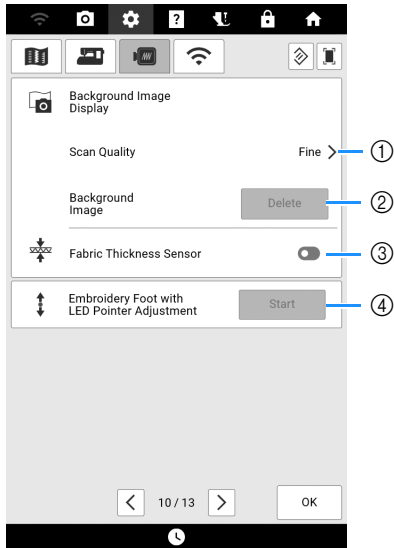

- ① Select the quality for displaying the fabric in the screen. (page 157)
- ② Erase the scanned image.
- ③ When set to on, the built-in camera adjusts the display of the background image according to the thickness of the fabric. (page 158)
- ④ Adjust the position and brightness of the embroidery foot “W+” with LED pointer (sold separately).

■ Wireless LAN Settings

□ Page 11

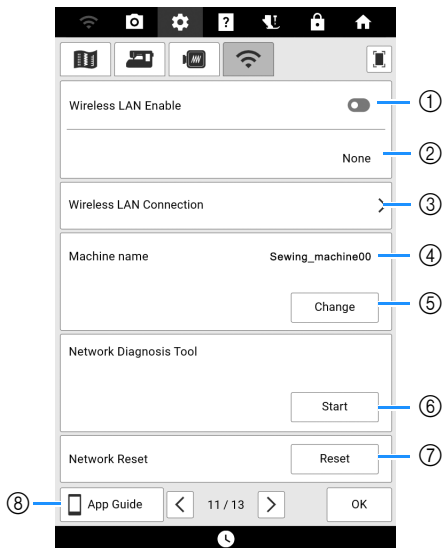

- ① Enable/disable the wireless LAN function. (page 32)
- ② Display the connected SSID.
- ③ Set the machine to connect wireless LAN function. (page 32)
- ④ Display the machine name of wireless LAN function.
- ⑤ Change the machine name of wireless LAN function.
- ⑥ Check the wireless LAN status.
- ⑦ Reset network settings.
- ⑧ Displays the introduction to the applications.

□ Page 12

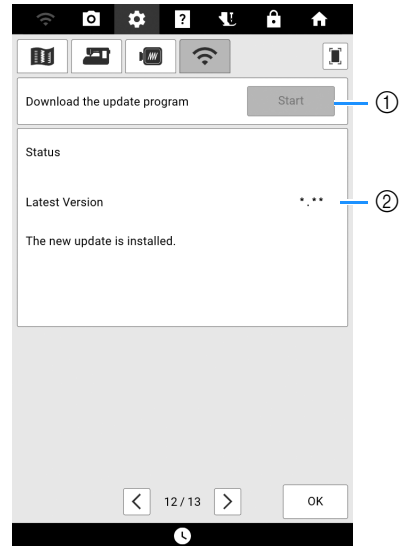

- ① If there is a new software version, download the update file. (page 259)
- ② Display program information. (page 259)

□ Page 13

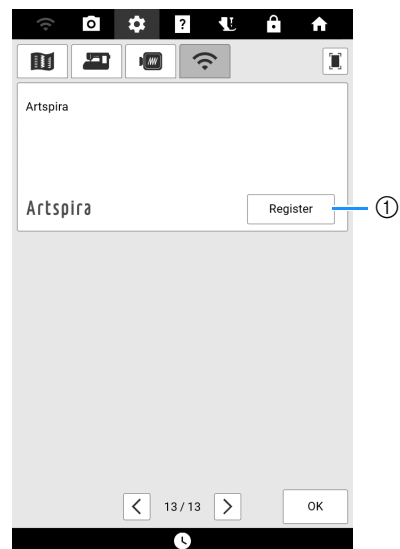

- ① Register the Artspira app. (page 225)

■ Selecting the [Eco Mode] or [Shutoff Support Mode]

You can save the machine power by setting the [Eco Mode] and the [Shutoff Support Mode]. If you leave the machine without using for a specified period of time, the machine enters into one of these modes. Touch  to display [Eco Mode] and [Shutoff Support Mode]. (page 23)

[Eco Mode];

Machine will enter a sleep mode. Touch the screen or press the “Start/Stop” button to continue operating.

[Shutoff Support Mode];

Machine will enter the lower power mode after set period of time. Turn machine off and then back on to restart operating.

Memo

- If you turn off the machine while the machine is in the [Eco Mode] or the [Shutoff Support Mode], wait for about 5 seconds before turning on the machine again.
- For details on condition of the [Eco Mode] and [Shutoff Support Mode], refer to “Specifications” on page 271.

■ Changing the Screen Saver Image

Instead of the default image, you can select your own personal images for the screen saver of your machine.

For details on compatible image files, refer to “Specifications” on page 271.

- 1 Touch  to display [Screen Saver] of the settings screen.
- 2 Touch [Select], and then touch [Customize].



- 3 Connect the USB media that contains your personal image to the USB port of the machine.
- 4 Touch [Change] to select the first image.

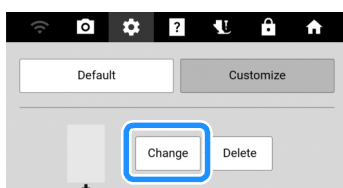

- * Touch [Delete] to delete the selected image.

5 Touch the device that is connected.

- * If two USB media are connected to the machine, check the USB media names that are displayed, and then touch the name of the USB media that you wish to use.



6 Touch a file name to select image. Touch [Set] and then touch [OK].

Memo

- Touch [Default] to select default images for the screen saver.



■ Voice Guidance

The guidance messages can be read out loud.

- 1 **Connect the machine to your wireless network to change voice option. (page 32)**
- 2 **Touch  to display [Voice Guidance] of the settings screen and set the function to on.**

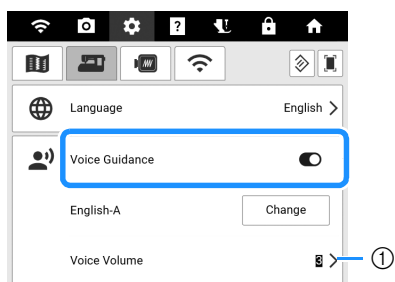

① Adjust the voice guidance volume.

- 3 **Touch [Change] and then select the language and voice of the voice guidance.**

* Touch  to hear sample audio for the selected setting.

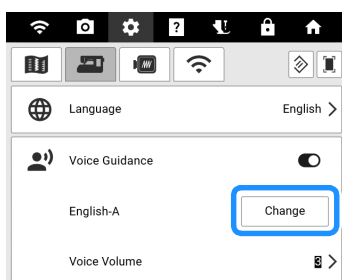



- 4 **Touch [Next].**

→ A message appears, indicating that the machine is checking for the voice guidance data. If the voice guidance data must be downloaded, downloading begins.

- 5 **After a message appears, indicating that voice guidance has been turned on, touch [OK].**

→ The guidance messages will now be read out loud.

Memo

- Touch  in the message that was read out loud in order to hear the message again. To stop read out loud, touch .

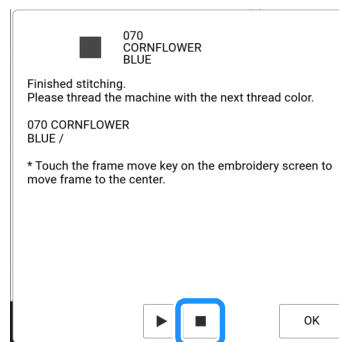

Machine Help Screen

Touch  to open the machine help screen. Functions are available from the screen shown below.

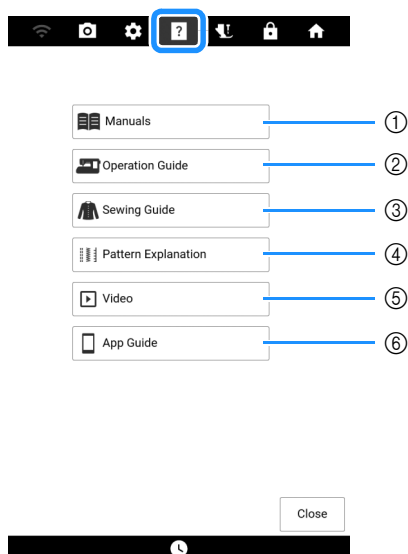

- ① Manuals for this machine. (page 30)
- ② Explanation for how to use the machine. (page 29)
- ③ Procedures for sewing utility stitches. (page 29)
- ④ Explanation of the stitch selected. (page 29)
- ⑤ Use the QR code that appears in the screen to access instructional videos for the machine. The specifications shown in the video may display different details than the actual product.
- ⑥ Displays the introduction to the applications. Touch the key of the app whose information you want to display.

Using the Operation Guide Function

Touch [Operation Guide] to open the screen shown below. Categories are displayed at the top of the screen. Touch a key to see more information about that category.

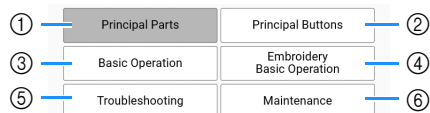

- ① Information about the main parts of the machine and their functions
- ② Information about the operation buttons
- ③ Information about threading the machine, changing presser feet, etc.
- ④ Information about attaching the embroidery unit, preparing fabric for embroidering, etc.
- ⑤ Information about troubleshooting
- ⑥ Information about cleaning the machine, etc.

Using the Sewing Guide Function

Use this function when you are not sure which stitch to use for your application, or to get advice about sewing particular stitches.

- 1 Enter Utility Stitch category from the home page.
- 2 Touch .
- 3 Touch [Sewing Guide].
- 4 Touch the key of the category whose sewing instructions you wish to view.

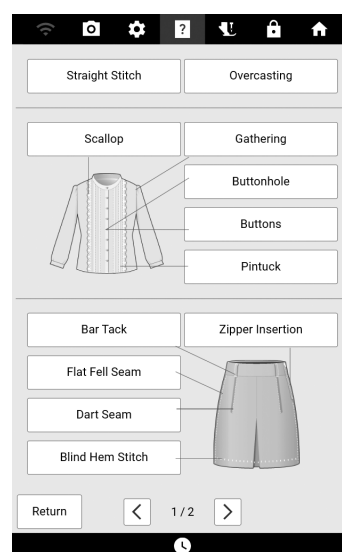



- 5 Read the explanations and select the appropriate stitch.

→ The screen displays directions for sewing the selected stitch. Follow the directions to sew the stitch.

Using the Stitch Pattern Explanation Function

If you want to know more about the uses of a stitch pattern, select the stitch pattern and touch  and then [Pattern Explanation] to see an explanation of the stitch selection.

Example: Displaying information about 

- 1 Touch .
- 2 Touch .
- 3 Touch [Pattern Explanation].

■ Viewing the Operation Manual (PDF File) on the Machine

- 1 Touch [?].
- 2 Touch [Manuals].
- 3 Select the document to be viewed.
- 4 Read the Operation Manual. Swipe the screen with your finger to turn the page.

* To change the direction that the pages are turned, touch >> (7).

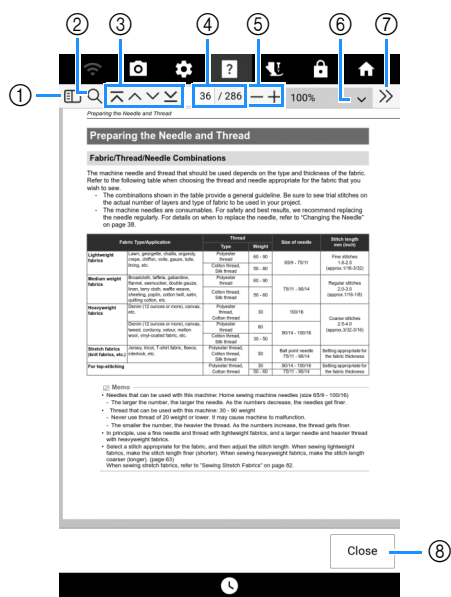

- 1 Touch to display a thumbnail of each page.
- 2 Touch to use the search function.
- 3 Touch to display the first page/previous page/next page/last page.
- 4 Shows the current page/total number of pages. To display a specific page, enter the page number in the box.
- 5 Touch to display the page enlarged/reduced.
- 6 Select a page magnification ratio.
- 7 Touch to display other settings.
- 8 Touch to close the screen.

■ Instructional Videos

The instructional videos are available online and can be viewed on any mobile device or computer.



<https://s.brother/cvdae/>

You can also access them using the QR code that appears in the screen. (page 29)

Wireless Network Connection Functions

Available Operations

The following useful operations will be available if the machine is connected to a wireless network.

■ For Updating

Directly download the update file to the machine. (page 259)

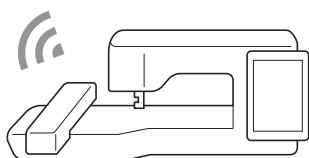

■ Mobile Application

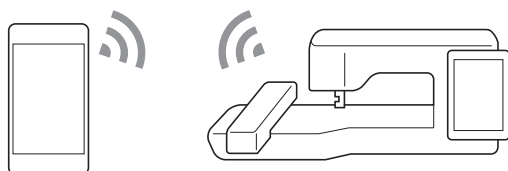

Name	Function	Reference
My Stitch Monitor	Conveniently check the operating status of the machine from your mobile device.	225
My Design Snap	Transfer an image from the mobile device to the machine to create a design to embroider.	225
Artspira	Transfer content published on the app to the embroidery machine and enjoy creating original works using the functions on the app.	225

■ Windows application

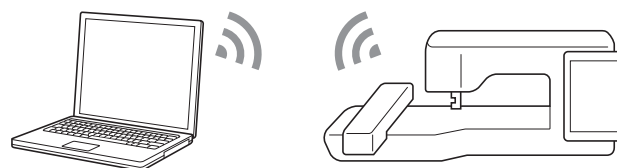

Name	Function	Reference
Design Database Transfer	Wirelessly transfer an embroidery pattern from your computer to the machine. The application can be downloaded to your computer from the following URL. https://s.brother/cadkb/ Settings must be specified in Design Database Transfer. For more information, refer to the manual for Design Database Transfer.	—
PE-DESIGN (Sold separately)	Wirelessly transfer to the machine an embroidery pattern edited with embroidery editing software (PE-DESIGN version 11 or later) on a computer. Also, transfer to PE-DESIGN an embroidery pattern edited on the machine. Settings must be specified in PE-DESIGN. For more information, refer to the manual for PE-DESIGN.	—

Set Up the Wireless Network Connection

The machine can be connected to your wireless network. For the requirements for a wireless network connection, refer to “Specifications” on page 271.

1 Touch .



2 Set [Wireless LAN Enable] to on.

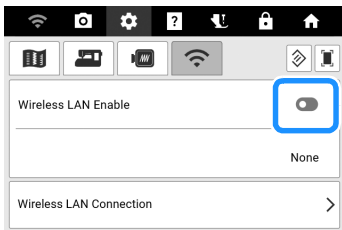

→ The machine will begin to emit the wireless network signal.

3 In order to connect your machine to a wireless network, the security information (SSID and password) for your home network will be required. The password may also be called a network key, security key or encryption key. First, find your security information and note it.

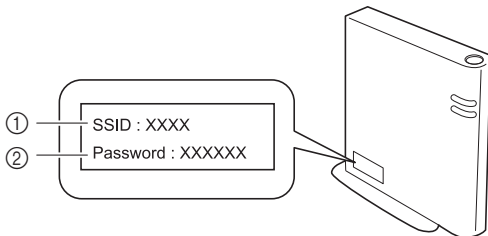

- ① SSID
- ② Password (network key)

Memo

- The wireless network connection cannot be set up if you do not have the security information.
- How to find the security information
 - Check the manual provided with your home network.
 - The default SSID may be the manufacturer's name or the model name.
 - If you cannot find the security information, contact the manufacturer of the router, your network administrator or your Internet provider.
 - Some SSIDs and password (network key) are case (upper case and lower case) sensitive. Please properly record your information.

4 Touch > beside [Wireless LAN Connection].

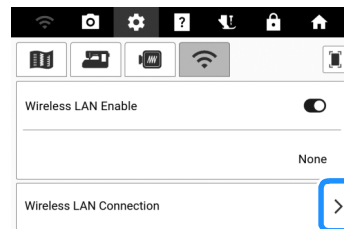

→ A list of available SSIDs appears.

5 Select the SSID that was noted in step 3.



→ The screen for entering the password (network key) appears.

Memo

- If the wireless access point/router is not broadcasting the SSID, the SSID will not automatically be detected. In this case, touch [Add network], and then type in the necessary information.
- If the machine had already been connected to the home network, touch [Saved networks]. Select the saved SSID and then touch [CONNECT].

6 Enter the password (network key) that was noted, and then touch [CONNECT].

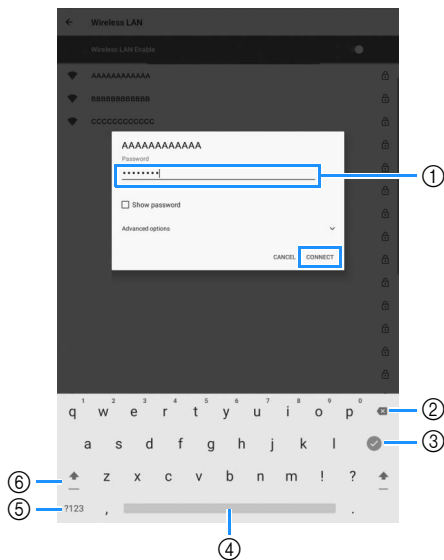

- ① Text input area
- ② Backspace key (Deletes the character at the cursor's position.)
- ③ Touch to hide the keyboard. Touch the text input area to display the keyboard again.
- ④ Space key
- ⑤ Letter/number selection key
- ⑥ Uppercase/lowercase selection key

7 After confirming that [Connected] is displayed under the SSID, touch ←.



Note

- If the password was entered incorrectly, touch the SSID again, and then enter the correct password. If the screen for entering the password does not appear, touch its SSID then touch  in the appeared screen to show the screen for entering password then enter the correct password.
- If an incorrect SSID was selected, touch the correct SSID. If an incorrect SSID was manually entered, touch [Add network], and then type in the necessary information.

Memo

- Touch the connected SSID to display its detailed information. Touch  in the upper-right corner and display [Advanced options] to specify the IP address and proxy settings.

8 Touch [OK] to exit the setup.

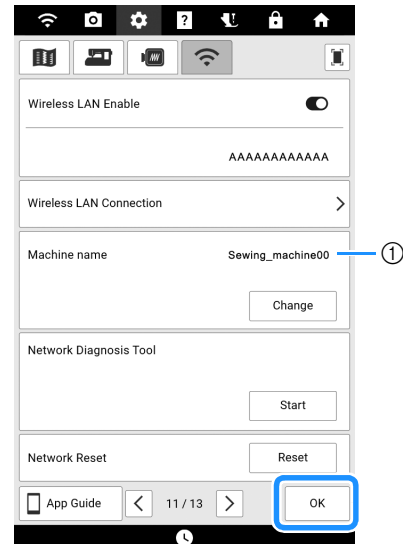

- ① The name in the [Machine name] field will be used with the apps described in "Available Operations" on page 31.

Memo

- While connected, the signal strength is indicated by the icon in the upper-left corner of the display.
- Once a wireless network connection has been set up, a wireless network connection will be established each time the machine is turned on. However, [Wireless LAN Enable] in the Wireless LAN settings screen must remain set to on.

Preparing the Needle and Thread

Fabric/Thread/Needle Combinations

The machine needle and thread that should be used depends on the type and thickness of the fabric. Refer to the following table when choosing the thread and needle appropriate for the fabric that you wish to sew.

- The combinations shown in the table provide a general guideline. Be sure to sew trial stitches on the actual number of layers and type of fabric to be used in your project.
- The machine needles are consumables. For safety and best results, we recommend replacing the needle regularly. For details on when to replace the needle, refer to “Changing the Needle” on page 36.

Fabric Type/Application		Thread		Size of needle	Stitch length mm (inch)
		Type	Weight		
Lightweight fabrics	Lawn, georgette, challis, organdy, crepe, chiffon, voile, gauze, tulle, lining, etc.	Polyester thread	60 - 90	65/9 - 75/11	Fine stitches 1.8-2.5 (approx.1/16-3/32)
		Cotton thread, Silk thread	50 - 80		
Medium weight fabrics	Broadcloth, taffeta, gabardine, flannel, seersucker, double gauze, linen, terry cloth, waffle weave, sheeting, poplin, cotton twill, satin, quilting cotton, etc.	Polyester thread	60 - 90	75/11 - 90/14	Regular stitches 2.0-3.0 (approx.1/16-1/8)
		Cotton thread, Silk thread	50 - 60		
Heavyweight fabrics	Denim (12 ounces or more), canvas, etc.	Polyester thread, Cotton thread	30	100/16	Coarse stitches 2.5-4.0 (approx.3/32-3/16)
		Denim (12 ounces or more), canvas, tweed, corduroy, velour, melton wool, vinyl-coated fabric, etc.	Polyester thread	60	
	Cotton thread, Silk thread		30 - 50		
Stretch fabrics (knit fabrics, etc.)	Jersey, tricot, T-shirt fabric, fleece, interlock, etc.	Polyester thread, Cotton thread, Silk thread	50	Ball point needle 75/11 - 90/14	Setting appropriate for the fabric thickness
For top-stitching		Polyester thread, Cotton thread	30	90/14 - 100/16	Setting appropriate for the fabric thickness
			50 - 60	75/11 - 90/14	

Memo

- Needles that can be used with this machine: Home sewing machine needles (size 65/9 - 100/16)
 - The larger the number, the larger the needle. As the numbers decrease, the needles get finer.
- Thread that can be used with this machine: 30 - 90 weight
 - Never use thread of 20 weight or lower. It may cause machine to malfunction.
 - The smaller the number, the heavier the thread. As the numbers increase, the thread gets finer.
- In principle, use a fine needle and thread with lightweight fabrics, and a larger needle and heavier thread with heavyweight fabrics.
- Select a stitch appropriate for the fabric, and then adjust the stitch length. When sewing lightweight fabrics, make the stitch length finer (shorter). When sewing heavyweight fabrics, make the stitch length coarser (longer). (page 61)
When sewing stretch fabrics, refer to “Sewing Stretch Fabrics” on page 79.

■ Transparent Nylon thread

Use a home sewing machine topstitching needle, regardless of the fabric or thread.

■ Needles and Threads When Sewing Character/Decorative Stitch Patterns

When sewing lightweight, medium weight or stretch fabrics, use a ball point needle (gold colored) 90/14. When sewing heavyweight fabrics, use a home sewing machine needle 90/14. In addition, #50 to #60 thread should be used.

Embroidery Needles

Use a 75/11 home sewing machine needle for embroidery. When embroidering patterns with short stitches, such as small letters, we recommend using a ball point needle for embroidery.

CAUTION

- The appropriate fabric, thread and needle combinations are shown in the preceding table. If the combination of the fabric, thread and needle is not correct, particularly when sewing heavy fabrics (such as denim) with thin needles (such as 65/9 to 75/11), the needle may break and cause injury. In addition, the stitching may be uneven or puckered or there may be skipped stitches.

How to Use the Spool Cap and Spool Net

Check the spool to be used, and prepare the necessary parts.

Spool Cap

Three spool cap sizes are available, allowing you to choose a spool cap that best fits the size of spool being used.



When using the spool as shown in the illustration, use the thread spool insert (mini king thread spool). Make sure that the thread spool insert is firmly inserted. After installing it, pull out some thread, and check that the thread unwinds without getting caught.

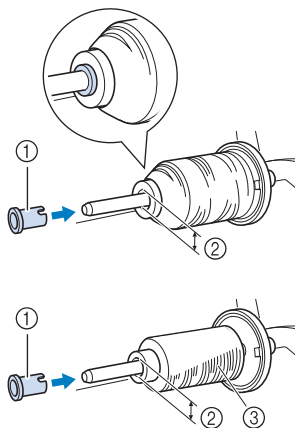

- Thread spool insert (mini king thread spool)
- Hole diameter 8.0 mm to 10.5 mm (approx. 5/16 inch to 13/32 inch)
- Spool (cross-wound thread)

Spool Net

When using thread that winds off quickly, such as transparent nylon thread or metallic thread, place the spool net over the spool before placing the spool of thread onto the spool pin.

If the spool net is too long, fold it to fit the size of the spool.

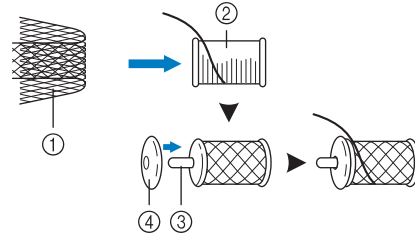

- Spool net
 - Thread spool
 - Spool pin
 - Spool cap
- * When threading the spool with the spool net on, make sure that 5-6cm (approx. 2 - 2-1/2 inches) of thread is pulled out.
 - * It may be necessary to adjust the thread tension when using the spool net.

Changing the Needle

⚠ CAUTION

- When replacing the needle, be sure to touch  on the screen to lock all keys and buttons, otherwise injuries may occur if the “Start/Stop” button or any other button is pressed and the machine starts.
- Use only home sewing machine needles made for home use. Other needles may break and may cause injury.
- Never sew with a bent needle. This may cause injury.

💡 Note

- To check the needle correctly, place the flat side of the needle on a flat surface. Check the needle from the top and the sides. Throw away any bent needles.

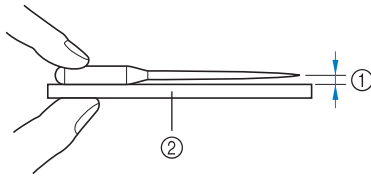

- ① Parallel space
- ② Level surface (bobbin cover, glass, etc.)

- The machine needles are consumables. Replace the needle in cases such as those described below.
 - If an unusual sound is produced when the needle enters the fabric. (The tip of the needle may be broken or dull.)
 - If stitches are skipped. (The needle may be bent.)
 - Generally, after completing one project, such as a piece of clothing.

1 Press  (Needle position button) to raise the needle.

2 Touch  to lock all keys and buttons.

- * If the message [OK to automatically lower the presser foot?] appears on the LCD screen, touch [OK] to continue.

💡 Note

- Before replacing the needle, cover the hole in the needle plate with fabric or paper to prevent the needle from falling into the machine.

3 Remove the presser foot. (page 48)

4 Use the screwdriver to turn the needle clamp screw toward the front of the machine and loosen the screw. Remove the needle.

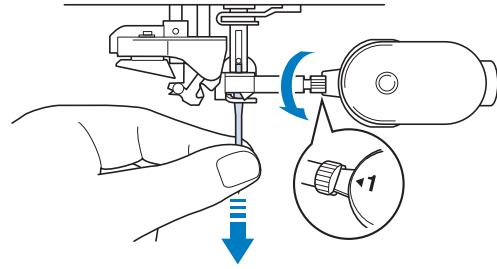

5 With the flat side of the needle facing the back, insert the new needle until it touches the needle stopper. Use a screwdriver to securely tighten the needle clamp screw.

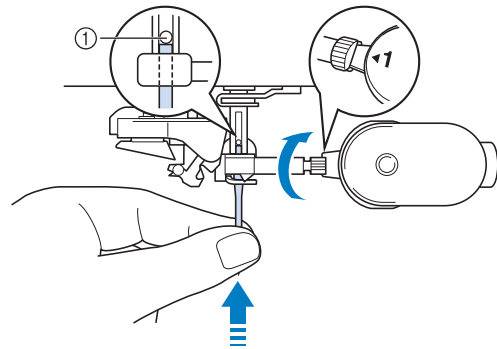

- ① Needle stopper

⚠ CAUTION

- Be sure to insert the needle until it touches the needle stopper and securely tighten the needle clamp screw with the screwdriver, otherwise the needle may break and cause injury.

6 Attach the presser foot. (page 48)

7 Touch  to unlock all keys and buttons.

Winding/Installing the Bobbin

Winding the Bobbin

IMPORTANT

- Use the plastic bobbins that came with this machine or bobbins of the same type: 11.5 mm (approx. 7/16 inch) plastic Class 15 (A style) bobbins, which are available from your Brother dealer.

■ Using the Supplemental Spool Pin

While the main spool pin is being used for sewing, you can wind a bobbin by using the supplemental spool pin.

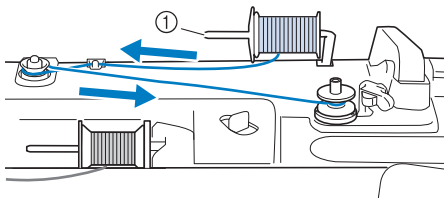

① Supplemental spool pin

- Turn the main power to ON and open the top cover.
- Align the groove in the bobbin with the spring on the bobbin winder shaft, and set the bobbin on the shaft.

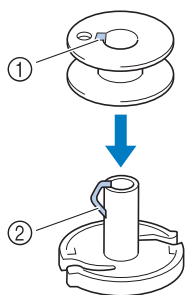

① Groove in the bobbin
② Spring on the shaft

- Place the spool of thread for the bobbin and the spool cap onto the supplemental spool pin.

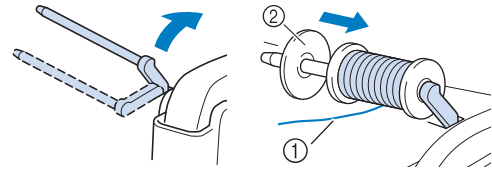

① The thread unwinds to the front from the bottom.
② Spool cap

IMPORTANT

- If the spool or the spool cap is not installed correctly, the thread may become tangled around the spool pin and the machine may be damaged.
- Choose a spool cap that best fits the size of spool being used. For more information regarding the choice of spool caps for your thread choice, refer to "How to Use the Spool Cap and Spool Net" on page 35.

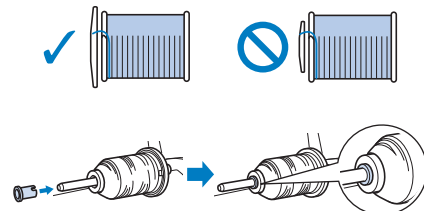

- With your right hand, hold the thread near the thread spool. With your left hand, hold the end of the thread, and use both hands to pass the thread through the thread guide.

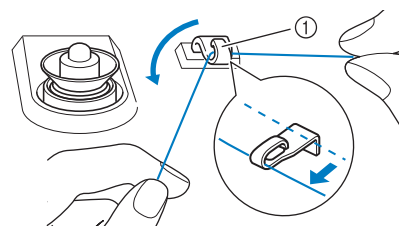

① Thread guide

- Pass the thread around the pretension disk making sure that the thread is under the pretension disk.

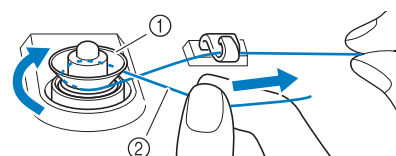

① Pretension disk
② Check to make sure thread is securely set between pretension disks.

6 Wind the thread clockwise around the bobbin 5 or 6 times, pass the thread through the guide slit in the bobbin winder seat, and then pull the thread to cut it.

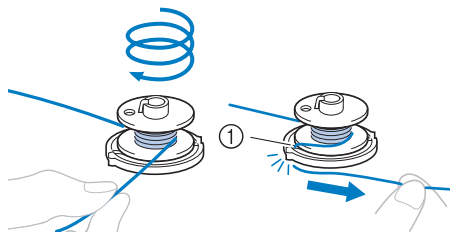

① Guide slit in bobbin winder seat (with built-in cutter)

Note

- Be sure to wind the thread clockwise around the bobbin, otherwise the thread may become wrapped around the bobbin winder shaft.

CAUTION

- Be sure to cut the thread as described. If the bobbin is wound without cutting the thread using the cutter built into the guide slit in the bobbin winder seat, the thread may become tangled in the bobbin or the needle may break and cause injury when the bobbin thread starts to run out.

7 Set the bobbin winding switch to the left, until it clicks into place.

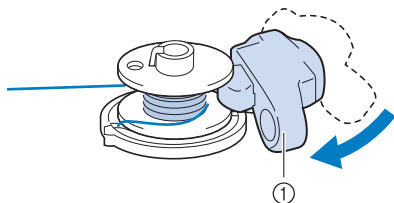

① Bobbin winding switch

Memo

- Use the bobbin winding slider to adjust the amount of thread wound onto the bobbin to one of five levels.

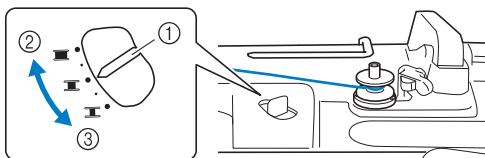

① Bobbin winding slider
② More
③ Less

8 Touch [Start].

- * If the bobbin thread is wound incorrectly, touch [Stop]. Cut the thread, slide the bobbin winding switch to the right, and then remove the bobbin.

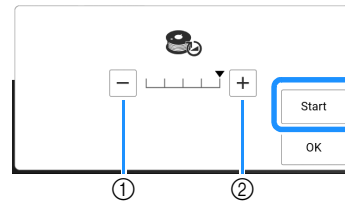

- ① Touch to decrease the winding speed.
- ② Touch to increase the winding speed.

→ Bobbin winding starts. [Start] changes to [Stop] while the bobbin is winding. The bobbin stops rotating when bobbin winding is completed. The bobbin winding switch will automatically return to its original position.

Memo

- Touch [OK] to minimize the bobbin winding window. Touch  (in top right of the LCD screen) to display the bobbin winding window again.



- The sound of winding the bobbin with stiff thread, such as nylon thread for quilting, may be different from the one produced when winding normal thread; however, this is not a sign of a malfunction.

IMPORTANT

- For stretchable thread such as transparent nylon thread, start winding the bobbin at low speed, then stop when it is about half full. Otherwise, the bobbin may not be wound neatly or may be damaged.

9 After bobbin winding is finished, cut the thread and remove the bobbin.

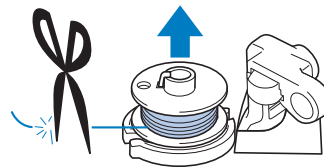

IMPORTANT

- When removing the bobbin, do not pull on the bobbin winder seat. Doing so could loosen or remove the bobbin winder seat, and could result in damage to the machine.

■ Using the Spool Pin

You can use the main spool pin to wind the bobbin before sewing. You cannot use this spool pin to wind the bobbin while sewing.

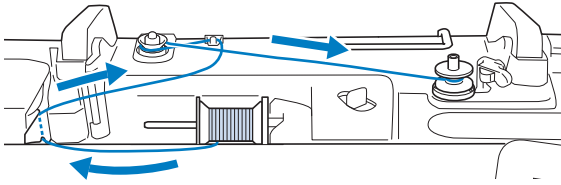

- 1** Turn the main power to ON and open the top cover.
- 2** Align the groove in the bobbin with the spring on the bobbin winder shaft, and set the bobbin on the shaft.

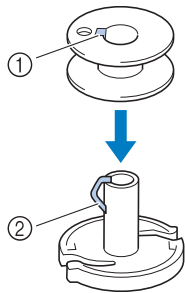

- ① Groove in the bobbin
- ② Spring on the shaft

- 3** Pivot the spool pin so that it angles upward. Set the thread spool on the spool pin so that the thread unwinds from the front of the spool.

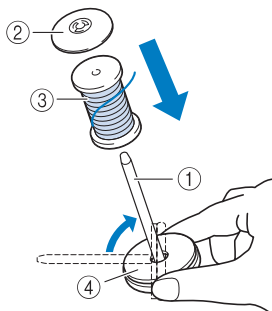

- ① Spool pin
- ② Spool cap
- ③ Thread spool
- ④ Spool felt

- 4** Push the spool cap onto the spool pin as far as possible, then return the spool pin to its original position.

- 5** While holding the thread with both hands, pull the thread up from under the thread guide plate.

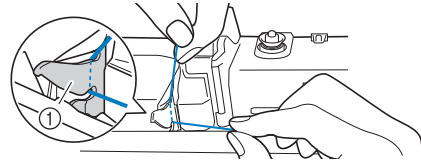

- ① Thread guide plate

- 6** Pass the thread through the thread guide.

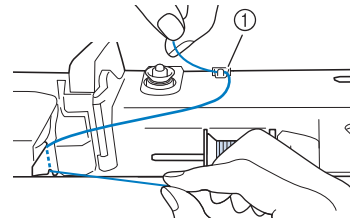

- ① Thread guide

- 7** Pass the thread around the pretension disk making sure that the thread is under the pretension disk.

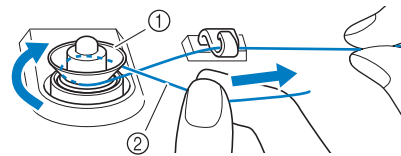

- ① Pretension disk
- ② Check to make sure thread is securely set between pretension disks.

- 8** Follow steps 6 through 9 of “Using the Supplemental Spool Pin” on page 37.

■ Using the Spool Stand (Winding the Bobbin)

Pass the thread from the spool through the thread guide on the telescopic thread guide, and then wind the bobbin according to steps 4 through 9 of “Using the Supplemental Spool Pin” on page 37. For details on spool stand, refer to “Using the Spool Stand” on page 45.

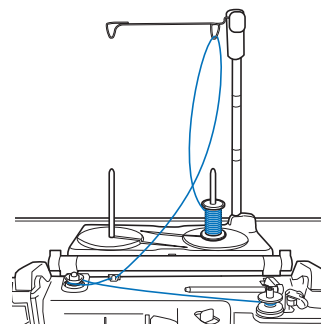

Setting the Bobbin

⚠ CAUTION

- Use a bobbin thread that has been correctly wound. Otherwise, the thread tension may be incorrect and the needle may break, causing injuries.



- Before inserting or changing the bobbin, be sure to touch  in the LCD to lock all keys and buttons, otherwise injuries may occur if the “Start/Stop” button or any other button is pressed and the machine starts sewing.

1 Touch to lock all keys and buttons and raise the presser foot.

- * If the message [OK to automatically lower the presser foot?] appears on the LCD screen, touch [OK] to continue.

2 Slide the bobbin cover latch to the right.

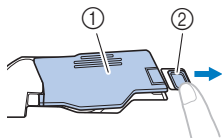

- ① Bobbin cover
- ② Latch

3 Remove the bobbin cover.

4 Hold the bobbin with your right hand and hold the end of the thread with your left hand.

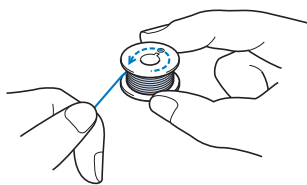

5 Set the bobbin in the bobbin case so that the thread unwinds to the left.

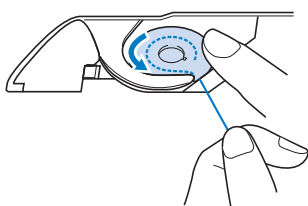

6 Lightly hold down the bobbin with your right hand, and then guide the end of the thread around the tab of the needle plate with your left hand.

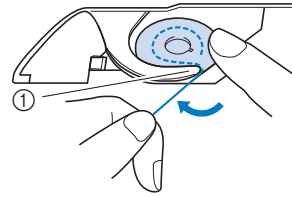

- ① Tab

Note

- Be sure to hold down the bobbin with your finger and unwind the bobbin thread correctly. Otherwise, the thread may break or the thread tension will be incorrect.

7 While lightly holding down the bobbin with your right hand, guide the thread through the slit in the needle plate and lightly pull it with your left hand.

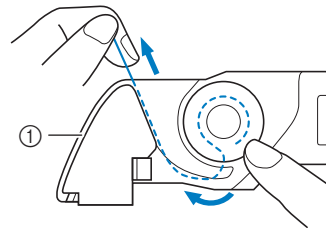

- ① Slit

Memo

- By pulling the thread as shown in step 7, the thread will enter the tension spring of the bobbin case to apply the appropriate tension to the bobbin thread during sewing.

8 While lightly holding down the bobbin with your right hand, continue guiding the thread through the slit with your left hand. Then, cut the thread with the cutter.

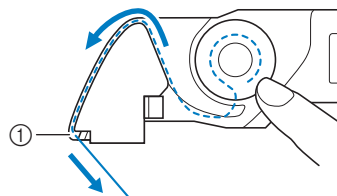

- ① Cutter

- 9** Insert the tab in the lower-left corner of the bobbin cover (1), and then lightly press down on the right side to close the cover (2).



- 10** Touch  to unlock all keys and buttons.

 **Memo**

- You can begin sewing without pulling up the bobbin thread. If you wish to pull up the bobbin thread before starting to sew, pull up the thread according to the procedure of "Pulling Up the Bobbin Thread" on page 41.

Pulling Up the Bobbin Thread

There may be some sewing applications where you want to pull up the bobbin thread; for example, when making gathers, darts, or doing free motion quilting (including stitch regulator sewing) or embroidery.

 **Memo**

- You can pull up the bobbin thread after threading the upper thread ("Upper Threading" on page 42).

- 1** Follow steps **1** through **4** of "Setting the Bobbin" on page 40 for installing the bobbin into the bobbin case.

- 2** Guide the bobbin thread through the groove, following the arrow in the illustration.

- * Do not cut the thread with the cutter.
- * Do not replace the bobbin cover.

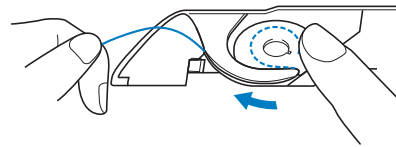

- 3** Touch  to unlock all keys and buttons.

- 4** While holding the upper thread, press  (Needle position button) to lower the needle.

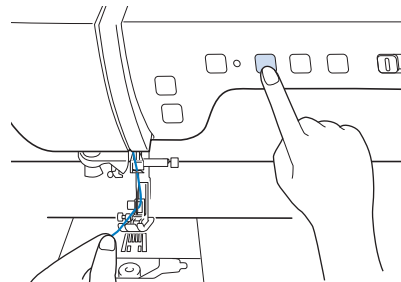

- 5** Press  (Needle position button) to raise the needle.

- 6** Gently pull the upper thread. A loop of the bobbin thread will come out of the hole in the needle plate.

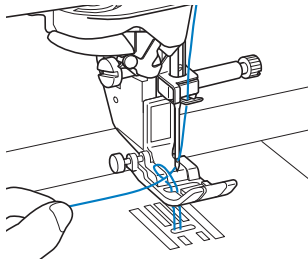

- 7** Pull up the bobbin thread, pass it under the presser foot and pull it about 10 cm (approx. 4 inches) toward the back of the machine, making it even with the upper thread.

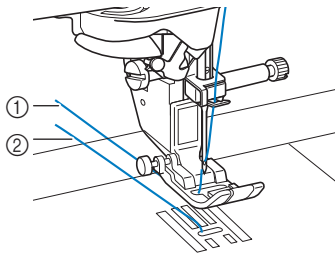

- ① Upper thread
② Bobbin thread

- 8** Replace the bobbin cover.

Upper Threading

Upper Threading

⚠ CAUTION

- Be sure to thread the machine properly. Improper threading can cause the thread to tangle and break the needle, leading to injury.

IMPORTANT

- Never use a thread weight of 20 or lower. It may cause the machine to malfunction. Use the needle and the thread in the correct combination. For details, refer to “Fabric/Thread/Needle Combinations” on page 34.
- When using 65/9 needle, manually thread the needle. If the automatic needle threading function is used, the unit may be damaged.

📖 Memo

- The automatic threading function can be used with home sewing machine needle sizes 75/11 through 100/16.
- When threads such as transparent nylon monofilament or specialty threads are used, it is not recommended to use the needle threader.
- The automatic threading function cannot be used with the twin needle.

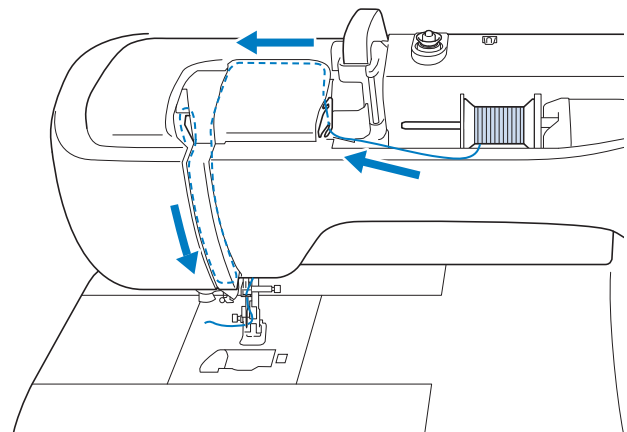

- 1** Turn the main power to ON.

- 2** Press  (Presser foot lifter button) to raise the presser foot.

→ The upper thread shutter opens so the machine can be threaded.

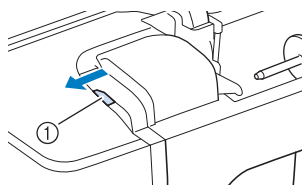

① Upper thread shutter

- 3** Press  (Needle position button) to raise the needle.

IMPORTANT

- Be sure to raise the needle before using the automatic needle threader. Otherwise, the needle may not thread correctly and the needle threader may be damaged.

- 4** Pivot the spool pin so that it angles upward. Set the thread spool on the spool pin so that the thread unwinds from the front of the spool.

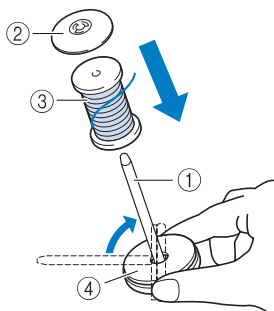

① Spool pin
② Spool cap
③ Thread spool
④ Spool felt

- 5** Push the spool cap onto the spool pin as far as possible, then return the spool pin to its original position.

CAUTION

- If the spool or the spool cap is not installed correctly, the thread may become tangled around the spool pin, possibly causing the needle to break, resulting in injuries.
- Choose a spool cap that best fits the size of spool being used. For more information regarding the choice of spool caps for your thread choice, refer to "How to Use the Spool Cap and Spool Net" on page 35.

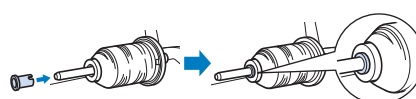

- 6** While holding the thread with both hands, pull the thread up from under the thread guide plate.

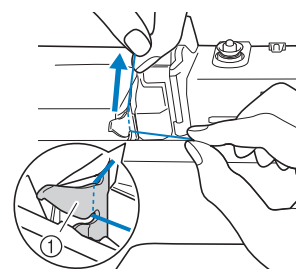

① Thread guide plate

- 7** While holding the thread in your right hand, pass the thread through the thread guide in the direction indicated.

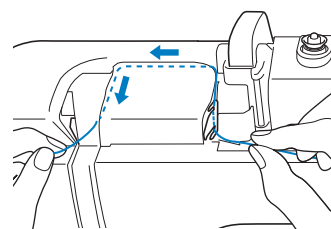

8 Guide the thread down, up, then down through the groove, as shown in the illustration.

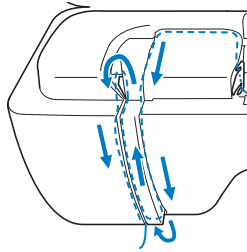

Memo

- Look in the upper groove area to check if the thread catches on the thread take-up lever visible inside the upper groove area.

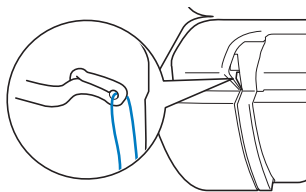

9 Pass the thread through the needle bar thread guide (marked “6”) by holding the thread with both hands and guiding it as shown in the illustration.

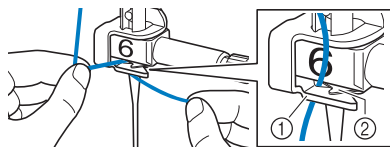

- ① Needle bar thread guide
- ② Tab

10 Pass the thread through the thread guide disks (marked “7”). Make sure that the thread passes through the groove in the thread guide.

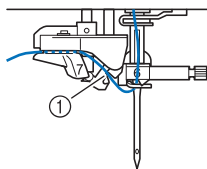

- ① Groove in thread guide

11 Press  (Presser foot lifter button) to lower presser foot.

12 Pull the thread up through the thread cutter to cut the thread, as shown in the illustration.

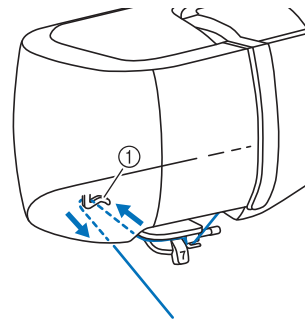

- ① Thread cutter

Note

- When using thread that quickly winds off the spool, such as metallic thread, it may be difficult to thread the needle if the thread is cut. Therefore, instead of using the thread cutter, pull out about 8 cm (approx. 3 inches) of thread after passing it through the thread guide disks (marked “7”).

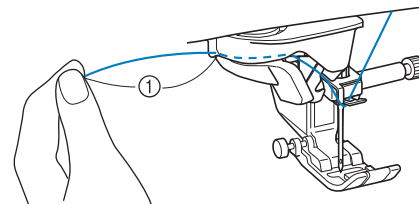

- ① 8 cm (approx. 3 inches) or more

13 Press  (Automatic threading button) to have the machine automatically thread the needle.

14 Carefully pull the end of the thread that was passed through the eye of the needle.

- * If a loop was formed when the thread passed through the eye of the needle, carefully pull the loop of thread through the eye to the back of the needle.

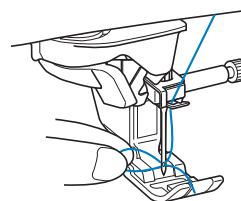

- 15** Raise the presser foot and pull out about 10 cm (approx. 4 inches) of the thread, and then pass it under the presser foot toward the rear of the machine.

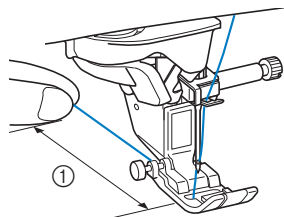

- ① About 10 cm (approx. 4 inches)

Memo

- If the needle could not be threaded or the thread was not passed through the needle bar thread guides, perform the procedure again starting from step **3**.

Note

- When using a needle or thread that cannot be used with a needle threader, manually pass the thread through the eye of the needle from the front.

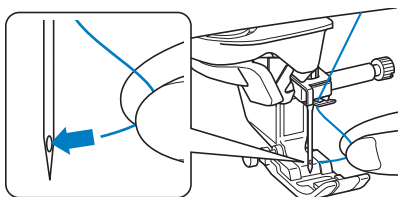

Using the Spool Stand

The included spool stand is useful when using thread spools with a large diameter (cross-wound thread).

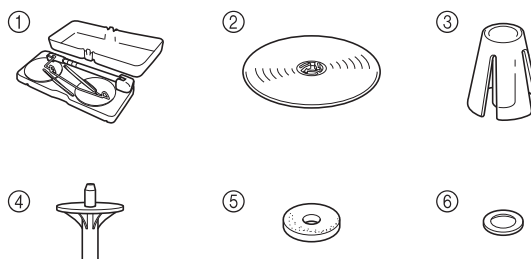

- ① Spool stand
 - ② Spool cap (XL) × 2
 - ③ Spool holder × 2
 - ④ Spool cap base × 2
 - ⑤ Spool felt × 2
 - ⑥ Ring × 4
- * No.2 to No.6 are included in a plastic bag.

■ Assembling the Spool Stand

- 1** Hold in the tabs on the spool stand and remove the lid.

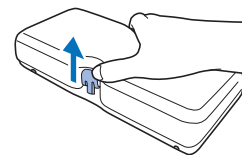

- 2** Fully extend the telescopic thread guide shaft until the two internal stoppers snap into place.
Raise the spool pins.

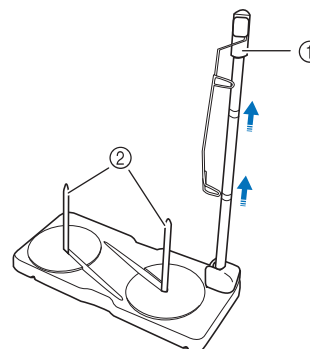

- ① Telescopic thread guide shaft
- ② Spool pins

3 Turn the thread guide counterclockwise.

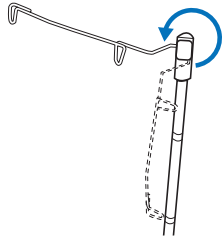

4 Open the upper cover of the machine, and then place the spool stand on the upper cover as shown in the illustration.

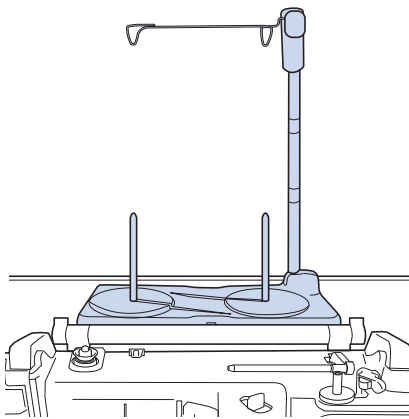

IMPORTANT

- Do not place any object weighing 1 kg (2.2 lb) or more on the top cover. Otherwise the cover may be damaged. The weight of the spool stand with its lid removed is about 280 g (0.6 lb).
- Do not close the upper cover while the spool stand is installed.
- Do not push or pull the telescopic thread guide or spool pins with extreme force, otherwise damage may result.
- Do not place any object other than spools of thread on the spool support.
- Do not try to wind thread on the bobbin while sewing using the spool stand.

Note

- Make sure that the spool stand is firmly secured. Otherwise, the spool stand may fall during sewing.

About the Thread Spool and Spool Cap

Be sure to use a spool cap (①) that is slightly larger than the spool. If the spool cap that is used is smaller or much larger than the spool, the thread may catch and sewing performance may suffer.

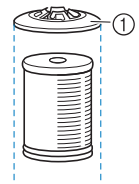

When using thread on a thin spool, place the included spool felt (①) on the spool pin, place the thread spool on the spool pin so that the center of the spool is aligned with the hole at the center of the spool felt, and then insert the spool cap onto the spool pin.



When using a cone spool that is taller than the spool pin, use the spool holder (①). When using cone shaped thread spool with other than cotton thread, it is not necessary to use spool caps.

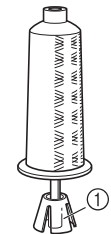

When using fluffy thread such as cotton thread, place a spool cap (①) on the spool cap base (②), as shown in the illustration. Depending on the size of spool or the amount of thread remaining, choose the appropriate sized spool cap. Spool cap (small) cannot be used with the spool cap base.

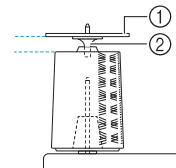

■ Thread the Machine Using the Spool Stand

- 1 Attach the spool stand to the machine. (page 45)
- 2 Place the spool of thread on the spool pin so that the thread feeds off the spool clockwise. Firmly insert the spool cap onto the spool pin.

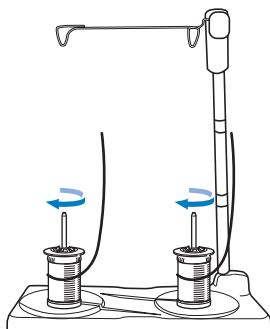

⚠ CAUTION

- Make sure that the spools do not touch each other, otherwise the thread will not feed off smoothly, the needle may break and cause injury. In addition, make sure that the spools do not touch the telescopic thread guide at the center.

💡 Note

- When using 2 spools of thread, make sure that both spools are feeding in the same direction.
- Make sure that the thread is not caught under the spool.

- 3 Pull the thread off the spool. Pass the thread from the back to the front through the thread guides at the top.

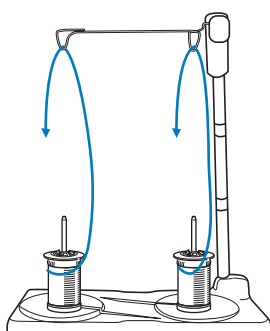

💡 Note

- Guide the thread so that it does not become entangled with the other thread.
- After feeding the thread as instructed, wind any excess thread back onto the spool, otherwise the excess thread will become tangled.
- When using thread that quickly feeds off the spool, such as metallic thread, use the enclosed ring to prevent the thread from becoming entangled. Threading sequence: Pull the thread from the spool, place the thread through the ring from the bottom up (①), into the thread guide (②) and through the ring from the top down (③). When using the ring, do not use the spool cap base.

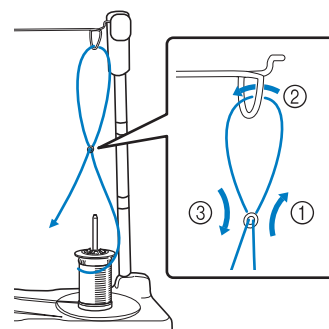

- 4 Pass the thread through the machine's thread guide from the right to the left.

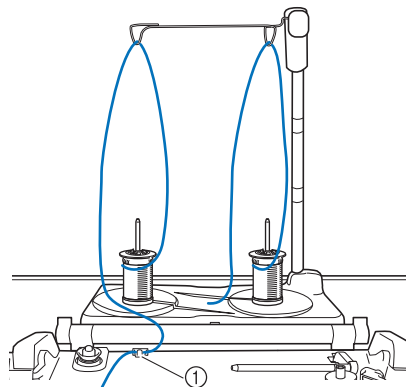

① Thread guide

- 5 Thread the machine according to steps 6 through 15 of "Upper Threading" on page 42.

Changing the Presser Foot



⚠ CAUTION

- When replacing the presser foot, be sure to touch  on the screen to lock all keys and buttons, otherwise injuries may occur if the “Start/Stop” button or any other button is pressed and the machine starts.
- Always use the correct presser foot for the selected stitch pattern. If the wrong presser foot is used, the needle may strike the presser foot and break, and may cause injury.
- Make sure that the presser foot is installed in the correct direction, otherwise the needle may strike the presser foot, breaking the needle and causing injuries.

IMPORTANT

- Use presser feet made for this machine.

Replacing the Presser Foot

- 1 Press  (Needle position button) to raise the needle.
- 2 Touch  to lock all keys and buttons.
 - * If the message [OK to automatically lower the presser foot?] appears on the LCD screen, touch [OK] to continue.
- 3 Raise the presser foot lever manually.
- 4 Press the black button on the presser foot holder and remove the presser foot.

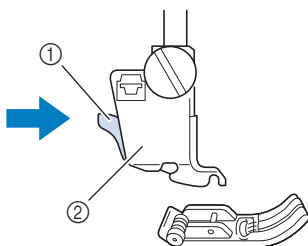

- ① Black button
- ② Presser foot holder

- 5 Place the new presser foot under the holder, aligning the foot pin with the notch in the holder. Lower the presser foot lever manually so that the presser foot pin snaps into the notch in the holder.

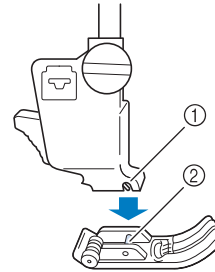

- ① Notch
- ② Pin

- 6 Raise the presser foot lever to check that the presser foot is securely attached.
- 7 Touch  to unlock all keys and buttons.

Attaching the Presser Foot with the Included Adapter

Some presser feet require using the included adapter and screw (small), for example, the free motion echo quilting foot “E” and so on.



- 1 Remove the presser foot. (page 48)
- 2 Loosen the presser foot holder screw to remove the presser foot holder.

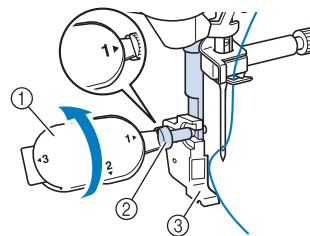

- ① Multi-purpose screwdriver
- ② Presser foot holder screw
- ③ Presser foot holder

- 3 Remove the presser foot holder screw completely from the presser foot shaft.

- 4** Set the adapter on the presser foot bar, aligning the flat side of the adapter opening with the flat side of the presser foot bar. Align the screw holes in the adapter and presser foot bar, and then securely tighten the presser foot holder screw with the screwdriver.

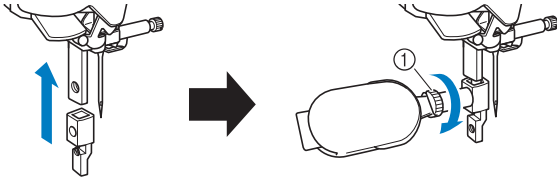

① Presser foot holder screw

Memo

- When attaching the free motion echo quilting foot “E”, refer to “Echo Quilting” on page 113, then go to step 4.

- 5** Turn the included screw (small) 2 or 3 times with your hand.

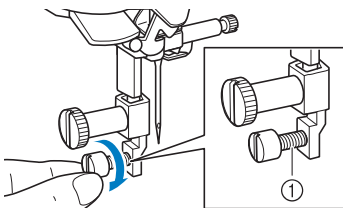

① Screw (small)

- 6** Attach the presser foot, referring to the manual for the presser foot. Tighten the screw (small) with the included screwdriver (large).

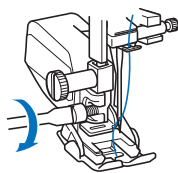

CAUTION

- Use the included screwdriver (large) to tighten the screw securely. If the screw is loose, the needle may strike the presser foot and cause injury.

Using the Compact Dual Feed Foot

The compact dual feed foot enables you to have best fabric control when sewing difficult fabrics that slip easily, such as quilted fabrics or fabrics that tend to stick to the bottom of a presser foot, such as vinyl, leather or synthetic leather.

Note

- When sewing with the compact dual feed foot, sew at medium to low speeds.

Memo

- When the compact dual feed foot is connected to the machine, only stitch patterns that allow sewing with the compact dual feed foot can be selected.
- When sewing fabric that easily sticks together, a more attractive finish can be achieved by basting the beginning of sewing.

■ Attaching the Compact Dual Feed Foot

- 1** Touch . Remove the presser foot. (page 48)
- 2** Loosen the screw of the presser foot holder to remove the presser foot holder.

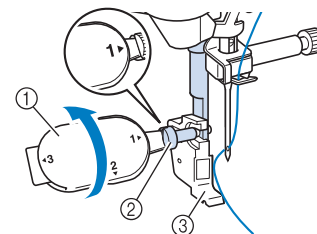

- ① Multi-purpose screwdriver
- ② Presser foot holder screw
- ③ Presser foot holder

- 3** Position the compact dual feed foot to the presser foot bar by aligning the notch of the compact dual feed foot to the screw.

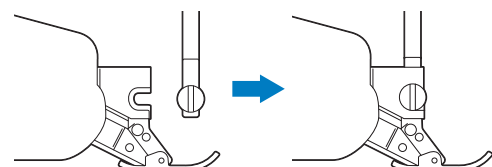

- 4** Hold the compact dual feed foot in place with your right hand, then using the included multi-purpose screwdriver, securely tighten the screw.

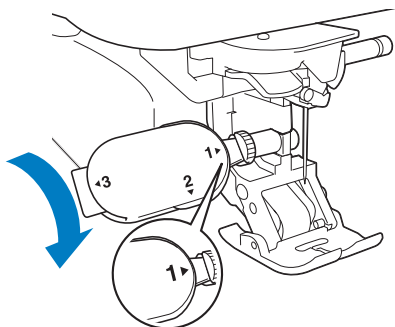

⚠ CAUTION

- Use the included screwdriver to firmly tighten the screw. If the screw is loose, the needle may strike the presser foot and possibly cause injury.

- 5** Plug the connector of the compact dual feed foot into the jack on the back of your machine.

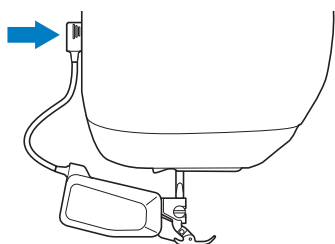

- 6** Touch  to unlock all keys and buttons.
- 7** Place the fabric under the compact dual feed foot with the needle at the starting point of the stitching.
- 8** Be sure that the feed position lever is pushed down and the compact dual feed foot is ready to sew.

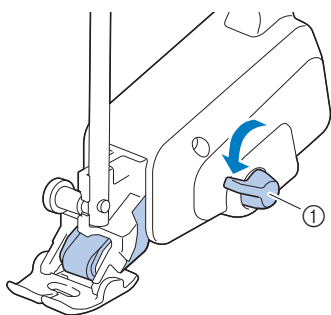

① Feed position lever

Note

- Do not operate the lever while sewing.

Memo

- When the feed position lever is up, dual feed function is not effective. When the feed position lever is down, the black roller belt on the compact dual feed foot is engaged.

■ Attaching/Detaching Foot

Attach the foot by aligning the pins with the notches and snap it into place.

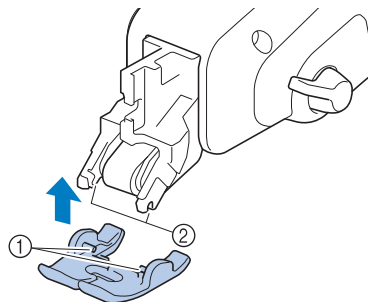

- ① Pins
- ② Notches

To detach, push down on the front and back part of the foot, the foot will snap off.

■ Adjusting the Amount of Fabric Feeding by the Compact Dual Feed Foot

The dual feed mechanism pulls the top fabric according to the set stitch length. With troublesome fabrics, fine tune the set length.

- 1** Touch  to display [Dual Feed Feed Adjustment] of the settings screen.
- 2** Touch the number to select the feeding of the top fabric.

- * Select [00] for sewing in most cases.
- * Touch a higher number to increase the feed amount for the top fabric. Touch a lower number to decrease the feed amount for the top fabric.



Chapter 2 Sewing Basics

2

Sewing Basics

Sewing

Stitch Types

Utility Stitches

Swipe the key of a category sideways to display hidden categories.

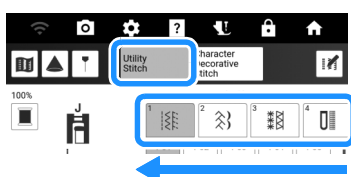

Display	Category Name
	Straight/Overcasting
	Decorative Stitches
	Heirloom Stitches
	Buttonholes/Bar tacks
	Multi-directional Sewing
	Quilting Stitches
	Other Stitches
	Stitch Tapering

Character/Decorative Stitches

Swipe the key of a category sideways to display hidden categories.

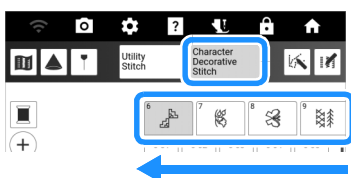

Display	Category Name
	Wide and Various
	Wide Botanical
	Wide Motifs and Messages
	Narrow and Various
	Narrow Botanical
	Candlewicking

Display	Category Name
	Large Satin
	Satin
	Cross Stitches
	Combinable Utility
	Disney * Disney stitch patterns contained in this product are for personal non-commercial use only. No license is granted for any commercial use of these patterns and any such use is strictly prohibited.
	Alphabet Characters (Gothic Font)
	Alphabet Characters (Handwriting Font)
	Alphabet Characters (Outline Font)
	Cyrillic font
	Pocket (Machine's and external memory) (page 64)

Basic Sewing

CAUTION

- To avoid injury, pay special attention to the needle while the machine is in operation. Keep your hands away from moving parts while the machine is in operation.
- Do not stretch or pull the fabric during sewing. Doing so may lead to injury.
- Do not use bent or broken needles. Doing so may lead to injury.
- Do not attempt to sew over basting pins or other objects during sewing. Otherwise, the needle may break and cause injury.

IMPORTANT

- If stitches become bunched, lengthen the stitch length setting before continuing sewing. Otherwise, the needle may bend or break.

Note

- First, perform a trial sewing, using a piece of fabric and thread that are the same as those used for your project.

1 Touch [Sewing] in the home page screen to display the utility stitches. If the needle is lowered, press  (Needle position button) to raise the needle.

2 Select the category, and then touch the key of the stitch you want to sew.

* Swipe the key of a category sideways to display hidden categories.

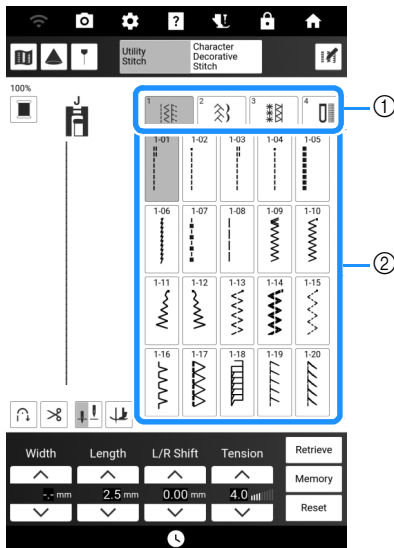

① Category
 ② Key of the stitch
 → The symbol of the correct presser foot will be displayed in the upper left corner of the LCD screen.

3 Check which presser foot is indicated in the upper-left corner of the screen, and then attach it. (page 48)

4 Set the fabric under the presser foot. Hold the fabric and thread in your left hand, and press  (Needle position button) to set the needle in the sewing start position.

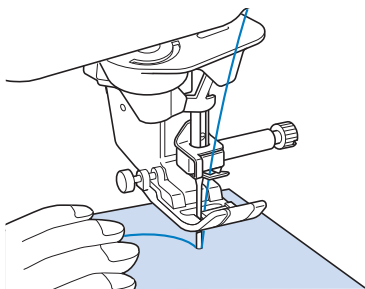

5 Lower the presser foot.

* You do not have to pull up the bobbin thread.

6 Adjust the sewing speed with the speed control slide.

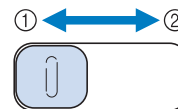

① Slow
 ② Fast

7 Press the “Start/Stop” button to start sewing.

* Guide the fabric lightly by hand.

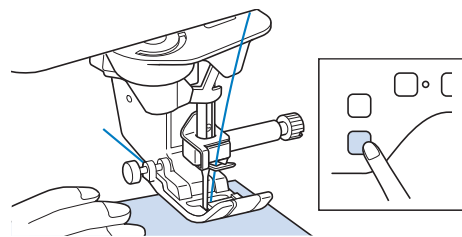

Memo

• When the foot controller is being used, you cannot start sewing by pressing the “Start/Stop” button.

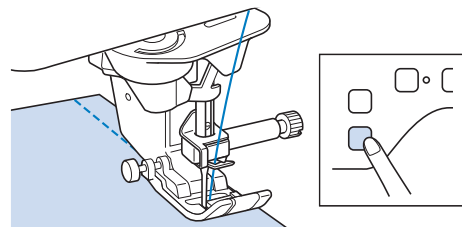

8 Press the “Start/Stop” button again to stop sewing.

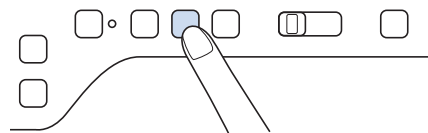

9 Press  (Thread cutter button) to trim the upper and bobbin threads.



IMPORTANT

- Do not press  (Thread cutter button) after the threads have been cut. Doing so could tangle the thread or damage the machine.
- Do not press  (Thread cutter button) when there is no fabric set in the machine or during machine operation. The thread may tangle, possibly resulting in damage.

Note

- When cutting thread such as nylon monofilament thread, or other decorative threads, use scissors.

- 10** When the needle has stopped moving, raise the presser foot and remove the fabric.

Using Advanced Multi-Function Foot Controller

With the advanced multi-function foot controller, various sewing machine operations in addition to starting/stopping sewing, such as thread cutting and reverse stitching, can be specified to be performed.

Note

- (For U.S.A. only) Foot controller: Model X
This foot controller can be used on the machine with product code 882-W40/W42. The product code is mentioned on the machine rating plate.

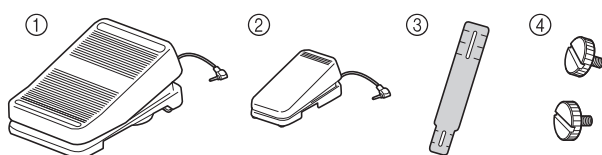

- ① Main foot controller
② Side pedal
③ Mounting plate
④ Mounting screw × 2

- 1** Align the smaller end of the mounting plate with the guide on the bottom of the side pedal, and then gently fasten them together with the mounting screw. Align the larger end of the mounting plate with the guide on the bottom of the main foot controller, and then gently fasten them together with the mounting screw.

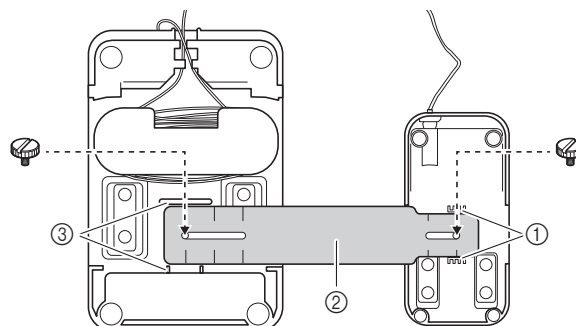

- ① Guide on side pedal
② Mounting plate
③ Guide on main foot controller

Memo

- The side pedal can be mounted on either the left or right side of the main foot controller.
- The main foot controller and side pedal can also be used without installing the mounting plate.

- 2** Adjust the spacing between the main foot controller and side pedal.

- * Use the markings on the mounting plate as a convenient guide to adjust the spacing.

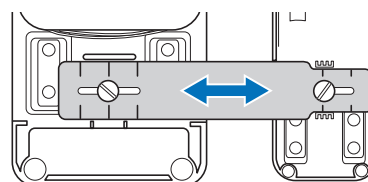

- 3** Firmly tighten the mounting screws to secure the main foot controller and side pedal.

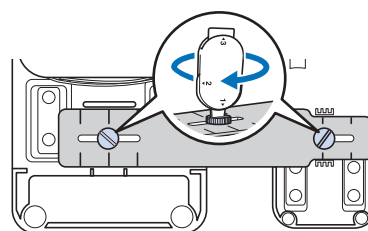
**Memo**

- To readjust the spacing between the main foot controller and side pedal, slightly loosen the mounting screws, and then adjust the positions of the main foot controller and side pedal.

4 Insert the plug for the side pedal into the jack on the main foot controller.

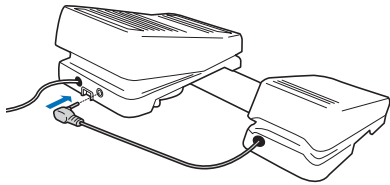

5 Insert the plug for the main foot controller into the foot controller jack on the right side of the machine.

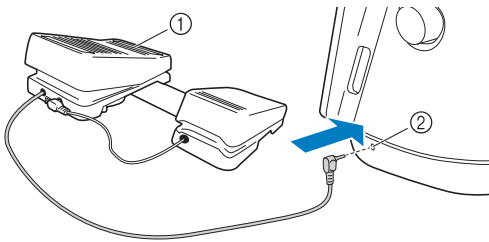

- ① Main foot controller
- ② Foot controller jack

Memo

- The length of the cord for the main foot controller can be adjusted. (page 55)

6 Turn on the machine. And then touch and display [Multi function Foot Controller] of the settings screen.

7 Select the functions to be performed by the multi-function foot controller.

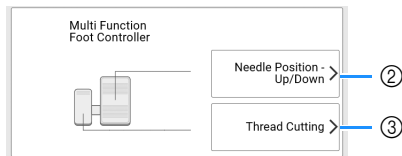
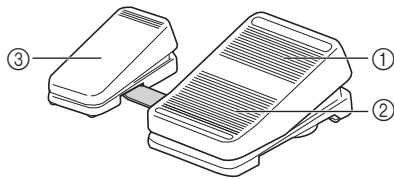

	Controller	Functions that can be specified
①	Main foot controller	Start/Stop
②	Heel switch	Select any of the following: <ul style="list-style-type: none"> • [Thread Cutting] • [Needle Position – Up/Down]
③	Side pedal	<ul style="list-style-type: none"> • [Single Stitch] • [Reverse Stitch] (Reinforcement stitching may be applied depending on the selected stitch pattern. (page 56)) • [Reinforcement Stitch] • [Presser Foot Up/Down] • [No Setting]

Memo

- If you set [Reverse Stitch] on the side pedal, you can create a darning stitch effect using zigzag stitches. With both feet, keep pressing the main foot controller, and repeat pressing and releasing the side pedal to sew forward and reverse in turn. Machine will reverse at the speed you press the main foot controller.

8 Touch [OK].

9 Sew trial stitches and confirm that the settings are as desired.

Pressing down on the main foot controller increases the sewing speed; releasing the pressure on the main foot controller decreases the sewing speed. Release the main foot controller or side pedal to stop sewing.

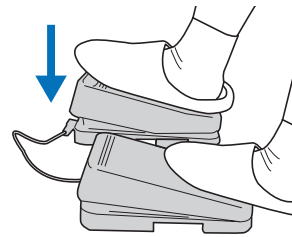

Memo

- The speed that is set using the sewing speed controller will be the main foot controller's maximum sewing speed.
- When the multi-function foot controller is connected, the "Start/Stop" button cannot be used to start sewing.

■ Adjusting the Length of the Cord for the Main Foot Controller

- 1 Unwind the cord for the main foot controller.
- 2 Guide the cord between the tabs and then wind the cord until it is the desired length.

* The cord can be wound either clockwise or counterclockwise.

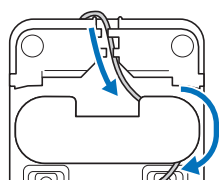

- 3 Pass the cord between the tabs.

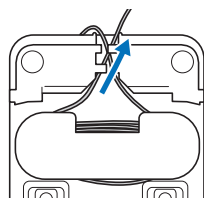

Note

- In order to avoid stepping on the cord with the main foot controller, pass the cord between the tabs.

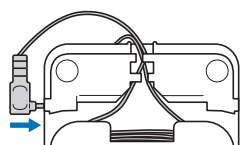

Memo

- When storing the cord, pass it between the tabs, and then insert the plug into the jack on the main foot controller.





Sewing Reverse/Reinforcement Stitches

Reverse/reinforcement stitches are generally necessary at the beginning and end of sewing.

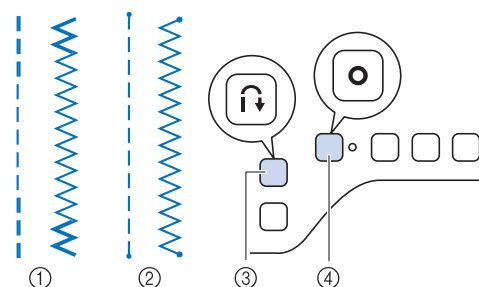

You can use  (Reverse stitch button) to sew reverse/reinforcement stitches. When you keep pressing  (Reinforcement stitch button), the machine will sew reinforcement stitch at that point 3 to 5 stitches, and then stop. (page 14)



- ① Reverse stitch
- ② Reinforcement stitch
- ③  (Reverse stitch button)
- ④  (Reinforcement stitch button)

The operation performed when the button is pressed differs depending on the selected stitch pattern. (Refer to the table of “The Operation Performed When the “Reverse Stitch” or “Reinforcement Stitch” is Pressed” on page 57.)

Memo

- When you press  (Reinforcement stitch button) while sewing character/decorative stitch pattern, you can end sewing with a full stitch instead of at a mid-point. The green light on the right of  (Reinforcement stitch button) lights up while the machine is sewing a full motif, and it automatically turns off when the sewing is stopped.

Automatic Reverse/Reinforcement Stitching

After selecting a stitch motif, turn on the automatic reinforcement stitching function before sewing, and the machine will automatically sew reinforcement stitches (or reverse stitches, depending on the stitch selected) at the beginning and end of sewing.

- 1 Select a stitch pattern.
- 2 Touch  to set the automatic reinforcement stitching function.

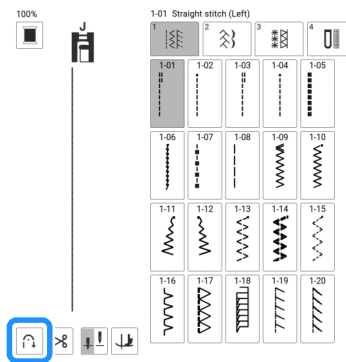

→ The key will display as .

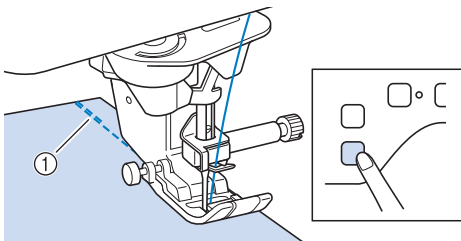

- 3 Set the needle into the fabric, and then press the “Start/Stop” button.



- ① Reverse stitches (or reinforcement stitches)
→ The machine will automatically sew reverse stitches (or reinforcement stitches) and then continue sewing.

Memo

- Pressing the “Start/Stop” button while the machine is sewing pauses or restarts sewing.

- 4 When the end of stitching has been reached, press  (Reverse stitch button) or  (Reinforcement stitch button).

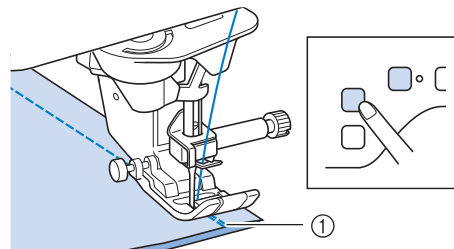











- ① Reverse stitches (or reinforcement stitches)
→ The machine will sew reverse stitches (or reinforcement stitches) and stop.











Memo

- To turn off the automatic reinforcement stitching function, touch .

■ The Operation Performed When the “Reverse Stitch” or “Reinforcement Stitch” is Pressed

The operation performed when the button is pressed differs depending on the selected stitch pattern.

	 (Reverse stitch button)	 (Reinforcement stitch button)
Automatic reverse/reinforcement stitching function is not active.		
Utility Stitch 1-01 1-03 1-09	Machine sews reverse stitches while holding  .	Machine sews 3 – 5 reinforcement stitches while holding  .
Utility Stitch 1-02 1-04 1-10 Stitch patterns with a dot mark at the top	Machine sews reverse stitches while holding  .	Machine sews 3 – 5 reinforcement stitches while holding  .
Utility Stitch Other than straight/zigzag stitch patterns	Machine sews 3 – 5 reinforcement stitches while holding  .	Machine sews 3 – 5 reinforcement stitches while holding  .
Character Decorative Stitch	Machine sews 3 – 5 reinforcement stitches while holding  .	Machine sews 3 – 5 reinforcement stitches while holding  At the end of sewing, when  is pressed, the LED beside the button lights up, machine completes the stitch pattern, stops sewing, then sews reinforcement stitches.

	 (Reverse stitch button)	 (Reinforcement stitch button)
Automatic reverse/reinforcement stitching function is active.		
Utility Stitch 1-01 1-03 1-09	At the beginning of sewing, reverse stitches are sewn automatically when “Start/Stop” button is pressed. At the end of sewing, reverse stitches are sewn when  is pressed.	At the beginning of sewing, reverse stitches are sewn automatically when “Start/Stop” button is pressed. At the end of sewing, reinforcement stitches are sewn when  is pressed.
Utility Stitch 1-02 1-04 1-10 Stitch patterns with a dot mark at the top	At the beginning of sewing, reinforcement stitches are sewn automatically when “Start/Stop” button is pressed. At the end of sewing, reverse stitches are sewn when  is pressed.*	At the beginning of sewing, reinforcement stitches are sewn automatically when “Start/Stop” button is pressed. At the end of sewing, reinforcement stitches are sewn when  is pressed.
Utility Stitch Other than straight/zigzag stitch patterns	At the beginning of sewing, reinforcement stitches are sewn automatically when “Start/Stop” button is pressed. At the end of sewing, reinforcement stitches are sewn when  is pressed.	At the beginning of sewing, reinforcement stitches are sewn automatically when “Start/Stop” button is pressed. At the end of sewing, reinforcement stitches are sewn when  is pressed.
Character Decorative Stitch	At the beginning of sewing, reinforcement stitches are sewn automatically when “Start/Stop” button is pressed. At the end of sewing, reinforcement stitches are sewn when  is pressed.	At the beginning of sewing, reinforcement stitches are sewn automatically when “Start/Stop” button is pressed. At the end of sewing, when the  is pressed, the LED beside the button lights up, machine completes the stitch pattern, stops sewing, then sews reinforcement stitches.

* If [Reinforcement Priority] of the settings screen is set to on (page 22), reinforcement stitches are sewn instead of reverse stitches.

Automatic Thread Cutting

The machine can be set to automatically cut the threads at the end of the stitching. If automatic thread cutting is set, automatic reverse/reinforcement stitching is also set.

- 1 Select a stitch pattern.
- 2 Touch  to set the automatic thread cutting function.

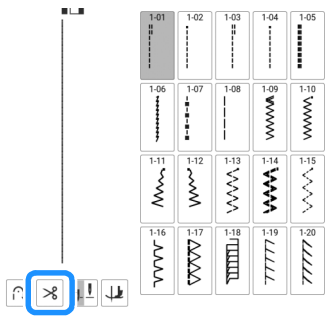

→ The keys will display as  , and the machine is set for automatic thread cutting function and automatic reverse/reinforcement stitching.

Memo

- To turn off the automatic thread cutting function, touch  again.

- 3 Set the needle in the start position, and press the “Start/Stop” button.



→ The machine will automatically sew reverse stitches (or reinforcement stitches) and then continue sewing.

- 4 Once you have reached the end of the stitching, press  (Reverse stitch button) or  (Reinforcement stitch button) once.

If stitching, such as buttonholes and bar tacking, that includes reinforcement stitching has been selected, this operation is unnecessary.

→ After the reverse stitching (or reinforcement stitching) has been done, the machine stops, and the threads are cut.



- ① The point where the “Start/Stop” button was pressed.
- ② The point where  (Reverse stitch button) or  (Reinforcement stitch button) was pressed.
- ③ The thread is cut here.



Automatic Presser Foot Lift Function

By setting the machine to automatically raise and lower the presser foot, sewing operations can be performed more smoothly. Touch  to display [Automatic Presser Foot Lift] of the settings screen.



- ① When set to on, pressing the “Start/Stop” button or depressing the foot controller automatically lowers the presser foot (if it is raised) before starting to sew.
- ② When set to on, pressing  (Thread cutter button) automatically lowers the presser foot (if it is raised) before cutting the thread. The presser foot will be raised after the thread is cut.

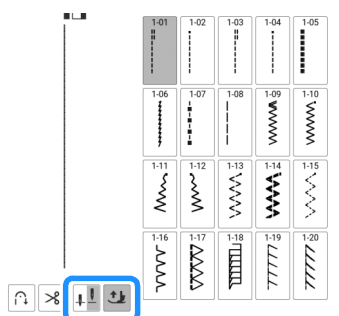

Automatic Presser Foot Raising Function

When the needle position is set to , auto up key appears instead of pivot key. When the auto up key is set to , the presser foot and needle are raised automatically if the machine is stopped.





Returning to the Beginning of the Stitch Pattern

Even if you stopped stitching while sewing, you can return to the beginning of the stitch pattern. This function is useful after trial sewing or when the stitching is sewn incorrectly.

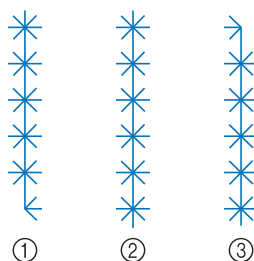
Touch  then  before start sewing to return to the beginning of the stitch.





- ① Stop stitching
- ② Re-start stitching ( was touched.)
- ③ Re-start stitching ( was not touched.)

Editing Character/Decorative Stitches

Combining Various Stitch Patterns

Example:



- 1 Select  and then touch  so that it displays .

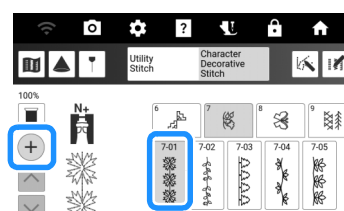

- 2 Select a font.

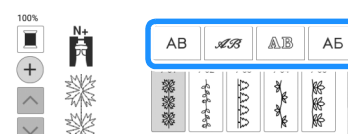



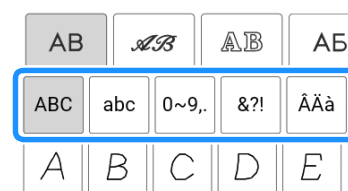

- 3 Touch the tab to select a character type.

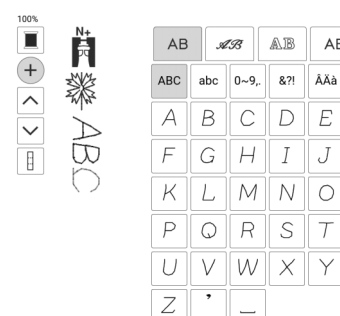

- 4 Enter characters.

* To enter a space, touch .



- 5** Touch , then touch  so that it displays  to sew the stitch pattern continuously.

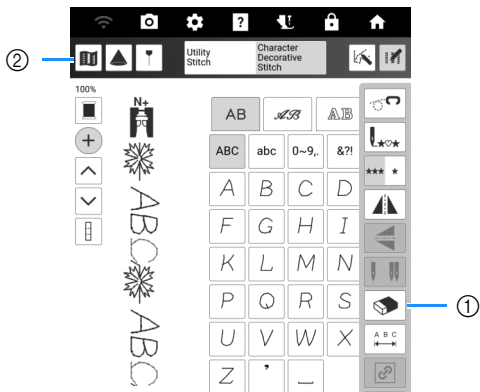

- ① Touch  to delete the last stitch pattern entered. To delete other stitch pattern, touch  or  to select the desired stitch pattern before touching .
- ② Touch this key to view an image of the entire combined stitch pattern.

Memo

- When sewing is completed, trim any excess thread between characters.

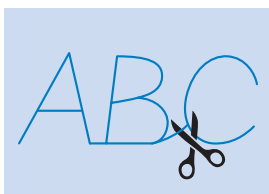

Inserting Stitch Patterns

- 1** Touch  or  to select the stitch pattern in front of the stitch pattern which new stitch patterns will be added.

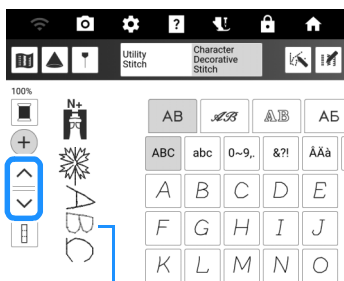

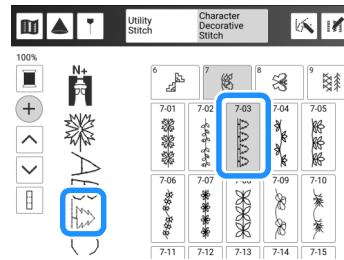

① Selected pattern

- 2** Select a new stitch pattern.



→ The new stitch pattern is added immediately after the stitch pattern selected in step 1.

Changing the Size

Select a stitch pattern, then touch  or  to change the stitch width and stitch pattern length.

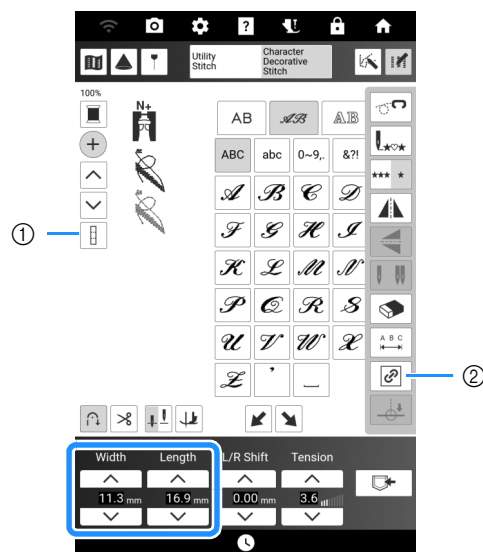

- ① When the select all on/off key appears as , the size of all stitch patterns can be changed.



- ② When the maintain aspect ratio key appears as , the stitch pattern size can be changed while maintaining the aspect ratio.



Stitch Settings

Setting the Stitch Width/Stitch Length/"L/R Shift"

When you select a stitch, your machine automatically selects the appropriate stitch settings. However, if needed, you can change any of the individual settings.

Note

- After adjusting the stitch width or the "L/R Shift", slowly turn the handwheel toward you (counterclockwise) and check that the needle does not touch the presser foot.

Memo

- Touch [Reset] to return the setting to its default.
- Settings for some stitches cannot be changed.
- If you turn off the machine or select another stitch without saving stitch setting changes (page 63), the stitch settings will return to their default settings.

Setting the Stitch Width

Touch or to make the stitch wider or narrower.

Width	Length	L/R Shift	Tension	Retrieve
▲	▲	▲	▲	Memory
3.5 mm	1.4 mm	0.00 mm	4.0 μ m	Reset
▼	▼	▼	▼	

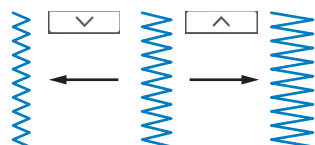

Setting the Stitch Length

Touch or to make the stitch coarser (longer) or finer (shorter).

IMPORTANT

- If the stitches get bunched together, lengthen the stitch and continue sewing. Do not continue sewing without lengthening the stitch. Otherwise, the needle may bend or break.

Width	Length	L/R Shift	Tension	Retrieve
▲	▲	▲	▲	Memory
2.5 mm	2.5 mm	0.00 mm	4.0 μ m	Reset
▼	▼	▼	▼	

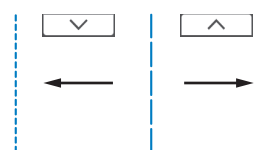

Setting the [L/R Shift]

Touch or to change the placement of the stitch pattern by moving it left and right.

Width	Length	L/R Shift	Tension	Retrieve
▲	▲	▲	▲	Memory
3.5 mm	1.4 mm	0.00 mm	4.0 μ m	Reset
▼	▼	▼	▼	

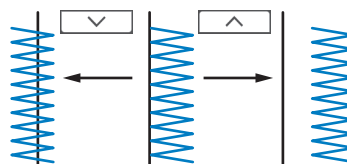

Setting the Thread Tension

You may need to change the thread tension, depending on the fabric and thread being used.

Width	Length	L/R Shift	Tension	Retrieve
^	^	^	^	Memory
2.5 mm	2.5 mm	0.00 m	4.0	Reset
v	v	v	v	

■ Proper Thread Tension

The upper thread and the bobbin thread should cross near the center of the fabric. Only the upper thread should be visible from the right side of the fabric, and only the bobbin thread should be visible from the wrong side of the fabric.

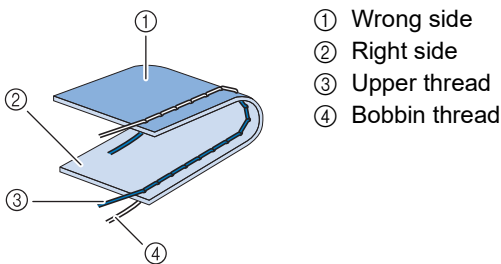

- ① Wrong side
- ② Right side
- ③ Upper thread
- ④ Bobbin thread

📖 Memo

- Many decorative stitches and satin stitches are designed so that the upper thread wraps to the back slightly for a more attractive finish.

■ Upper Thread is Too Tight

If the bobbin thread is visible from the right side of the fabric, the upper thread is too tight.

Touch to loosen the upper thread.

💡 Note

- If the bobbin thread was incorrectly threaded, the upper thread may be too tight. Rethread the bobbin thread. (page 40)

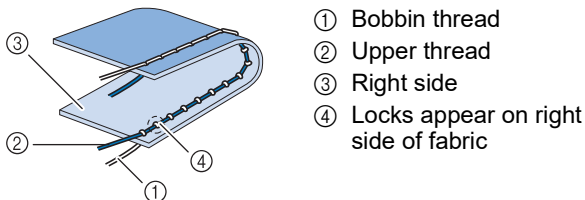

- ① Bobbin thread
- ② Upper thread
- ③ Right side
- ④ Locks appear on right side of fabric

■ Upper Thread is Too Loose

If the upper thread is visible from the wrong side of the fabric, the upper thread is too loose.

Touch to tighten the upper thread.

💡 Note

- If the upper thread was incorrectly threaded, the upper thread may be too loose. Rethread the upper thread. (page 42)

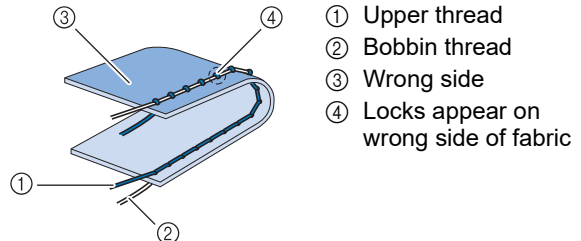

- ① Upper thread
- ② Bobbin thread
- ③ Wrong side
- ④ Locks appear on wrong side of fabric

Saving the Utility Stitch Settings

Mirror image, twin needle, stitch width, stitch length, L/R Shift and thread tension settings can be saved for each stitch pattern.

■ Saving Settings

- 1 Select a stitch.
- 2 Specify your preferred settings.

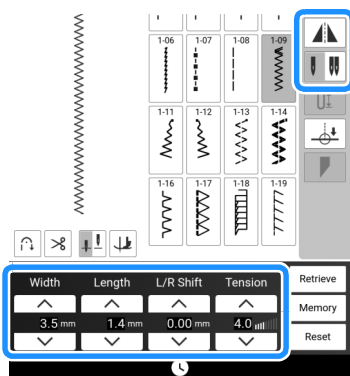

- 3 Touch [Memory].



→ The settings are saved and the original screen automatically appears.

Memo

- Touch [Reset] and then [Memory] to return the selected stitch pattern saved settings to the default settings.
- If you touch [Memory] when there are already 5 sets of settings saved for a stitch, a message appears. Touch [OK] to close the message, and then touch [Retrieve] to delete a setting referring to "Retrieving Saved Settings" on page 63. Touch [Memory] again to save the settings.

■ Retrieving Saved Settings

- 1 Select a stitch.
- 2 Touch [Retrieve].
- 3 Touch the numbered key of the settings to be retrieved and then touch [Retrieve].

* Touch [Close] to return to the original screen without retrieving settings.

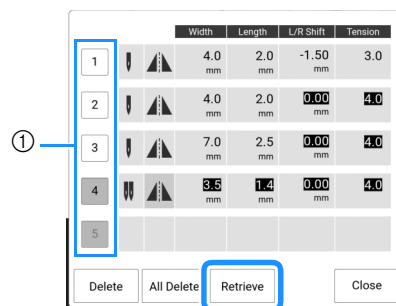

- ① Numbered keys

→ The selected settings are retrieved, and the original screen automatically appears.

Memo

- Touch [Delete] to delete the settings of the selected number.
- You can delete all the saved settings by touching [All Delete].

Using the Memory Function (Sewing)

Saving Character/Decorative Stitch Patterns

You can save often-used stitch patterns in the machine's memory or USB media.

1 Touch .



2 When saving the stitch pattern in a USB media, insert the USB media into the USB port on the machine.

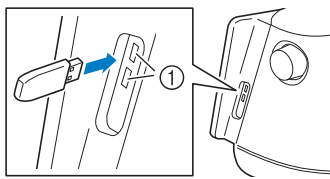

① USB ports

3 Touch the desired destination to start saving.

- * If two USB media are connected to the machine, check the USB media names that are displayed, and then touch the name of the USB media that you wish to use.

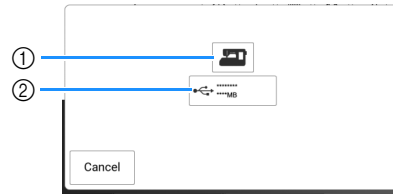

- ① Save to the machine's memory.
- ② Save to the USB media.
The stitch pattern is saved in a folder labeled [bPocket].

Note

- Do not turn the main power to OFF while the [Saving...] screen is displayed. You will lose the stitch pattern you are saving.

Memo

- For more information about the memory function, refer to "Specifications" on page 271.

Retrieving Stitch Patterns

Retrieve stitch patterns saved in the machine's memory or USB media.

1 When retrieving stitch patterns from a USB media, insert the USB media into the USB port on the machine.

- * For details on supported file extensions, refer to "Specifications" on page 271.

2 Touch  and touch the desired destination.

In this case, touch .

- * If two USB media are connected to the machine, check the USB media names that are displayed, and then touch the name of the USB media that you wish to use.

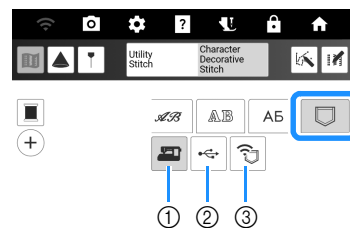

- ① Retrieve from the machine's memory.
- ② Retrieve from a USB media.
- ③ Retrieve stitch patterns via the wireless network. For detailed procedures, refer to PE-DESIGN manual (Version 11 or later).

Memo

- If the stitch pattern to be retrieved is in a folder of the USB media, touch the key for that folder.

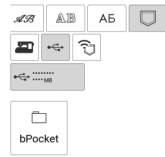

3 Touch the key of the stitch pattern you want to retrieve.

- * Touch to return to the previous folder.

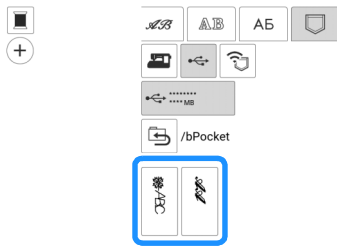

Memo

- You can delete the saved stitch patterns or save to machine's memory from USB media by touching .

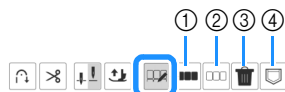
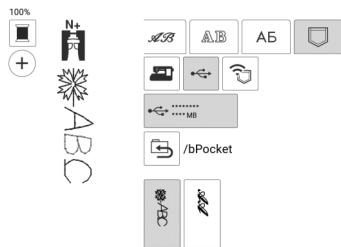

- ① Touch to select all displayed stitch patterns.
- ② Touch to deselect all selected stitch patterns.
- ③ Touch to delete the selected stitch patterns.
- ④ Touch to save the selected stitch patterns in the machine's memory.

Projecting the Guidelines onto the Fabric

Specify the Guidelines

With the guideline function, sewing can easily be done by following the lines and marks projected onto the fabric.

1 Touch .



→ The guideline settings screen appears.

2 Specify the guideline settings.

Main Guideline

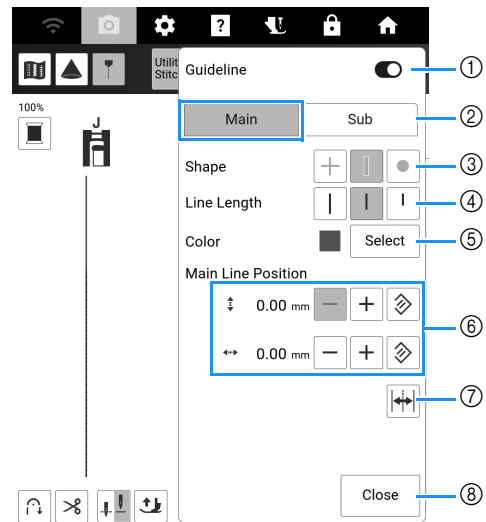

- ① Set the guideline function to on or off.
- ② Select the guideline whose settings are to be specified.
- ③ Select a cross, a line or a point as the shape of the guideline marker.
- ④ Select the length of the main guideline.
- ⑤ Select the color of the main guideline.
- ⑥ Specify the position of the main guideline. In order to reset the position, touch .
- ⑦ Touch to flip the main guideline position on the center needle position.
- ⑧ Touch to finish specifying the guideline settings.

■ Sub Guidelines

📖 Memo

- Touch  to return the setting to its default.

□ Sub Guideline

A straight-line guideline is displayed.

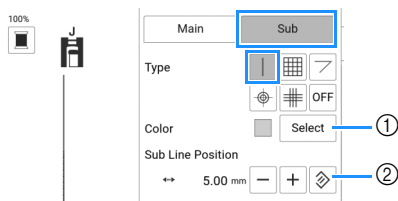

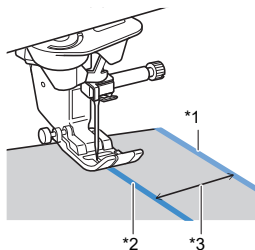

- ① Select the color of the sub guideline.
- ② Specify the sub guideline position (distance from the main guideline).



- *1 Sub guideline
- *2 Main guideline
- *3 Distance specified with [Sub Line Position] (②)

📖 Memo

- When  or  is selected, the position of the sub guideline is based on the position of the main guideline. In order to move the two guidelines without changing the spacing between the main guideline and the sub guideline, change the position of the main guideline.

□ Sub Guideline

A grid guideline is displayed.

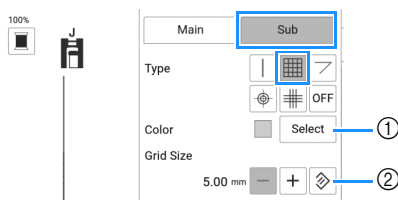

- ① Select the color of the sub guideline.
- ② Specify the grid spacing of the sub guideline.

□ Sub Guideline

Guidelines for sewing angled quilt pieces are displayed.

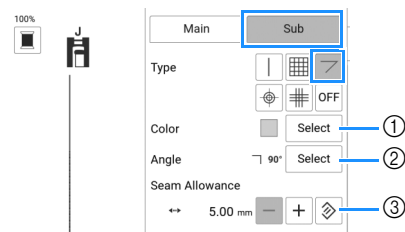

- ① Select the color of the sub guideline.
- ② Specify the angle of the sub guideline. (*3)
- ③ Specify the seam allowance of the sub guideline. (*4)

Sewing quilt pieces together with their right sides together (when the starting point of sewing is at the intersection of seam lines)

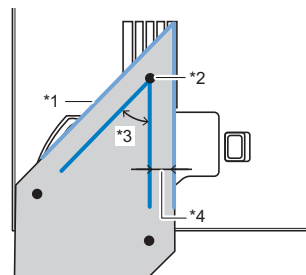

- *1 Align the sub guideline with the edge of the quilt piece.
- *2 Start sewing from the intersection with the main guideline.
- *3 Angle specified with [Angle] (②)
- *4 Distance specified with [Seam Allowance] (③)

Sub Guideline 

Concentric circles are displayed.

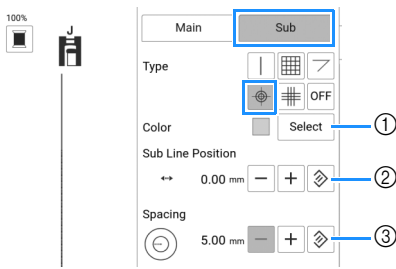

- ① Select the color of the sub guideline.
- ② Specify the position of the concentric circles (distance from the main guideline (*3)).
- ③ Specify the size of the concentric circles (*4).

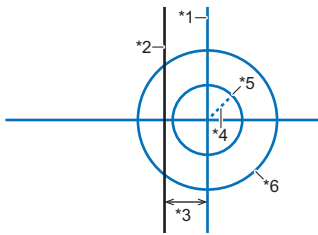

- *1 Sub guideline
- *2 Main guideline
- *3 Distance specified with [Sub Line Position] (②)
- *4 Radius specified with [Spacing] (③)
- *5 Circle whose radius is the length specified with ③
- *6 Circle whose radius is twice the length specified with ③

Sub Guideline 

Displays a 3-lined crosshatch.

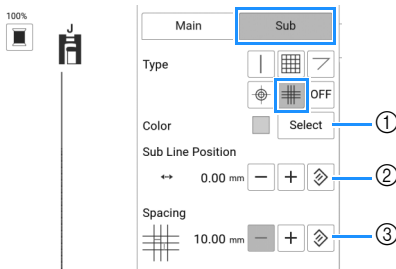

- ① Select the color of the sub guideline.
- ② Specify the position of the 3-lined crosshatch (distance from the main guideline (*3)).
- ③ Specify the size of the 3-lined crosshatch.

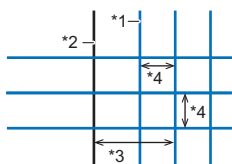

- *1 Sub guideline
- *2 Main guideline
- *3 Distance specified with [Sub Line Position] (②)
- *4 Length specified with [Spacing] (③)

Piecing Using Guidelines

- 1 Select stitch Q-01 [Piecing stitch (Middle)], and then touch .
- 2 Make sure that the guideline position for [Main] aligns with the stitch pattern displayed in the screen.

Memo

- If [Initial Position] in the settings screen is set to , set [Main Line Position] to 3.50 mm in order to align the guideline with the middle needle position of the stitch pattern.

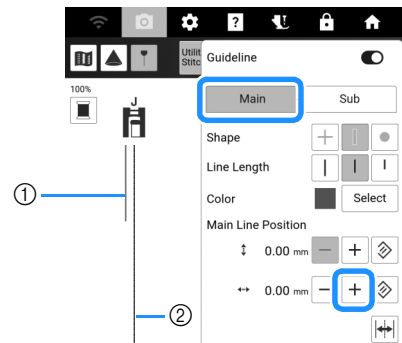

- ① Main guideline
- ② Stitch pattern

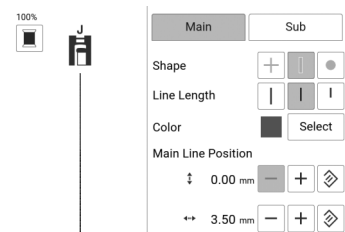

- 3 Set [Sub Line Position] of [Sub] to 6.35 mm (approx.1/4 inch).

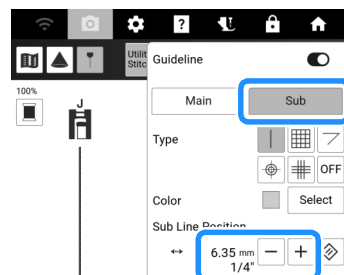

- 4 Touch [Close].
- 5 Align the edge of the fabric with the sub guideline and sew 6.35 mm (approx.1/4 inch) seams.

* For details, refer to "Sub Guidelines" on page 66.

Buttonhole Guidelines

■ When Arranging Buttonholes Vertically

- 1 **Select a buttonhole stitch. Attach buttonhole foot “A+” and pull out the button holder plate on the presser foot, and insert the button.**

* For details, refer to “One-Step Buttonholes” on page 87.

- 2 **Touch** .

Memo

- Touch  to project the selected stitch pattern along with the guidelines. (page 71)

- 3 **Press**  (Presser foot lifter button) to lower buttonhole foot “A+”.



→ The buttonhole length is reflected in the guidelines.

Memo

- When buttonhole foot “A+” is lowered, the buttonhole length is reflected in the projection.

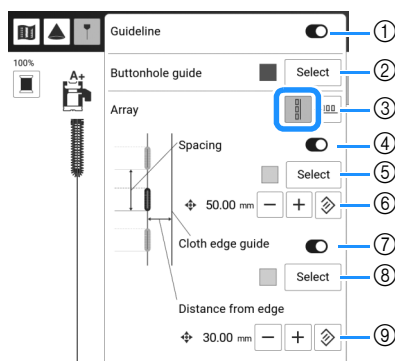
- 4 **Touch**  and then specify the guideline settings.



- ① Turn on or off the guideline function. When this function is turned on, the main guidelines (*1, *2) in addition to the sub guidelines (*4, *5) that are turned on will be projected.
- ② Select the color of the main guidelines (*1, *2).
- ③ Switches the direction in which buttonholes are placed.
- ④ Turn on or off the sub guidelines (*4) that show the spacing of the buttonholes.
- ⑤ Change the color of the sub guidelines (*4).
- ⑥ Change the spacing of the buttonholes of the sub guidelines (*3). To reset the spacing, touch .
- ⑦ Turn on or off the sub guideline (*5) that shows the distance from the centerline of the buttonholes to the edge of the fabric.
- ⑧ Change the color of the sub guideline (*5).
- ⑨ Change the distance from the centerline of the buttonholes to the edge of the fabric of the sub guideline (*6). To reset the spacing, touch .

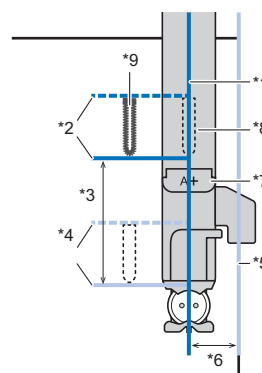



- *1 Centerline of the buttonholes (main guideline)
- *2 Buttonhole length (main guideline)
- *3 Spacing of the buttonholes specified with [Spacing] (6)
- *4 Position of next buttonhole to be sewn (sub guidelines)
- *5 Edge of fabric (sub guideline)
- *6 Distance from the centerline of the buttonholes to the edge of the fabric specified with [Distance from edge] (9)
- *7 Buttonhole foot “A+”
- *8 Position of buttonhole to be sewn
- *9 Touch  to project the selected buttonhole stitch beside the presser foot. (page 71)

- 5 **Touch** [Close].

■ When Arranging Buttonholes Horizontally

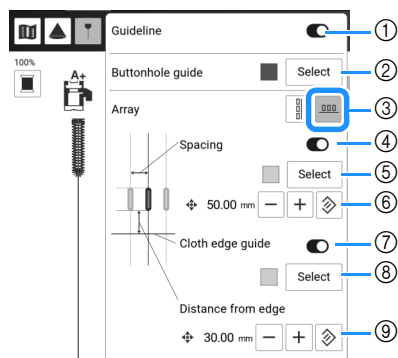
- 1 Follow steps 1 through 3 of “When Arranging Buttonholes Vertically” on page 68.
- 2 Touch  and then specify the guideline settings.



- 1 Turn on or off the guideline function. When this function is turned on, the main guidelines (*1, *2) in addition to the sub guidelines (*4, *5) that are turned on will be projected.
- 2 Select the color of the main guidelines (*1, *2).
- 3 Switches the direction in which buttonholes are placed.
- 4 Turn on or off the sub guidelines (*4) that show the spacing of the buttonholes.
- 5 Change the color of the sub guidelines (*4).
- 6 Change the spacing of the buttonholes of the sub guidelines (*3). To reset the spacing, touch .
- 7 Turn on or off the sub guideline (*5) that shows the distance from the bottom edge of the buttonholes to the edge of the fabric.
- 8 Change the color of the sub guideline (*5).
- 9 Change the distance from the bottom edge of the buttonholes to the edge of the fabric of the sub guideline (*6). To reset the spacing, touch .

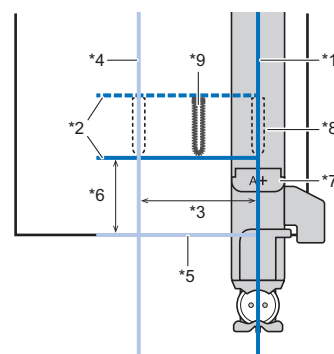

- *1 Centerline of the buttonholes (main guideline)
- *2 Buttonhole length (main guideline)
- *3 Spacing of the buttonholes specified with [Spacing] (6)
- *4 Centerline of next buttonhole to be sewn (sub guideline)
- *5 Edge of fabric (sub guideline)
- *6 Distance from the bottom edge of the buttonholes to the edge of the fabric specified with [Distance from edge] (9)
- *7 Buttonhole foot “A+”
- *8 Position of buttonhole to be sewn
- *9 Touch  to project the selected buttonhole stitch beside the presser foot. (page 71)

3 Touch [Close].

Using the Projector with the Dual Purpose Stylus

Operating the Projector with the Dual Purpose Stylus

Note

- Do not disassemble or modify the dual purpose stylus.
- Do not use metallic objects, such as tweezers or a metallic pen, when changing the battery.

IMPORTANT

- Remove the battery if you do not intend to use the dual purpose stylus for an extended period of time.

- 1 Install a new AAA alkaline battery (LR03) in the dual purpose stylus with the negative end (-) pointing up.**

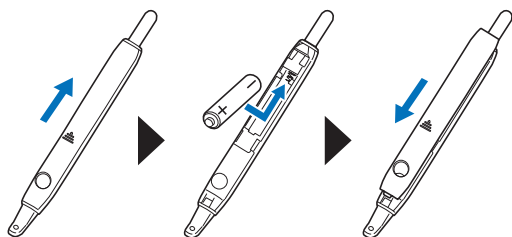

- 2 Press the button to light the dual purpose stylus.**

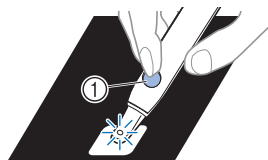

① Button

→ After the built-in camera detects the light, you can operate the projector with the dual purpose stylus.

Note

- Do not put your hand, fabric or any object between the built-in camera and the light-emitting part of the dual purpose stylus, otherwise the built-in camera cannot detect the light from the dual purpose stylus.

Projecting/Editing the Stitch Pattern with the Projector

Using the projector, the selected stitch pattern can be projected onto the fabric.

Memo

- The illustrations of the projections shown in this manual are for illustrative purposes only and may differ from the actual projections.

- 1 Select a stitch pattern.**

- 2 Touch .**

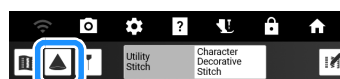

→ The selected stitch pattern and the adjustment keys are projected onto the fabric.

- 3 Place the dual purpose stylus over the key that you wish to operate, and then press the button to turn on the light.**

* After the built-in camera detects the light, you can operate the projector with the dual purpose stylus.

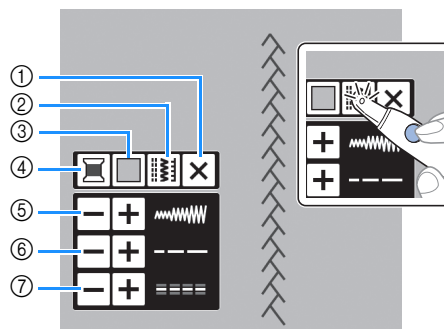

- ① Turn off the projector.
- ② Select a different stitch pattern. (page 71)
- ③ Change the [Background Color] setting.
- ④ Change the thread color displayed on the projection.
- ⑤ Set the stitch width.
- ⑥ Set the stitch length.
- ⑦ Set the [L/R Shift].

Memo

- In the settings screen, settings for the background color of the projector and outline of stitch patterns can be specified. (page 24)

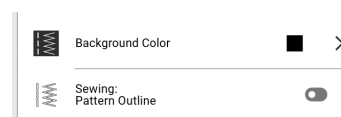



■ Selecting a Stitch Pattern

- 1 Press the button of the dual purpose stylus to turn on the light over .

Memo

- A stitch pattern cannot be selected from the LCD while a stitch pattern is being projected by the projector. In order to select a stitch pattern from the LCD, touch [Cancel] in the screen. The projector is turned off, when touching [Cancel].

- 2 Press the button of the dual purpose stylus over   until the desired stitch pattern is displayed, and then press the button over .

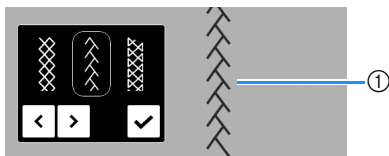

- ① Stitch pattern to be set

■ When selecting a stitch that uses the buttonhole foot

- 1 Select a buttonhole stitch. Attach buttonhole foot “A+” and pull out the button holder plate on the presser foot, and insert the button.

- * For details, refer to “One-Step Buttonholes” on page 87.
- * When a bar tack or darning stitch is selected, set the scale to the length that you wish to sew. For details, refer to “Bar Tacks” on page 93 and “Darning” on page 93.

- 2 Touch .

→ The selected stitch pattern and the adjustment keys are projected onto the fabric.

Memo

- The stitch pattern is projected beside buttonhole foot “A+”.
- When the presser foot is lowered, the adjustment keys are not projected.

- 3 Press  (Presser foot lifter button) to lower buttonhole foot “A+”.

→ The buttonhole length is reflected in the projected stitch pattern.

Memo

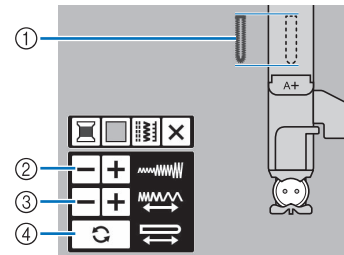

- When buttonhole foot “A+” is lowered, the buttonhole length is reflected in the projection.

- 4 If necessary, use the dual purpose stylus to change the stitch settings.



- ① Projected buttonhole stitch
 ② Set the stitch width.
 ③ Set the stitch length.
 ④ The buttonhole length is reflected in the projection.

Memo

- Buttonhole length can be set by setting [Slit Length] instead of inserting the button on the buttonhole foot “A+”. [Slit Length] can be set by touching , then  on the screen. (page 89)
 When specifying the buttonhole length with [Slit Length], the adjustment keys are projected as shown below.

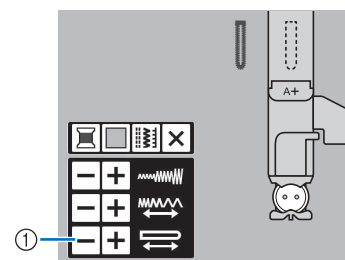

- ① Set the slit length.

Useful Functions

Pivoting

If the pivot function is selected, the machine stops with the needle lowered and the presser foot is automatically raised. This function is useful for stopping the machine to rotate the fabric.

⚠ CAUTION

- When the pivot setting is selected, the machine starts when the “Start/Stop” button is pressed or the foot controller is pressed down even if the presser foot has been raised. Be sure to keep your hands and other items away from the needle, otherwise injuries may occur.

📖 Memo

- The height of the presser foot when sewing is stopped can be changed. Touch  to display [Pivoting Height] of the settings screen and select the height.

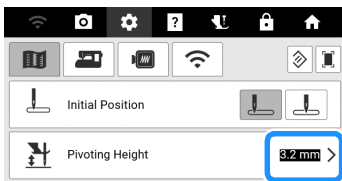

1 Select a stitch.

2 Touch  to select the pivot setting.

- * To use the pivot function, the needle position should be set to .

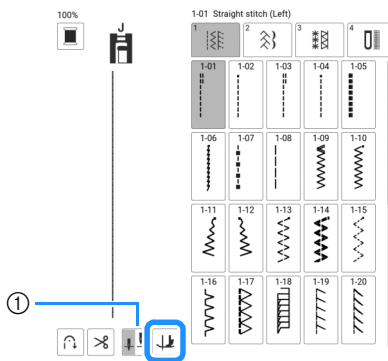

① Needle position setting key

→ The key appears as .

📖 Memo

- If  appears as light gray when the stitch pattern was selected, the pivot function cannot be used.

3 Set the needle in the start position, and press the “Start/Stop” button.

4 Press the “Start/Stop” button to stop the machine at the point where the sewing direction changes.

→ The machine stops with the needle in the fabric, and the presser foot is raised.

5 Rotate the fabric, and then press the “Start/Stop” button.

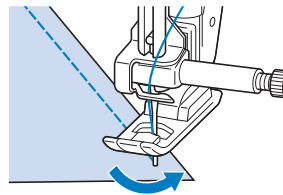

→ The presser foot is automatically lowered, and sewing continues.

Using the Knee Lifter

Using the knee lifter, you can raise and lower the presser foot with your knee, leaving both hands free to handle the fabric.

1 Slide up the knee lifter handle slightly and rotate knee lifter handle till it clicks into the selected position that is most comfortable for you.

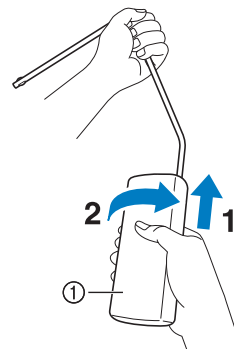

① Knee lifter handle

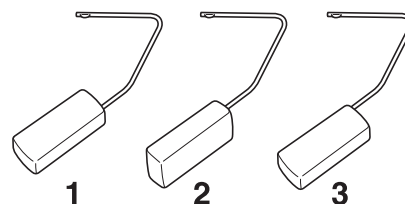

- 2** Align the tabs on the knee lifter with the notches in the knee lifter slot on the front of the machine. Insert the knee lifter bar as far as possible.

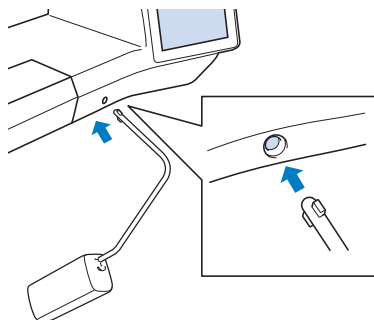

IMPORTANT

- Only change position of the knee lifter handle when knee lifter is not on the machine, otherwise the knee lifter may damage the mounting slot on front of the machine.

Memo

- If the knee lifter bar is not pushed into the mounting slot as far as possible, it may come out during use.

- 3** Use your knee to move the knee lifter bar to the right in order to raise the presser foot. Slowly return the knee lifter bar to the left to lower the presser foot.

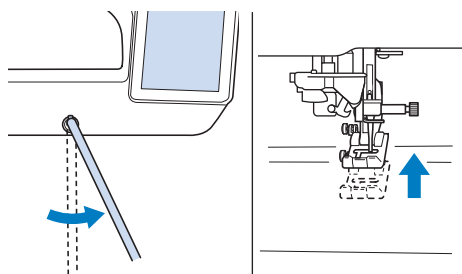

Note

- Be sure to keep your knee away from the knee lifter during sewing.

Automatic Fabric Sensor System (Automatic Presser Foot Pressure)

The thickness of the fabric is automatically detected and the presser foot pressure is automatically adjusted with an internal sensor while sewing, to insure that your fabric is fed smoothly. The fabric sensor system works continuously while sewing. This function is useful for sewing over thick seams (page 78), or quilting (page 111).

Touch , and then set [Automatic Fabric Sensor System] to on. (page 22)

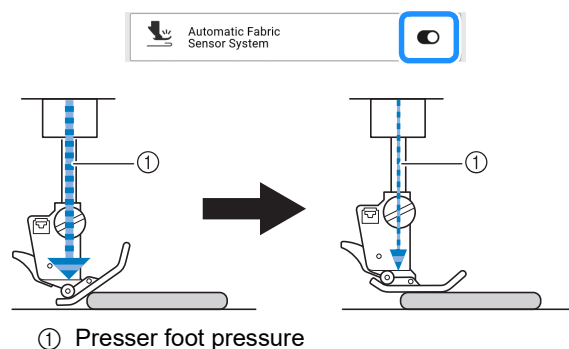

Changing the Stitch Width During Sewing

Set the sewing speed controller to control the stitch width to make subtle changes in the stitch width during sewing. When this function is set, the foot controller must be used to sew.

- 1** Attach the foot controller. (page 53)

- 2** Select  and attach zigzag foot “J”.

- 3** Touch  in the length display to shorten the stitch length.

Width	Length	L/R Shift	Tension	Retrieve
3.50 mm		0.00 mm	4.0	Memory
				Reset

Memo

- The setting will vary according to the kind of fabric and the thickness of the thread, but a length of 0.3 to 0.5 mm (approx. 1/64 to 1/32 inch) is best for satin stitches.

4 Touch  to display [Width Control].

5 Set the [Width Control] to on.



6 Touch [OK].

→ The screen appears as shown below.

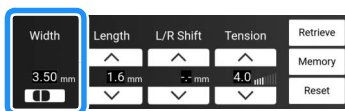

7 While sewing, slide the sewing speed controller to adjust the stitch width.

* Adjust the sewing speed with the foot controller.

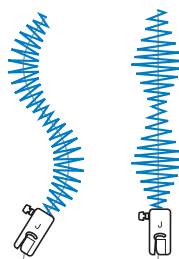

8 When you are finished sewing, set the [Width Control] back to off.

Checking the Needle Location in the Screen

You can check the stitch image with actual fabric image on the screen.

1 Select a stitch, and then touch .

→ An image of the selected stitch and the actual fabric image are displayed.

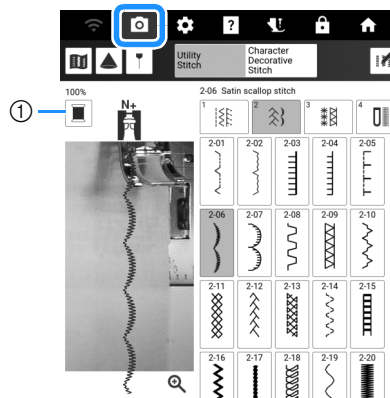

① Change the thread color displayed on the screen.

2 Touch on the fabric image or  on the screen.

→ The camera view window appears.

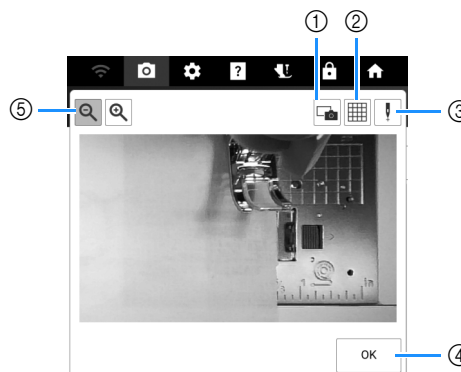

① Touch this key to save a camera image to the USB media.

Insert the USB media to the machine to save a camera image. (page 13)

② Touch this key to display a grid.

③ Lower the presser foot, and then touch . The needle drop point appears in the screen as “+”.

* When moving the fabric, raise the presser foot, and then lower it again afterwards.

④ Touch this key to close the screen.

⑤ Touch  to enlarge the image in the screen.

Touch  again to return the image to its original display size.

Memo

- Touch  again to turn off the camera view.
- The camera view window disappears when you start sewing.
- The needle drop point indicated in the screen may differ from the actual position. In that case, performing the camera needle position setting procedure may resolve the problem. Refer to “Needle Calibration for Camera/Projector” on page 257.

Needle Position - Stitch Placement

Touch , and then set [Needle Position - Stitch Placement] to on. (page 23)



When the [Needle Position - Stitch Placement] is on, the needle will be partially lowered for precise stitch placement and then completely lowered.

Each press of  (Needle position button) button changes the needle to the next position.

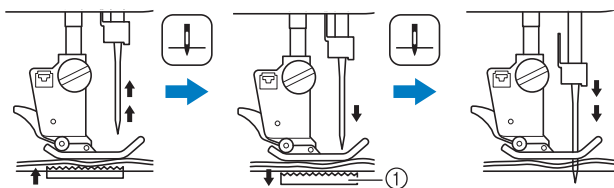

- ① The feed dogs are lowered. At this time, the fabric can be shifted to finely adjust the needle drop point.

Specifying the Sewing End Point

Note

- Using the same material and stitch pattern as your project, sew trial stitches to check the result. The machine's sewing end point may become misaligned in the following cases:
 - The end point sticker is loose.
 - The fabric was not sewn straight.
 - The fabric was pushed too hard during feeding.
 - Fabrics difficult to sew, such as heavyweight, quilted, stretchy, or thin fabrics, were used.

- 1 Select a stitch.
- 2 Touch , make sure that [End Point Setting Temporary Stop] in the settings screen is set to off, and then touch [OK].

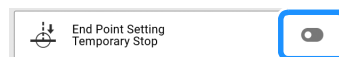

- 3 Touch  to set [Guideline] to on. Set the [Main] line horizontal position according to the selected stitch pattern. And then touch [Close].

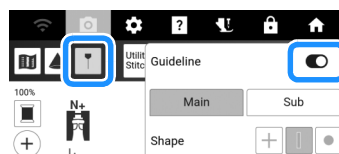

Memo

- If  is selected for [Sub], a grid will be displayed.

- 4 Touch .

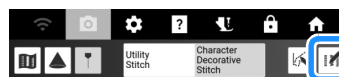



5 Touch .





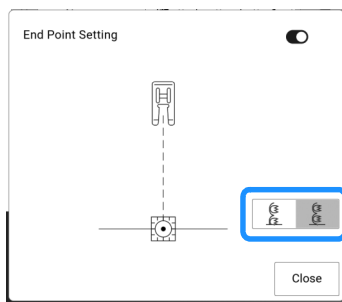

Memo

- If  appears in light gray and is not available, the sewing end point cannot be specified with the selected stitch pattern. Select a different stitch pattern.
- Automatic reinforcement stitching function and automatic thread cutting function cannot be used when using this function.

6 Touch   to select whether or not sewing is ended with a complete stitch pattern. If necessary, touch [Close] after making your selection.



	<p>The length of the stitch pattern is adjusted so that sewing will stop at the specified end point with a complete stitch pattern. If this key appears in light gray and is not available, this function cannot be used. This adjustment may cause the stitch pattern to be sewn slightly stretched vertically.</p>	
	<p>The end of stitching is not adjusted. When the end point is reached, sewing stops immediately, even if the stitch pattern is not complete.</p>	

Memo

- If [End Point Setting] is set to on, the stitch pattern cannot be projected by the projector.
- To cancel [End Point Setting], set [End Point Setting] to off, and then touch [Close].

- 7 With a chalk pencil, mark the fabric with lines for sewing the stitch pattern and for the end of stitching.**
- 8 Affix an end point sticker, avoiding the sewing area. Attach the end point sticker within 4 cm (approx. 1-1/2 inches) to the left or right of the chalkline where the end point for sewing has been drawn.**

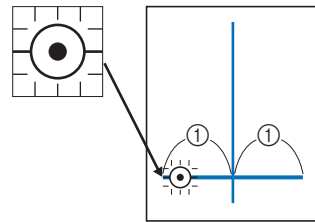

① 4 cm (Approx. 1-1/2 inches)

Memo

- If the end point sticker can be affixed to either left or right of the sewing position, we recommend affixing it to the left side.
- We recommend affixing the end point sticker as close as possible to the sewing position.
- If you cannot affix an end point sticker avoiding the sewing area, refer to “Temporary Stop Setting” on page 77.
- The horizontal guideline at the needle indicates the distance from the stitching line where the end point sticker can be affixed.

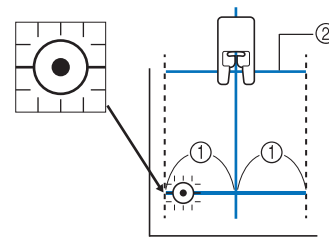

① 4 cm (Approx. 1-1/2 inches)
② Guideline

9 Place the fabric in the machine, and then lower the presser foot.

Note

- Before sewing, make sure that the end point sticker has not become detached. In addition, make sure that the end point sticker is not covered with your hand. Otherwise, the machine cannot detect the end point sticker.

- 10** Press the "Start/Stop" button to start sewing. When the foot controller is plugged in, press down on the foot controller. Gently guide the fabric to sew the stitching straight.

Note

- While making sure that the guidelines align with the lines drawn with the chalk pencil, sew the stitching straight, not at an angle.
- Do not forcefully feed the fabric. Otherwise, sewing may not stop correctly.

→ The machine stops at the specified end point automatically.

Memo

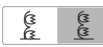
- If the stitch pattern could not be adjusted when  was set in step 6, the following message appears. Cancel [End Point Setting], and then select a different stitch or change the length of the stitch.

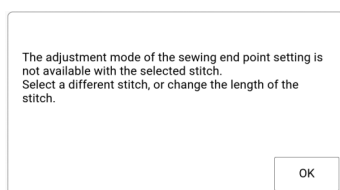

- 11** Peel off the end point sticker.

■ Temporary Stop Setting

If you cannot affix an end point sticker that avoids the sewing area, you can adjust the machine settings to temporarily stop sewing to allow the sticker to be removed as you approach the end point sticker.

- 1** Select a stitch.
- 2** Touch , set [End Point Setting Temporary Stop] in the settings screen to on, and then touch [OK].

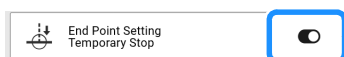

- 3** Follow steps 3 through 6 of "Specifying the Sewing End Point" on page 75.

- 4** With a chalk pencil, mark the fabric with lines for sewing the stitch pattern and for the end of stitching, and then affix an end point sticker.

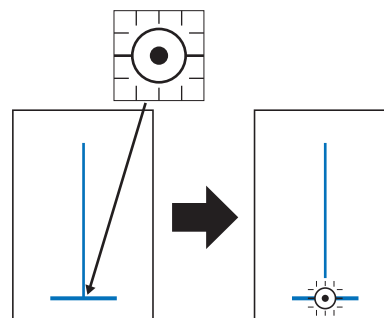

- 5** Follow steps 9 through 10 of "Specifying the Sewing End Point" on page 75.

→ When the needle approaches the mark, the machine stops, and the following message appears.

- 6** Peel off the end point sticker, and then touch [OK].

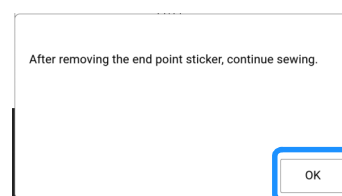

- 7** Press the "Start/Stop" button again. When the foot controller is plugged in, press down on the foot controller.

→ The machine finishes sewing the stitch pattern, then stops.

Useful Sewing Tips

Sewing Tips

■ Sewing Curves

Sew slowly while keeping the seam parallel with the fabric edge as you guide the fabric around the curve.

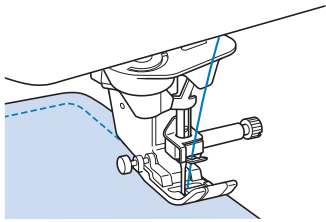

Shorten the stitch length setting to obtain a fine stitch. Sew slowly, keeping the seams parallel with the fabric edge as you guide the fabric around the curve.

■ Changing Sewing Direction

Stop the machine. Leave the needle in the fabric, and press  (Presser foot lifter button) to raise the presser foot. Using the needle as a pivot, turn the fabric so that you can sew in the new direction.

Press  (Presser foot lifter button) to lower the presser foot and start sewing.

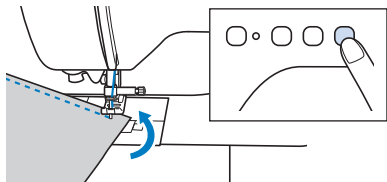

The pivot setting is useful when changing the sewing direction. (page 72)

■ Sewing Cylindrical Pieces

Removing the flat bed attachment allows for free arm sewing, making it easier to sew cylindrical pieces such as sleeve cuffs and pant legs.

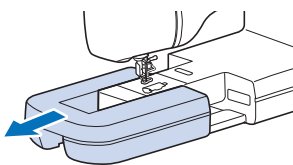

Sewing Various Fabrics

Note

- Sew trial stitches on fabric that is the same as that used in your project, referring to “Fabric/Thread/Needle Combinations” on page 34. While checking the sewing results, adjust the thread tension as well as the stitch length and width according to the number of fabric layers and stitch that is sewn.

■ Sewing Heavyweight Fabrics

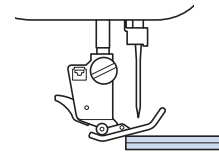

⚠ CAUTION

- Do not forcefully push fabrics through the machine. This may cause the needle to break and cause injury.

Memo

- Thicker fabrics require a larger needle. (page 34)

□ If the Fabric Does Not Fit Under the Presser Foot

If the fabric cannot be smoothly placed under the presser foot there are two options.

Option 1: The presser foot height can be changed in the settings screen. (page 22)

Option 2: The presser foot can be raised higher manually so that the fabric can be placed under the presser foot.

Memo

- You cannot use the presser foot lever after the presser foot has been raised using  (Presser foot lifter button).

□ If the Fabric Does Not Feed

When sewing thick fabric such as denim or quilting layers, the fabric may not feed at the start of sewing if the presser foot is not level. In this case, use the presser foot locking pin (black button on the left side) of zigzag foot "J" so that the presser foot remains level while sewing, allowing the fabric to be fed smoothly.

If the presser foot misalignment is too large, place thick paper or fabric (with the same thickness as the fabric being sewn) under the heel of the presser foot to be able to start sewing smoothly.

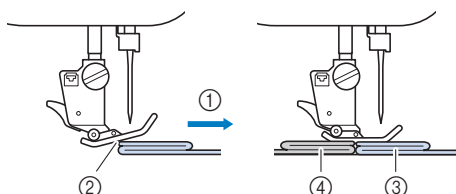

- ① Sewing direction
- ② Misalignment
- ③ Fabric being sewn
- ④ Fabric or thick paper

1 Raise the presser foot.

2 While keeping the black button on the left side of zigzag foot "J" pressed in, press



(Presser foot lifter button) to lower the presser foot.

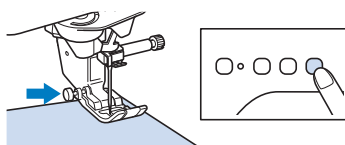

3 Release the black button.

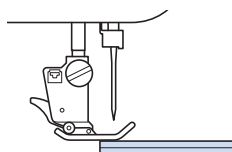

→ The presser foot remains level, enabling the fabric to be fed. Once the trouble spot has been passed, the foot will return to its normal position.

Memo

- When [Automatic Fabric Sensor System] (Automatic Presser Foot Pressure) in the settings screen is set to on, the thickness of the fabric is automatically detected by the internal sensor, so the fabric can be fed smoothly for best sewing results. (page 73)

■ Sewing Lightweight Fabrics

Place thin paper or tear away embroidery stabilizer under thin fabrics to make sewing easier. Gently tear off the paper or the stabilizer after sewing.

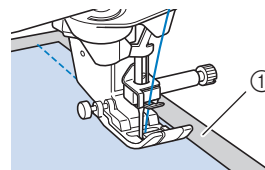

- ① Thin paper

■ Sewing Stretch Fabrics

First, baste together the pieces of fabric, and then sew without stretching the fabric. If the stitching is misaligned, place non-woven water soluble stabilizer under the fabric and sew them together. In addition, a better result can be achieved by using thread for knits or a stretch stitch.

Memo

- For best results when sewing stretch fabrics, decrease the pressure of the presser foot.

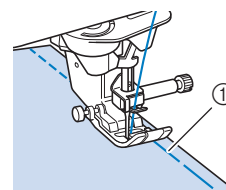

- ① Basting stitching

■ Sewing Leathers or Vinyl Fabrics

When sewing fabrics that may stick to the presser foot, such as leather or vinyl fabrics, replace the presser foot with the compact dual feed foot. (page 49)

If the leather or vinyl fabric sticks to the flat bed attachment, sew with copy paper or tracing paper placed on top of the flat bed attachment so the fabric moves smoothly.

If the paper is positioned so that it does not cover the needle plate, the paper will not be sewn together with the fabric.

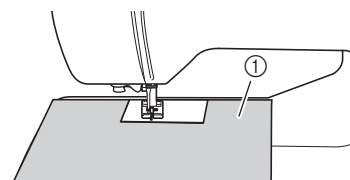

- ① Copy paper or tracing paper

■ Sewing Hook-and-Loop Fastener Tape

⚠ CAUTION

- If non-adhesive hook-and-loop fastener tape is sewn with a fine needle (65/9-75/11), the needle may break and cause injury.

IMPORTANT

- Adhesive backed hook-and-loop fastener tape is not designed for sewing. When glue adheres to the needle or the bobbin hook race, it may cause malfunction.

💡 Note

- Before starting to sew, baste the fabric and hook-and-loop fastener tape together.

Make sure that the needle passes through the hook-and-loop fastener tape by rotating the handwheel and lowering the needle into the hook-and-loop fastener tape before sewing. Sew the edge of the hook-and-loop fastener tape at a slow speed.

If the needle does not pass through the hook-and-loop fastener tape, replace the needle size with the needle for thick fabrics. (page 34)

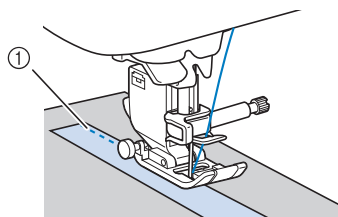

① Edge of the hook-and-loop fastener tape

Sewing Character/Decorative Stitches

Check the table below for the proper fabric/needle/thread combinations.

Fabric	When sewing on stretch fabrics, lightweight fabrics, or fabrics with coarse weaves, attach stabilizer on the wrong side of the fabric. If you do not wish to do so, place the fabric on a thin paper such as tracing paper.
	<p>① Fabric ② Stabilizer ③ Thin paper</p>
Thread	#50 - #60
Needle	With lightweight, regular, or stretch fabrics: the Ball point needle (golden colored) With heavyweight fabrics: home sewing machine needle 90/14
Presser foot	Advanced monogramming foot "N+". Using another presser foot may give inferior results.

Chapter 3 Various Stitches

Utility Stitches

CAUTION

- Before replacing the presser foot, be sure to touch  to lock all keys and buttons, otherwise injuries may occur if the "Start/Stop" button or any other button is pressed and the machine starts. For details on changing the presser foot, refer to "Replacing the Presser Foot" on page 48.

Straight Stitches

1 Select a stitch.

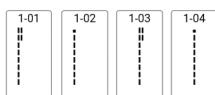



- * For details on stitch patterns, refer to "Stitch Chart" on page 273.

2 Start sewing.

- * For details, refer to "Basic Sewing" on page 51.
- * If necessary, sew reverse or reinforcement stitches at the beginning and end of the stitching. (page 55)

Changing the Needle Position

When you select straight stitches, you can use  and  in the [L/R Shift] display to change the position of the needle. Match the distance from the right edge of the presser foot to the needle with the L/R Shift, then align the edge of the presser foot with the edge of the fabric during sewing for an attractive finish.

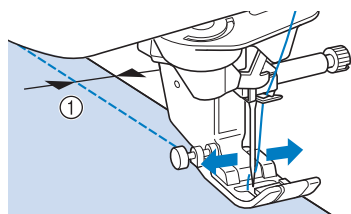

① L/R Shift

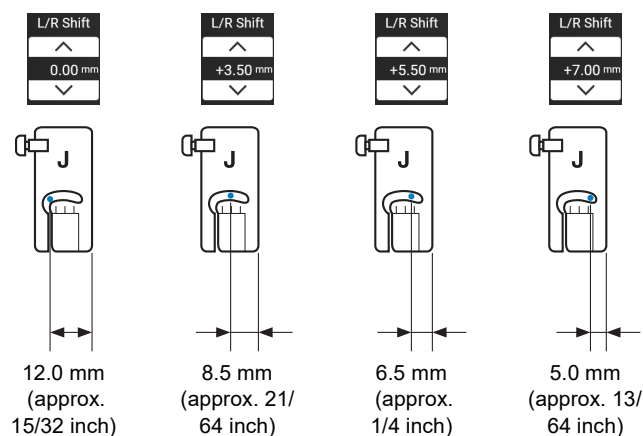

Memo

- Stitch Q-01 will not permit using the L/R Shift function.
- When [Width Control] in the settings screen is set to on, the needle position of a straight stitch can be changed with the sewing speed controller. Use the foot controller to operate the machine.

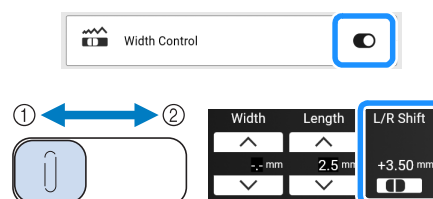

- Shift the stitch pattern to the left.
- Shift the stitch pattern to the right.

■ Aligning the Fabric with a Mark on the Needle Plate or Bobbin Cover (with Mark)

□ For stitches with a left needle position (L/R Shift: 0.00 mm)

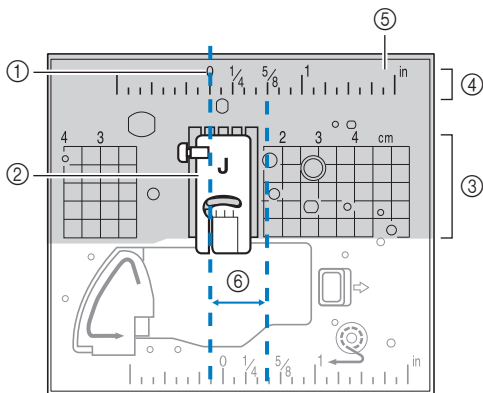

- ① Seam
- ② Presser foot
- ③ Centimeters
- ④ Inches
- ⑤ Needle plate
- ⑥ 5/8 inch (approx. 16 mm)

□ For stitches with a middle (center) needle position (L/R Shift: 3.50 mm)

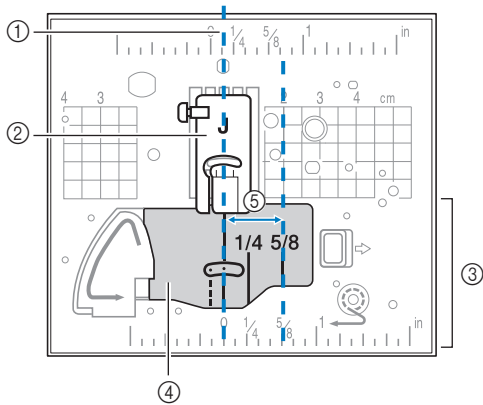

- ① Seam
- ② Presser foot
- ③ Inches
- ④ Bobbin cover (with mark)
- ⑤ 5/8 inch (approx. 16 mm)

■ Using the Straight Stitch Needle Plate and the Straight Stitch Foot

The straight stitch needle plate and the straight stitch foot can only be used for straight stitches (middle needle position stitches). Use the straight stitch needle plate and the straight stitch foot when sewing thin fabrics or when sewing small pieces which tend to sink into the hole of the regular needle plate during sewing.



⚠ CAUTION

- Always use the straight stitch foot in combination with the straight stitch needle plate. Otherwise, the needle may break and cause injury.

1 Turn off the machine and remove the needle plate.

- * For details, refer to steps 1 through 6 of "Cleaning the Race" on page 255.

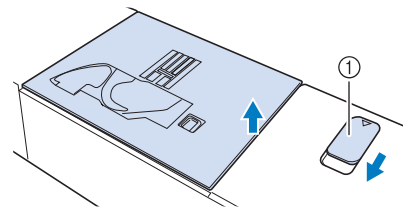

- ① Slide toward you.
- The needle plate opens.

2 Insert the tabs on the straight stitch needle plate into the notches in the machine.

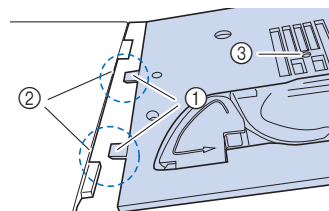

- ① Tabs
- ② Notches
- ③ Round hole

- 3** Press down on the right side of the straight stitch needle plate to secure it.

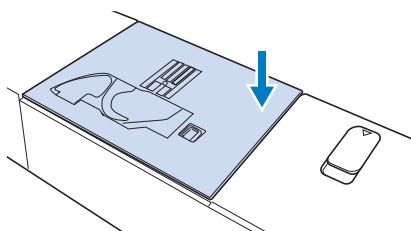

- 4** If necessary, attach the flat bed attachment.
- 5** Insert needle and attach the straight stitch foot. (page 36, page 48)
- 6** Select any of the straight stitches.

Memo

- When the straight stitch needle plate is attached on the machine, only stitch patterns that allow sewing with the straight stitch needle plate can be selected.
- When the straight stitch needle plate is on the machine, the needle will automatically move to the middle position.

Note

- Slowly rotate the handwheel toward you (counterclockwise) before sewing and make sure that the needle is not contacting the straight stitch foot and straight stitch needle plate.

- 7** Start sewing.

- * After sewing, make sure to turn off the machine and to remove the straight stitch needle plate and the straight stitch foot. Reinstall the regular needle plate and the zigzag foot “J”.

Memo

- The small opening on the foot provides support for the fabric as the needle travels through the fabric.

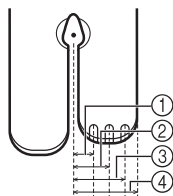

- ① 2.25 mm (approx. 1/8 inch)
- ② 4.25 mm (approx. 3/16 inch)
- ③ 6.25 mm (approx. 1/4 inch)
- ④ 8.5 mm (approx. 5/16 inch)

Zigzag Stitches

Zigzag stitches are useful for overcasting (page 84), appliqué (page 107), patchwork, and many other applications. For details on stitch patterns, refer to “Stitch Chart” on page 273.

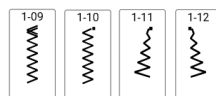

■ Using the Cord Guide Bobbin Cover

- 1** Remove the bobbin cover from the machine. (page 40)
- 2** Thread the gimp thread through the hole in the cord guide bobbin cover as shown in the illustration.

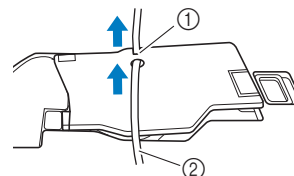

- ① Notch
- ② Gimp thread

- 3** Snap the cord guide bobbin cover into place, making sure there are no restrictions when feeding the thread.
- 4** Set the zigzag width from 2.0-2.5 mm (approx. 1/16 - 3/32 inch).
- 5** Attach advanced monogramming foot “N+”.
- 6** Position the fabric right side up on top of the cord and place the cord to the rear of the machine under the presser foot.

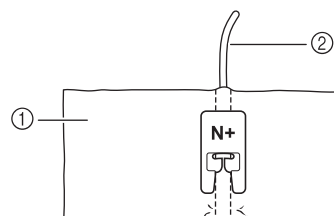

- ① Fabric (right side)
- ② Gimp thread

7 Start sewing to make a decorative finish.

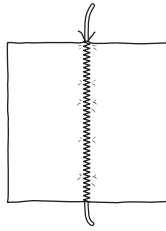

Overcasting

Sew overcasting stitches along the edges of cut fabric to prevent them from fraying. For details on stitch patterns, refer to “Stitch Chart” on page 273.

Using Overcasting Foot “G”

1 Select a stitch and attach the overcasting foot “G”.

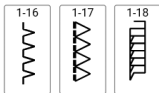

CAUTION

- When using overcasting foot “G”, be sure to select a stitch that can be used with overcasting foot “G”. If you sew with the incorrect stitch, the needle may strike the presser foot and break, and may cause injury.

2 Lower the presser foot so that the presser foot guide is set flush against the edge of the fabric.

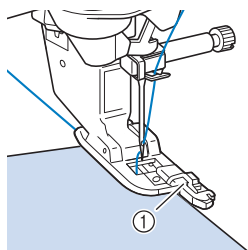

① Guide

3 Rotate the handwheel toward you (counterclockwise). Check that the needle does not touch the presser foot.

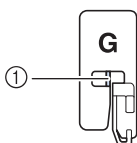

① The needle should not touch the center bar

4 Sew along the presser foot guide.

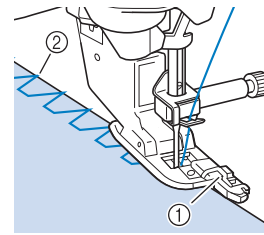

- ① Guide
- ② Needle drop point

5 Press the “Start/Stop” button to stop sewing when you are finished, and raise the presser foot and needle to remove the fabric by pulling it back.

IMPORTANT

- Be sure to pull the fabric backward after finished sewing. If you pull the fabric toward side or forward, the presser foot pin may be damaged.
- If thread is tangled on the presser foot, remove the entangled thread, and then raise the presser foot lever to remove the presser foot. If the presser foot is raised while entangled with thread, the presser foot may be damaged.

Using Zigzag Foot “J”

1 Select a stitch and attach zigzag foot “J”.

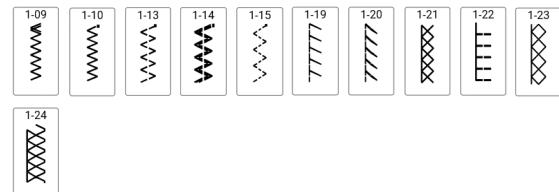

2 Sew with the needle dropping slightly off the edge of the fabric.

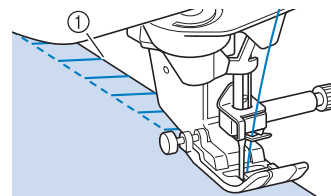

① Needle drop point

Blind Hem Stitches

Secure the bottoms of skirts and pants with a blind hem.

Memo

- When the size of cylindrical pieces is too small to slide onto the arm or the length is too short, the fabric will not feed and desired results may not be achieved.

1 Turn the skirt or pants wrong side out.

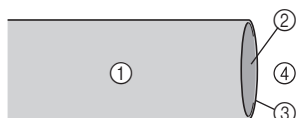

- ① Wrong side of fabric
- ② Right side of fabric
- ③ Edge of fabric
- ④ Bottom side

2 Fold the fabric along the desired edge of the hem, and press.

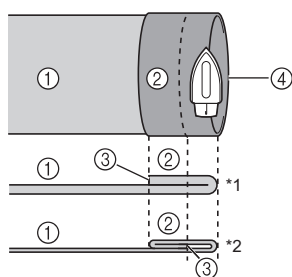

- ① Wrong side of fabric
- ② Right side of Fabric
- ③ Edge of fabric
- ④ Desired edge of hem
- *1 Thick fabric
- *2 Normal fabric

3 Use a chalk pencil to mark on the fabric about 5 mm (approx. 3/16 inch) from the edge of the fabric, and then baste it.

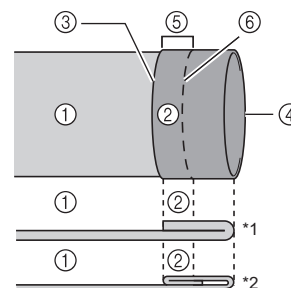

- ① Wrong side of fabric
- ② Right side of fabric
- ③ Edge of fabric
- ④ Desired edge of hem
- ⑤ 5 mm (approx. 3/16 inch)
- ⑥ Basting
- *1 Thick fabric
- *2 Normal fabric

4 Fold back the fabric inside along the basting.

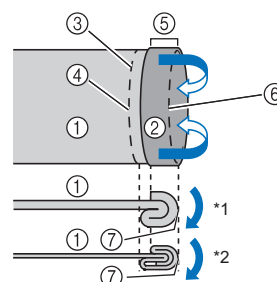

- ① Wrong side of fabric
- ② Right side of fabric
- ③ Edge of fabric
- ④ Desired edge of hem
- ⑤ 5 mm (approx. 3/16 inch)
- ⑥ Basting
- ⑦ Basting point
- *1 Thick fabric
- *2 Normal fabric

5 Unfold the edge of fabric, and position the fabric with the wrong side facing up.

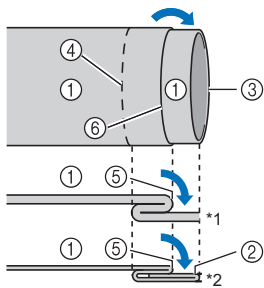

- ① Wrong side of fabric
- ② Right side of fabric
- ③ Edge of fabric
- ④ Desired edge of hem
- ⑤ Basting point
- ⑥ Basting
- *1 Thick fabric
- *2 Normal fabric

6 Attach blind stitch foot “R”.

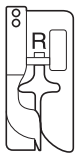

7 Select a stitch.

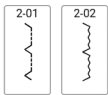

8 Remove the flat bed attachment to use the free arm.

9 Slide the item that you wish to sew onto the free arm and make sure that the fabric feeds correctly.

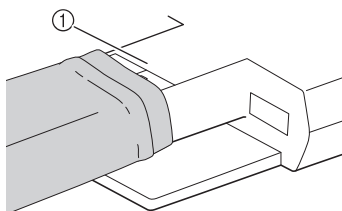

- ① Free arm

10 Position the fabric with the edge of the folded hem against the guide of the presser foot, and then lower the presser foot lever.

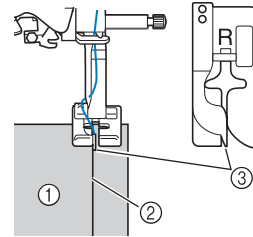

- ① Wrong side of fabric
- ② Fold of hem
- ③ Guide

11 Slowly turn the handwheel toward you and check that the needle slightly catches the fold of the hem.

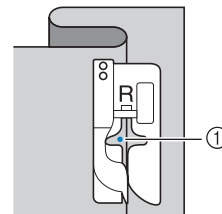

- ① Needle drop point

When you change the needle drop point, raise the needle, and then change the stitch width. (The stitch width setting is in neither millimeters nor inches.)

Width	Length	L/R Shift	Tension
00	2.0 mm	-.mm	4.0 III

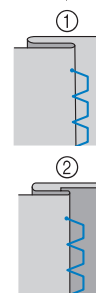
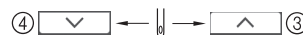

- ① Thick fabric
- ② Normal fabric
- ③ Touch to move the needle drop point to the right, if the needle catches too much of the fold.
- ④ Touch to move the needle drop point to the left, if the needle does not catch the fold.

Memo

- Blind hem stitches cannot be sewn if the left needle drop point does not catch the fold. If the needle catches too much of the fold, the fabric cannot be unfolded and the seam appearing on the right side of the fabric will be very large, leaving an unattractive finish.

12 Sew with the fold of the hem against the presser foot guide.

- * We recommend to stitch reinforcement stitches at the beginning and end of the hem.

13 Press the “Start/Stop” button to stop sewing when you are finished, and raise the presser foot and needle to pull the fabric under the presser foot towards the back of the machine.

IMPORTANT

- Be sure to pull the fabric towards the back of the machine after sewing. If you pull the fabric toward side or forward, the presser foot may be damaged.

14 Remove the basting stitching and reverse the fabric.

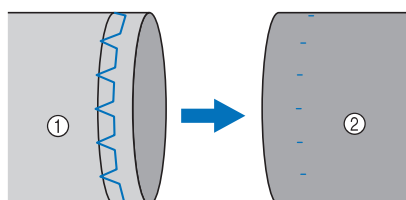

- ① Wrong side of fabric
- ② Right side of fabric

One-Step Buttonholes

Note

- For details on projecting buttonhole stitches and guidelines, refer to the following.
 - “Projecting/Editing the Stitch Pattern with the Projector” on page 70
 - “Buttonhole Guidelines” on page 68

With one-step buttonholes, you can make buttonholes appropriate to the size of your button.

One-step buttonholes are sewn from the front of the presser foot to the back, as shown below.

Memo

- For details on stitch patterns, refer to “Stitch Chart” on page 273.

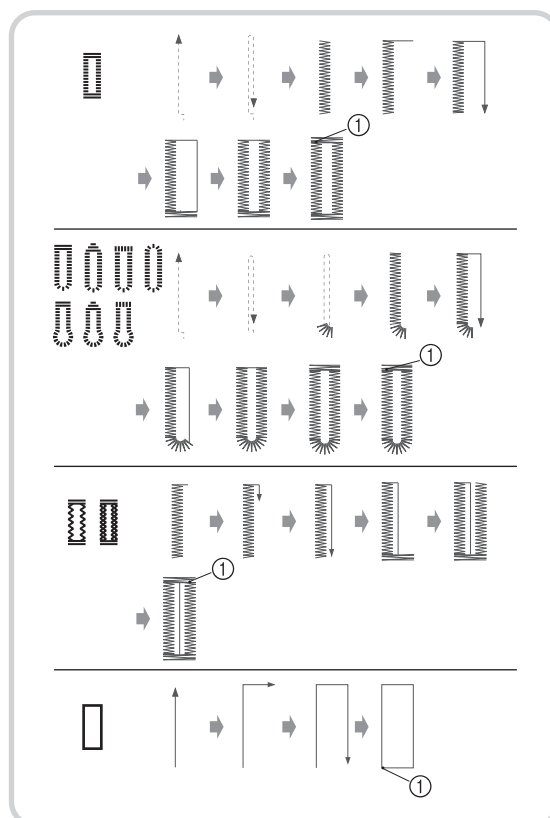

- ① Reinforcement stitching

1 Select a buttonhole stitch, and attach buttonhole foot “A+”.

Position the upper thread under the presser foot by guiding thread through the hole in the presser foot before attaching the buttonhole foot “A+”.

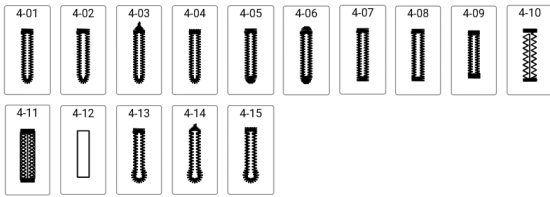

IMPORTANT

- When attaching and removing buttonhole foot “A+”, do not apply excessive force to the presser foot, otherwise it may be damaged. In addition, be careful not to hit the needle when attaching and removing buttonhole foot “A+”.

Note

- Before attaching the presser foot, check that there is enough thread in the bobbin.
- Sew trial stitches on fabric that is the same as that used in your project, referring to “Fabric/Thread/Needle Combinations” on page 34.
- The built-in camera detects the position of buttonhole foot “A+”. Do not touch the camera. (Refer to “Names of Machine Parts” on page 13.)
- Do not peel the “A+” sticker off buttonhole foot “A+” or cover the sticker with the upper thread, etc., otherwise the camera cannot detect the presser foot or buttonholes cannot be sewn.
- If the fabric does not feed correctly, such as when sewing stretchy fabrics, install the buttonhole foot stabilizer. (page 90)

2 Mark the position and length of the buttonhole on the fabric.

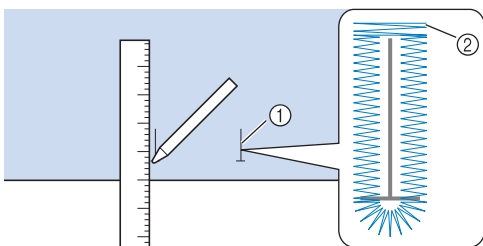

- ① Marks on fabric
- ② Buttonhole sewing

Memo

- The maximum buttonhole length is about 47 mm (approx. 1-3/4 inches) (diameter + thickness of the button).

3 Pull out the button holder plate on the presser foot, and insert the button that will be put through the buttonhole. Then tighten the button holder plate around the button.

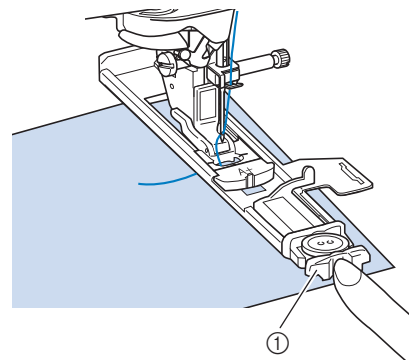

- ① Button holder plate

Memo

- The size of the buttonhole is determined by the size of the button in the button holder plate. If the button does not fit in the button holder plate, refer to page 89.

4 Align the presser foot with the mark on the fabric, and lower the presser foot.

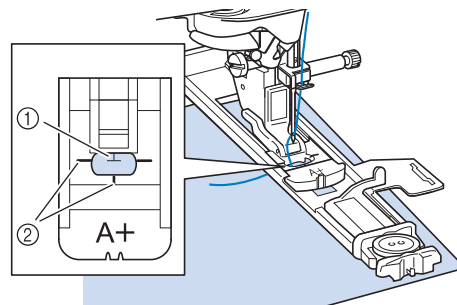

- ① Mark on the fabric
- ② Marks on the presser foot

Note

- After lowering the presser foot, make sure that there is no gap in ①.

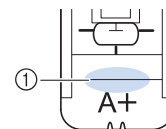

5 Gently hold the end of the upper thread, and then start sewing.

- * Feed the fabric carefully by hand while the buttonhole is sewn.

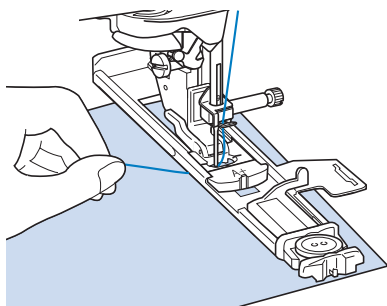

→ Once sewing is completed, the machine automatically sews reinforcement stitches, and then stops.

6 Press (Thread cutter button) once. Raise the presser foot, and then remove the fabric.

Memo

- When using scissors to cut the threads, press  (Needle position button) to raise the needle, raise the presser foot, and then pull out the fabric before cutting the threads.

7 Insert a pin along the inside of one of the bar tacks, and then insert the seam ripper into the center of the buttonhole and cut towards the pin.

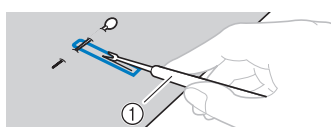

① Seam ripper

CAUTION

- When using the seam ripper to open the buttonhole, do not put your hand or finger in the path of the ripper. The ripper may slip and cause injury.

Memo

- For keyhole buttonholes, use the eyelet punch to make a hole in the rounded end of the buttonhole, and then use the seam ripper to cut open the buttonhole.

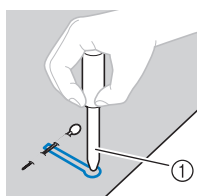

① Eyelet punch

Odd Shaped Buttons/Buttons that Do Not Fit into the Button Holder Plate

Add the button diameter and thickness together, and then set the button holder plate at the calculated value.

The distance between the long markings on the presser foot scale is 5 mm (approx. 3/16 inch).

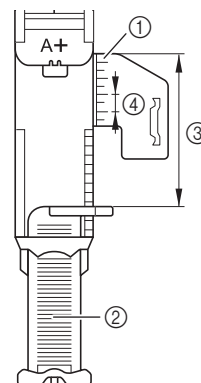

- ① Presser foot scale
- ② Button holder plate
- ③ Completed measurement of diameter + thickness
- ④ 5 mm (approx. 3/16 inch)

Example: For a button with a diameter of 15 mm (approx. 9/16 inch) and thickness of 10 mm (approx. 3/8 inch), align the scale with 25 mm (approx. 1 inch)

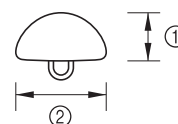

- ① 10 mm (approx. 3/8 inch)
- ② 15 mm (approx. 9/16 inch)

Setting the Slit Length

The calculated value can also be set in the screen instead of setting the button holder plate.

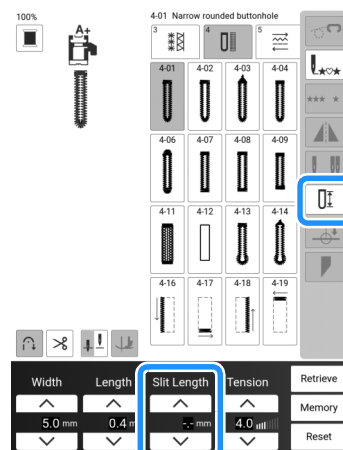

Memo

- Option: turn on projector make adjustment using dual purpose stylus. (page 70)

■ Fabric Cannot Be Correctly Fed

If the fabric does not feed (for example, because it is too thick), first increase the stitch length setting. If the fabric still does not feed correctly, such as when sewing thick fabrics or stretch fabrics, install the buttonhole foot stabilizer, and then feed the fabric between the buttonhole foot stabilizer and buttonhole foot "A+". Attach the buttonhole foot stabilizer to buttonhole foot "A+" before attaching buttonhole foot "A+" to the presser foot holder.

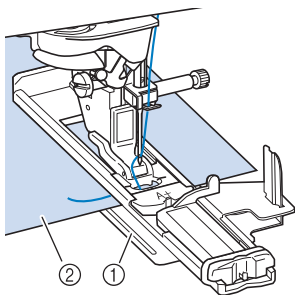

- ① Buttonhole foot stabilizer
- ② Fabric

■ Sewing Thick Fabrics

Place a piece of folded fabric or cardboard beside the fabric being sewn to level the buttonhole foot and allow for easier and even feeding.

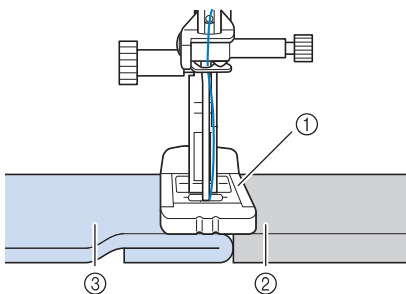

- ① Presser foot
- ② Thick paper
- ③ Fabric

■ Sewing Stretch Fabrics

When sewing on stretch fabric, sew the buttonhole stitches over a gimp thread.

Note

- Attach stabilizer material to the back of stretch fabrics to prevent them from stretching.

- 1** Hook the gimp thread onto the back of presser foot "A+". Insert the ends into the grooves of the presser foot, and then temporarily tie them there.

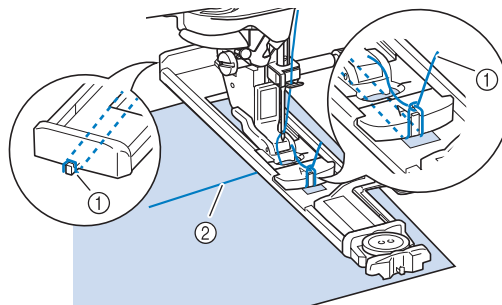

- ① Gimp thread
- ② Upper thread

- 2** Select a stitch and start sewing.

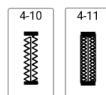

Memo

- Adjust the stitch width to the thickness of the gimp thread.

- 3** Once sewing is completed, gently pull the gimp thread to remove any slack, and trim off any excess.

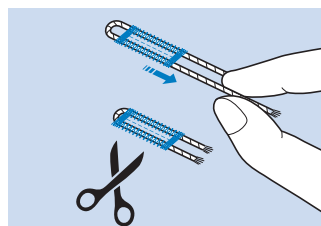

Four-Step Buttonholes

You can sew any desired length for the buttonhole when using 4-step buttonholes.

Note

- When changing the stitch settings, make sure that all stitch settings are changed to match.

Four-step buttonholes are sewn as shown below.

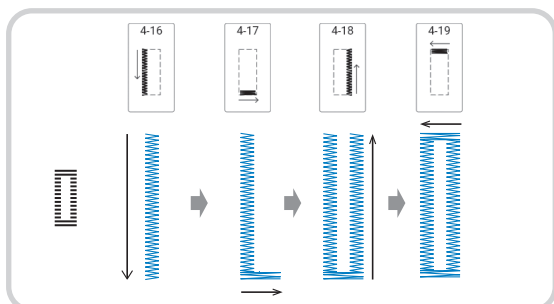

- 1 Mark the position and length of the buttonhole on the fabric.

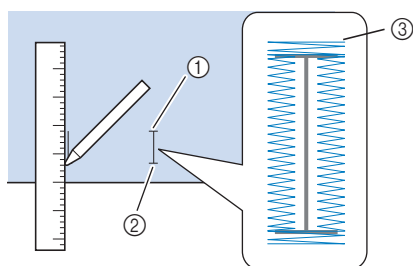

- ① Starting point
- ② End point
- ③ Buttonhole sewing

- 2 Attach advanced monogramming foot

“N+”, and select stitch  to sew the left side of the buttonhole.

- 3 Press the “Start/Stop” button to start sewing.
- 4 Sew the desired length for the buttonhole and press the “Start/Stop” button again.

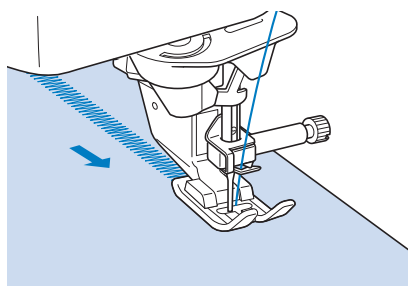

- 5 Select stitch  to sew the bar tack and press the “Start/Stop” button.

→ The machine will automatically stop after sewing the bar tack.

- 6 Select stitch  to sew the right side of the buttonhole, and press the “Start/Stop” button to begin sewing.

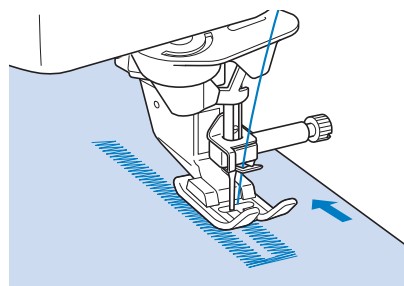

- 7 Sew the right side of the buttonhole and press the “Start/Stop” button again.

* Sew the right side of the buttonhole the same length as the left.

- 8 Select stitch  to sew the bar tack and then press the “Start/Stop” button.

→ The machine will automatically sew off the bar tack tie and stop when the bar tack is complete.

- 9 Raise the presser foot and remove the fabric.

- 10 Follow step 7 of “One-Step Buttonholes” on page 87 to open the buttonhole.

Button Sewing

Buttons with 2 or 4 holes can be attached, using the machine.

Note

- Do not use the automatic thread cutting function when sewing buttons. Otherwise, you will lose the thread ends.

1 Select .

→ The feed dogs are lowered automatically.

2 Raise the presser foot.

3 Attach button fitting foot “M”, slide the button along the metal plate and into the presser foot, and lower the presser foot.

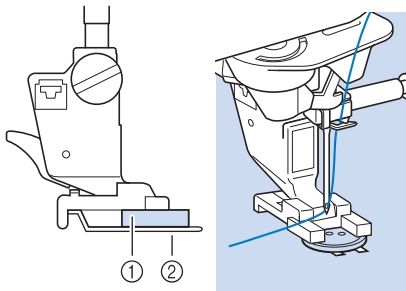

- ① Button
- ② Metal plate

4 Rotate the handwheel toward you (counterclockwise) to check that the needle goes into each hole correctly.

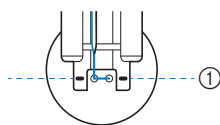

- ① Align the holes of the button with the marks on button fitting foot “M”.
- * If the needle does not reach the holes on the left side, adjust the stitch width.

5 Gently hold the end of the upper thread and start sewing.

- The machine stops automatically when sewing is finished.
- * To attach the button more securely, repeat the process.

IMPORTANT

- Make sure the needle does not strike the button during sewing.

6 From the wrong side of the fabric, pull the end of the bobbin thread to pull the upper thread through to the wrong side of the fabric. Tie the two thread ends together then cut the threads.

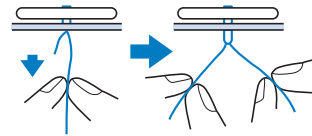

■ Attaching 4-Hole Buttons

Sew the two holes closest to you. Then raise the presser foot and move the fabric so that the needle goes into the next two holes, and sew them in the same way.

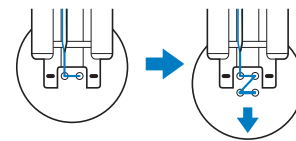

■ Attaching a Shank to the Button

1 Pull the shank lever toward you before sewing.

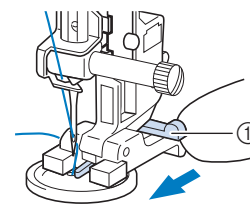

- ① Shank lever

2 After sewing is finished, cut the upper thread with plenty of excess, wind it around the thread between the button and the fabric, and then tie it to the upper thread from the beginning of the stitching.

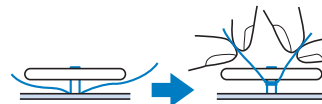

3 Tie the ends of the bobbin thread from the beginning and end of sewing together on the wrong side of the fabric.

4 Cut off any excess thread.

Bar Tacks

Use bar tacks to reinforce areas that will be subject to strain, such as pocket corners.

1 Select



2 Attach buttonhole foot “A+” and set the scale to the length of the bar tack you wish to sew.

Position the upper thread under the presser foot by guiding thread through the hole in the presser foot before attaching the buttonhole foot “A+”.

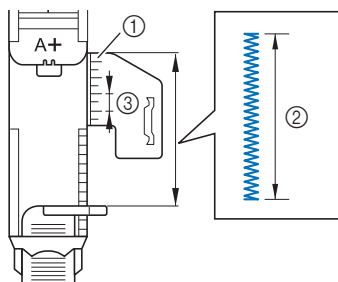

- ① Presser foot scale
- ② Completed length measurement
- ③ 5 mm (approx. 3/16 inch)

Memo

- Instead of setting the bar tack length with the buttonhole foot, it can be set on the screen. (page 89)

3 Set the fabric so that the pocket moves toward you during sewing.

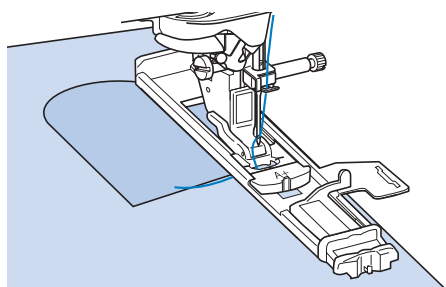

Note

- After lowering the presser foot, make sure that there is no gap in ①.

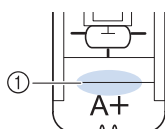

4 Check the first needle drop point and lower the presser foot.

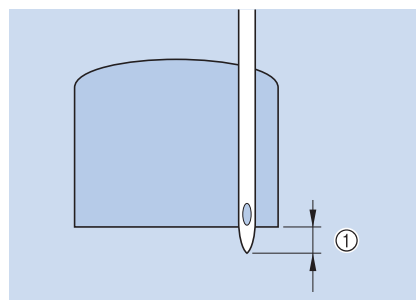

- ① 2 mm (approx. 1/16 inch)

5 Gently hold the end of the upper thread and begin sewing.

→ When sewing is completed, the machine will sew reinforcement stitches and stop automatically.

Memo

- If the fabric does not feed, for example, because it is too thick, refer to “Sewing Thick Fabrics” on page 90.

Darning

Use darning stitches for mending and other applications.

Darning is performed by sewing from the front of the presser foot to the back as shown below.

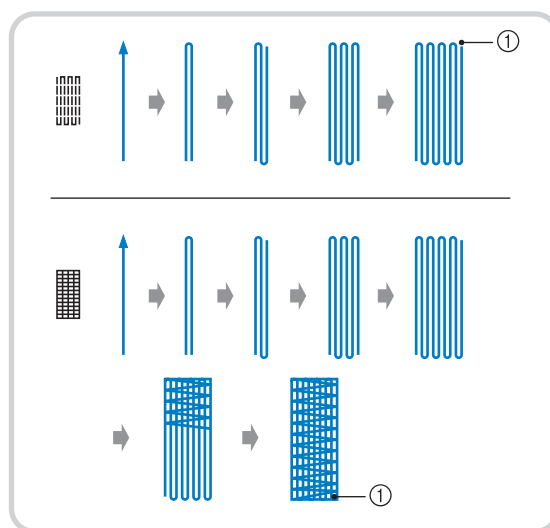

- ① Reinforcement stitches

1 Select a stitch, and attach buttonhole foot “A+”.

Position the upper thread under the presser foot by guiding thread through the hole in the presser foot before attaching the buttonhole foot “A+”.

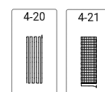

2 Set the scale to the desired length of the darning.

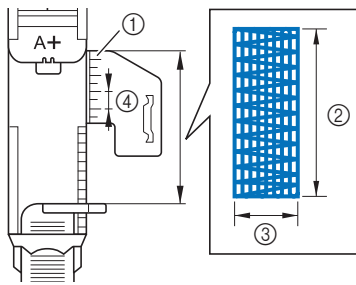

- ① Presser foot scale
- ② Completed length measurement
- ③ Width 7 mm (approx. 1/4 inch)
- ④ 5 mm (approx. 3/16 inch)

Memo

- Instead of setting the darning length with the buttonhole foot, it can be set on the screen. (page 89)

3 Check that the needle drops at the desired position and lower the presser foot, making sure the upper thread passes underneath the buttonhole foot.

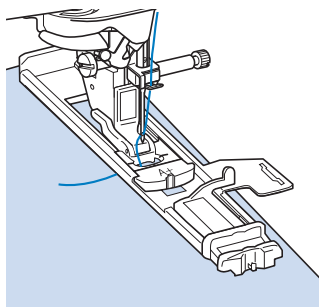

Note

- After lowering the presser foot, make sure that there is no gap in ①.

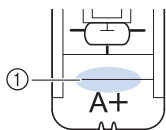



4 Gently hold the end of the upper thread, and then press the “Start/Stop” button to start the machine.

- Once sewing is completed, the machine automatically sews reinforcement stitches, and then stops.

Eyelet

Use this stitch for making belt holes and other similar applications.

- 1** Select  or .
- 2** If selecting , adjust either the stitch width or the stitch length to choose the size of the eyelet. (page 61)
- 3** Attach advanced monogramming foot “N+”, then rotate the handwheel toward you (counterclockwise) to check the needle drop point.

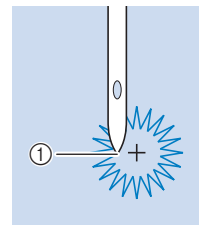

- ① Needle drop point

4 Lower the presser foot and start sewing.

- When sewing is finished, the machine sews reinforcement stitches and stops automatically.



Note

- If the stitch pattern comes out poorly, make adjustments by following “Making Adjustments” on page 105.

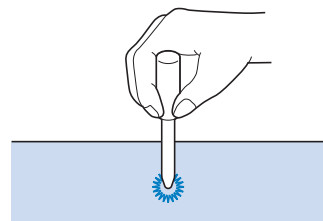
5 Use the eyelet punch to make a hole in the center of the stitching.



Basting

- 1 Select  and attach zigzag foot “J”.
- 2 Before sewing, pull up the bobbin thread, align it with the upper thread, and then pull them to the back of the machine. (page 41)
 - * For clean stitching, hold these thread ends when starting to sew.
- 3 If desired, keep pressing  (Reverse stitch button) or  (Reinforcement stitch button) to sew 4 stitches of reinforcement stitches, then press “Start/Stop” button to continue sewing.
- 4 Sew while keeping the fabric straight.

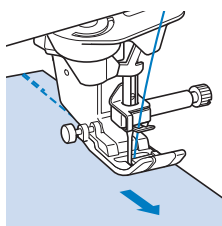

- 5 If desired, end the basting with reinforcement stitches.

■ Basting with the Stitch Regulator



The stitch regulator allows free-motion basting with a set stitch length. Refer to “Free-Motion Quilting/ Basting with the Stitch Regulator” on page 114.

■ Free-Motion Basting

When the feed dogs are lowered, basting can be sewn while freely moving the fabric.

- 1 Touch  and then select .

→ The presser foot is raised to the necessary height, and then the feed dogs are lowered for free motion sewing.

- 2 If desired, keep pressing  (Reverse stitch button) or  (Reinforcement stitch button) to sew 4 stitches of reinforcement stitches.

- 3 Press the “Start/Stop” button to start sewing. While the needle is raised, slide the fabric to the next sewing position to sew one stitch. Repeat this operation.

Memo

- If the side pedal of the multi-function foot controller is set to [Single Stitch], basting can be sewn by using the side pedal to sew each single stitch. (page 53)

- 4 If desired, end the basting with reinforcement stitches.

Zipper Insertion

■ Centered Zipper

Use for bags and other such applications.

- 1 Select .

Note

- Make sure you sew using the middle needle position.

- 2 Attach zigzag foot “J” and sew straight stitches up to the zipper opening. Change to a basting stitch (page 95) and sew to the top of the fabric.

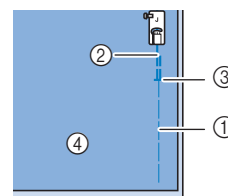

- ① Basting stitches
- ② Reverse stitches
- ③ End of zipper opening
- ④ Wrong side

- 3 Press the seam allowance open and attach the zipper with a basting stitch in the middle of each side of the zipper tape.

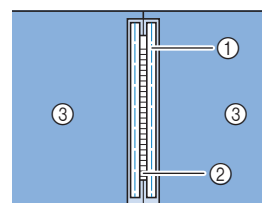

- ① Basting stitches
- ② Zipper
- ③ Wrong side

4 Remove zigzag foot “J”. Align the right side of the pin in zipper foot “I” with the presser foot holder, and attach the zipper foot.

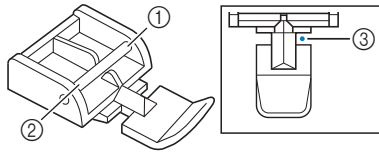

- ① Right
- ② Left
- ③ Needle drop point

Note

- When using zipper foot “I”, make sure the straight stitch, middle needle position is selected. Rotate the handwheel toward you (counterclockwise) to make sure the needle does not strike the presser foot.

5 Topstitch 7 to 10 mm (approx. 1/4 to 3/8 inch) from the seamed edge of the fabric, then remove the basting.

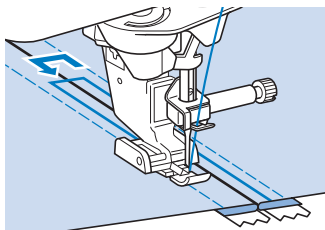

CAUTION

- Make sure the needle does not strike the zipper during sewing. If the needle strikes the zipper, the needle may break, leading to injury.

Inserting a Side Zipper

Use for side zippers in skirts or dresses.

1 Select .

Note

- Make sure you sew using the middle needle position.

2 Attach zigzag foot “J” and sew straight stitches up to the zipper opening. Change to a basting stitch and sew to the top of the fabric.

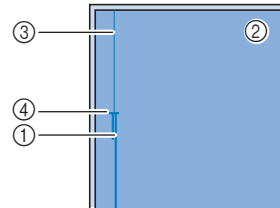

- ① Reverse stitches
- ② Wrong side of fabric
- ③ Basting stitches
- ④ End of zipper opening

3 Press the seam allowance open and align the folded hem along the teeth of the zipper, while maintaining 3 mm (approx. 1/8 inch) of sewing space.

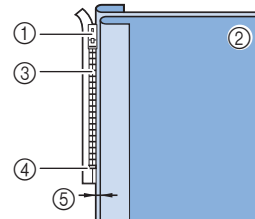

- ① Zipper pull tab
- ② Wrong side of fabric
- ③ Zipper teeth
- ④ End of zipper opening
- ⑤ 3 mm (approx. 1/8 inch)

4 Remove zigzag foot “J”.

5 Align the right side of the pin in zipper foot “I” with the presser foot holder, and attach the presser foot.

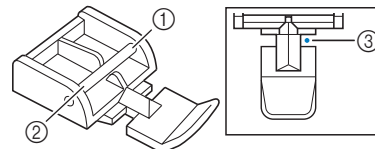

- ① Right
- ② Left
- ③ Needle drop point

Note

- When using zipper foot “I”, make sure the straight stitch, middle needle position is selected. Rotate the handwheel toward you (counterclockwise) to make sure the needle does not strike the presser foot.

6 Set the presser foot in the 3 mm (approx. 1/8 inch) margin.

- 7** Starting from the end of the zipper opening, sew to a point about 50 mm (approx. 2 inches) from the edge of the fabric, then stop the machine.
- 8** Pull down the zipper slider, then continue sewing to the edge of the fabric.

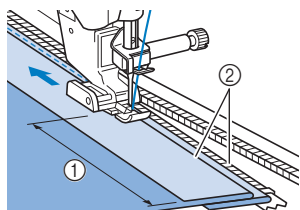

- ① About 5 cm (approx. 2 inches)
② 3 mm (approx. 1/8 inch)

CAUTION

- Make sure the needle does not strike the zipper during sewing. If the needle strikes the zipper, the needle may break, leading to injury.

- 9** Close the zipper, turn the fabric over, and sew a basting stitch.

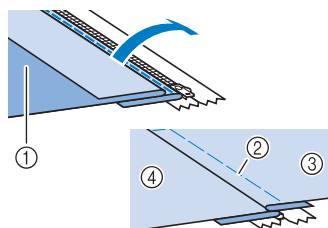

- ① Front of the skirt (wrong side of fabric)
② Basting stitches
③ Front of the skirt (right side of fabric)
④ Back of the skirt (right side of fabric)

- 10** Remove the presser foot, and reattach it so that the left side of the pin is attached to the presser foot holder.

- * When sewing the left side of the zipper, the needle should drop on the right side of the presser foot. When sewing the right side of the zipper, the needle should drop on the left side of the presser foot.

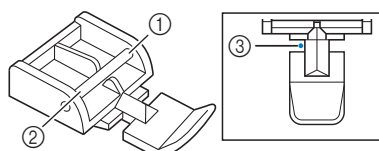

- ① Right
② Left
③ Needle drop point

- 11** Set the fabric so that the left edge of the presser foot touches the edge of the zipper teeth.

- 12** Sew reverse stitches at the end of the zipper, then continue sewing.
- 13** Stop sewing about 5 cm (approx. 2 inches) from the edge of the fabric, leave the needle in the fabric, and remove the basting stitches.
- 14** Open the zipper and sew the rest of the seam.

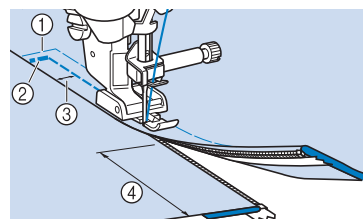

- ① Basting stitches
② Reverse stitches
③ 7 to 10 mm (approx. 1/4 inch to 3/8 inch)
④ About 5 cm (approx. 2 inches)

Stitch Tapering Function

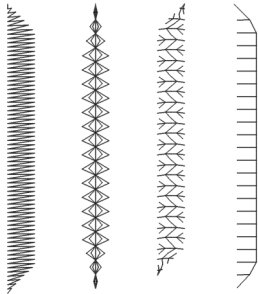

The angles of the start and end of stitch patterns can be changed. This is useful when sewing projects with sharply defined angles or decorative stitching, attaching appliqués, etc.



Use the method for finishing the stitch pattern, according to your needs.

- “Method 1: Begin Changing the Angle at the End of Sewing by Pressing the “Reverse Stitch” Button” on page 98
- “Method 2: Sewing a Specified Number of Stitch Patterns” on page 100
- “Method 3: Specifying the Sewing End Point with an End Point Sticker” on page 100

Note

- Using the same material and stitch pattern as your project, sew trial stitches to check the result. If necessary, attach a stabilizer material.
- If reinforcement stitches at the beginning and end of sewing are needed, use  (Reinforcement stitch button).  (Reverse stitch button) cannot be used for reinforcement stitching when stitch tapering function is on.

Method 1: Begin Changing the Angle at the End of Sewing by Pressing the “Reverse Stitch” Button

- 1 Touch [Utility Stitch], then , and then select a stitch pattern for stitch tapering.

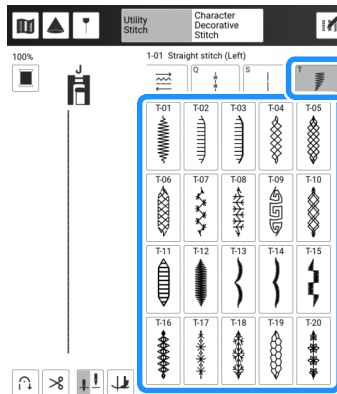

- 2 If necessary, change the stitch width and stitch length.

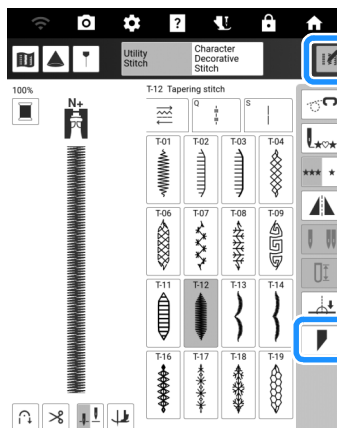

- 3 Touch , and then touch .



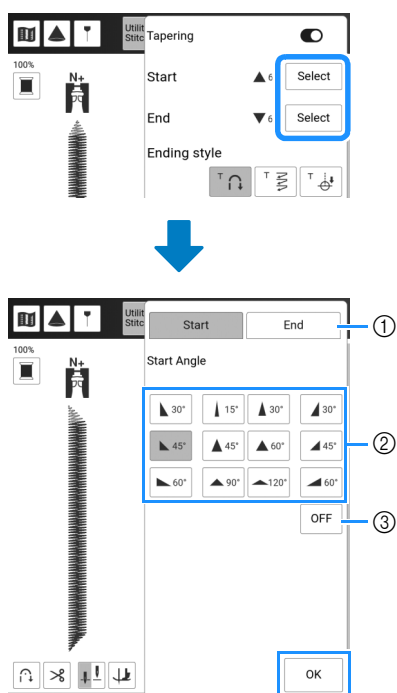

- 4** Touch [Select], select the angle settings for the start and end of sewing, and then touch [OK].

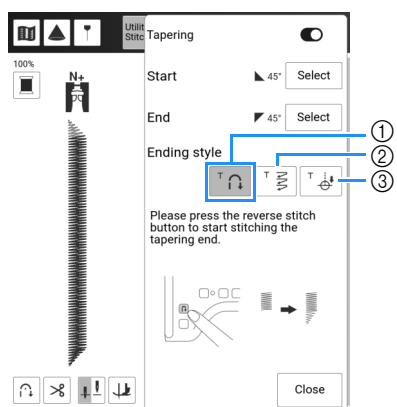

- ① Select the start or end of sewing.
- ② Select an angle.
- ③ Specify that the angle does not change.

- 5** Select the method for finishing sewing. For this example, since the angle at the end of sewing will begin changing when  (Reverse stitch button) is pressed, select .



- ① Press  (Reverse stitch button) for the angle at the end of sewing to start changing; the machine stops when sewing is finished.
- ② The machine stops when the specified number of stitch patterns have been sewn. The number of patterns that are specified includes the number of patterns used to change the angle. (page 100)
- ③ The machine stops at the position where the end point sticker is affixed. (page 100)

- 6** If necessary, use a chalk pencil to draw a line at the location to be sewn.

- 7** Start sewing.

- 8** After sewing the desired length, press

 (Reverse stitch button).

→ When  (Reverse stitch button) is pressed, the angle at the end of sewing begins to change, and the machine stops when sewing is finished.

Memo

- If you stop sewing at the point where end tapering should begin (either by pressing the “Start/Stop” button or by lifting your foot from the foot controller), press  (Reverse stitch button) and resume sewing by either pressing the “Start/Stop” button or pressing on the foot controller. End tapering will begin as soon as sewing resumes.

- 9** When finished sewing, set [Tapering] to off, and then touch [Close].

Method 2: Sewing a Specified Number of Stitch Patterns

With this method, the number of stitch patterns (including those used to change the angle) are specified. This allows stitch patterns of the same length to be repeatedly sewn.

- 1 Refer to steps 1 through 4 of “Method 1: Begin Changing the Angle at the End of Sewing by Pressing the “Reverse Stitch” Button” on page 98 to select the angle settings for the start and end of sewing.
- 2 Touch , and then specify the number of stitch patterns (including those used to change the angle).

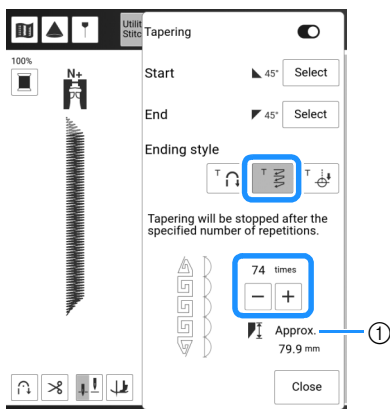

① Approximate length of the stitch pattern



Memo

- The number of stitch patterns used to change the angle depends on the pattern and angle. Perform trial sewing to check the result.

3 Start sewing.

→ The machine stops automatically when sewing is finished.

Memo

- To sew stitching in a square, select  for the start of sewing and  for the end of sewing, and then continue sewing the same stitch pattern, rotating the fabric 90° after sewing each line of stitching. The pivot setting is useful when changing the sewing direction. (page 72)

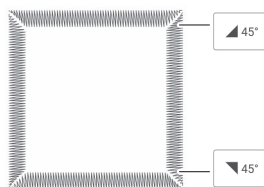

Method 3: Specifying the Sewing End Point with an End Point Sticker

Note

- For details on the procedure as well as precautions, refer to “Specifying the Sewing End Point” on page 75.

- 1 With a chalk pencil, mark the fabric with lines for sewing the stitch pattern and for the end of stitching.
- 2 Affix an end point sticker, avoiding the sewing area. Attach the end point sticker within 4 cm (approx. 1-1/2 inches) to the left or right of the chalkline where the end point for sewing has been drawn.

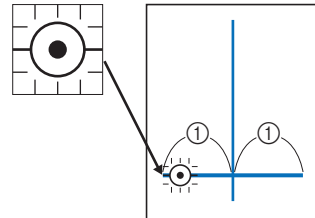

① 4 cm (Approx. 1-1/2 inches)

Memo

- If you cannot affix an end point sticker avoiding the sewing area, refer to “Temporary Stop Setting” on page 77.



3 Refer to steps 1 through 4 of “Method 1: Begin Changing the Angle at the End of Sewing by Pressing the “Reverse Stitch” Button” on page 98 to select the angle settings for the start and end of sewing.

4 Touch .

- * If the key appears in light gray, this function cannot be used with the selected stitch length.

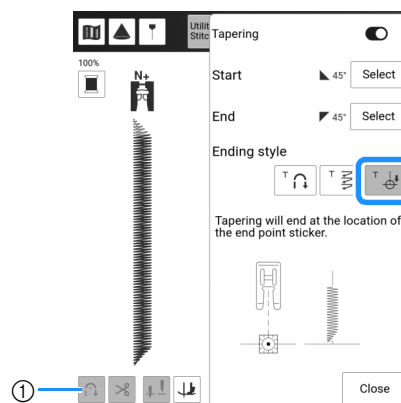

① Automatic reinforcement stitching function and automatic thread cutting function are not available.

5 Start sewing.

→ The machine stops automatically when sewing is finished.

6 Peel off the end point sticker.**■ Saving Settings**

Specified angles for start and end, finish tapering method, and stitch settings can be saved in machine's memory.

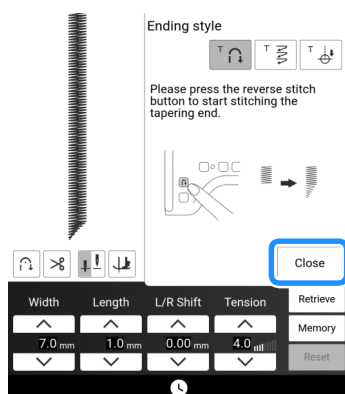
1 After setting the tapering function, touch [Close].**2 Touch [Memory].****■ Retrieving Saved Settings****1 Touch [Retrieve] to retrieve the saved setting after selecting pattern.****2 Touch the numbered key of the settings to be retrieved and then touch [Retrieve].**

* The settings cannot be retrieved if stitch tapering function is set to on.

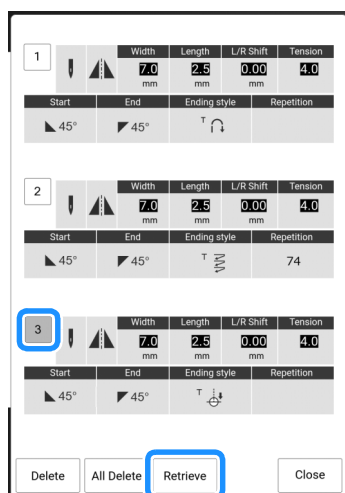
**📖 Memo**

- For more information on saving and recalling settings, refer to "Saving the Utility Stitch Settings" on page 63.

Couching

You can easily sew decorative effects using yarn.

⚠ CAUTION

- When using yarn, we recommend selecting yarn of weight 4 (MEDIUM). Medium yarn is often referred to as worsted weight, 20 knitted stitches per 10 cm, or 9-11 wraps per inch. The diameter of the yarn is approximately 2-3 mm (approx. 1/12-1/8 inch). If the yarn is extremely thin or thick, has an unusual shape (flat or furry), or more than 2 yarns, the best finishing results may not be achieved, or injuries or damage may result.

💡 Note

- Sew test stitches on the fabric before sewing on your project.
- We recommend using a stabilizer material when sewing stretch fabrics, lightweight fabrics, fabrics with a coarse weave, or fabrics which are prone to fabric shrinkage.

■ Prepare for Couching**1 Attach the spool stand to the machine.**

At this time, do not raise the telescopic thread guide shaft.

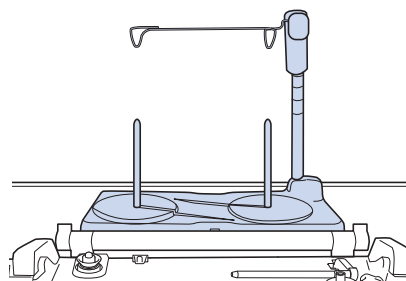

* Refer to "Assembling the Spool Stand" on page 45.

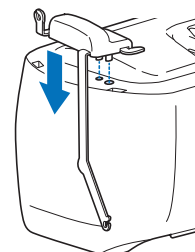
2 Insert the yarn guide into the slot on the top left of the machine.**3 Touch to lock all keys and buttons, and then raise the presser foot lever.**

4 Attach the compact dual feed to the machine without attaching the couching dual feed foot.

* Refer to "Attaching the Compact Dual Feed Foot" on page 49.



5 Pass the yarn through the telescopic thread guide and the yarn guide (①) to (②).

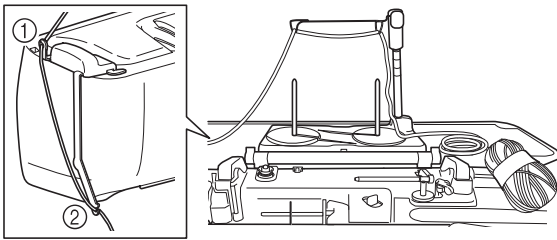

Note

- Make sure that the yarn does not become entangled as you work.

6 Thread the yarn through the couching dual feed foot. Pass the yarn through the loop in the yarn threader, and then pass the threader from top to bottom through the hole on the couching dual feed foot.

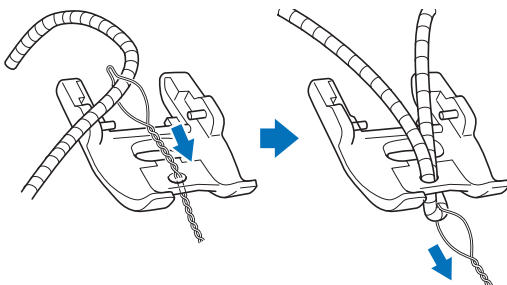

7 Attach the couching dual feed foot shown below to the compact dual feed.

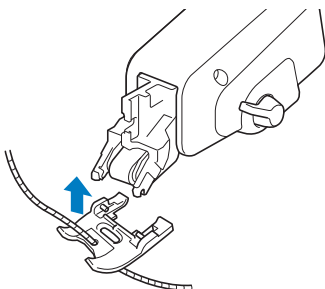

8 Pull out the yarn for about 10 cm (approx. 4 inches) to the back of the machine.

9 Touch  to unlock all keys and buttons.

10 Thread the machine with the upper thread.

Note

- Do not use the spool stand for upper thread. Otherwise thread may tangle with yarn.

Sewing Couching

1 Select .

2 Measure the width of the yarn and set the stitch width according to the width of the yarn.

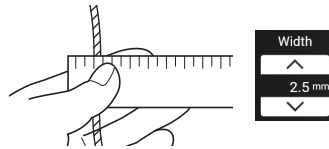

Note

- Make sure that there is enough width to wrap over the yarn.

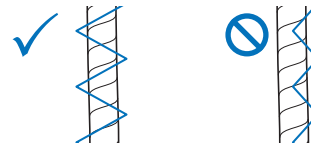

3 Rotate the handwheel to set the needle in the sewing start position. Start sewing on the right side of the yarn.

4 Make sure that the yarn passes straight through the channel in the back of the couching dual feed foot, and then lower the presser foot.

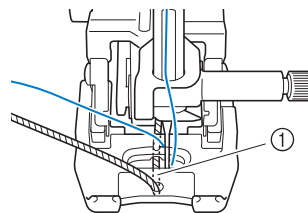

① Channel

Note

- Pull off an appropriate amount of yarn from the ball or skein so the yarn does not become taut.

5 Set the sewing speed to a medium speed.

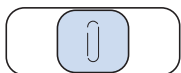

6 Press “Start/Stop” button to start sewing.

- * While lightly holding down the fabric with both hands, adjust the sewing direction.

Memo

- The multi-function foot controller can also be very useful for sharp angle sewing when set to single stitch sewing. (page 53)
- Pivoting is also useful when rotating fabric with both hands. (page 72)
- When guideline marker is set to on, it is easy to sew couching straight. (page 65)

Multi-directional Sewing

Use these stitch patterns to attach patches or emblems to pant legs, shirt sleeves, etc.

1 Remove the flat bed attachment to use the free arm. (page 78)

Memo

- Insert the tubular piece of fabric onto the free arm, and then sew in the order shown in the illustration.

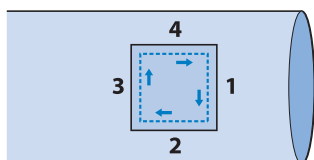

2 Touch , and then select a stitch

pattern. For this example, touch . And then, attach advanced monogramming foot “N+”.

3 Set the needle in the fabric at the sewing start point, and sew seam “1” as shown.

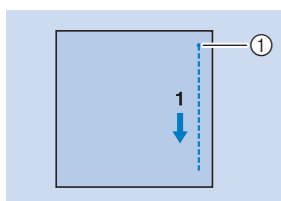

① Start Point

4 Select and sew seam “2” as shown.

- * The fabric will move sideways, guide the fabric by hand to keep sewing straight.

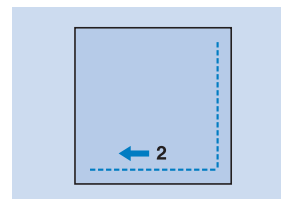

5 Select and sew seam “3” as shown.

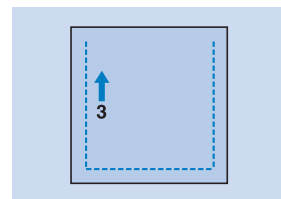

→ The fabric feeds forward while stitching backward.

6 Select and sew seam “4” as shown.

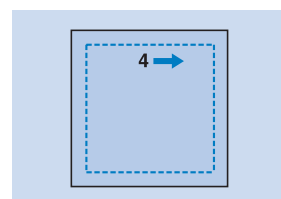

→ The seam will be connected to the starting point of seam 1.

Making Step Stitch Patterns

You can create a step effect, also called step stitch patterns. Touch to move the stitch pattern a distance equal to half of the stitch pattern's size to the left/right.

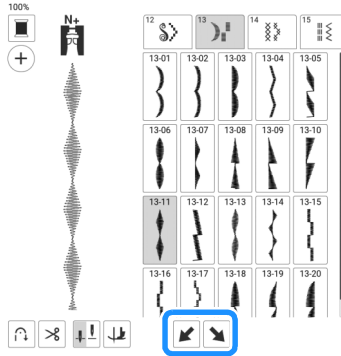

Example:



1 Select .

2 Touch , and then touch .

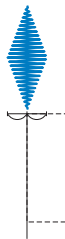

→ The next stitch pattern will move to the right.

3 Select again.

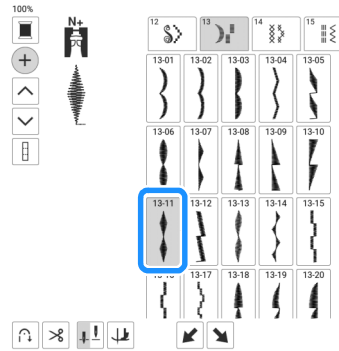

4 Touch .



→ The next stitch pattern will move to the left.

5 Touch , and then touch .

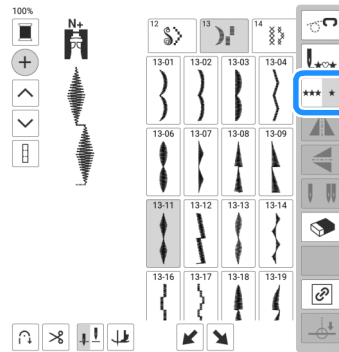

→ The entered stitch pattern is repeated.

Making Adjustments

If your sewing does not turn out well, sew trial stitches using the same conditions as the real sewing, and adjust the stitch pattern as explained below.

If the stitch pattern does not turn out well even after making adjustments based on the stitch pattern, make adjustments for each stitch pattern individually.

Memo

- This function is available for the following stitch patterns.

- All stitch patterns in

Character
Decorative
Stitch



and



in

Utility
Stitch



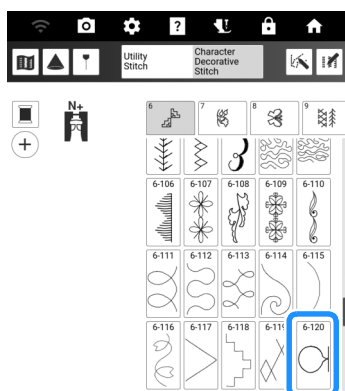

1 Touch  and select .

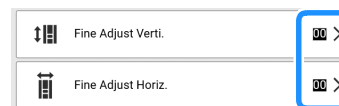
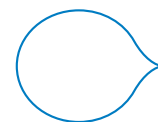

2 Attach advanced monogramming foot “N+” and sew the stitch pattern.

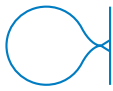
3 Compare the finished stitch pattern to the illustration of the correct stitch pattern below. Touch , and then adjust the stitch pattern with the [Fine Adjust Vert.] or [Fine Adjust Horiz.] displays.



Problem	Solution
<p>The stitch pattern is bunched.</p> 	<p>Touch to increase the number in the [Fine Adjust Vert.] display. The stitch pattern will lengthen.</p>
<p>The stitch pattern has gaps.</p> 	<p>Touch to decrease the number in the [Fine Adjust Vert.] display. The stitch pattern will shorten.</p>
<p>The stitch pattern is skewed to the left.</p> 	<p>Touch to increase the number in the [Fine Adjust Horiz.] display. The stitch pattern will slide to the right.</p>
<p>The stitch pattern is skewed to the right.</p> 	<p>Touch to decrease the number in the [Fine Adjust Horiz.] display. The stitch pattern will slide to the left.</p>

4 Sew the stitch pattern again.

- * Adjust until the stitch pattern comes out correctly.

Memo

- You can sew with the setting screen on the display.



Sewing with a Twin Needle

With the twin needle, you can sew two parallel lines of the same stitch with two different threads. Both upper threads should have the same thickness and quality.

⚠ CAUTION

- When using the twin needle, it is recommended to use zigzag foot “J”. Otherwise, the needle may break and cause injury.
- Before changing the needle or threading the machine, be sure to touch  on the LCD Screen to lock all keys and buttons, otherwise injuries may occur if the “Start/Stop” button or any other button is pressed and the machine starts sewing.

IMPORTANT

- Twin needle (size 2/11) is recommended for this machine. Contact your authorized Brother dealer for replacement needles.
-  (Automatic threading button) cannot be used. Manually thread the twin needle from front to back.
- Using  (Automatic threading button) may result in damage to the machine.

Note

- When the twin needle is used, bunched stitches may occur depending on the types of fabric and thread that are used. Use advanced monogramming foot “N+” or attach stabilizer material.

1 Touch and then install the twin needle (“Changing the Needle” on page 36).

- * If the message [OK to automatically lower the presser foot?] appears on the LCD screen, touch to continue.

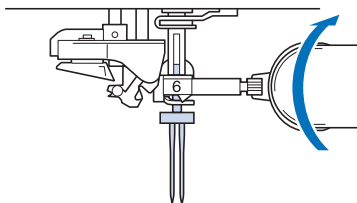

2 Pass the first upper thread according to steps 1 through 8 of “Upper Threading” on page 42.

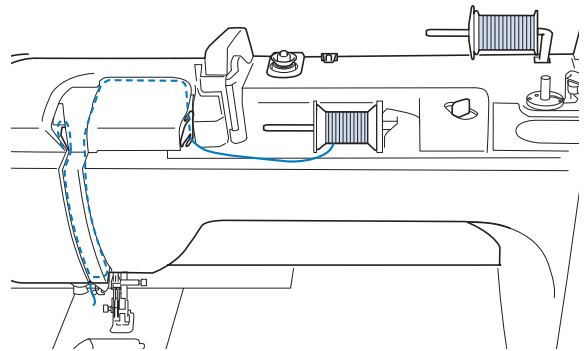

3 Pass the thread through the needle bar thread guide, then thread the needle on the left side manually.

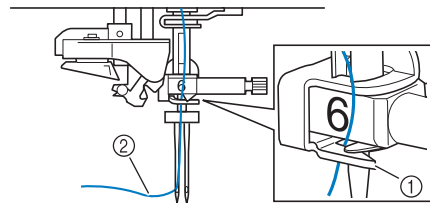

- ① Needle bar thread guide
- ② First upper thread

4 Set the supplemental spool pin in the “up” position and then place the additional spool of thread, so that the thread unwinds to the front from the bottom.

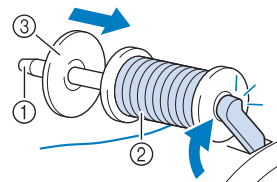

- ① Supplemental spool pin
- ② Thread spool
- ③ Spool cap

- 5** Thread the machine as shown in the illustration.

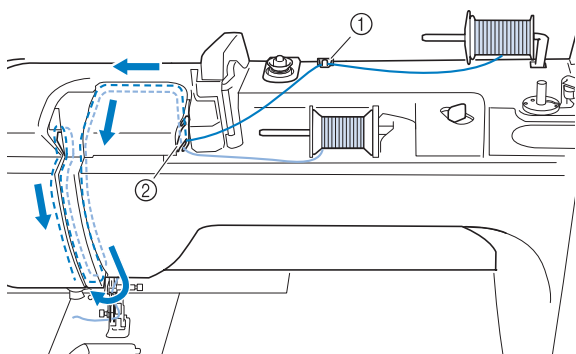

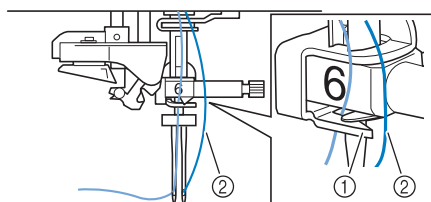

- ① Thread guide
② Thread guide plate

- 6** Without passing the thread through the needle bar thread guide, thread the needle on the right side manually.



- ① Needle bar thread guide
② Additional upper thread

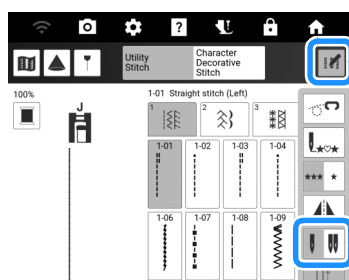

- 7** Touch  to unlock all keys and buttons.

- 8** Touch , and then touch  to select the twin needle mode.



→ Twin needle mode is set. Only stitch patterns that allow twin needle sewing can be selected.

Memo

- If the  key is light gray after selecting the stitch, the selected stitch cannot be sewn in the twin needle mode. In addition, the twin needle cannot be used with functions that cannot be set to twin needle mode (functions where  does not appear).

CAUTION

- Be sure to set the twin needle mode when using the twin needle. Using the twin needle while the machine is in single needle mode could cause the needle to break and cause injury.

- 9** Select a stitch pattern.

- Refer to "Stitch Chart" on page 273 for stitch patterns that can use a twin needle.

- 10** Start sewing.

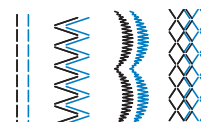

Memo

- To change direction when sewing with the twin needle, raise the needle from the fabric, raise the presser foot lever, and then turn the fabric.

Sewing Technique

■ Appliqué

- 1** Use two-sided stabilizer material to secure the appliqué piece to the base fabric.

- 2** Select a stitch.

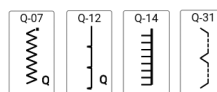

- For details on stitch patterns, refer to "Stitch Chart" on page 273.

- 3** Attach the presser foot.

- 4** Turn the handwheel toward you (counterclockwise), and then begin sewing around the edge of the appliqué, making sure that the needle drops just outside of the appliqué.

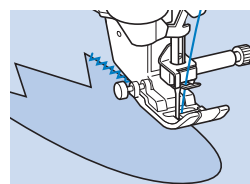

When sewing around corners, stop the machine with the needle in the fabric just outside of the appliqué, raise the presser foot lever, and then turn the fabric as needed to change the sewing direction.



■ Attaching Tape or Elastic

📖 Memo

- For details on stitch patterns, refer to “Stitch Chart” on page 273.

- 1 Select a straight stitch and attach zigzag foot “J”.
- 2 Set the stitch length to 4.0 mm (approx. 3/16 inch), and loosen the upper thread tension to 2.0. (page 61, page 62)

📖 Memo

- Be sure that neither automatic reinforcement  nor automatic thread cutting  is selected.

- 3 Sew two rows of straight stitches on the right side of the fabric, then pull the bobbin thread to create the necessary gather.

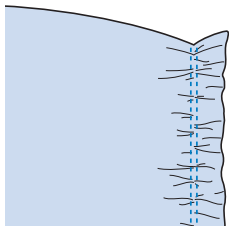

📖 Memo

- Before sewing the straight stitch, rotate the handwheel toward you (counterclockwise) and pull up the bobbin thread. Holding the top and bobbin thread, pull a length of thread out from the rear of the machine. (Be sure that the presser foot is raised.)

- 4 Place the tape over the gather, and hold it in place with basting pins.

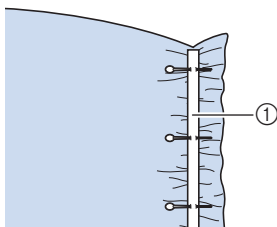

① Tape

- 5 Select a stitch.

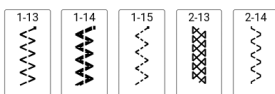

- 6 Sew over the tape (or elastic).

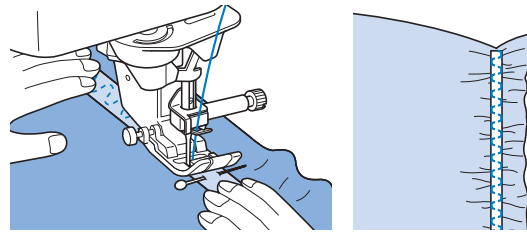

⚠ CAUTION

- Be sure the needle does not strike a basting pin, or any other objects, during sewing. The thread could tangle or the needle could break, causing injury.

- 7 Pull out the straight stitch threads.

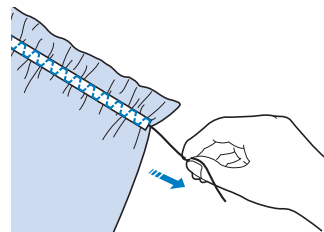

■ Gathering

Use on waists of skirts, sleeves of shirts, etc.

- 1 Select a straight stitch and attach zigzag foot “J”.
- 2 Set the stitch length to 4.0 mm (approx. 5/32 inch) and the thread tension to approximately 2.0 (weaker tension).
- 3 Pull the bobbin and upper threads out by 50 mm (approx. 2 inches). (page 41)
- 4 Sew two rows of straight stitches parallel to the seam line, then trim excess thread leaving 50 mm (approx. 2 inches).

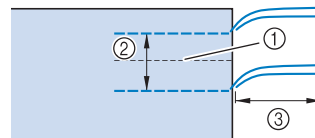

- ① Seam line
- ② 10 to 15 mm (approx. 3/8 inch to 9/16 inch)
- ③ About 50 mm (approx. 2 inches)

- 5** Pull the bobbin threads to obtain the desired amount of gather, then tie the threads.

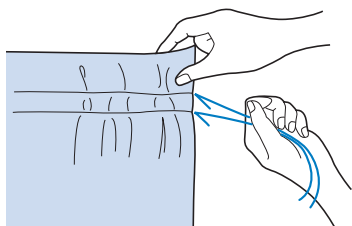

- 6** Smooth the gathers by ironing them.

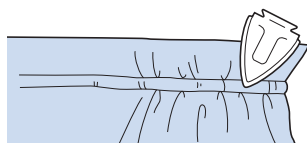



- 7** Sew on the seam line and remove the basting stitch.

■ Shell Tuck Stitches

The arched tucks that look like seashells lined up in a row are called “shell tucks”. They are used to decorate trims, the front of blouses or cuffs made of thin fabrics.

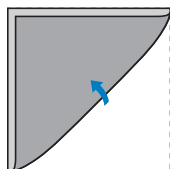
- 1** Draw equally spaced lines along the bias, and then fold the fabric along the lines.



- 2** Select , and then increase the thread tension.

- 3** Attach zigzag foot “J”.

- 4** Sew while making sure that the needle drops slightly off the edge of the fabric.

One fold at a time, continue folding the fabric along the line, then sewing it.

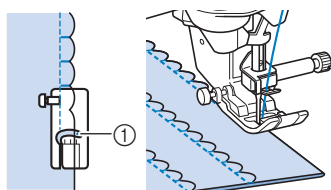

① Needle drop point

- 5** After sewing is finished, remove the fabric. Unfold the fabric, and then iron the tucks down to one side.

■ Scallop Stitches

This wave-shaped satin stitch is called “scalloping”. Use this stitch to decorate the edges of blouse collars and handkerchiefs or use it as a hem accent.

- 1** Select .

- 2** Attach advanced monogramming foot “N+”.

- 3** Stitch along the edge of the fabric, making sure not to sew directly on the edge of the fabric.

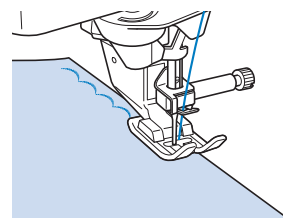

- 4** Trim along the stitches.

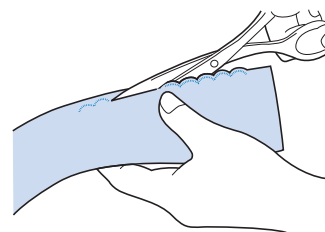

- Be careful not to cut the stitches.

Quilting



Memo

- The 40 quilting stitches Q-01 through Q-40, stitches S-03 through S-05 and the utility stitches with “P” or “Q” indicated on their key are useful for quilting.
- For details on stitch patterns, refer to “Stitch Chart” on page 273.

Piecing

Using Zigzag Foot “J”

Sewing two pieces of fabric together is called piecing. When cutting pieces for quilt blocks, make sure the seam allowance is 6.5 mm (approx. 1/4 inch).

1 Select  or  and attach zigzag foot “J”.

2 Align the edge of the fabric with the edge of the presser foot, and start sewing.

* When aligning the right side of the presser foot with the edge of the fabric, and sew using stitch .

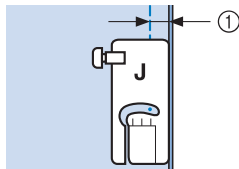

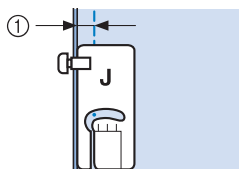

① 6.5 mm (approx. 1/4 inch)

* When aligning the left side of the presser foot with the edge of the fabric, and sew using stitch .



① 6.5 mm (approx. 1/4 inch)

Memo

- To change the needle position, use  or  in the [L/R Shift] display.
- You can sew piecing by referring to the guideline marker. For details, refer to “Specify the Guidelines” on page 65.

Piecing Using the 1/4" Piecing Foot with Guide

This piecing foot can sew an accurate 1/4-inch or 1/8-inch seam allowance. It can be used for piecing together a quilt or for topstitching.

1 Select , and then attach the 1/4" piecing foot with guide.

2 Use the guide and marks on the presser foot to sew accurate seam allowances.

Piecing a 1/4 inch seam allowance

Keep the edge of the fabrics against the guide as you sew.

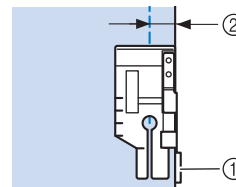

- ① Guide
- ② 1/4 inch

Creating an accurate seam allowance

Use the mark on the foot to begin, end, or pivot 1/4 inch from edge of fabric.

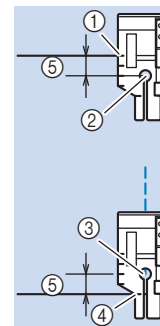

- ① Align this mark with edge of fabric to begin.
- ② Beginning of stitching
- ③ End of stitching
- ④ Opposite edge of fabric to end or pivot
- ⑤ 1/4 inch

Memo

- For details on pivoting, refer to “Pivoting” on page 72.

Topstitching quilting, 1/8 inch

Sew with the edge of the fabric or seam aligned with the left side of the presser foot's front section.

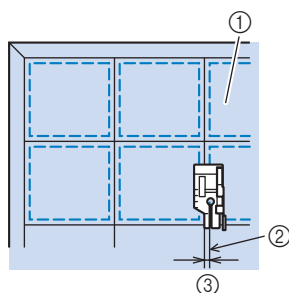

- ① Right side of fabric
- ② Seam
- ③ 1/8 inch

Quilting with the Compact Dual Feed Foot

Sewing the quilt top, batting, and backing together is called quilting. You can sew the quilt with the compact dual feed foot to keep the quilt top, batting, and backing from sliding.

1 Select a stitch.

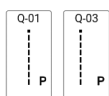

Note

- If necessary, adjust the stitch length. (page 61)

2 Attach the compact dual feed foot. (page 49)

3 Place one hand on each side of the presser foot to hold the fabric secure while sewing.

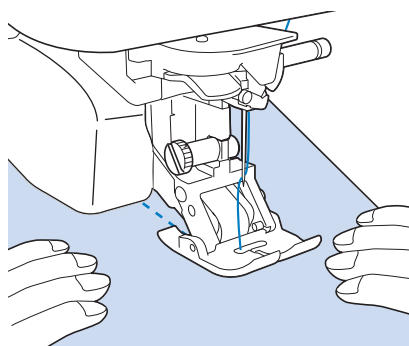

Memo

- Sew at slow to medium speed.
- Always check to be sure that your quilting surface is securely basted before beginning to sew.

Free Motion Quilting

With free motion quilting, the feed dogs can be lowered by touching then , so that the fabric can be moved freely in any direction. For free motion quilting, use free motion quilting foot "C" or free motion open toe quilting foot "O" depending on the stitch that is selected, and set the machine to free motion sewing mode. In this mode, the presser foot is raised to the necessary height for free motion sewing. We recommend attaching the foot controller and sewing at a consistent speed. You can adjust the sewing speed with the speed control slide on the machine.

CAUTION

- With free motion quilting, control the feeding speed of the fabric to match the sewing speed. If the fabric is moved faster than the sewing speed, the needle may break and cause injury.

Memo

- When starting to sew, the internal sensor detects the thickness of the fabric, and the quilting foot is raised to the height specified in the settings screen. Touch to display [Free Motion Foot Height] of the settings screen. Touch the number to select the height that the quilting foot is raised above the fabric. Increase the setting, for example, when sewing very stretchy fabric, so that it is easier to sew.



- In order to sew with a balanced tension, it may be necessary to adjust the upper thread tension. Test with a sample piece of fabric that is similar to your chosen fabric.

Note

- Do not be discouraged with your initial results. The technique requires practice.

■ Using Free Motion Quilting Foot “C”

Use free motion quilting foot “C” with the straight stitch needle plate for free-motion sewing with straight stitches.



⚠ CAUTION

- When using free motion quilting foot “C”, be sure to use the straight stitch needle plate and sew with the needle in middle (center) needle position. If the needle is moved to any position other than the middle (center) needle position, the needle may break, which may result in injuries.

1 Turn off the machine and remove the needle plate. (page 255)

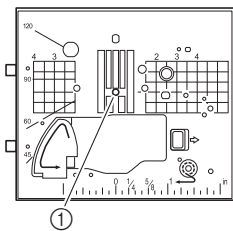

① Round hole

2 Select a stitch.

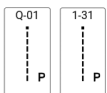

3 Touch then to set the machine to free motion sewing mode.

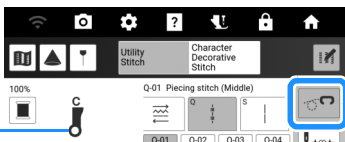
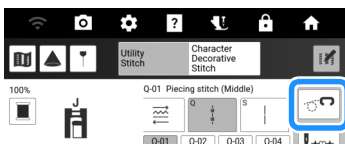

① Free motion quilting foot “C”

4 Remove the presser foot holder. (page 48)

5 Attach free motion quilting foot “C” as shown the illustration and tighten the presser foot holder screw.

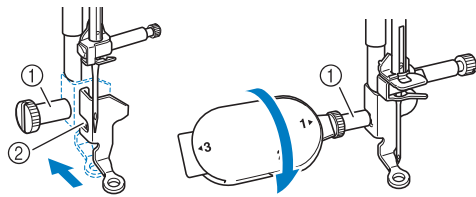

- ① Presser foot holder screw
- ② Notch

Note

- Make sure that the free motion quilting foot “C” is attached properly and not slanted.

⚠ CAUTION

- Be sure to securely tighten the screw with the included multi-purpose screwdriver. Otherwise, the needle may touch the quilting foot, causing it to break and causing injury.

6 Use both hands to stretch the fabric taut, and then move the fabric at a consistent pace in order to sew uniform stitches roughly 2.0-2.5 mm (approx. 1/16 - 3/32 inch) in length.

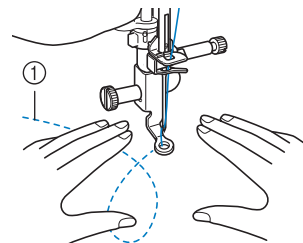

① Stitch

7 Touch to cancel the free motion sewing mode.

8 After sewing, make sure to remove the straight stitch needle plate and presser foot “C”, and reinstall the regular needle plate.

Memo

- Free motion open toe quilting foot “O” can also be used with the straight stitch needle plate. We recommend using free motion open toe quilting foot “O” with free motion sewing of fabrics of uneven thicknesses.

■ Using Free Motion Open Toe Quilting Foot “O”

The free motion open toe quilting foot “O” is used for free motion quilting with zigzag or decorative stitches or for free motion quilting of straight lines on fabric with an uneven thickness. Various stitches can be sewn using free motion open toe quilting foot “O”. For details on the stitches that can be used, refer to “Stitch Chart” on page 273.

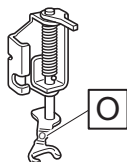

📖 Memo

- The standard needle plate must be used if zigzag or decorative stitch patterns are selected.

- 1 Touch then to set the machine to free motion sewing mode.
- 2 Select a stitch.
- 3 Remove the presser foot holder. (page 48)
- 4 Attach free motion open toe quilting foot “O” as shown the illustration and tighten the presser foot holder screw.

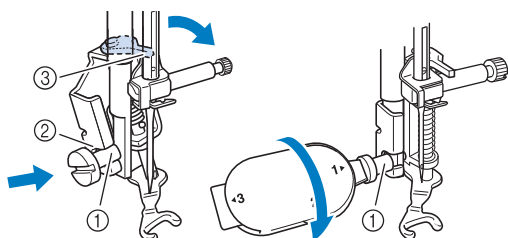

- ① Presser foot holder screw
- ② Notch
- ③ Pin

💡 Note

- Make sure that the free motion open toe quilting foot “O” is not slanted.

⚠ CAUTION

- Be sure to securely tighten the screw with the included multi-purpose screwdriver. Otherwise, the needle may touch the quilting foot, causing it to break and causing injury.

- 5 Use both hands to stretch the fabric taut, and then move the fabric at a consistent pace in order to sew uniform stitches roughly 2.0-2.5 mm (approx. 1/16 - 3/32 inch) in length.

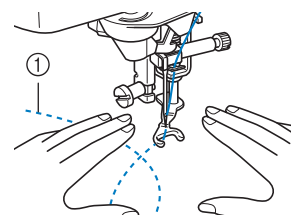

- ① Stitch

- 6 Touch to cancel the free motion sewing mode.

■ Echo Quilting

Sewing quilting lines at equal distances around a motif is called echo quilting. Use the free motion echo quilting foot “E” for echo quilting.

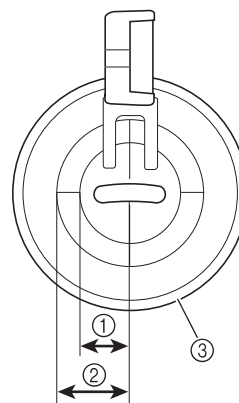

- ① 6.4 mm (approx. 1/4 inch)
- ② 9.5 mm (approx. 3/8 inch)
- ③ Free motion echo quilting foot “E”

- 1 Select .
- 2 Touch then to set the machine to free motion sewing mode.
- 3 Remove the presser foot holder and then attach the adapter. (page 48)

- 4** Position the free motion echo quilting foot “E” on the left side of the presser bar with the holes in the quilting foot and presser bar aligned.

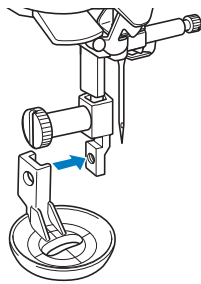

- 5** Tighten the screw (small) with the included screwdriver (large).

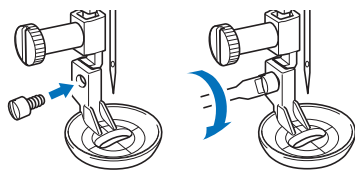

⚠ CAUTION

- Be sure to securely tighten the screws with the included screwdriver (large). Otherwise, the needle may touch the quilting foot, causing it to break and causing injury.

- 6** Using the measurement on the quilting foot as a guide, sew around the motif.

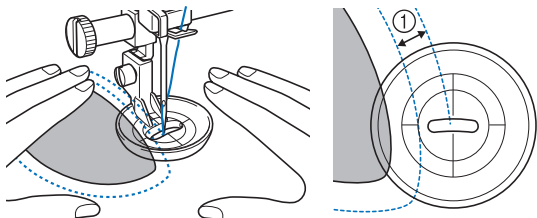

① 6.4 mm (approx. 1/4 inch)

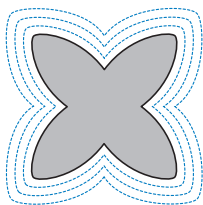

- 7** Touch  to cancel the free motion sewing mode.

Free-Motion Quilting/Basting with the Stitch Regulator

The stitch regulator allows free-motion quilting and free-motion basting with a set stitch length. The machine detects how the fabric is being moved and makes adjustments to ensure the set stitch length.

Names of Parts and Their Functions

Replace the presser foot to be used with the stitch regulator, according to your needs.

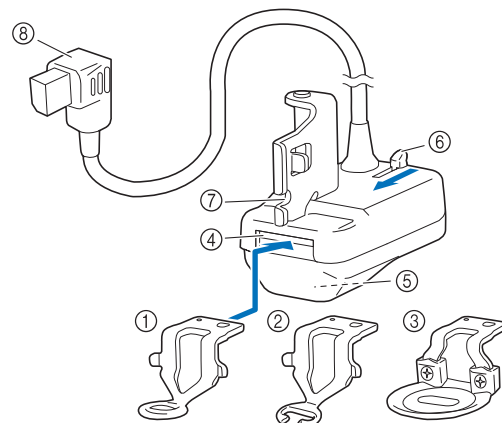

- ① **Stitch regulator quilting foot**
Used for general quilting.
- ② **Stitch regulator open toe quilting foot**
This presser foot enables you to easily check the needle and stitching. Carefully sew, making sure that the fabric does not catch on the tips of the presser foot. **Do not use this foot when selecting [Basting mode].**
- ③ **Stitch regulator echo quilting foot**
Used for echo quilting. This presser foot is also suitable for sewing furry fabric or fabric with an uneven surface or for sewing different types of fabric together.
- ④ **Presser foot slot**
- ⑤ **Stitch regulator window**
The inner sensor detects fabric movement.
- ⑥ **Presser foot release button**
Push this toward you to remove the presser foot.
- ⑦ **Notch in the stitch regulator**
- ⑧ **Connector of the stitch regulator**

■ Attaching the Stitch Regulator and Presser Foot

⚠ CAUTION

- Before installing or removing the stitch regulator or replacing the presser foot, be sure to touch  to lock all keys and buttons. Unintentional operations such as pressing a button may cause the machine to start operating, resulting in injuries.
- We strongly advise to not use the stitch regulator open toe quilting foot when in [Basting mode], as the possibility of needle breakage is increased.



IMPORTANT



- Do not install the stitch regulator onto the machine if the stitch regulator is wet or has been damaged from being dropped. The laser sensor may have been damaged.

💡 Note

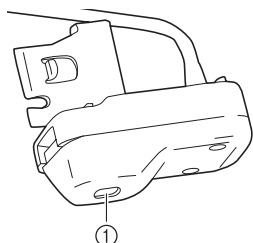
- Before using the stitch regulator, check the window at the bottom. Remove any accumulated dust or lint with a cotton swab or other soft object without damaging the built-in lens. Do not use hard objects such as needles or tweezers.



① Stitch regulator window

- 1** Press  (Needle position button) to raise the needle.
- 2** Touch  to lock all keys and buttons.
 - * If the message [OK to automatically lower the presser foot?] appears on the LCD screen, touch [OK] to continue.
- 3** Raise the presser foot lever.
- 4** Remove the presser foot and presser foot holder. (page 48)
- 5** Prepare the presser foot to be used with the stitch regulator.

- 6** If the presser foot already attached to the stitch regulator will not be used, slowly push the presser foot release button toward you as far as it will go, and then remove the presser foot after it has been ejected.

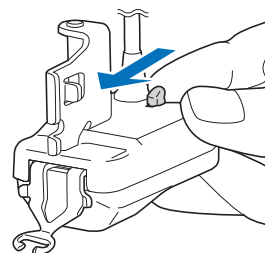

- 7** Correctly orient the presser foot, insert it horizontally into the presser foot slot, and then push it in as far as it will go.

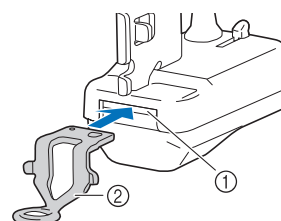

- ① Presser foot slot
- ② Presser foot

- 8** Pull the presser foot slightly toward you to check if it is firmly secured. If the presser foot comes out, reinsert it as far as it will go.

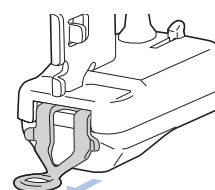

⚠ CAUTION

- Make sure that the presser foot is firmly secured. Otherwise, the presser foot may come off or the needle may break, causing injuries.

- 9** Align the notch in the stitch regulator with the screw on the presser bar, and then firmly tighten the screw.

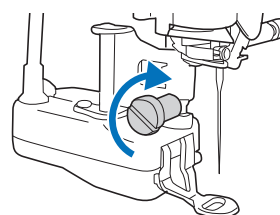

- 10** Plug the connector of the stitch regulator into the jack on the back of your machine.

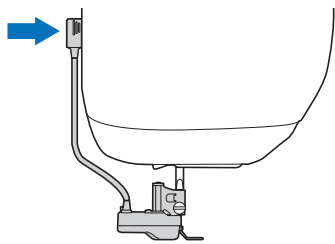

Memo

- Make sure that the stitch regulator harness does not catch on the presser foot lever.

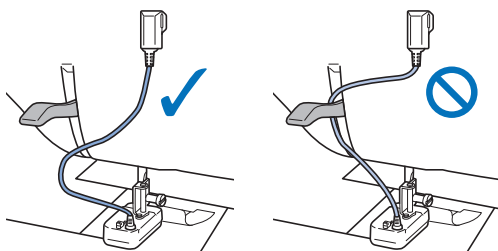

- 11** Touch  to unlock all keys and buttons.



Replacing the Presser Foot with the Stitch Regulator Installed

CAUTION

- When replacing the presser foot, make sure that the needle does not strike your fingers or the presser foot. Otherwise, injuries may result, or the needle or presser foot may become damaged.

Memo

- We recommend removing the fabric from the machine before replacing the presser foot.

- 1** Press  (Needle position button) to raise the needle.
- 2** Touch  to lock all keys and buttons.
- 3** To replace the presser foot, refer to steps **6** through **8** of “Attaching the Stitch Regulator and Presser Foot” on page 115. After replacing the presser foot, make sure that the thread is not caught in the stitch regulator.

* If the presser foot has been raised, lowering it will make it easier to replace it.

IMPORTANT

- If the thread has been caught in the stitch regulator, remove the presser foot, and then reattach it, making sure to avoid the thread.

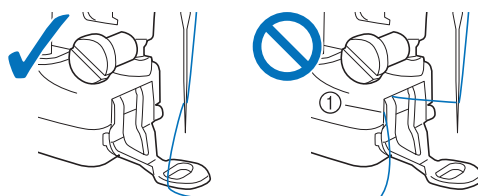

① The machine cannot sew if the thread is caught.

- 4** Touch  to unlock all keys and buttons.

■ Selecting the Stitch Pattern and Stitch Regulator Mode

1 With the Utility Stitch screen displayed, install the stitch regulator onto the machine.

→ When the message appears, touch [OK]. The stitch regulator sewing screen appears.

📖 Memo

- If the stitch regulator was installed with a screen other than the utility stitch screen displayed, touch [Sewing] in the home page screen to display the stitch regulator sewing screen.

2 Touch a key to select the appropriate mode.

- * If using the foot controller with any mode, stepping on the foot controller starts sewing when the stitch regulator detects fabric movement. Release the foot controller to stop sewing. If using the “Start/Stop” button, pressing the button starts sewing when the stitch regulator detects fabric movement. Press the button again to stop sewing.

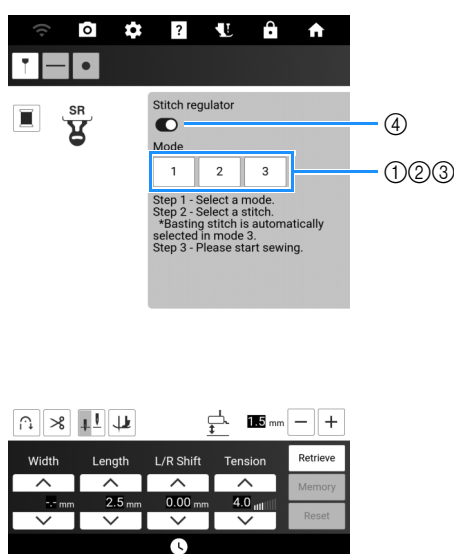

- ① Intermittent mode:** Stitches are sewn when the fabric is moved the set length. When the fabric is not being moved, the needle is raised, the machine enters standby, and the “Start/Stop” button flashes. Sewing starts when the fabric is moved while the button is flashing. A message appears and sewing ends when the fabric has not been moved for a certain period of time.
- ② Continuous mode:** Stitches are continuously sewn after sewing has been started. This is suitable for sewing shapes with corners such as rectangles. If the fabric is not being moved, stitches are slowly sewn at the same location. Since stitches continue to be sewn at the same location, be careful that the thread does not become tangled.

- ③ Basting mode:** Stitches are sewn spaced far apart. Stitches are sewn when the fabric is moved the set length. When the fabric is not being moved, the needle is raised, the machine enters standby, and the “Start/Stop” button flashes. Sewing starts when the fabric is moved while the button is flashing. A message appears and sewing ends when the fabric has not been moved for a certain period of time. Sew trial stitches, check the stitching and how easily the thread can be removed, and then adjust the thread tension if necessary.
- ④ Turn on or off [Stitch regulator].** When switched off, normal free-motion sewing is possible. Since the machine does not detect fabric movement, feed the fabric at a constant speed while you sew.

⚠ CAUTION

- While using the stitch regulator open toe quilting foot with [Stitch regulator] switched off, be careful not to pull the fabric forcefully, which could cause the needle to break.

3 Select a stitch pattern, and then set the stitch length.

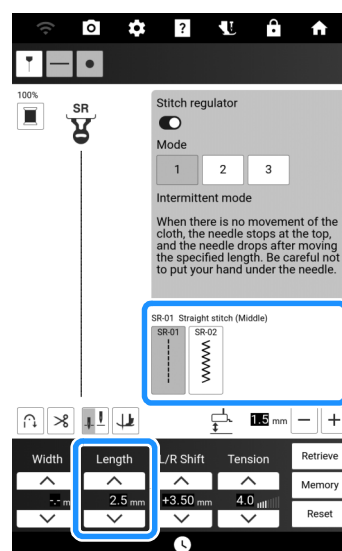

📖 Memo

- When using a straight stitch to sew small parts or stippling, we recommend setting the stitch length between 1 mm and 1.5 mm.
- Zigzag stitch patterns are suitable for thread painting.

4 Specify any other settings.

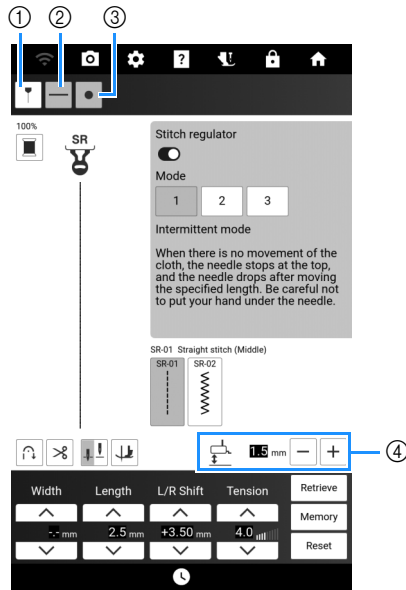

- ① Display the guidelines. (page 65)
- ② Switch on or off the projection of the stitch regulator sensor position. Select a projection color different from the projector's background color selected in the settings screen. Refer to step 1 of "Free-Motion Quilting/Basting with the Stitch Regulator" on page 118.
- ③ Switch on or off the projected status of the stitch regulator. Refer to step 1 of "Free-Motion Quilting/Basting with the Stitch Regulator" on page 118.
- ④ Adjust the height of the stitch regulator presser foot.

Memo

- For details on the other keys, refer to "Sewing Screens" on page 19.

Free-Motion Quilting/Basting with the Stitch Regulator

Note

- Before sewing your project, sew trial stitches with fabric and thread that are the same as those used in your project. The result may vary depending on the fabric and thread used, stitch regulator mode, presser foot height, and fabric movement.
- If stitches are skipped or the thread becomes frayed, try sewing test stitches under the following conditions.
 - Use the included ball point needle (gold colored) 90/14.
 - Specify a stitch length of 2 mm or less (when selecting [Intermittent mode] or [Continuous mode]).

CAUTION

- If the thread tension is too tight, pulling on the fabric could cause needle breakage.
- Move the fabric, making sure that your hands keep away from the needle during sewing. Otherwise, injuries may result.

- 1 Position the fabric on the machine. At this time, correctly orient the fabric and position it so that it is under the stitch regulator sensor during sewing.

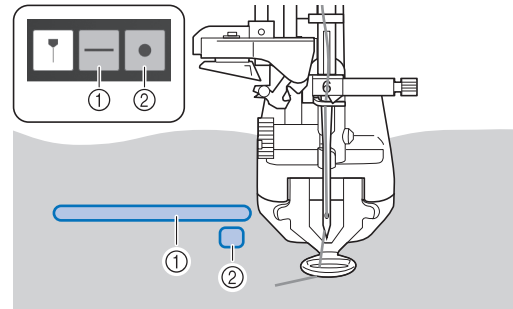

- ① This projected line indicates the position where the sensor can detect the fabric; it must be on the fabric while sewing.
- ② This projection indicates the status of the stitch regulator.
 - Lit in green: Ready to sew or sewing.
 - Flashing green: Standby in intermittent mode or basting mode.
 - Lit in red: Not ready to sew.
 - Off: The stitch regulator function is switched off, or the projection of the stitch regulator status is switched off (refer to step 4 of "Selecting the Stitch Pattern and Stitch Regulator Mode" on page 117).

Note

- If there is no fabric under the sensor, it will not be able to detect fabric movement and will not be able to sew at the set stitch length. If necessary, make sure that the fabric has a size that the sensor can detect.

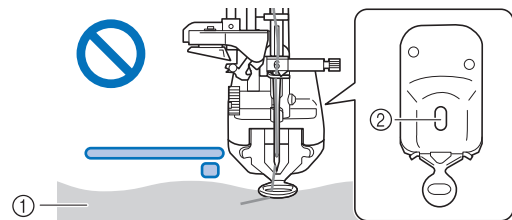

- ① The fabric cannot be detected because it is in front of the position where the sensor can detect it.
- ② Sensor location

- 2 Pull the bobbin thread up through the fabric.

- * Refer to "Pulling Up the Bobbin Thread" on page 41.

3 Lower the presser foot. Depress the foot controller or press the “Start/Stop” button, and then move the fabric.

Quilting

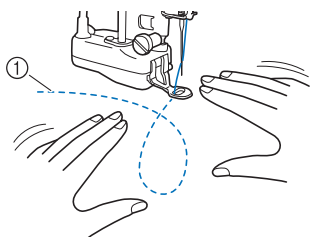

① Stitching

Basting

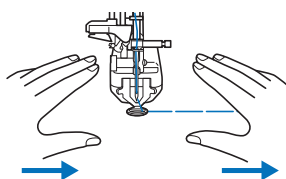

→ Stitches will be sewn at the set stitch length in response to the speed at which the fabric is moved.

Note

- Before sewing, make sure that a presser foot has been attached to the stitch regulator.
- Adjust the height of the stitch regulator presser foot so that the fabric can be smoothly moved. If the distance between the stitch regulator sensor and the fabric is too large, the sensor may not be able to accurately detect fabric movement. In that case, lower the height of the stitch regulator presser foot without hindering fabric movement.



- When the needle is up, move the fabric slowly and carefully. If the fabric is moved too quickly, an alarm will sound.
- Do not rotate the fabric while sewing. Otherwise, the stitch regulator sensor will not be able to correctly detect fabric movement.
- In order to sew stitches with a uniform length, move the fabric at a speed that does not cause the alarm to sound. The alarm volume can be adjusted in the settings screen.

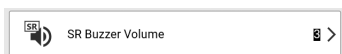

- In order to sew stitches at the set stitch length, move the fabric at least as much as the set stitch length.

4 Release the foot controller or press the “Start/Stop” button to stop sewing.

Memo

- With the needle stop position set to  (down), the needle remains lowered when sewing stops. When the foot controller is released after you stop moving the fabric, or when the “Start/Stop” button is pressed to finish sewing, an alarm sounds, and then the needle is lowered.
- Touch [Memory] to save the current settings. To retrieve the settings at a later time, touch [Retrieve]. For details, refer to “Saving the Utility Stitch Settings” on page 63.

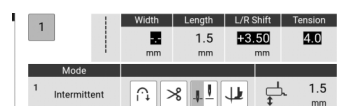

Hand-look Quilting

Sew hand-look quilting stitch patterns using the threads recommended below:

Upper thread: Use transparent nylon thread or lightweight thread that matches the color of the fabric for this thread to appear invisible.

Bobbin thread: Use a color that contrasts with the fabric for the stitch pattern to stand out.

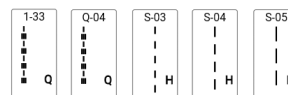

Memo

- For most fabrics and threads, using a 90/14 needle will result in a clean finish.
- To bring up more of the bobbin thread, increase the thread tension.
- S-03, S-04, S-05 are made up of several short stitches.

MY CUSTOM STITCH

Designing a Stitch

By using the MY CUSTOM STITCH function, you can register stitches you have created yourself. You can also sew designs combining MY CUSTOM STITCH creations with built-in characters. (page 59)

 **Memo**

- Stitches that you create with MY CUSTOM STITCH can be a maximum of 7 mm (approx. 9/32 inch) wide and 37 mm (approx. 1-1/3 inches) long.

- 1 Draw the stitch design on the grid sheet. Place points where the stitch pattern intersects with the grid, and connect all the points with a line.**

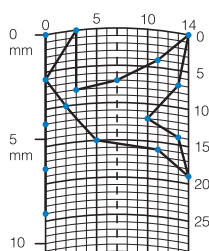

 **Memo**

- Simplify the design so that it can be sewn as a continuous line. For a more attractive stitch, close the design by intersecting lines.



If the design is to be repeated and linked, the start point and end point of the design should be at the same height.



- 2 Determine the x and y coordinates of each of the marked points.**

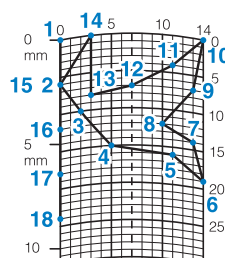

 **Memo**

- This will determine the stitch design that will be sewn.

Entering Stitch Data

Key Functions (MY CUSTOM STITCH Screen)

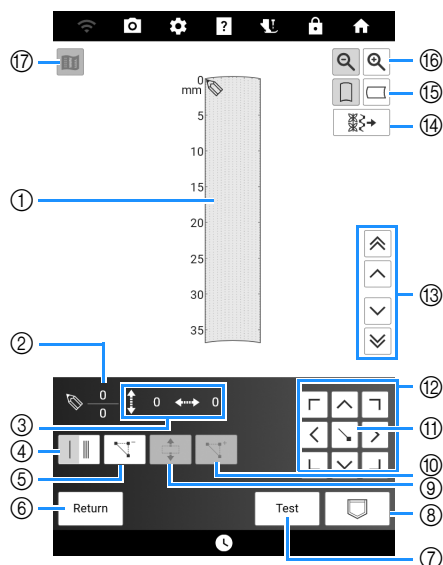

- ① This area displays the stitch being created.
- ② Displays the number of the present set point over the total number of points in the stitch.
- ③ Displays the y-coordinate of over the x-coordinate of .

No.	Display Name	Explanation	Reference
④		Touch this key to select whether one or three stitches will be sewn between two points.	121
	Single/triple stitching key		
⑤		Touch this key to delete a selected point.	121
	Point delete key		
⑥		Touch this key to exit the entering stitch data screen.	—
	Return key		
⑦		Touch this key to sew a test of the stitch.	121
	Test key		
⑧		Touch this key to store the stitch being created.	123
	MY CUSTOM STITCH memory key		
⑨		Touch this key to group points together and move them together.	122
	Block move key		
⑩		Touch this key to insert new points on the stitch design.	123
	Insert key		
⑪		Touch this key to set a point on the stitch design.	121, 122
	Set key		

No.	Display Name	Explanation	Reference
⑫		Use these keys to move over the display area.	121, 122
	Arrow keys		
⑬		Use these keys to move from point to point on the stitch, or to the first or last point entered on the stitch.	122, 123
	Point-to-point key		
⑭		Touch this key to edit the preset stitch patterns and saved stitch patterns.	124
	Import stitch patterns key		
⑮		Touch this key to change the direction of the grid sheet.	—
	Grid direction key		
⑯		Touch this key to see an enlarged version of the stitch being created.	—
	Enlarger key		
⑰		Touch this key to view an image of the stitch.	121
	Preview key		

Entering Points

- 1 Touch [Sewing] in the home page screen and then [Character Decorative Stitch].
- 2 Touch .

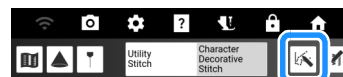

- 3 Use to move to the coordinates of the first point on the grid.

4 Touch to add the point indicated by .

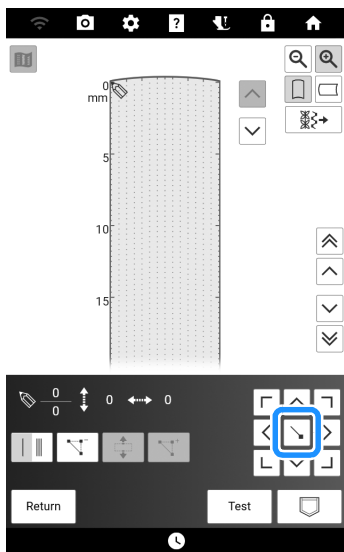

5 Select whether one stitch or triple stitches will be sewn between the first two points.

* To sew triple stitches, touch the key so that it appears as .

6 Repeat the steps for each point that you have drawn on the grid sheet until the stitch design is drawn on the screen as a continuous line.

- * Touch to delete a selected point entered.
- * Touch [Test] to sew a test-run of the stitch. Touch [Edit] to finish trial sewing and return to the previous screen.
- * Touch to view an image of the stitch.

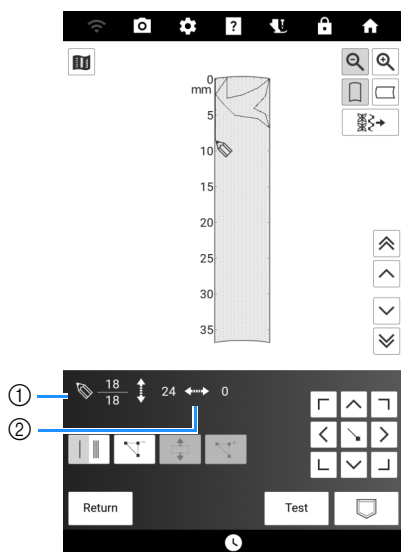

- ① Currently selected point/Total number of points
- ② Coordinates of

7 Once you finish entering the stitch data, touch to save the stitch pattern.

■ Moving a Point

1 Touch or to move to the point that you want to move.

- * To move to the first point, touch .
- * To move to the last point, touch .

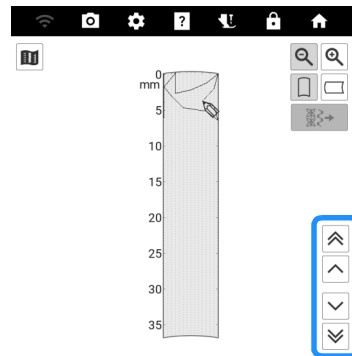



2 Use to move the point.

■ Moving Part or All of the Design

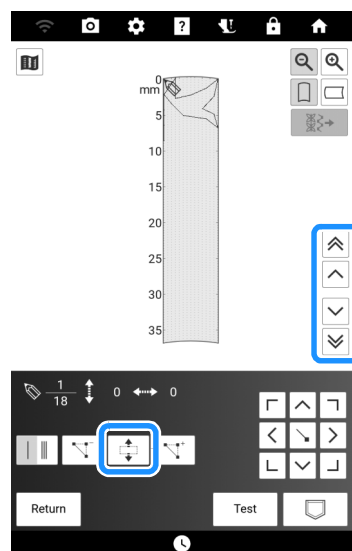
1 Touch or to move to the first point that you want to move. Touch .





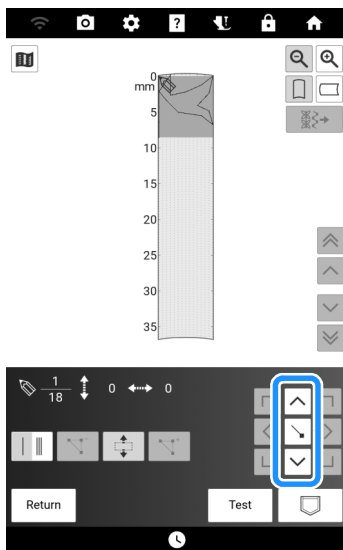

→ The selected point and all points that were entered after it are selected.

- 2 Touch  or  to move the section, and then touch .



→ The section will be moved.

■ Inserting New Points

- 1 Touch  or  to move  to a place on the design where you want to add a new point.
- 2 Touch .

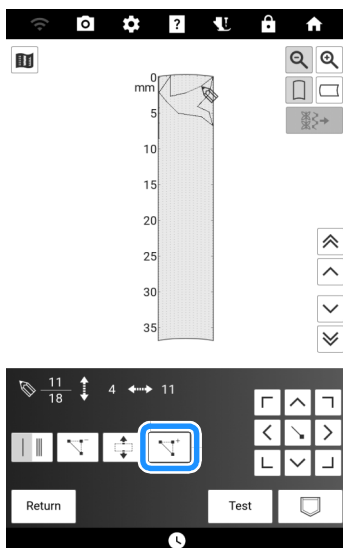

→ A new point is entered and  moves to it.

- 3 Use  to move the point.

Using the Memory Function (MY CUSTOM STITCH)

■ Saving Custom Stitch Patterns

- 1 Touch .

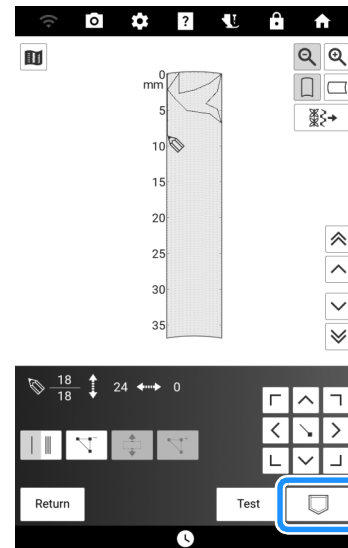

- 2 Refer to “Saving Character/Decorative Stitch Patterns” on page 64, and then save the custom stitch pattern.

■ Retrieving Custom Stitches

Refer to “Retrieving Stitch Patterns” on page 64.

■ Editing Retrieved Custom Stitch Patterns

1 Touch  .

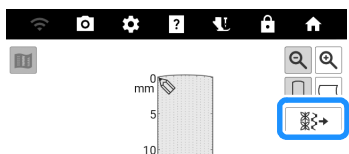

2 Select the stitch category. If selecting , touch the desired destination.

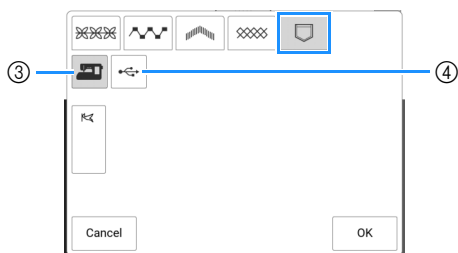
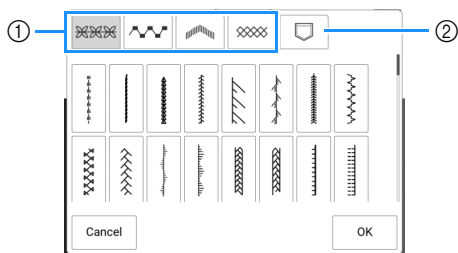

- ① Preset stitch patterns.
- ② Saved stitch patterns.
- ③ Retrieve from the machine's memory.
- ④ Retrieve from a USB media.

* If two USB media are connected to the machine, check the USB media names that are displayed, and then touch the name of the USB media that you wish to use.

3 Select the stitch pattern you want to edit and touch [OK].

Chapter 4 Basic Embroidery

Embroidering Preparation

Embroidery Step by Step

Follow the steps below to prepare the machine for embroidery.

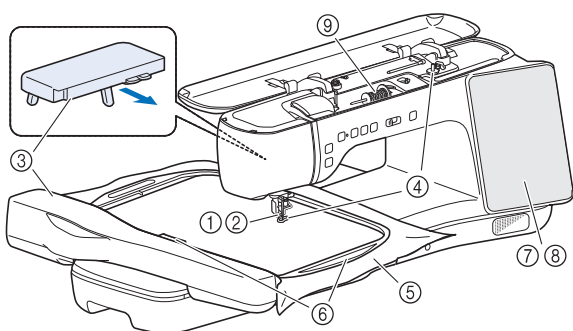

	Aim	Action	Reference
①	Presser foot attachment	Attach embroidery foot "W".	125
②	Checking the needle	Use needle 75/11 for embroidery.	36
③	Embroidery unit/Support table attachment	Attach the embroidery unit and support table.	126
④	Bobbin thread setup	For the bobbin thread, wind embroidery bobbin thread and set it in place.	37
⑤	Fabric preparation	Attach a stabilizer material to the fabric, and hoop it in the embroidery frame.	127
⑥	Embroidery frame attachment	Attach the embroidery frame to the embroidery unit.	131
⑦	Pattern selection	Turn the main power to ON, and select an embroidery pattern.	134
⑧	Checking the layout	Check and adjust the size and position of the embroidery.	139
⑨	Embroidery thread setup	Set up embroidery thread according to the pattern.	42

Attaching Embroidery Foot "W"

⚠ CAUTION

- When attaching an embroidery foot, always touch  on the screen. You may accidentally press the "Start/Stop" button and possibly cause injury.
- Be sure to use the embroidery foot "W" when doing embroidery. Otherwise, the needle may break and cause injury.
- Use the included multi-purpose screwdriver to firmly tighten the screw of the presser foot holder. If the screw is loose, the needle may strike the embroidery foot and break, possibly causing injury.

- 1 Touch . Remove the presser foot and presser foot holder. (page 48)
- 2 Position the embroidery foot "W" on the presser foot bar by aligning the notch of the presser foot to the screw.

Side view

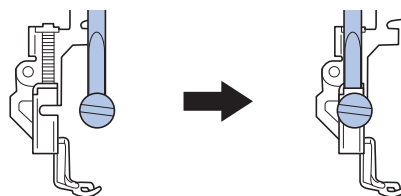

- 3 Hold the embroidery foot in place with your right hand, and then use the included multi-purpose screwdriver to securely tighten the presser foot holder screw.

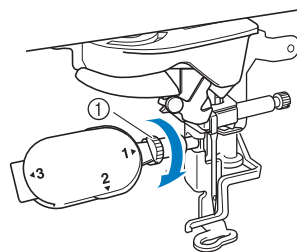

① Presser foot holder screw

- 4 Touch  to unlock all keys and buttons.

→ All keys and operation buttons are unlocked, and the previous screen is displayed.

Attaching the Embroidery Unit

⚠ CAUTION

- Do not move the machine with the embroidery unit attached. The embroidery unit could fall off and cause injury.

IMPORTANT

- Keep your hands and foreign objects away from the embroidery carriage and embroidery frame when the machine is embroidering. Damage or malfunction may result.
- Be sure to turn off the power before attaching or removing the embroidery unit. Otherwise, the machine may be damaged.
- Do not touch the inner connector of the embroidery unit. The pins on the embroidery unit connection may be damaged.
- Do not apply strong force to the embroidery unit carriage or pick up the unit by the carriage. Otherwise, the embroidery unit may be damaged.
- Do not push on the carriage when attaching the embroidery unit onto the machine. Moving the carriage may damage the embroidery unit.
- Make sure that there is enough space for the carriage of the embroidery unit to move. If the embroidery frame comes into contact with an object, the pattern may not be embroidered correctly, or damage may result. 50 cm (approx. 20 inches) clearance needed from back embroidery unit.

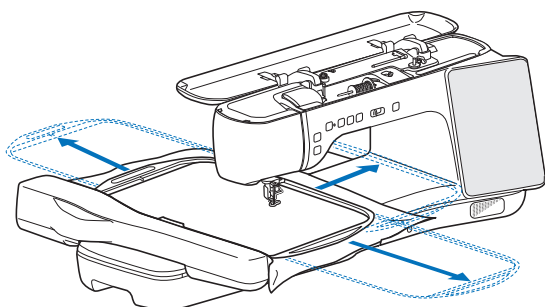

- Do not touch the embroidery carriage until the initialization finishes.

💡 Note

- When embroidering, install the support table. Using the support table to support the embroidery frame and fabric allows you to maintain stitching quality.
- To avoid distorting your embroidery design, do not touch the embroidery carriage and frame when the machine is embroidering.
- Store the embroidery unit in a safe place to prevent damage to the unit.

📖 Memo

- You can also sew utility/decorative stitches with the embroidery unit attached. Touch  and [Sewing] in the home page screen.

■ Attaching the Embroidery Unit

- 1 Turn the main power to OFF, and remove the flat bed attachment.

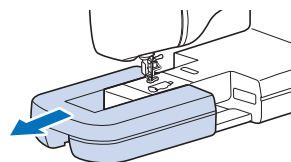

- 2 Insert the embroidery unit connection into the connection port of the machine until it snaps into place.

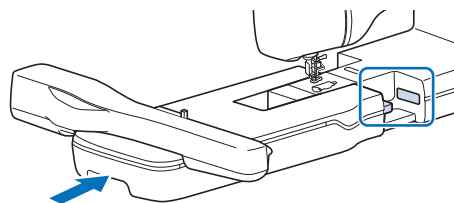

💡 Note

- Be sure there is no gap between the embroidery unit and the machine. If there is a gap, the embroidery patterns will not embroider with the correct registration.

- 3 Raise the three legs on the back of the support table until they snap into place, and then position the support table so that the side with the △ marks face up.

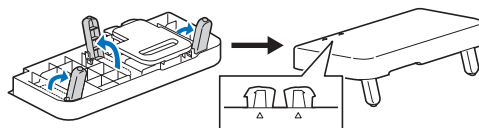

- 4 Align the △ marks on the back of the machine and on the support table, and then insert the tab into the machine.

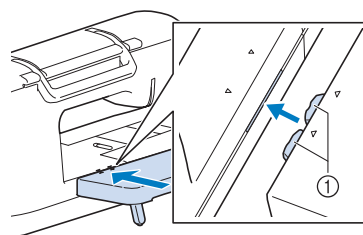

① Tab

- 5 Turn the main power to ON.

6 Touch [OK].

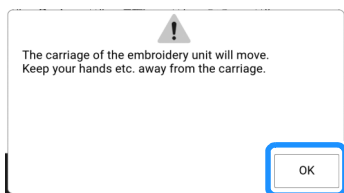

→ The carriage will move to the initialization position.

■ Removing the Embroidery Unit

1 Remove the embroidery frame.

* For details on removing the embroidery frame, refer to “Removing the Embroidery Frame” on page 132.

2 Touch [Embroidery] in the home page screen, then touch .

→ The carriage will move to the removal position.

3 Turn the main power to OFF.

4 Press the release lever, and pull the embroidery unit away from the machine.

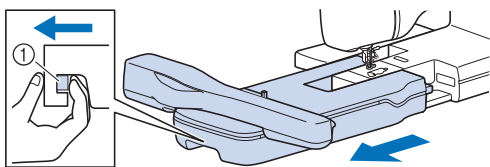

① Release lever

Memo

- Utility stitches can also be sewn with the support table attached. We recommend that the support table always be attached to the machine.

Before transporting the machine, pull the release lever toward you to remove the support table.

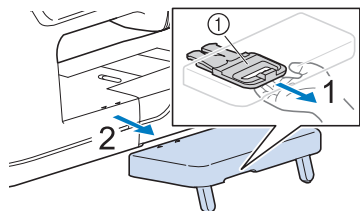

① Release lever

Hooping the Fabric in the Embroidery Frame

CAUTION

- Use fabrics with a thickness of less than 2 mm (approx. 1/16 inch). Using fabrics thicker than 2 mm (approx. 1/16 inch) may cause the needle to break and cause injury.
- Always use a stabilizer material for embroidery when embroidering stretch fabrics, lightweight fabrics, fabrics with a coarse weave, or fabrics which cause pattern shrinkage. Otherwise, the needle may break and cause injury.

■ Attaching Stabilizer to Fabric

1 Iron the iron-on stabilizer material to the wrong side of the fabric.

- Use a piece of stabilizer which is larger than the embroidery frame being used.

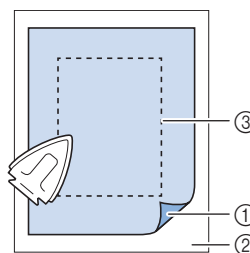

- ① Fusible side of stabilizer
- ② Fabric (wrong side)
- ③ Size of the embroidery frame

Note

- When using fabrics that cannot be ironed (such as terry cloth or fabrics that have loops which expand when ironed) or in places where ironing is difficult, position the stabilizer material under the fabric without fusing it, then position the fabric and stabilizer in the embroidery frame.

Memo

- When embroidering small pieces of fabric that cannot be hooped in an embroidery frame, use stabilizer material as a base. After lightly ironing the fabric to the stabilizer material, hoop it in the embroidery frame. If stabilizer material cannot be ironed onto the fabric, attach it with a basting stitch. After completing the embroidery, remove the stabilizer material carefully.

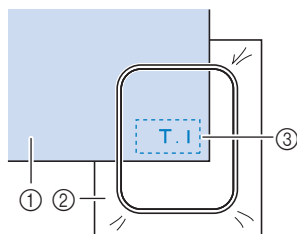

- ① Fabric
- ② Stabilizer
- ③ Basting

- When embroidering on thin fabrics such as organdy or lawn, or on napped fabrics such as towel or corduroy, use water soluble stabilizer (sold separately) for best results. In the case of thick terry cloth towels we recommend that you place a piece of water soluble stabilizer on the top surface of the towel. This will help to reduce the nap of the toweling and result in more attractive embroidery.

Types of Embroidery Frames

Embroidery frame	Embroidering area
	465 mm × 297 mm (approx. 18-1/4 inches × 11-5/8 inches) (page 128)
	272 mm × 272 mm (approx. 10-5/8 inches × 10-5/8 inches) (page 129)
	180 mm × 130 mm (approx. 7 inches × 5 inches) (page 130)
	100 mm × 100 mm (approx. 4 inches × 4 inches) (page 130)

Inserting Fabric into Embroidery Frame (465 mm × 297 mm (approx. 18-1/4 inches × 11-5/8 inches))

- Loosen the lever on the outer frame, and then remove the inner frame.**

* If the inner frame cannot be removed, loosen the frame adjustment screw.

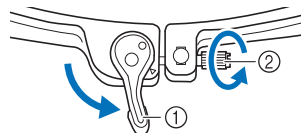

- ① Lever
- ② Frame adjustment screw

- With the embroidery frame guide on the left, place the fabric on top of the outer frame. Check that the rectangular area (④) of the inner frame faces up, and then re-insert the inner frame, making sure to align the inner frame's ▲ with the outer frame's ▼, to clamp the fabric. The top of the inner frame must be tucked under the flanges at the top of the outer frame.**

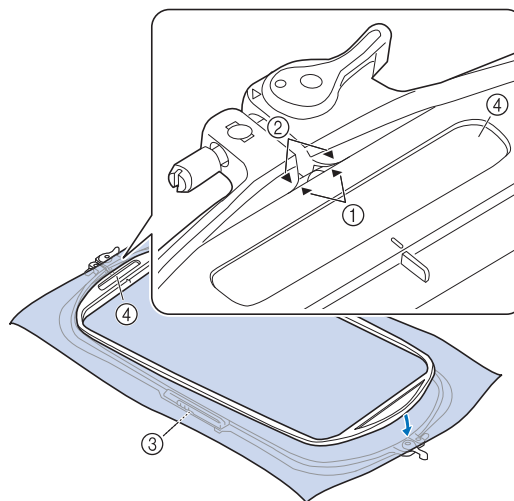

- ① Inner frame's ▲
- ② Outer frame's ▼
- ③ Embroidery frame guide
- ④ Rectangular area

Memo

- If the inner frame for this hoop is installed incorrectly, it may come apart and embroidery will not be performed correctly.

- 3** With the lever at the top tightened, push the inner frame down into the outer frame.

* Loosen the lever at the bottom.

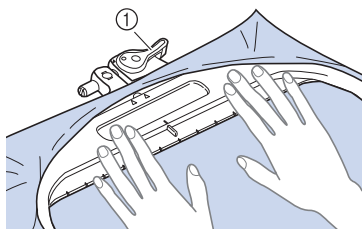

① Tighten the lever at the top.

- 4** Push the inner frame down into the outer frame in the order shown (from top to bottom).

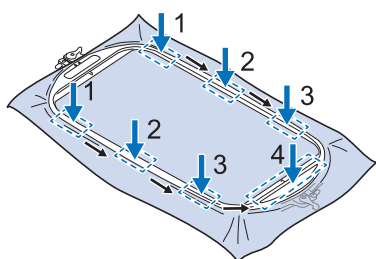

- 5** Gently smooth out the fabric. With the lever at the bottom loosened, slightly tighten the frame adjustment screw, and then pull the edges of the fabric to remove any slack.

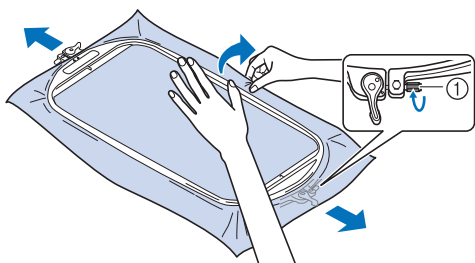

① Frame adjustment screw

Note

- If the fabric is not taut at the top, such as when thick fabric is used, slightly loosen the lever at the top, loosen the frame adjustment screw at the top, and then pull the edges of the fabric to remove any slack.

- 6** After stretching the fabric, make sure that it is taut and that the inner and outer frames are aligned.

* Make sure the inner and outer frames are even before you start embroidering.

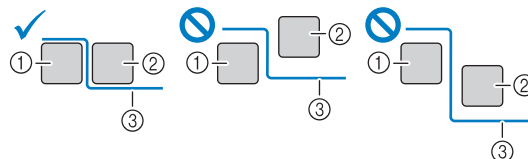

- ① Outer frame
- ② Inner frame
- ③ Fabric

- 7** Tighten the lever at the bottom.

* If the lever cannot be tightened, loosen the frame adjustment screw.

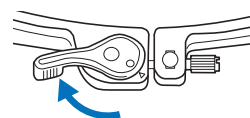

■ Inserting Fabric into Embroidery Frame (272 mm × 272 mm (approx. 10-5/8 inches × 10-5/8 inches))

- 1** Loosen the lever on the outer frame, and then remove the inner frame.

* Refer to step **1** of “Inserting Fabric into Embroidery Frame (465 mm × 297 mm (approx. 18-1/4 inches × 11-5/8 inches))” on page 128.

- 2** Perform steps **2** through **5** of “Inserting the Fabric into Embroidery Frame without Levers” on page 130.

- 3** Tighten the frame adjustment screw and tighten the lever.

* Refer to “Inserting Fabric into Embroidery Frame (465 mm × 297 mm (approx. 18-1/4 inches × 11-5/8 inches))” on page 128, then go to step **7**.

■ Inserting the Fabric into Embroidery Frame without Levers

💡 Note

- If the fabric is not securely held in the embroidery frame, the embroidery design will embroider out poorly. Insert the fabric on a level surface, and gently stretch the fabric taut in the embroidery frame.

1 Lift-up and loosen the frame adjustment screw and remove the inner frame.

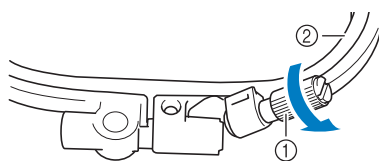

- ① Frame adjustment screw
- ② Inner frame

2 Lay the fabric right side up on top of the outer frame.

3 Re-insert the inner frame making sure to align the inner frame's △ with the outer frame's ▽.

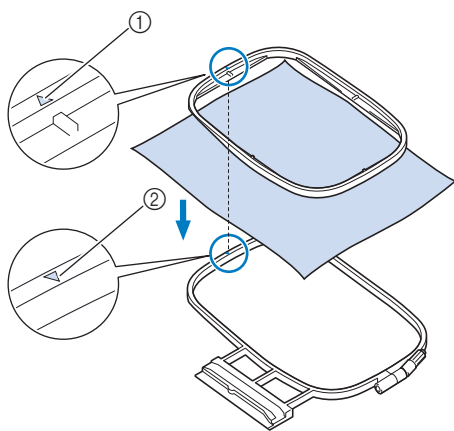

- ① Inner frame's △
- ② Outer frame's ▽

4 Slightly tighten the frame adjustment screw, and then remove the slack in the fabric by pulling on the edges and corners.

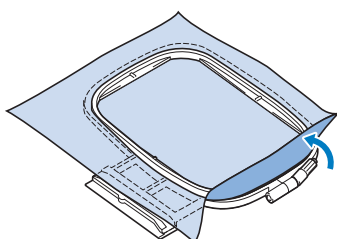

5 Gently smooth out the fabric. Make sure fabric is flat and without wrinkles.

- * After stretching the fabric, make sure the fabric is taut.

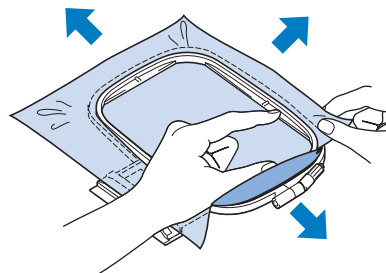

- * Make sure the inner and outer frames are even before you start embroidering.

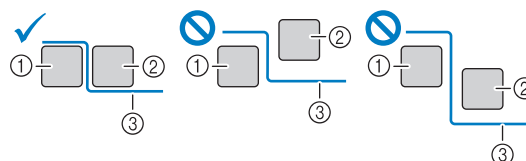

- ① Outer frame
- ② Inner frame
- ③ Fabric

6 Tighten the frame adjustment screw. Return the frame adjustment screw to its initial position.

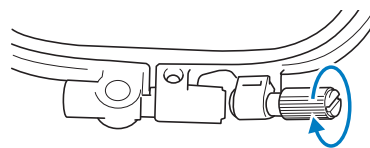

📖 Memo

- You can use the included multi-purpose screwdriver, setting the position to "3", when you loosen or tighten the frame adjustment screw.

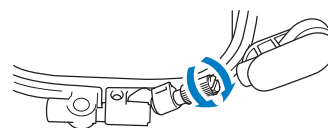

■ Using the Embroidery Sheet (Sold Separately)

When you want to embroider the pattern in a particular place, use the embroidery sheet (sold separately) with the embroidery frame.

- 1 With a chalk pencil, mark the area of the fabric you want to embroider.
- 2 Place the embroidery sheet on the inner frame. Align the guide lines on the embroidery sheet with the mark you made on the fabric.

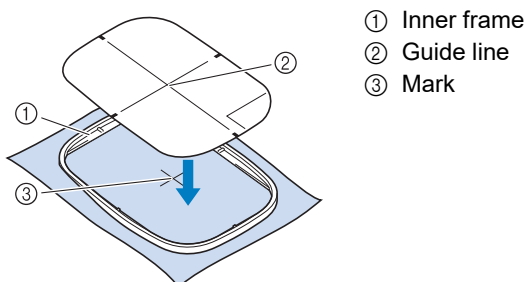

- 3 Gently stretch the fabric so there are no folds or wrinkles, and press the inner frame into the outer frame.

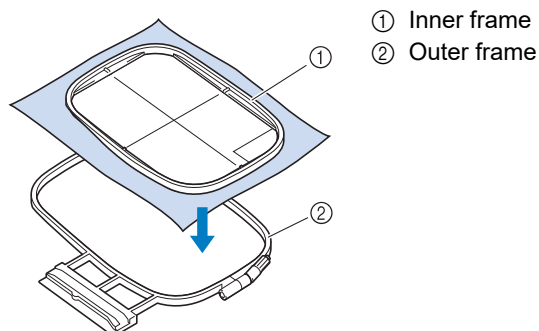

- 4 Remove the embroidery sheet.

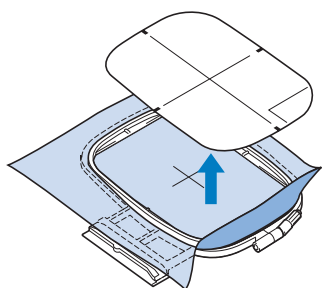

Attaching the Embroidery Frame

Note

- When attaching/removing the 465 mm × 297 mm (approx. 18-1/4 inches × 11-5/8 inches) embroidery frame to/from the machine, angle the embroidery frame so that the lever at the top does not hit the embroidery foot, as shown in the illustration. If the embroidery frame lever is hidden by the fabric, attach/remove it so that the rectangular area (indentation) of the inner frame does not touch the presser foot.

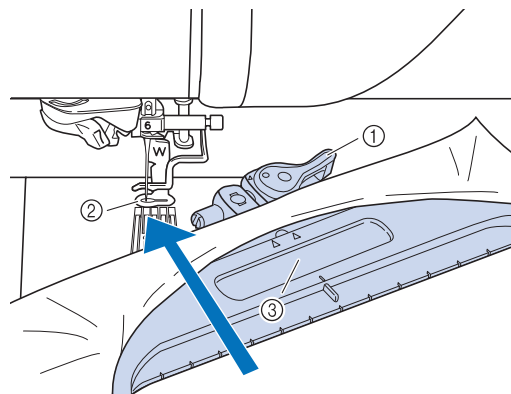

- ① Embroidery frame lever
② Embroidery foot
③ Rectangular area (indentation) (Make sure that this area does not touch the embroidery foot.)

- Wind embroidery bobbin thread and insert the bobbin before attaching the embroidery frame. Check that there is enough thread in the bobbin.
- Make sure that the frame-securing lever is correctly lowered after the embroidery frame has been installed in the embroidery frame holder.

- 1 Press  (Presser foot lifter button) to raise the embroidery foot.
- 2 Align the embroidery frame guide with the right edge of the embroidery frame holder.

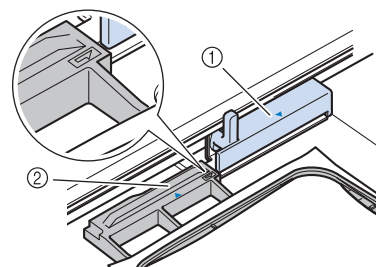

- ① Embroidery frame holder
② Embroidery frame guide

- 3** Slide the embroidery frame into the holder, making sure to align the embroidery frame's \triangle with the holder's ∇ .

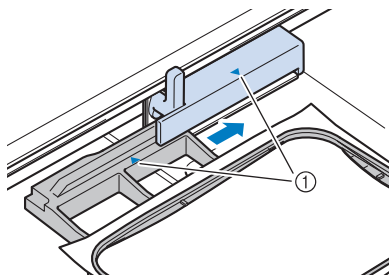

① Arrow mark

- 4** Lower the frame-securing lever to be level with the frame to secure the embroidery frame in the embroidery frame holder.

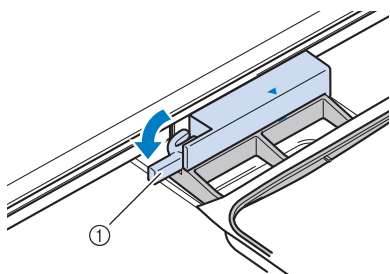

① Frame-securing lever

■ Removing the Embroidery Frame

- 1** Raise the frame-securing lever.

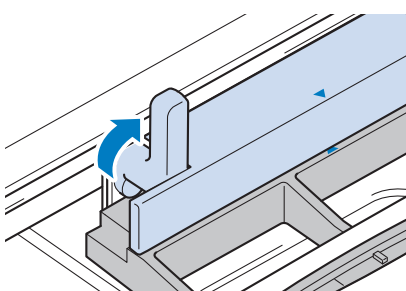

- 2** Pull the embroidery frame toward you.

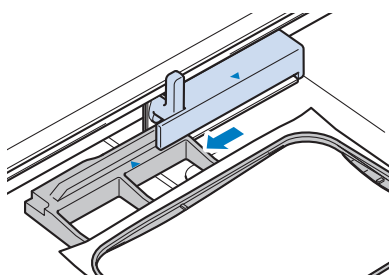

Embroidering Attractive Finishes

Many factors are involved in achieving a beautiful embroidery result. Using the appropriate stabilizer (page 127) and hooping the fabric in the embroidery frame (page 130) are two important factors mentioned earlier. There are several other factors as well.

⚠ CAUTION

- When embroidering large items (especially jackets or quilts), do not let the fabric hang off of the table. Otherwise, the embroidery unit cannot move freely and the embroidery frame may strike the needle, causing the needle to break and possibly causing injury.

💡 Note

- Recommended to do trial embroidery using same fabric and threads as project in order to check the embroidering results.

■ Thread

Upper thread	Use embroidery thread intended for use with this machine. For most embroidery applications, the upper thread should be 40-weight rayon or polyester embroidery thread.
Bobbin thread	Use the included 60 weight embroidery bobbin thread or recommended 60 weight embroidery bobbin thread.

■ Bobbin Case

Standard bobbin case (recommended for sewing and for embroidering with included 60 weight bobbin thread)

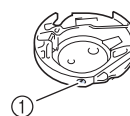

- ① Standard bobbin case (green marking on the screw)

Standard bobbin case originally installed in the machine has a green marking on the screw. We recommend using the included embroidery bobbin thread with this bobbin case. Do not adjust the tension screw on this bobbin case with the green marked screw.

Alternate bobbin case (recommended for embroidering with 90 weight bobbin thread or any other specialty thread when adjusting the bobbin thread tension)

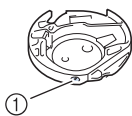

- ① Alternate bobbin case (no color on the screw)

The bobbin case with no color on the screw is set with tighter tension for embroidery with different weights of bobbin threads and a variety of embroidery techniques. This bobbin case is identified with a dark colored mark on the inside of the bobbin cavity. The tension screw on this case can be adjusted if necessary. (page 166)

Embroidery Needle Plate Cover

Under some conditions, based on the type of fabric, stabilizer or thread being used, there may be some looping in the upper thread. In this case, insert the embroidery needle plate cover into the notches on the needle plate as shown below.

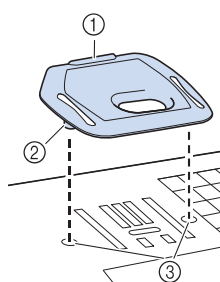

- ① Groove
② Projection
③ Notch

CAUTION

- Push the embroidery needle plate cover as far as possible to attach it. If the embroidery needle plate cover is not securely attached, it may cause the needle to break and cause injury.

To remove the embroidery needle plate cover, place your fingernail in the groove and lift the plate out.

Note

- Do not use the embroidery needle plate cover for any applications other than embroidery.

Embroidery Speed

Decrease the embroidery speed when embroidering on thin, thick, or heavy fabrics and when using a specialty thread like a metallic thread. You can specify the embroidery speed in the settings screen. SPM is the number of stitches embroidered in one minute.

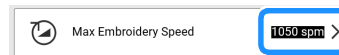

Embroidery Foot Height

When embroidering thick or puffy fabrics, a better result can be achieved by adjusting the embroidery foot height in the settings screen.

Touch , and set the [Embroidery Foot Height] to a larger number in order to increase the space between the embroidery foot and the needle plate.



Embroidering Patterns

Copyright Information

The patterns stored in the machine and patterns sold separately are intended for private use only. Any public or commercial use of copyrighted patterns is an infringement of copyright law and is strictly prohibited.

Embroidery Pattern Categories

Memo

- Refer to the “Embroidery Design Guide” for more information on each category’s embroidery pattern.
Visit <https://s.brother/cmdae/>.

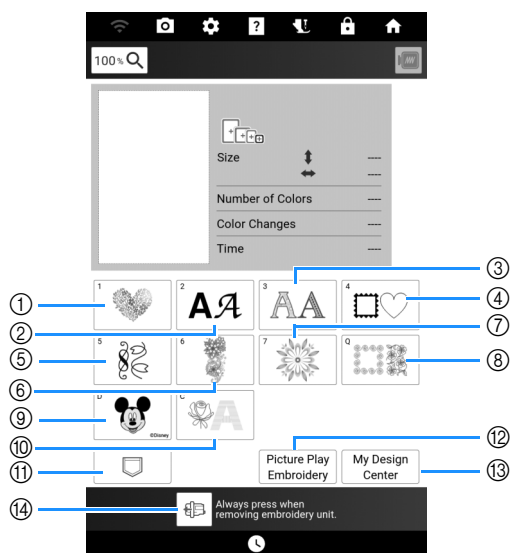

- Embroidery patterns
- Character patterns (page 137)
- Decorative alphabet patterns
- Frame patterns
- Buttonhole/Eyelet patterns/Design Patterns (for Buttonhole Decoration)/Utility embroidery patterns
- Split embroidery patterns (page 212)
- Long-Stitch embroidery patterns
Before embroidering, refer to the “Embroidery Design Guide”, which includes precautions for obtaining best results.
- Quilt sashes and edge-to-edge quilt patterns (page 195, page 201, page 203, page 208)
- Disney patterns
- Couching patterns (page 191)
- Patterns saved in the machine’s memory, USB media, etc. (page 168)
- Picture Play embroidery function (page 177)
- My Design Center (page 227)
- Touch this key to position the embroidery unit for storage (page 127)

Selecting Embroidery Patterns

- Touch [Embroidery] in the home page screen and then the category key you want to embroider.

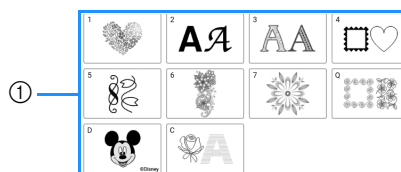

- Pattern category keys

- Select the sub-category, and then select the pattern that you want to embroider.

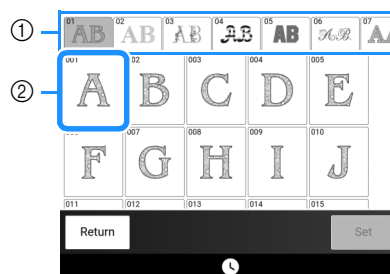

- Sub-category
- Embroidery pattern

- Touch [Set].

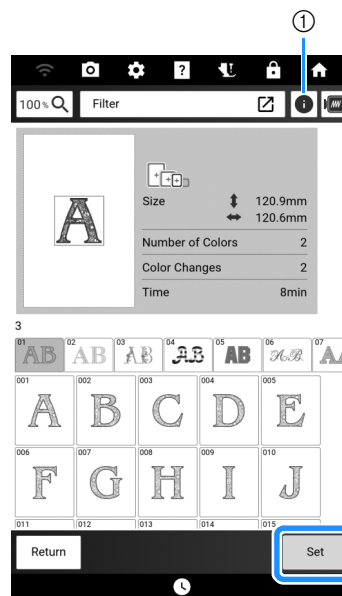

- Touch this key to see detailed information about the selected pattern.

4 If necessary, touch [Edit] to edit the selected pattern.

* Refer to “Embroidery Edit Screen” on page 142 about the “Edit” display.

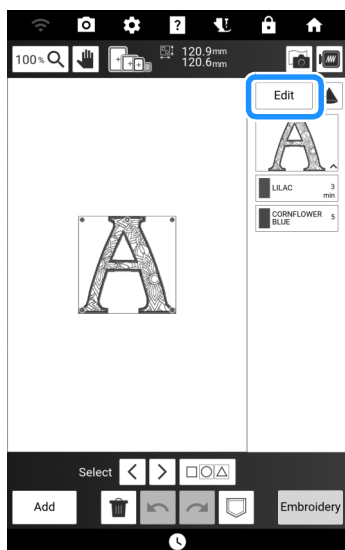

5 Touch [Embroidery].

→ The embroidery screen is displayed.

6 If necessary, touch [Layout] to reposition the pattern.

* Refer to “Embroidery Screen” on page 145.

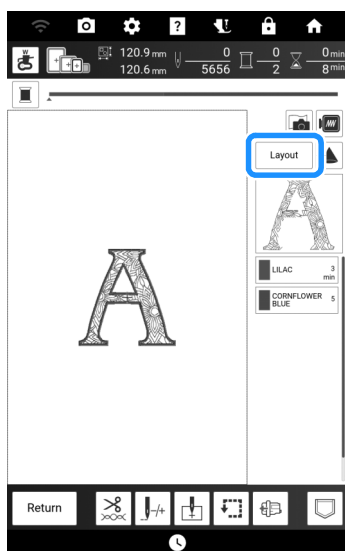

7 Start embroidering. (page 140)

Filtering the Embroidery Patterns

The embroidery patterns can be filtered based on size or number of thread colors.

1 Select the category of embroidery patterns to be filtered.

* The following categories can be filtered.

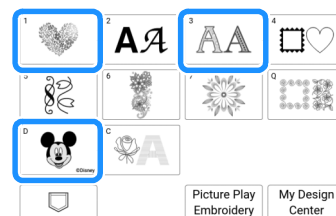

2 Touch [Filter].

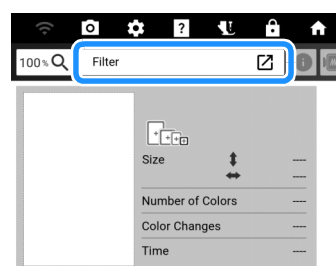

3 Specify the upper and lower limits of the embroidery pattern size or the number of thread colors.

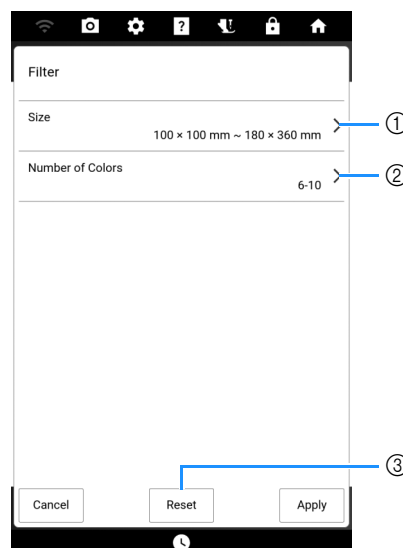

- ① Specify the upper and lower limits of the embroidery pattern size.
- ② Specify the number of thread colors. Touch the check boxes for the desired number of thread colors so that the check mark appears.
- ③ Reset the specified settings.

4 Touch [Apply].

→ The patterns that meet the specified conditions appear. If a pattern size is specified, the patterns are sorted by size. If the number of thread colors is specified, the patterns are sorted by the number of thread colors. If both pattern size and number of thread colors are specified, the patterns are sorted by size.

5 Select a pattern, and then touch [Set].

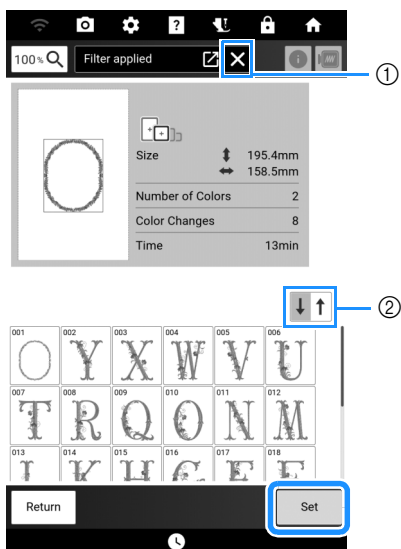

- ① Reset the filter.
- ② Switch between descending and ascending order.

Selecting Frame Patterns

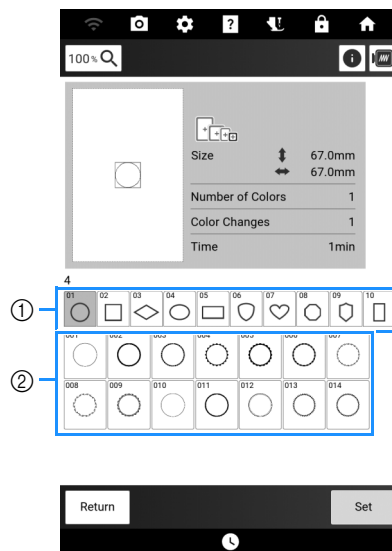

- 1 Touch .
- 2 Touch the key of the frame shape you want to embroider in the top part of the screen. And then, touch the key of the frame pattern you want to embroider.



- ① Frame shapes
- ② Frame patterns

- 3 Follow steps 3 through 7 of “Selecting Embroidery Patterns” on page 134.

Selecting Buttonhole/Eyelet Patterns

- 1 Touch .
- 2 Select a pattern, and then touch   to change the size.

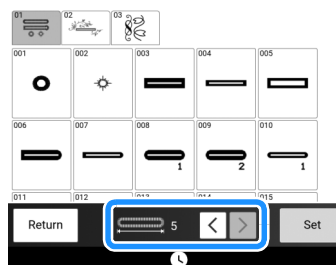

Selecting Alphabet Character Patterns

- 1 Touch **A**.
- 2 Touch the key of the font you want to embroider.

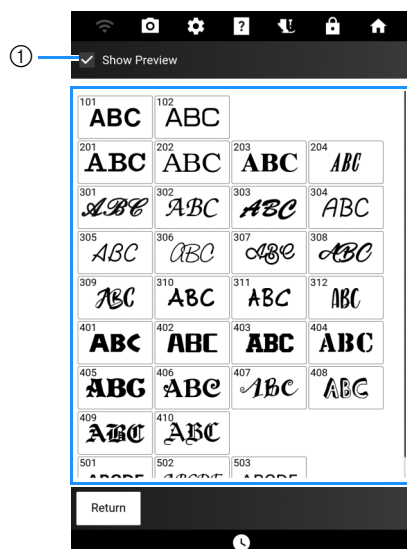

- 1 If the check box is selected, a preview of all characters will appear after the font has been selected.

- 3 If a preview of the characters is displayed, confirm that it is the desired font, and then touch [OK].

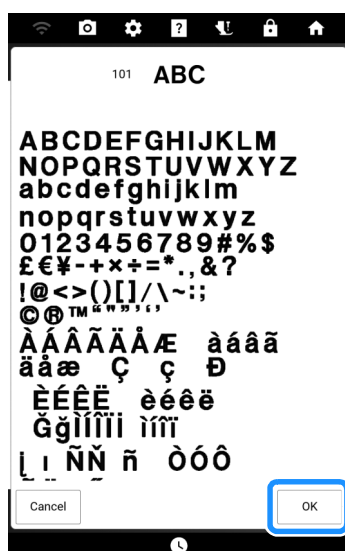

- 4 Specify the size of the characters to be entered. Select the character category and then type in the text.



- 1 Change the font of the characters.
- 2 Specify the character size.
- 3 Move the cursor and select a character. (page 138)
- 4 Switch between selecting multiple characters or selecting a single character. (page 138)
- 5 Delete the character.
- 6 Add a line.
- 7 Enter a space.
- 8 Align the characters at the right, left or center. (page 138)
- 9 Change the spacing of the character patterns. (page 144)
- 10 Change the configuration of the character patterns. (page 144)

Memo

- When entering text, the cursor is positioned after the last character entered. If the font or character size setting is changed, the new setting will be applied starting with the next character entered.

ABC ①

- 1 Cursor

- By selecting characters that have already been entered, you can change the font and character size. Refer to "Selecting Entered Characters" on page 138.

- 5 Touch [Set].
- 6 Follow steps 4 through 7 of "Selecting Embroidery Patterns" on page 134.

■ Selecting Entered Characters

In order to change the font or size of entered characters, those characters must be selected.

□ Selecting a Single Character

In single character selection mode (ABC A), touch < > to select the character to be changed.



① Selected character

□ Selecting Multiple Characters

In multiple character selection mode (ABC A), all characters will be selected.

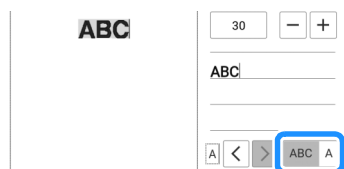

To deselect a character, touch it.



① Deselected character

■ Adding a New Line of Text

Note

- Add new lines and change the arrangement of the text when entering characters. No changes can be made after [Set] has been touched.

1 Type in the first line of characters, and

then touch .

2 Type in the second line of characters, and then touch . Type in the third line of characters.





Note

- In multiple character selection mode (ABC A) with multiple lines of text, all characters in one line will be selected. To select characters in a different line of text, touch that line.



3 Touch to change the text alignment.

 : Right alignment

 : Left alignment

ABCDE
FGH
IJKLMNOP

ABCDE
FGH
IJKLMNOP

 : Center alignment

ABCDE
FGH
IJKLMNOP

Confirming the Pattern Position

Memo

- The pattern can be projected onto the fabric in order to check the position of and edit the pattern. (page 154)

Checking the Needle Drop Point with the Projector

With the projector pointer, you can check the needle drop point before embroidering.

1 Touch in the embroidery screen.



→ The pointer of the projector indicates the needle drop point onto the fabric.

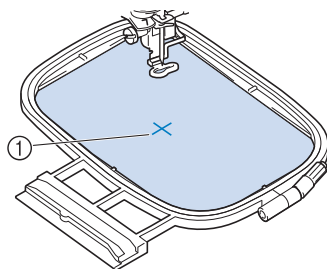

① Needle drop point

Memo

- The color and shape of the pointer can be changed in the settings screen.



Note

- With fabric that has a very uneven surface such as thick fabric or quilting, the fabric thickness may not be correctly measured. In this case, the pointer indication should be used only as a reference.

Checking the Pattern Position

The carriage moves and shows the pattern position. Watch the embroidery frame closely to make sure the pattern will be embroidered in the right place.

1 Touch .

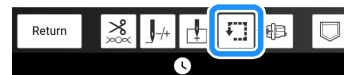

2 Touch the key for the position that you want to check.

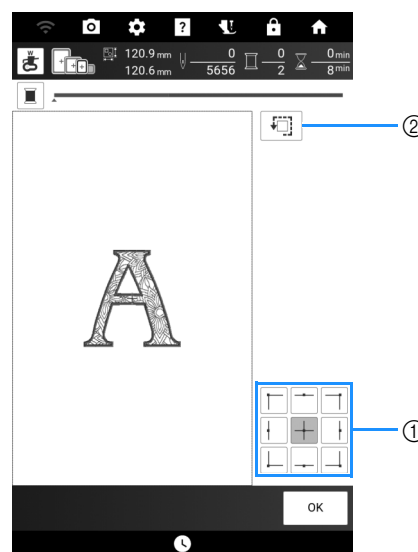

① Touch to check the selected position.

② Touch to check the entire embroidering area.

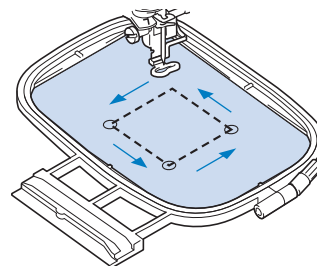

→ The carriage will move to show the pattern position.

Memo

- Touch  so that the pointer of the projector indicates the needle drop point onto the fabric.

CAUTION

- Do not lower the needle when the embroidery frame is moving. If the needle is down, it could break and result in injury.

3 Touch [OK].

Embroidering Patterns

- 1 Prepare embroidery thread colors as shown on the screen.

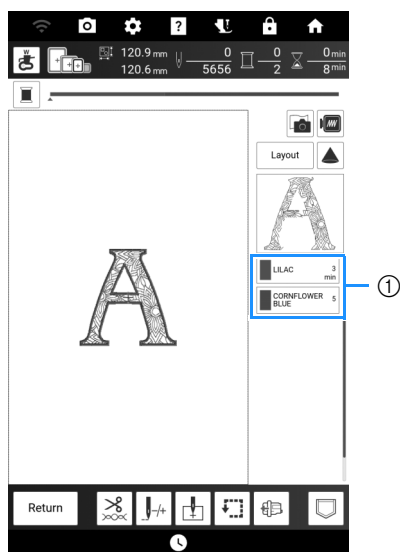

① Embroidery color order

Memo

- Either the thread color name or the thread number appears in this screen, depending on the setting selected in the settings screen. You can also select a thread brand. (page 25)

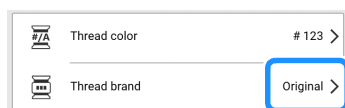

- The automatic thread cutting function and the thread trimming function can be used. (page 141)

- 2 Using the automatic needle threader, thread the machine for the first color.

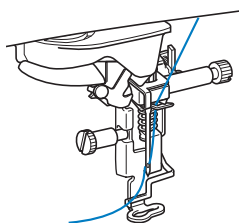

- 3 Lower the embroidery foot, then press the “Start/Stop” button to start embroidering.

→ When the first color is completely embroidered, the machine will stop.
On the embroidery color order display, the next color will move to the top.

Memo

- A setting in the settings screen can be specified so that pressing the “Start/Stop” button before starting embroidering automatically lowers the embroidery foot. (page 25)



- If you want to get more attractive finishes, try the procedures below;
 - After 5-6 stitches, press the “Start/Stop” button again to stop the machine.
 - Trim the excess thread at the beginning of embroidering. If the thread at the beginning of embroidering is under the embroidery foot, raise the embroidery foot, then trim the excess thread.

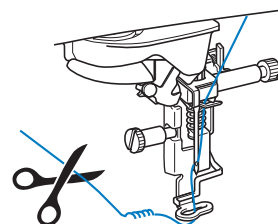

- If there is thread left over from the beginning of embroidering, it may be embroidered over as you continue embroidering the pattern, making it very difficult to deal with the thread after the pattern is finished. Trim the threads at the beginning of each thread change.

- 4 Remove the thread for the first color from the machine. Thread the machine with the next color.

5 Repeat the same steps for embroidering the remaining colors.

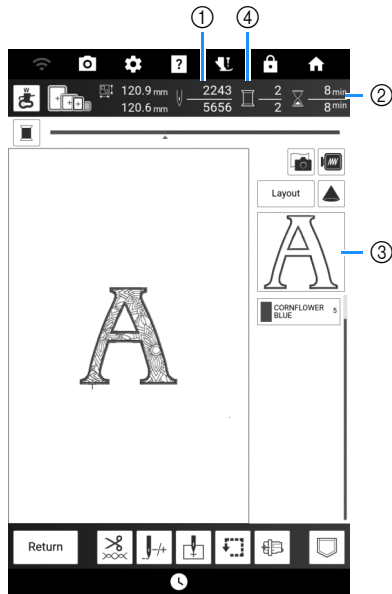

- ① Current stitch numbers/Total stitch numbers
 - ② Current time/Total time
 - ③ The part of pattern to be embroidered next
 - ④ Embroidered colors/Total colors
- When the last color is embroidered, [Finished embroidering.] will appear on the display. Touch [OK], and the display will return to the original screen.

6 Cut the excess thread jumps within the color, if necessary.

Thread Cutting/Trimming Function

The automatic thread cutting function (End Color Trim)  will cut the thread at the end of embroidering each color.

The thread trimming function (Jump Stitch Trim)  will automatically trim any excess thread jumps within the color. These functions are initially turned on.

ABCDEF

①

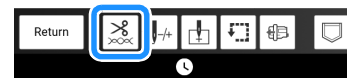

- ① Jump stitch

1 On the embroidery screen, touch .

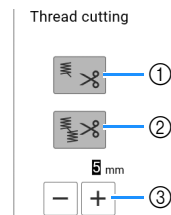

2 Turn on or off the thread cutting/trimming function.



- ① Turn on or off the automatic thread cutting function (End Color Trim).
- ② Turn on or off the thread trimming function (Jump Stitch Trim).
- ③ Touch  or  to select the length of jump stitch. For example, when the value is set to 25 mm (approx. 1 inch) and the machine will not trim a jump stitch of 25 mm or less before moving to the next stitching.

Memo

- If design has many trims, it is recommended to select a higher jump stitch trim setting in order to reduce the amount of excess tails on backside of fabric.
- The higher number of the jump stitch length selected, the fewer number of times the machine will trim. In this case, more jump stitches remain on the surface of the fabric.

Key Functions (Embroidery)

Embroidery Edit Screen

Using these keys, you can edit the pattern as you like.

Memo

- If a key display is grayed out, you cannot use that function with the selected pattern.

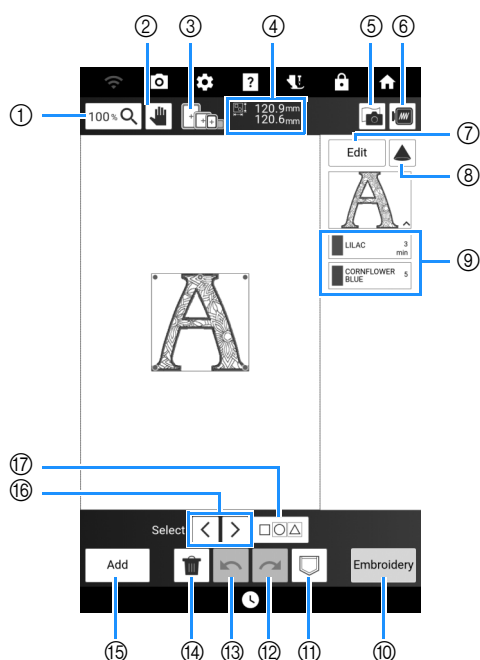

No.	Display	Explanation	Reference
	Name		
①		Touch this key to select the magnification ratio.	—
	Magnify key		
②		Touch this key to move the canvas when it is magnified.	—
	Hand tool key		
③		Shows the embroidery frames that can be used for the selected pattern.	128
	Available embroidery frames		
④		This shows the size of the entire combined pattern.	—
	Pattern size		
⑤		Touch this key to scan the fabric to align the embroidery position.	157
	Fabric scan key		
⑥		Touch this key for a preview of the embroidered image.	153
	Preview key		
⑦		Touch this key to display the [Edit] window.	143
	Edit key		

No.	Display	Explanation	Reference
	Name		
⑧		Touch this key to use the projector to project the pattern.	154
	Projector key		
⑨		This shows the color sequence and stitching times of each step of the pattern currently selected.	140
	Thread color sequence		
⑩		Touch this key to call up the embroidery screen.	—
	Embroidery key		
⑪		Touch this key to save a pattern in the machine's memory or USB media. The pattern can also be transferred to a computer via a wireless network connection.	167
	Memory key		
⑫		Touch this key to redo the last operation that was undone.	—
	Redo key		
⑬		Touch this key to undo the last operation.	—
	Undo key		
⑭		Touch this key to delete the selected pattern (the pattern outlined by the red box).	—
	Delete key		
⑮		Touch this key to add another pattern to the editing pattern.	147
	Add key		
⑯		Touch this key to change a selected pattern when multiple patterns are in the screen.	147
	Select key		
⑰		Touch this key to allow multiple patterns on the screen to be selected at the same time.	148, 149
	Multiple selection key		

■ [Edit] Window

Touch [Edit] to display the [Edit] window.

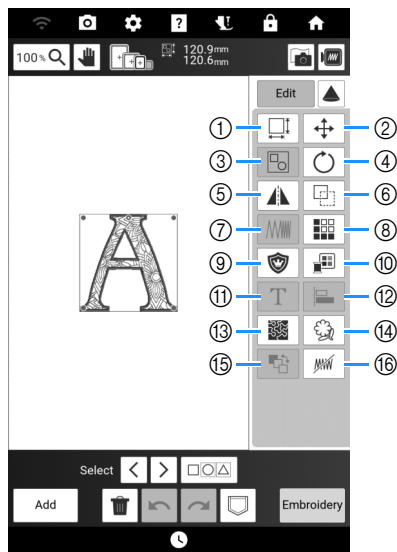

No.	Display	Explanation	Reference
	Name		
①		Touch this key to change the size of the pattern.	146
	Size key		
②		Touch this key to display the pattern moving window. <ul style="list-style-type: none"> : Move the pattern in the direction shown by the arrow. : Center the pattern. 	—
	Move key		
③		Touch this key to group the selected multiple patterns.	—
	Group/ungroup key		
④		Touch this key to display the pattern rotating window. Select the key indicating the desired direction and angle for rotating the pattern. <ul style="list-style-type: none"> : Reset the rotation. : Move the pattern in the direction shown by the arrow. You can also rotate the pattern by dragging the red point at the corners of the pattern.	—
	Rotate key		
⑤		Touch this key to change the pattern to a horizontal mirror image.	—
	Flip Horizontal key		
⑥		Touch this key to duplicate the pattern.	—
	Duplicate key		

No.	Display	Explanation	Reference
	Name		
⑦		Touch this key to change the density. This setting is available for some alphabet character patterns, frame patterns and so on. Other patterns are available after enabling patterns to change the density. (page 146)	—
	Density key		
⑧		Touch this key to create and edit repeated patterns.	150
	Border function (Designing repeated patterns) key		
⑨		Touch this key to create an appliqué piece by embroidering an outline around the selected pattern.	184
	Appliqué piece key		
⑩		Touch this key to change the colors of the displayed pattern.	169
	Thread palette key		
⑪		Touch this key to edit character patterns.	144
	Edit character patterns key		
⑫		Touch this key to align the selected multiple patterns.	149
	Alignment key		
⑬		Touch this key to create stippling, echo quilting, or decorative fill around a pattern.	194
	Stippling key		
⑭		Touch this key to extract the outline of a pattern. The extracted pattern can be used with My Design Center.	249
	Outline extraction key		
⑮		Touch this key to change the embroidering order of combined patterns.	172
	Embroidering order key		
⑯		Touch this key to specify not to embroider the selected thread color.	171
	No sew setting key		

Character Pattern Editing Screen

Even after text has been entered, the characters can be re-edited. Touch **T** in the [Edit] window to display the following screen.

Memo

- If a key display is grayed out, you cannot use that function with the selected pattern.
- Line feed key (⑦) and alignment key (⑩) cannot be used when re-editing character patterns.

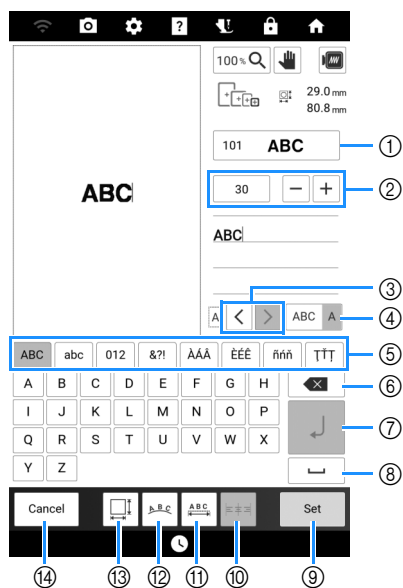

No.	Display	Explanation	Reference
	Name		
①	101 ABC	Change the font of the characters. Touch this key to display the available fonts.	—
	Font type key		
②	30 - +	Change the size of characters.	—
	Character size key		
③	< >	Move the cursor and select a character.	138
	Character selection keys		
④	ABC A	Switch between selecting multiple characters or selecting a single character. <ul style="list-style-type: none"> • ABC A : Multiple character selection mode • ABC A : Single character selection mode 	138
	Select multiple/one key		
⑤	—	Select the category of character.	—
⑥	✕	Delete the character.	—
	Delete key		
⑦	↵	Add a line. This function is available when entering characters.	138
	Line feed key		

No.	Display	Explanation	Reference
	Name		
⑧	␣	Enter a space.	—
	Space key		
⑨	Set	Apply the character pattern editing.	—
	Set key		
⑩	≡	Align the characters at the right, left or center. This function is available when multiple lines of characters are input.	138
	Alignment key		
⑪	ABC	Change the spacing of the character patterns. <ul style="list-style-type: none"> • +ABC+ : Increase the character spacing. • -ABC- : Decrease the character spacing. • The spacing between the selected character and the next character is changed. When the letter "D" is selected: <p>ABCD E ↔ ABCDE</p> <p>+ABC+ -ABC-</p> • When all characters are selected: <p>A B C D E ↔ ABCDE</p> <p>+ABC+ -ABC-</p> • ABC+ : Move the one selected character up. • ABC- : Move the one selected character down. • ABC : Reset the spacing. 	—
	Character spacing key		
⑫	ABC	Change the configuration of the character patterns. <ul style="list-style-type: none"> • To arrange the character patterns on an arc, touch <p>ABC, ABC, ABC or ABC.</p> <p>↶ : Make the arc flatter.</p> <p>↷ : Make the arc rounder.</p> • To arrange the character patterns on an incline, touch <p>ABC.</p> <p>↙ : Change the incline counterclockwise.</p> <p>↘ : Change the incline clockwise.</p> • ABC : Reset the layout. 	147
	Array key		
⑬	ABC	Change the character size for fine adjustment.	—
	Size key		
⑭	Cancel	Return to the previous screen.	—
	Cancel key		

Embroidery Screen

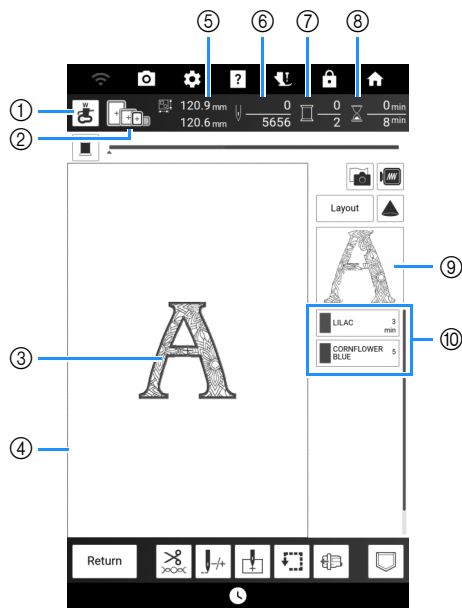

- ① Touch to check the needle drop point with the projector. (page 139)
 - ② Shows the embroidery frames that can be used for the selected pattern. Be sure to use the proper frame. (page 128)
 - ③ Shows a preview of the selected pattern.
 - ④ Shows the boundary for embroidering with the selected frame in the settings screen. (page 25)
 - ⑤ Shows the size of the selected pattern.
 - ⑥ Shows how many stitches are in the selected pattern and how many stitches have been embroidered so far.
 - ⑦ Shows the number of colors in the selected pattern and the number of the color currently being embroidered.
 - ⑧ Shows the time necessary to embroider the pattern and the time already spent embroidering the pattern (not including time for changing thread colors and automatically trimming the thread).
 - ⑨ Shows the part of the embroidery that will be embroidered with the first thread color.
 - ⑩ Shows the order for thread color changes and the embroidering time for each thread color.
- * The displayed time is the approximate time that will be required. The actual embroidering time may be longer than the displayed time, depending on the embroidery frame that is used. In addition, the amount of time required to change thread colors is not included.

[Layout] Window



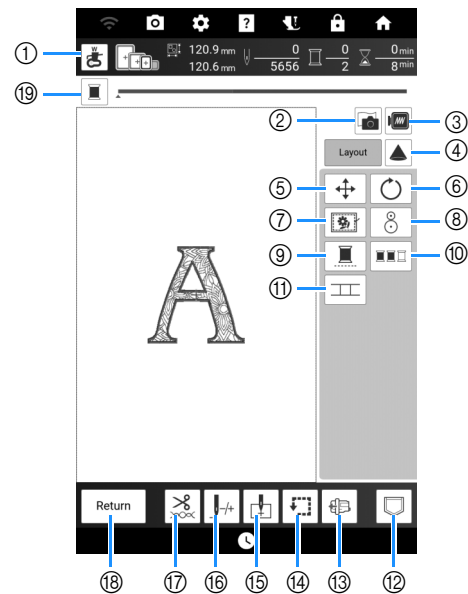





Touch [Layout] to display the [Layout] window.



Memo

- Some operations or functions are not available for certain patterns. If the key appears in light gray, you cannot use that function or operation with the selected pattern.

No.	Display	Explanation	Reference
	Name		
①		Touch this key to check the needle drop point with the projector.	139
	Needle point check key		
②		Touch this key to scan the fabric to align the embroidery position.	157
	Fabric scan key		
③		Touch this key for a preview of the embroidered image.	153
	Preview key		
④		Touch this key to use the projector to project the pattern.	154
	Projector key		
⑤		Touch this key to display the pattern moving window.	—
	Move key		
⑥		Touch this key to display the pattern rotating window.	—
	Rotate key		
⑦		Touch this key to add the basting stitch to the pattern. You can set the desired basting distance.	173
	Basting key		
⑧		Touch this key to align the embroidering position using the built-in camera and embroidery positioning sticker.	159
	Embroidery positioning key		
⑨		Touch this key to embroider the selected pattern with a single color (monochrome).	171
	Uninterrupted embroidery key		

No.	Display	Explanation	Reference
	Name		
⑩		Touch this key to reduce the number of thread color changes by rearranging the embroidering order for the selected pattern to combine parts of the same thread color.	170
	Color sorting key		
⑪		Touch this key to start pattern connecting embroidering. You can connect the patterns accurately using the built-in camera.	217
	Pattern connect key		
⑫		Touch this key to save a pattern in the machine's memory or USB media. The pattern can also be transferred to a computer via a wireless network connection.	167
	Memory key		
⑬		Position the carriage so the embroidery frame can easily be removed or attached.	164
	Frame move key		
⑭		Touch this key to check the position of the pattern. The carriage moves to the desired position so you can check that there is enough space to embroider the pattern.	139
	Trace area key		
⑮		Touch this key to move the needle start position to align the needle with the pattern position.	160, 174
	Starting point key		
⑯		Touch this key to move the needle forward or back in the pattern; useful if the thread breaks while embroidering or if you want to start again from the beginning.	163
	Forward/Back key		
⑰		Touch this key to specify automatic thread cutting, thread trimming or the thread tension.	141, 165
	Cut/Tension key		
⑱	Return	Touch this key to return to the previous screen.	—
	Return key		
⑲		Touch this key to switch the progress bar (which shows the embroidering progress) between showing only one color or all colors.	—
	Progress bar switching key		

Editing Patterns

Changing the Size of the Pattern

- 1 Touch [Edit], and then touch .

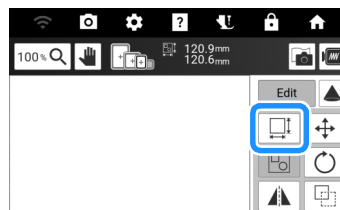

- 2 Select the size changing method.

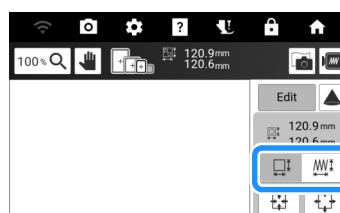



Change the pattern size while maintaining the number of stitches. Enlarged patterns will be less dense, and reduced patterns will be more dense. In order to maintain embroidering quality, there is a limit to how much the embroidery pattern can be enlarged or reduced.



With this function, the pattern will be enlarged or reduced at a larger ratio than with normal pattern resizing. Change the pattern size while maintaining the thread density. The number of stitches is recalculated depending on the pattern size. If this key appears in light gray and is not available, this function cannot be used with the selected pattern. When making a border pattern, change the size using this function and then apply the border setting.

Memo

- After the pattern size is changed using  , the thread density can be changed in the embroidery edit screen. (page 143)
- If the pattern is enlarged and there is space between stitches, a better effect can be achieved by increasing the thread density.
- If the pattern is reduced and the stitching is too thick, a better effect can be achieved by reducing the thread density.

3 Select the direction in which to change the size.

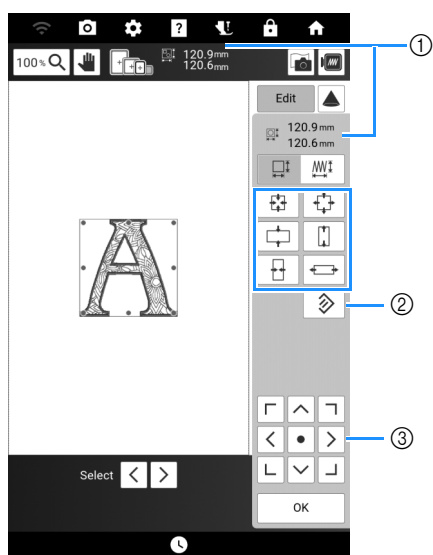

- ① Size of the pattern
- ② Touch to return the pattern to its original size.
- ③ Touch to move patterns.

	Decrease the pattern proportionately.
	Decrease the pattern vertically.
	Decrease the pattern horizontally.
	Enlarge the pattern proportionately.
	Stretch the pattern vertically.
	Stretch the pattern horizontally.

Memo

- Each pattern's range of size adjustment depends upon the original size of the design and the maximum embroidery area.
- Some patterns or characters can be enlarged to a greater degree if they are rotated 90 degrees.
- You can also change the pattern size by dragging the red point on the pattern image.

4 Touch [OK].

Note

- Be sure to do trial embroidery using same fabric and threads as project in order to check the embroidering results.

Combining Patterns

Example:



- 1** Select a pattern and then touch [Set].
- 2** Touch [Add].

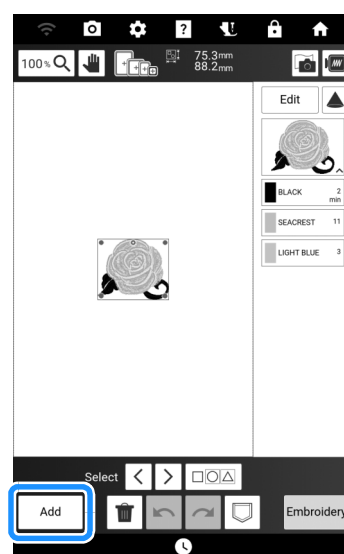

- 3** Touch **A A**.
- 4** Touch the key of the font and then type in the text. (page 137)

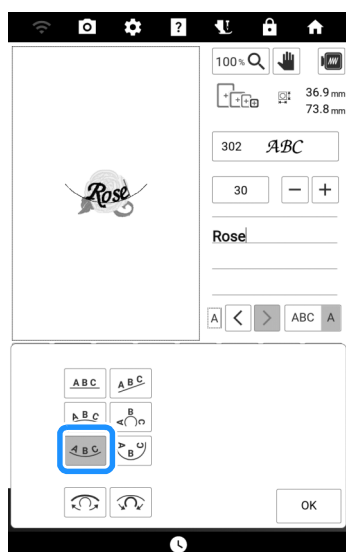

→ The characters you enter will be displayed in the center of the display.

5 Touch  to change the layout of the characters. Touch [OK].



* Refer to page 144 for more information about changing the layout.



6 Touch [Set] and then touch [Edit].

7 Touch  and then use  to move the characters. Touch [OK].

* Patterns can also be moved by directly dragging them with your finger or the included dual purpose stylus.

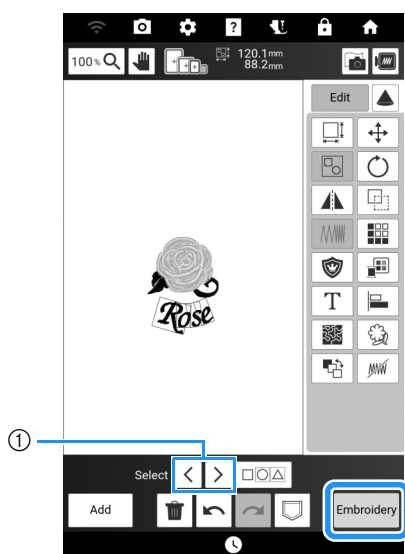
8 When all editing is finished, touch [Embroidery].



① If editing the combined patterns, use   to select the pattern to be edited. Patterns can also be selected by directly touching the screen with your finger or the included dual purpose stylus.

 **Memo**

- Combined patterns will be embroidered in the order they were entered. You can change the embroidering order. (page 172)



Selecting Multiple Patterns at the Same Time

1 Touch .

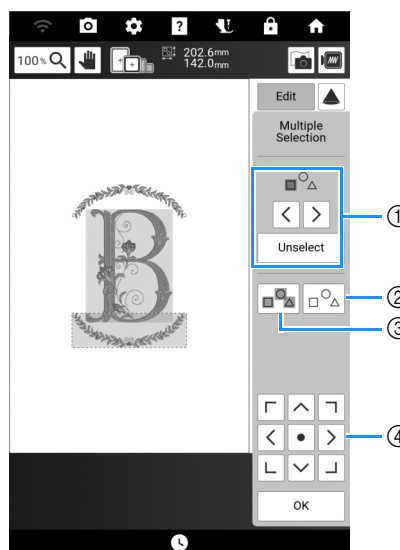

2 Touch each pattern to select multiple patterns.



- ① Touch  or  to check the patterns to be selected, and then touch [Select] to select the pattern. The selected patterns are surrounded with a red box. To deselect the selected patterns, touch [Unselect].
- ② Touch to deselect all selected patterns.
- ③ Touch to select all patterns in the pattern display area.
- ④ While the Multiple Selection screen is displayed, patterns can be moved with .

3 Touch [OK].

→ Each selected pattern is surrounded with a red box.

 **Memo**

- Some editing keys appear in light gray and are not available while multiple patterns are selected.

Grouping Multiple Selected Patterns

If the multiple patterns are grouped, they can be edited as a single pattern.

- 1 Touch .
- 2 Touch each pattern to select multiple patterns and then touch [OK]. (page 148)
- 3 Touch .

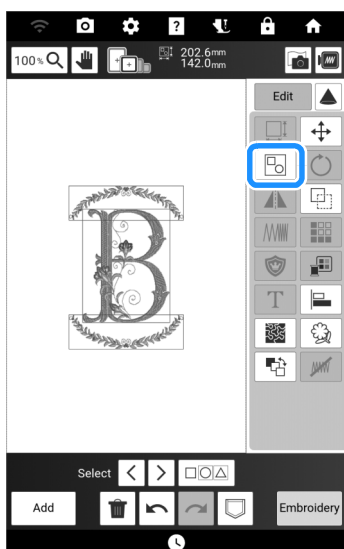

→ The selected patterns are grouped.

- * Touch  to ungroup the patterns. If there are multiple grouped patterns, the selected pattern group is ungrouped.

Memo

- Some editing keys appear in light gray and are not available while multiple patterns are grouped.

Aligning the Embroidery Patterns

- 1 Touch [Edit] and then touch .

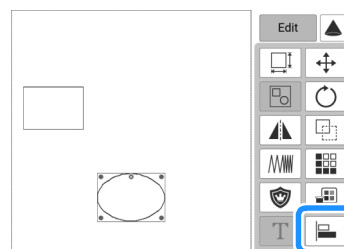

- 2 Touch each pattern that you want to align.

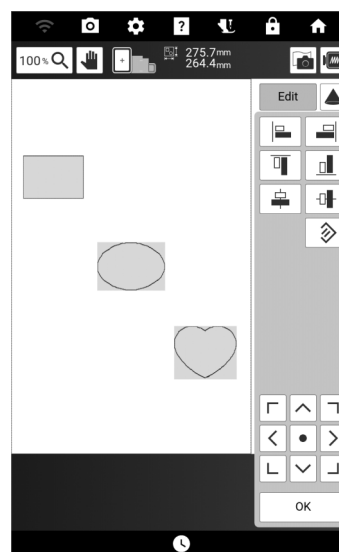

- 3 Touch the key for the desired alignment.

Example:

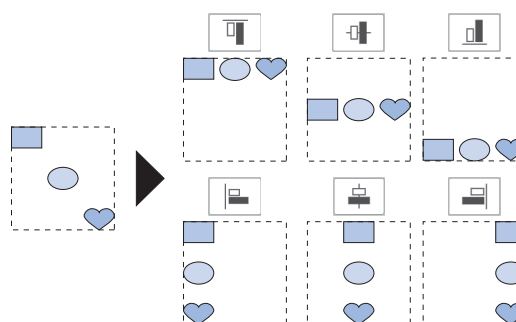

Designing Repeated Patterns

■ Creating Repeated Patterns

Using the border function, you can create repeated patterns.

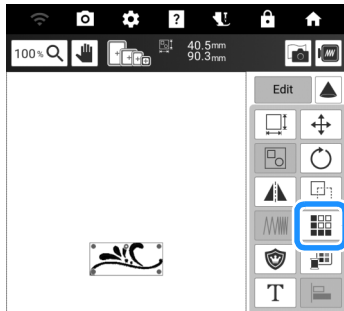

1 Touch [Edit], and then touch .



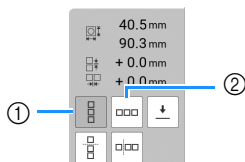

2 Select the direction in which the pattern will be repeated.



- ① Vertical direction
 - ② Horizontal direction (page 150)
- The pattern direction indicator will change depending on the direction selected.

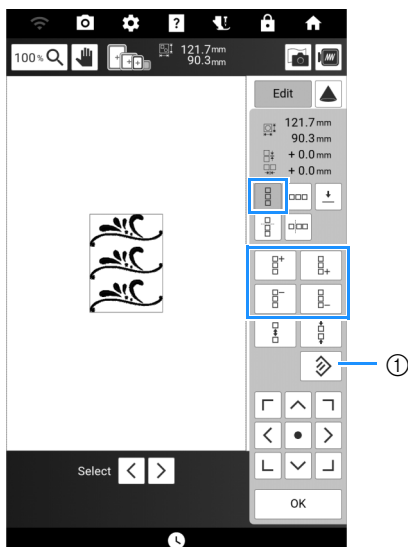

3 Use  to repeat the pattern above and  to repeat the pattern below.

- * To delete above pattern, touch .
- * To delete below pattern, touch .



- ① Key to cancel pattern repeating

4 Adjust the spacing of the repeated pattern.

- * To widen spacing, touch .
- * To tighten spacing, touch .

5 Complete repeated patterns by repeating steps 2 through 4.



6 Touch [OK].

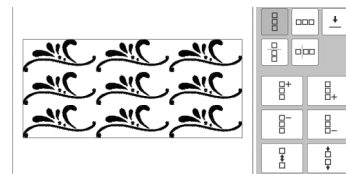

Memo

- When there are two or more patterns, all patterns will be grouped together as one pattern in the red frame.



■ Horizontal Direction

Use  to repeat the pattern to the left and  to repeat the pattern on the right.

- * To delete patterns from the left, touch .
- * To delete patterns from the right, touch .

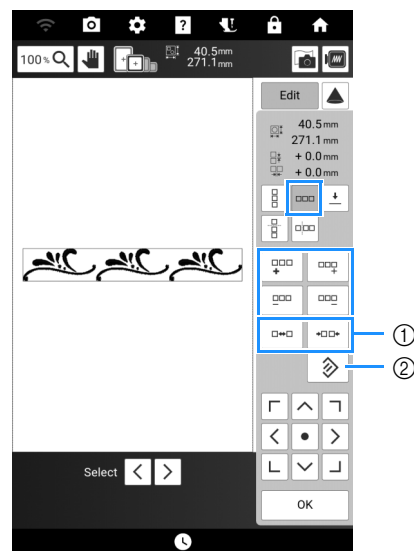

- ① Spacing keys
- ② Key to cancel pattern repeating

■ Repeating One Element of a Repeated Pattern

By using the Cut function, you can select one element of a repeated pattern and repeat only that single element.

- 1 Touch  and create repeated patterns. (page 150).
- 2 Choose the direction in which the repeated pattern will be cut.

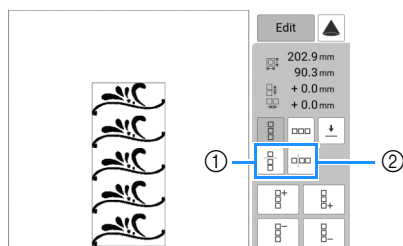

- ① Touch to cut horizontally.
 - ② Touch to cut vertically.
- The pattern direction indicator will change depending on the direction selected.

- 3 Use  and  to select the cut line. And then touch .

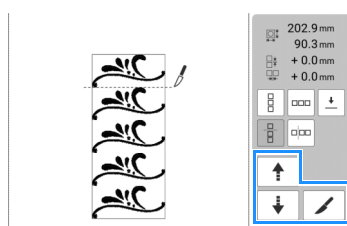

→ The repeated pattern will be divided into separate elements.

- 4 Touch .

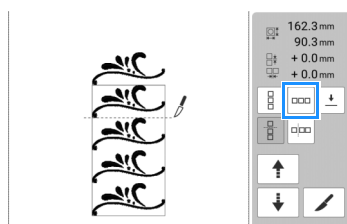

- 5 Use  and  to select the element to repeat.

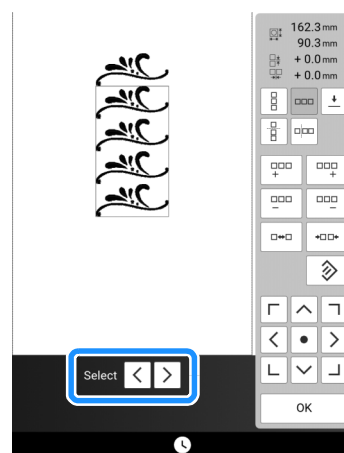

- 6 Repeat the selected element.

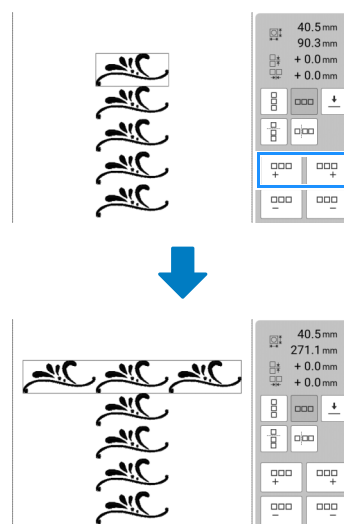

- 7 Touch [OK].

Memo

- Once you have cut a repeated pattern into separate elements, you cannot return to the original repeated pattern.

Embroidering the Pattern Repeatedly

By embroidering thread marks, you can easily align patterns when rehooping the fabric to embroider a series.



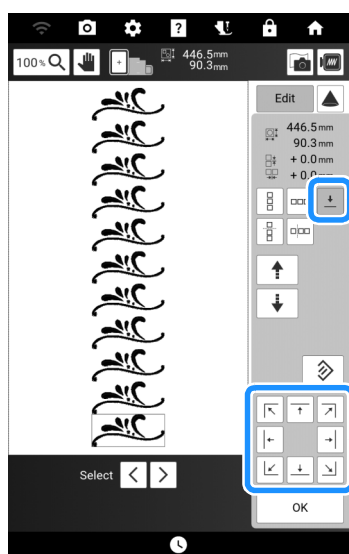

1 Touch [Edit], and then touch .

2 Touch .

3 Touch  to select the thread mark to be sewn.



Memo

- When there are two or more elements, use  and  or  and  to select a pattern that you want to assign a thread mark(s) to.

4 Touch [OK], then [Embroidery].

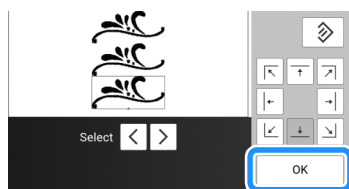

5 Press the “Start/Stop” button to begin embroidering.

→ When embroidering is finished, the thread mark is embroidered with the last thread color.



6 Remove the embroidery frame.

7 Rehoop the fabric in the embroidery frame.

Note

- Adjust the position of the fabric so that the embroidering area for the next pattern is within the embroidering area.

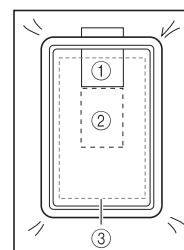

- ① Pattern embroidered first
- ② Position of pattern to be embroidered next
- ③ Embroidering area

8 Attach the embroidery frame to the machine, and then touch .

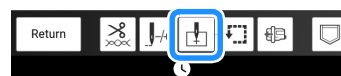

9 Touch  to set the starting point to the top center of the pattern.

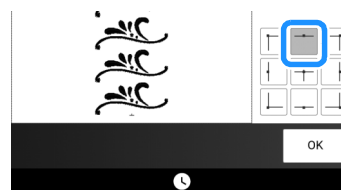

10 Touch [OK].

11 Press  (Presser foot lifter button) to lower the embroidery foot.

12 Touch .

13 Touch the positioning keys to move the embroidery frame until the thread mark on the fabric is aligned on the starting point in the camera view window.

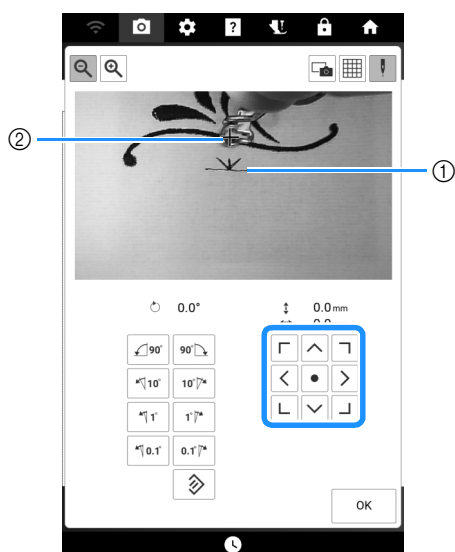

- ① Thread mark on the fabric
- ② Starting point



Note

- If the pattern position cannot be aligned using the positioning keys, rehoop the fabric, and then try again to align the position with the positioning keys.
- When embroidering the repeated pattern, do not rotate the pattern in the camera view window. If the pattern is rotated in the camera view window, you cannot embroider the pattern properly aligned even if the thread mark and the starting point are aligned in the camera view window.

14 Touch [OK] to return to the previous screen.

15 If necessary, remove the thread mark.

16 Press the “Start/Stop” button to begin embroidering.

Previewing the Pattern

1 Touch .

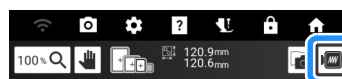

→ An image of the pattern as it will be embroidered appears.

2 Touch  to select the embroidery frame used in the preview.

* Embroidery frames displayed in light gray cannot be selected.

* Touch  to enlarge the image of the pattern.



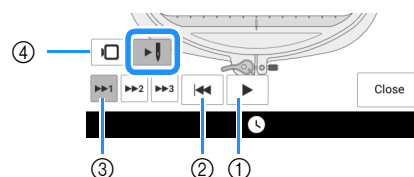

3 Touch  to check the embroidering order.

→ The stitch simulator screen appears.



① Play/Pause

When touching , icon changes to .



② Return to beginning.

③ Select the simulation speed.

④ Touch  to return to the embroidery frame selection screen.

Checking/Editing the Embroidery Pattern Projected Onto Fabric

Checking the Embroidery Pattern with the Projector

Using the projector, the selected embroidery pattern can be projected onto the fabric.

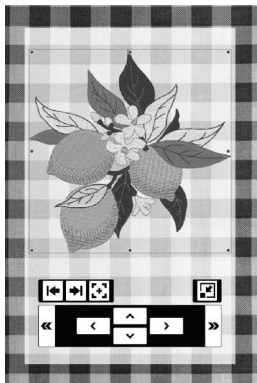
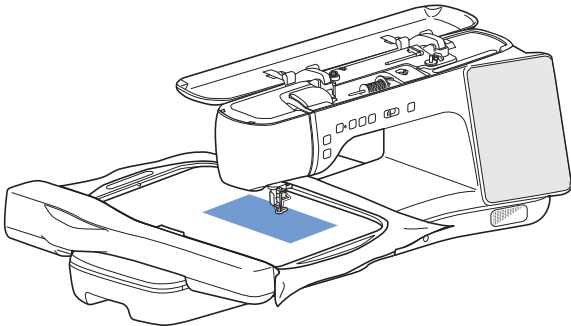

Memo

- The illustrations of the projections shown in this manual are for illustrative purposes only and may differ from the actual projections.

1 Make sure that the embroidery frame is attached to the machine, and then touch  in the following screens.

- Embroidery edit screen
- Embroidery screen
- Stitch settings screen of My Design Center

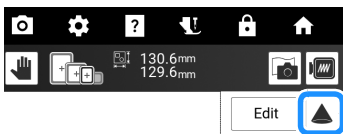

→ If a message appears, warning that the carriage will be moved, touch [OK].
The embroidery pattern is projected onto the fabric.

2 Check the embroidery pattern projected onto the fabric. If necessary, from the screen of the machine, change the location of the projection area on the fabric and the projector settings.

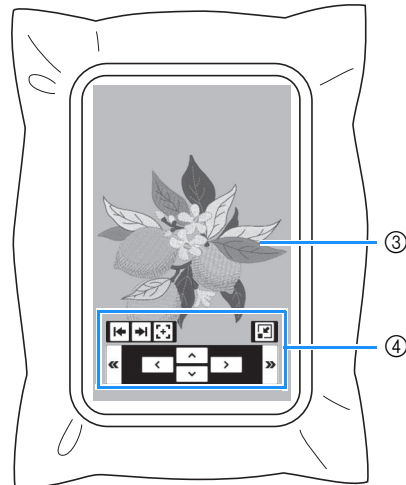
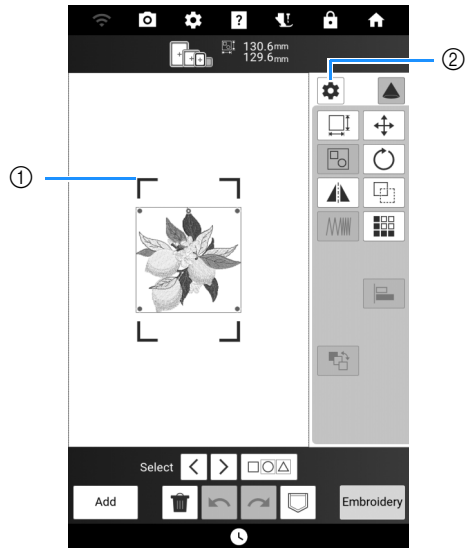

- ① Drag a blue line at one of the four corners to move the embroidery frame and change the location of the projection area on the fabric.
- ② Touch to display the following screen.

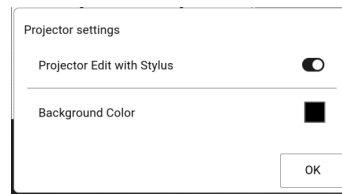

The function [Projector Edit with Stylus], which projects editing keys onto the fabric, can be switched on or off.
With [Background Color], the background color of the projector can be selected.

- ③ Embroidery pattern projected by the projector
- ④ Editing keys for operating with the dual purpose stylus. (page 155)

3 If necessary, edit the pattern.

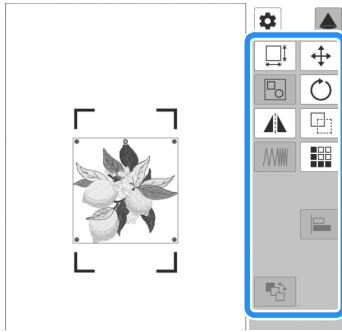

Memo

- Editing keys that are not displayed cannot be used with this function. To use all editing functions, touch to turn off projection. For details on each key, refer to “[Edit] Window” on page 143 or “[Layout] Window” on page 145.

4 After confirming the embroidery pattern, touch to turn off projection.

Using the Dual Purpose Stylus To Edit the Embroidery Pattern Projected Onto Fabric (Projector Edit with Stylus)

From the embroidery edit screen or embroidery screen, you can project the embroidery pattern onto the fabric, then edit it.

Memo

- If an embroidery frame that does not support this function has been attached, a message appears. In that case, edit using the screen.

1 Prepare the dual purpose stylus.

* For details on how to use the dual purpose stylus, refer to “Operating the Projector with the Dual Purpose Stylus” on page 70.

2 Touch in the embroidery edit screen or embroidery screen. (page 154)

3 If necessary, press the button of the dual purpose stylus to turn on the light over the key to change the projection.

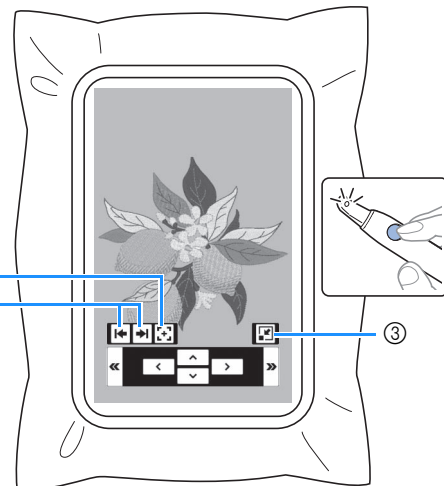
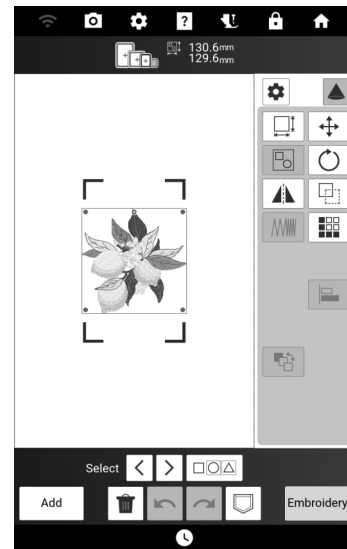

- ① Select whether to position the editing keys (projected by the projector) at the left, right or bottom.

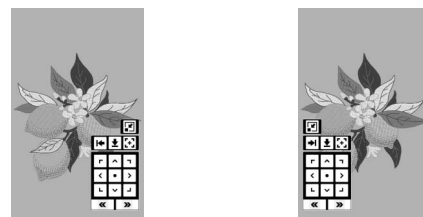

- ② Displays keys for changing the location of the projection area on the fabric. (page 156)
 ③ Minimizes the keys projected by the projector.



4 Press the button of the dual purpose stylus to turn on the light over « or » in order to edit the embroidery pattern.

- * The camera detects the light, and the embroidery pattern is edited as specified.
- * When finished editing, touch ▲ in the LCD screen to turn off projection.

■ Positioning Mode

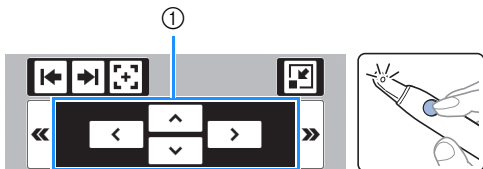

① Move the embroidery pattern.

■ Resizing Mode (Embroidery Edit Screen Only)

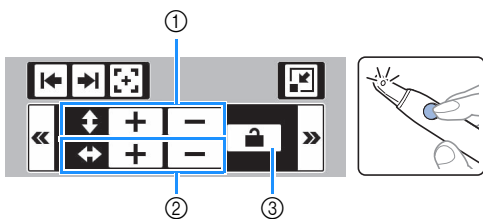

- ① Changes the height of the embroidery pattern.
- ② Changes the width of the embroidery pattern.
- ③ Locks/unlocks the aspect ratio.

■ Rotation Mode

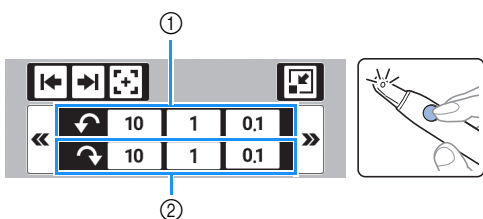

- ① Rotates the embroidery pattern counterclockwise.
- ② Rotates the embroidery pattern clockwise.

■ Changing the Location of the Projection Area

1 Make sure that the embroidery frame is attached to the machine, and then touch ▲ in the following screens.

- Embroidery edit screen
- Embroidery screen
- Stitch settings screen of My Design Center

2 If ▲ was touched in the embroidery edit screen or embroidery screen, place the point of the dual purpose stylus over [↔], and then press the button to turn on the light.

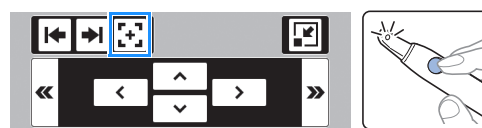

3 Place the point of the dual purpose stylus over a key in [⬆️⬇️⬇️⬆️], and then press the button to turn on the light.

over a key in [⬆️⬇️⬇️⬆️], and then press the button to turn on the light.

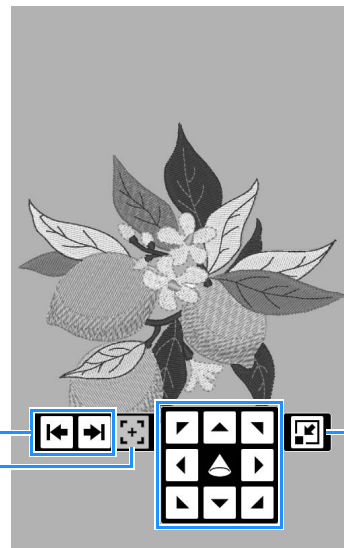

- ① Select whether to position the keys (projected by the projector) at the left, right or bottom.
- ② Switches the projection to edit mode (embroidery edit screen and embroidery screen only). (page 155)
- ③ Minimizes the keys projected by the projector.
→ The camera detects the light of the dual purpose stylus, and the location of the embroidery pattern projection area is changed as specified.

4 After confirming the settings, touch ▲ in the LCD screen to turn off projection.

Align the Embroidering Position

Display the Fabric on the Screen

The fabric hooped in the embroidery frame can be displayed on the screen so that the embroidery position can be easily aligned.

Example:

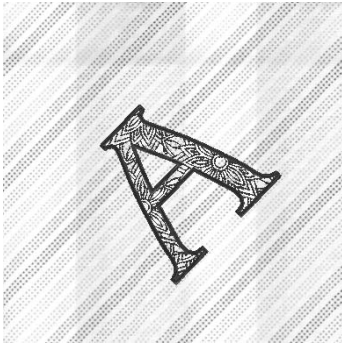

Memo

- When embroidery frame (20 mm (H) × 60 mm (W) (approx. 1 inch (H) × 2-1/2 (W) inches) is installed, this function cannot be used.
- For details on using thicker fabric such as quilting, refer to “Positioning the Pattern on Thick Fabric” on page 158.

- 1 Hoop the fabric in the embroidery frame, and then attach the frame to the machine.
- 2 Select the pattern and, if necessary, edit the pattern.
- 3 Touch .

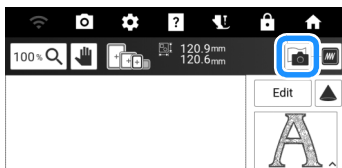

- 4 Touch [Scan].

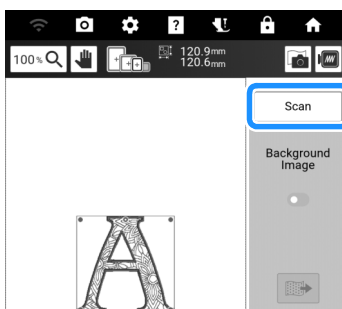

- 5 When the following message appears, touch [OK].

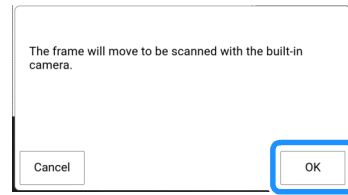

→ The carriage moves so the fabric can be scanned.

- 6 When the fabric appears as a background for the pattern, touch [Close].

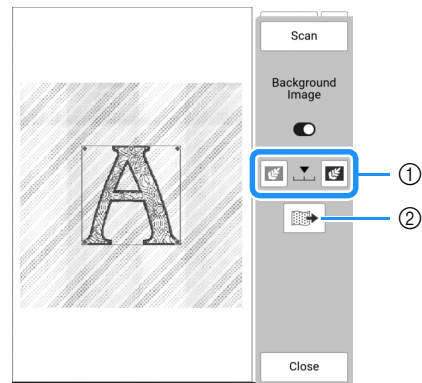

- ① The transparency of the scanned background image can be adjusted.
 - ② The background image can be saved to USB media.
- * If two USB media are connected to the machine, check the USB media names that are displayed, and then touch the name of the USB media that you wish to use.

7 Align the pattern to the desired embroidery position.

- * Refer to "Embroidery Edit Screen" on page 142 about the "Edit" display.

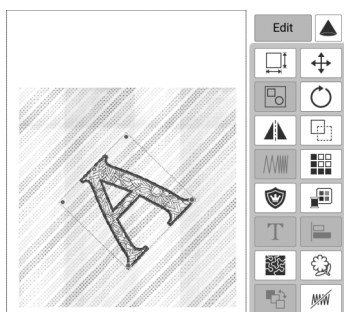

Memo

- The pattern can be moved to the desired position by dragging on the screen using your finger or the included dual purpose stylus pen. If you need some fine adjustment, touch  to move the pattern.

Note

- The fabric will appear in the background until embroidering of the pattern is finished. In order to show or hide the background image, touch , and then set [Background Image] to on or off.

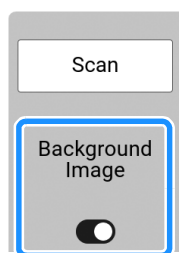

- With the settings screen, the quality of the background image can be set, or the scanned image can be deleted.

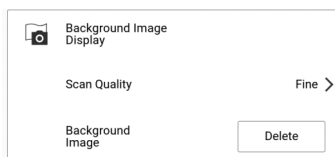



Positioning the Pattern on Thick Fabric

When positioning the pattern on thick fabric such as quilting, the fabric may not be detected correctly. In order for the fabric to be correctly detected, its thickness must first be measured.

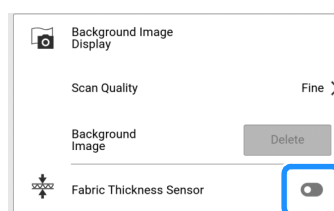
- 1 Hoop the fabric in the embroidery frame, and then attach the embroidery frame to the machine.
- 2 Select the pattern and, if necessary, edit the pattern.
- 3 Touch  to display [Fabric Thickness Sensor] of the settings screen and then set to on.



- 4 Touch [OK].
- 5 Touch .
- 6 Touch [Scan].
- 7 Affix the embroidery positioning sticker to the fabric within the area indicated by the red frame displayed with the projector, and then touch .

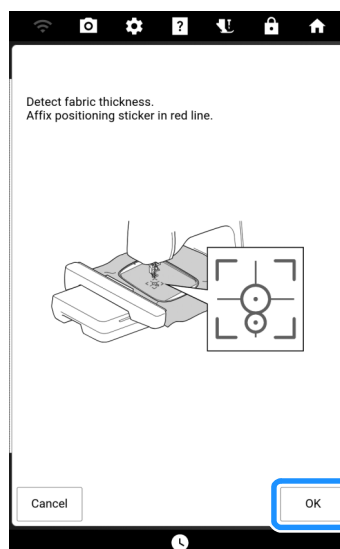

- 8** When the following message appears, remove the embroidery positioning sticker, and then touch [OK].

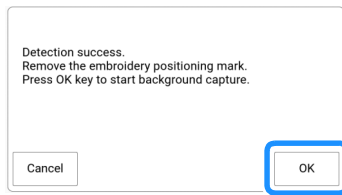

→ The carriage is moved, and the embroidery positioning sticker affixed to the fabric is detected.

- 9** Continue with step 6 of “Display the Fabric on the Screen” on page 157 to align the pattern with the desired embroidery position.

Using the Embroidery Positioning Sticker

The embroidering position can easily be aligned using the machine’s built-in camera and the included embroidery positioning sticker.

Note

- Before using the embroidery positioning sticker, check that it can be cleanly removed from a scrap piece of the fabric to be used.

- 1** Touch [Layout] to display the editing window, and then touch .

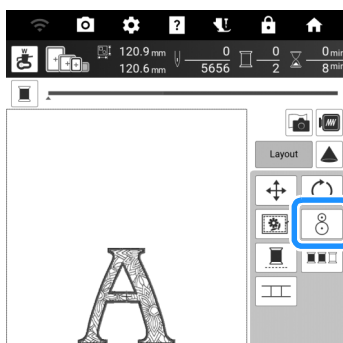

- 2** Following message appears. Touch [OK].

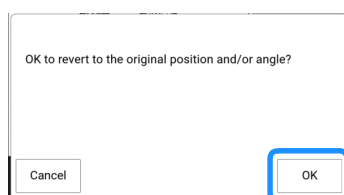

- 3** Select the position you want to set as the reference point.

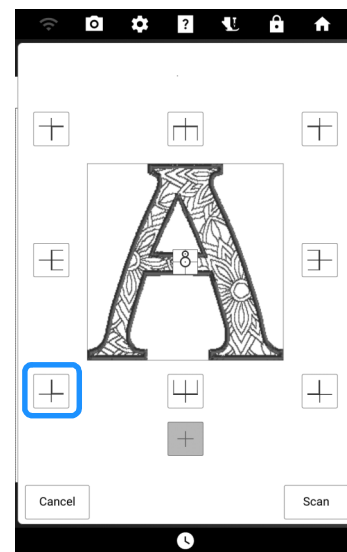

- * Select  if you want to embroider referring the embroidery positioning sticker as the center of the pattern.

- 4** Affix the embroidery positioning sticker to the location in the fabric to be embroidered. Place the embroidery positioning sticker so that the center of the larger circle is at the center or edge of the embroidery pattern.

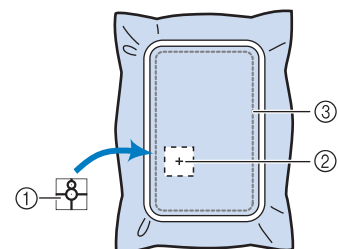

- ① Embroidery positioning sticker
- ② Center or edge of the embroidery pattern
- ③ Embroidery field

Memo

- Affix the embroidery positioning sticker so that the smaller circle is on top. The angle of the pattern depends on the angle at which the embroidery positioning sticker is affixed. In order to change the angle at which the pattern will be embroidered, affix the embroidery positioning sticker at the desired angle.

5 Touch [Scan].

* Attach embroidery foot "W" before touching [Scan].

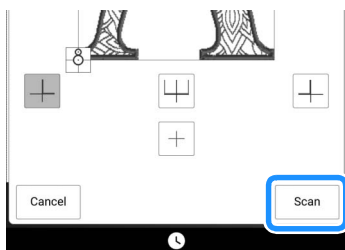

6 Following message appears. Touch [OK].

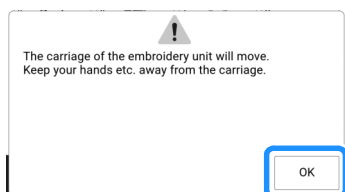

→ The built-in camera automatically searches for the embroidery positioning sticker, and then the carriage is moved so that the selected reference point of the embroidery pattern is aligned with the embroidery positioning sticker.

7 A reminder message appears. Remove the embroidery positioning sticker from the fabric, and touch [OK].

* To remove the embroidery positioning sticker more easily, touch  so that the carriage moves slightly forward and away from under the needle.

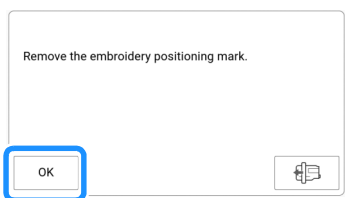
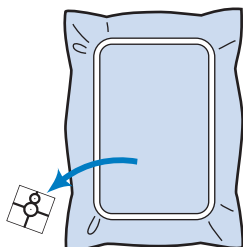

8 Press the "Start/Stop" button to begin embroidering.

Aligning the Pattern and the Needle

Example: Aligning the lower left side of a pattern and the needle.

1 Mark the embroidery start position on the fabric, as shown.

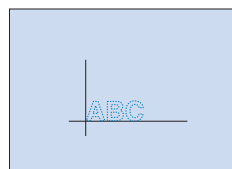

2 On the embroidery screen, touch .



3 Touch then touch [OK].

* When  is touched, the pointer of the projector indicates the needle drop point onto the fabric. (page 139)

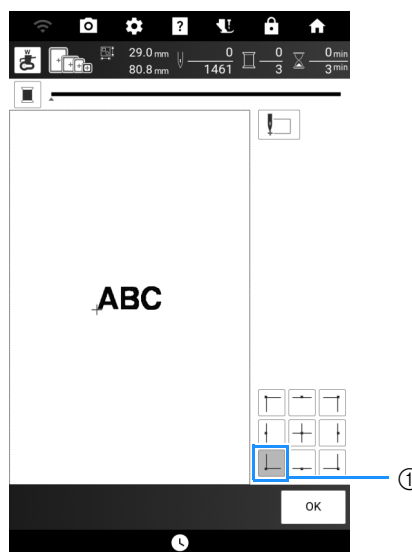

① Start position

→ The carriage will move to the specified needle position.

4 Touch [Layout], and then touch . And then align the needle and the mark on the fabric.

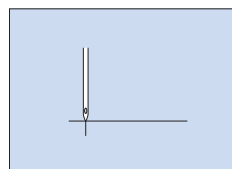

Using the Camera View Window

The camera built into this machine can be used to easily align the embroidering position.

- 1 Use a chalk pencil to draw a cross at the desired embroidering location. And then, hoop the fabric

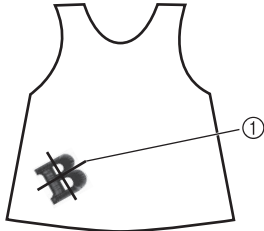

① Chalk pencil mark

- 2 Select the pattern on your machine and touch [Embroidery].

- 3 Touch  in the embroidery screen.



- 4 Touch  to set the starting point to the center of the pattern.

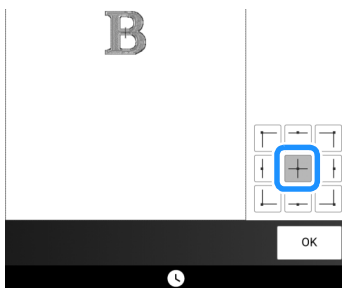

- 5 Touch [OK].

- 6 Press  (Presser foot lifter button) to lower the embroidery foot.

- 7 Touch .

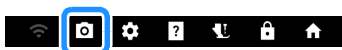

- 8 Touch the positioning keys to move the embroidery frame until the cross-shaped chalk mark drawn on the fabric is displayed in the camera view window.

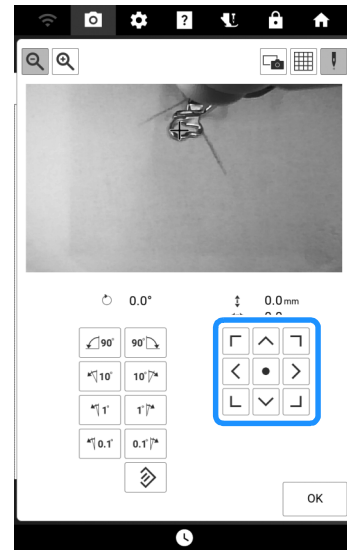

- 9 Touch  to display the grid lines.

- 10 Touch the orientation keys until the grid lines are parallel with the chalk mark drawn on the fabric.

- 11 Touch the positioning keys to move the embroidery frame until the center point of the pattern in the camera view window is aligned with the chalk mark drawn on the fabric.

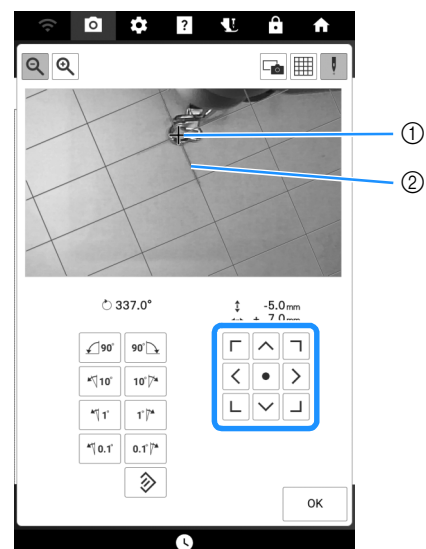

- ① Center point of the pattern
② Chalk mark

- 12 Touch [OK] to return to the previous screen.

Adjustments during the Embroidery Process

If the Bobbin Runs out of Thread

When the bobbin begins to run out of thread during embroidering, the machine will stop and the message below will appear.

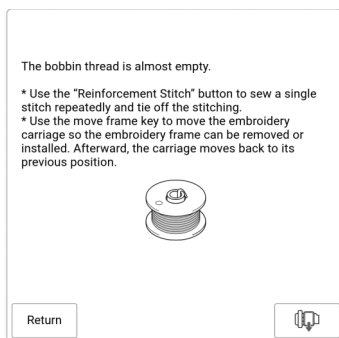

1 Leave the message displayed and then press  (Reinforcement stitch button) to sew reinforcement stitches to prevent stitches from unraveling.

2 Touch .

Memo

- If the message appears when only a few more stitches are necessary to complete embroidering, simply press the “Start/Stop” button, allowing about 10 more stitches to be embroidered.
- If [Upper and Bobbin Thread Sensor] in the settings screen is set to off, the message shown above does not appear.
- Touch [Return] to close the message.

3 Touch [OK].

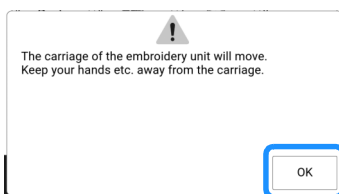

→ After the thread is automatically cut, the carriage will move.

4 Leave the message displayed and then continue with the next step.

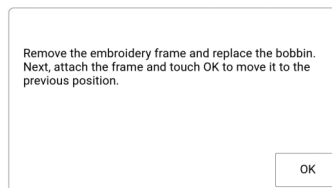

5 Unlock the frame-securing lever and remove the embroidery frame.

* Be careful not to apply strong force to the fabric at this time. Otherwise, the fabric may loosen in the embroidery frame.

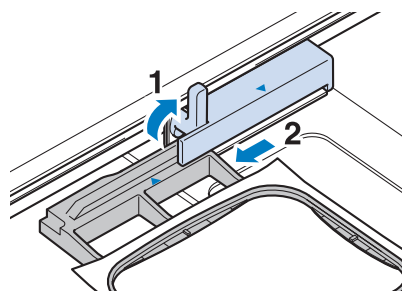

6 Insert a wound bobbin into the machine. (Refer to “Setting the Bobbin” on page 40.)

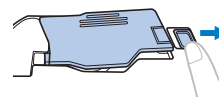

7 Attach the embroidery frame.

8 Touch [OK].

→ The carriage will move to its previous position.

9 Press  (Reinforcement stitch button) to sew reinforcement stitches at the beginning of sewing, and then press the “Start/Stop” button to continue embroidering.

If the Thread Breaks during Embroidering

- 1 If the upper thread is broken or runs out, redo the upper threading.

Memo

- If the bobbin thread is broken, follow the directions of "If the Bobbin Runs out of Thread" on page 162.

- 2 Touch .







- 3 Press  (Presser foot lifter button) to lower the embroidery foot.



- 4 Touch .





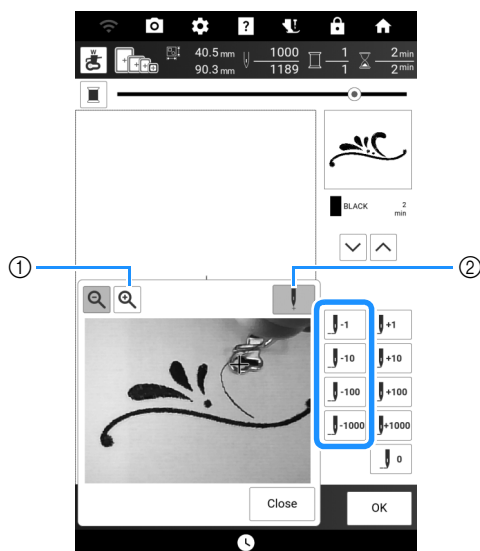



→ The camera view window appears.

- 5 Touch , , , or  to move the needle back the correct number of stitches before the spot where the thread broke.



- ① Touch  to enlarge the image in the screen.
- ② Touch  to remove " + " from the screen.

Memo

- If you cannot move back to the spot where the thread broke, touch  or  to select the color and move to the beginning position of that color, then use , , , or  to move ahead to slightly before where the thread broke.
- Touch  to restart from the beginning.

- 6 Touch [Close] and then touch [OK].

- 7 Press  (Reinforcement stitch button) to sew reinforcement stitches at the beginning of sewing, and then press the "Start/Stop" button to continue embroidering.

If It is Difficult to Thread the Needle or Remove the Embroidery Frame

Depending on the position of the embroidery frame, it may be difficult to thread the needle or remove the embroidery frame. If this happens, move the embroidery frame.

- 1 Touch  in the embroidery screen.



- 2 When a message appears, warning that the carriage will be moved, touch [OK].
→ The carriage moves. A message appears again.
- 3 Leave the message displayed, thread the needle or remove the embroidery frame.
- 4 Touch [OK].
→ The embroidery frame will be moved to its original position.

Resuming Embroidery after Turning Off the Power

Even if the power goes out in the middle of embroidery, the next time the machine is turned on, you have the option to continue or delete the pattern.

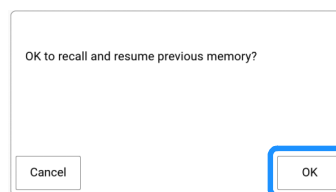

Note

- Do not remove the embroidery unit or the memory will no longer remember your design.
- If embroidery was interrupted before a color segment was completed, move the needle back to overlap the previous stitching by a few stitches to avoid unraveling. (page 163)

Adjusting Thread Tension

Adjusting the Tension of the Upper Thread

Adjust thread tension according to the situation.

Correct Thread Tension

Upper thread slightly appears on the wrong side of fabric.



① Right side
② Wrong side

Upper Thread is Too Tight

Bobbin thread appears slightly on the right side of fabric. In this case, loosen the upper thread tension.

Note

- If the bobbin thread was incorrectly threaded, the upper thread may appear to be too tight. In this case, refer to "Setting the Bobbin" on page 40 and rethread the bobbin thread.



① Right side
② Wrong side

Upper Thread is Too Loose

Loops appear on the right side of the fabric. In this case, tighten the upper thread tension.

Note

- If the upper thread was incorrectly threaded, the upper thread may appear to be too loose. In this case, refer to "Upper Threading" on page 42 and rethread the upper thread.





① Right side
② Wrong side

Adjusting the Tension of the Upper Thread

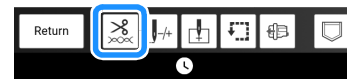
- On the embroidery screen, touch .



- Adjust the upper thread tension.

- Touch  to loosen the upper thread tension. (The tension number will decrease.)
- Touch  to tighten the upper thread tension. (The tension number will increase.)

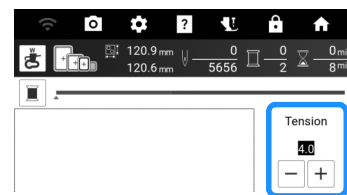

Note

- If the thread tension setting is made extremely loose, the machine may stop during embroidering. Increase the thread tension slightly, and begin embroidering again.

Adjusting Overall Upper Thread Tension

When embroidering, if the overall tension of the upper thread is too tight or too loose, adjust it from the setting screen.

If an individual embroidery pattern needs additional fine tuning, refer to "Adjusting Thread Tension" on page 165.

- Touch , and then touch .

- In the [Embroidery Tension], adjust the upper thread tension.

- Increase to tighten the upper thread tension.
- Decrease to loosen the upper thread tension.



Adjusting the Alternate Bobbin Case (with No Color on the Adjusting Screw)

To adjust the bobbin tension for embroidery function, using the alternate bobbin case (with no color on the screw), turn the slotted screw (-) with a (small) screwdriver.

Note

- The bobbin case that is used differs depending on the embroidery bobbin thread that is used. Only the alternate bobbin case allows the bobbin thread tension to be adjusted. For details, refer to “Embroidering Attractive Finishes” on page 132.

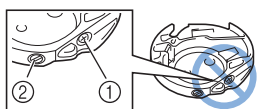

- Do not turn the phillips (+).
- Adjust with a screwdriver (small).

IMPORTANT

- Do not adjust the position of the phillips (+) screw on the alternate bobbin case as this may result in damage to the bobbin case, rendering it unusable.
- If the slotted screw (-) is difficult to turn, do not use force. Turning the screw too much or providing force in either (rotational) direction may cause damage to the bobbin case. Should damage occur, the bobbin case may not maintain proper tension.

Note

- When adjusting the alternate bobbin case, be sure to remove the bobbin from the alternate bobbin case.

Correct Tension

Upper thread slightly appears on the wrong side of fabric.

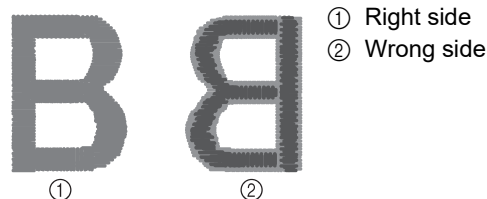

- * Light gray color represents upper thread.
- * Dark gray color represents bobbin thread.

Bobbin Thread is Too Loose

Bobbin thread appears slightly on the right side of fabric.

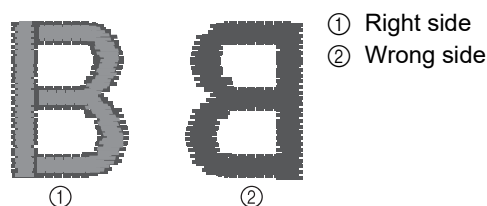

If this occurs, turn the slotted screw (-) clockwise, being careful not to over-tighten the screw, approximately 30-45 degrees to increase bobbin tension.

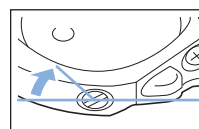

Bobbin Thread is Too Tight

Upper thread on the right side of fabric seems to be lifting/looping and bobbin thread is not seen on the wrong side of fabric.

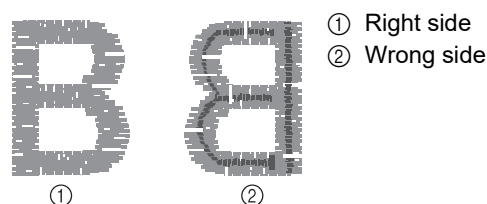

If this occurs, turn the slotted screw (-) counterclockwise, being careful not to over-loosen the screw, approximately 30-45 degrees to decrease bobbin tension.

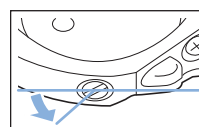

Using the Memory Function (Embroidery)

Memo

- For more information about the memory function, refer to “Specifications” on page 271.

Saving Embroidery Patterns

- 1 Touch  when the pattern you want to save is in the embroidery screen.

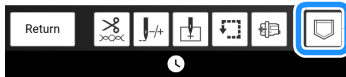

Memo

- You can also save the pattern by touching  in the embroidery edit screen.

- 2 When saving the embroidery pattern in a USB media, insert the USB media into the USB port on the machine.

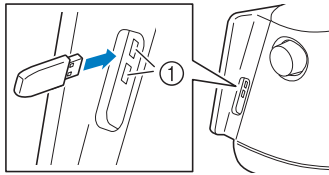

① USB ports

IMPORTANT

- Do not insert anything other than USB media into the USB media port. Otherwise, damage to the machine may result.

- 3 Select the destination to start saving.

- * If two USB media are connected to the machine, check the USB media names that are displayed, and then touch the name of the USB media that you wish to use.

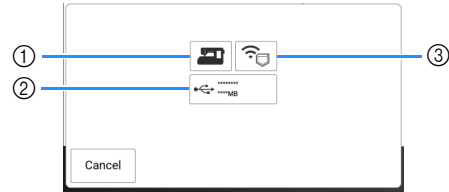

- ① Save to the machine's memory.
- ② Save to the USB media.
The pattern is saved in a folder labeled [bPocket].
- ③ Save to the wireless function pocket.
For the detailed procedure, refer to the manual for PE-DESIGN (version 11 or later).

Note

- Do not turn the main power to OFF while the [Saving...] screen is displayed. You will lose the pattern you are saving.

Retrieving Embroidery Patterns

1 When retrieving the embroidery pattern from a USB media, insert the USB media into the USB port on the machine.

* For details on supported file extensions, refer to "Specifications" on page 271.

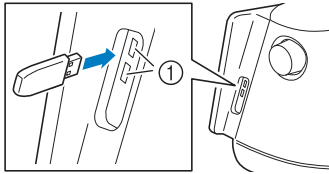

① USB ports

2 Touch .

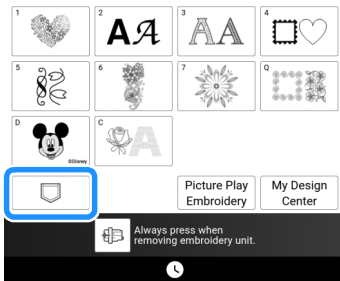

3 Touch the desired source.

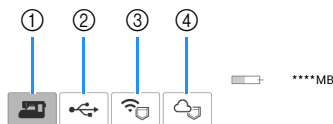

- ① Retrieve from the machine's memory.
- ② Retrieve from a USB media.
If two USB media are connected to the machine, check the USB media names that are displayed, and then touch the name of the USB media that you wish to use.
- ③ Retrieve embroidery patterns uploaded to the wireless function pocket via wireless network.
For the detailed procedure, refer to the manual for PE-DESIGN (version 11 or later) or Design Database Transfer.
- ④ Retrieve from Artspira App. (page 225)

Memo

- If the embroidery pattern to be retrieved is in a folder of the USB media, touch the key for that folder.

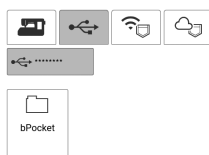

4 Touch the key of the pattern you want to retrieve.

* Touch  to return to the previous folder.

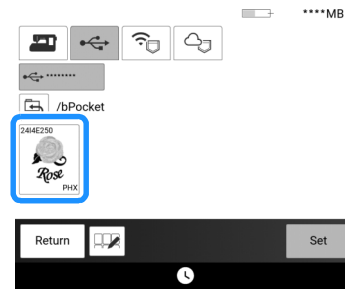

Memo

- By touching , the selected patterns can be deleted or saved to the machine's memory.

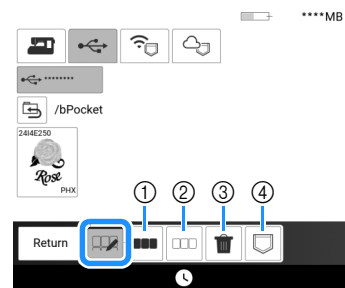

- ① Select all patterns.
- ② Deselect all patterns.
- ③ Delete the selected patterns.
- ④ Save the selected patterns to the machine.

5 Touch [Set].

Chapter 5 Advanced Embroidery

Editing Colors

Changing the Thread Color

- 1 Touch [Edit], and then touch .

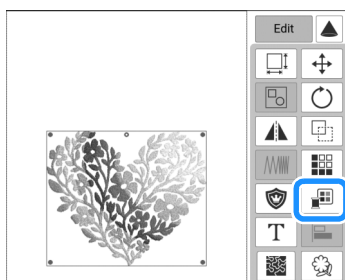

- 2 Touch the color of the part to be changed and then select a new color from the color palette.

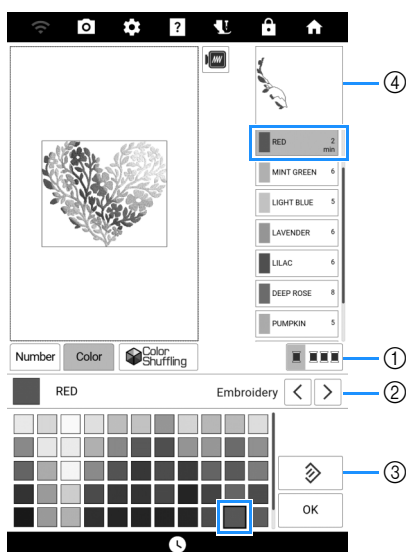

- ① Switch between selecting a single color and selecting all colors.
- ② Select the thread brand.
- ③ Revert to the original color.
- ④ Selected thread color image

Memo

- Touch [Number] to find a thread color by entering its number. If you enter the wrong number, touch [C].

- 3 Touch [OK].

Find New Color Schemes with the Color Shuffling Function

With the color shuffling function, the machine suggests new color schemes for the embroidery pattern that you have selected.

- 1 Touch [Edit], and then touch .

- 2 Touch .

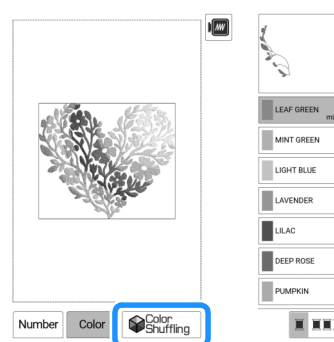

Memo

- This function may not be available depending on the pattern you select (ex. a bordered embroidery pattern, licensed pattern).

- 3 Select the thread brand for colors and the number of colors you want to create the pattern with. And then select the desired effect.

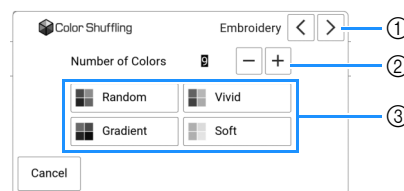

- ① Thread brand for colors
- ② Number of colors to be used.
- ③ Effects for schemes

* If you select [Vivid] or [Soft], proceed to step 5.

4 If you select [Random] or [Gradient], select [Auto], and then touch [OK].

Memo

- To specify the thread colors of the color scheme, select [Manual]. You can select up to six colors to be used with the [Random] effect. The selected thread colors will generate a random color scheme. You can select one color to be used with the [Gradient] effect. A gradient is generated with the selected thread color.

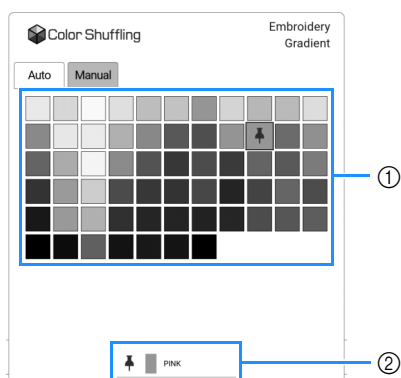

- Select a color from the palette.
- Selected color is displayed.

5 Touch the desired color scheme from samples.

- Touch [Refresh] to display the new schemes.

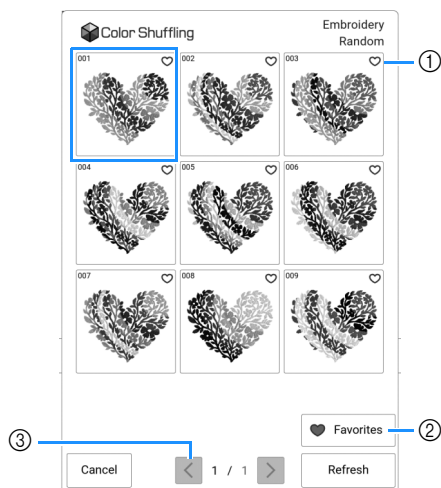

- Touch to temporarily register your favorite schemes. To release a favorite color scheme, touch again.
- Touch to display the color scheme favorites screen. Touch to remove the color scheme on color scheme favorites screen.
- Touch to review the previous schemes.

6 Touch [Set] to select the displayed color scheme.

Thread Color Sorting

This function allows you to embroider while replacing the thread spool a minimal number of times.

1 Touch [Layout] in the embroidery screen.

2 Touch .

- Touch the key again to return to the original setting.

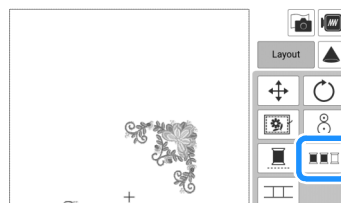

→ The embroidery color order is rearranged and sorted by thread colors.

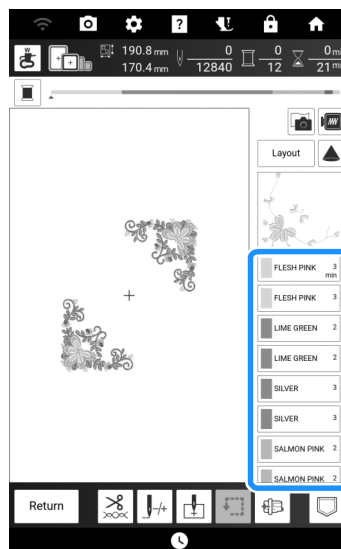

Memo

- This function does not work on overlapping designs.

Uninterrupted Embroidering (Using a Single Color)

A selected pattern can be stitched out in one color instead of multicolor. The machine will continue stitching without stopping for thread changes until the pattern is completed.

- 1 In the embroidery screen, touch [Layout].
- 2 Touch , and then touch [Layout].
 - * Touch the key again to return to the original setting.

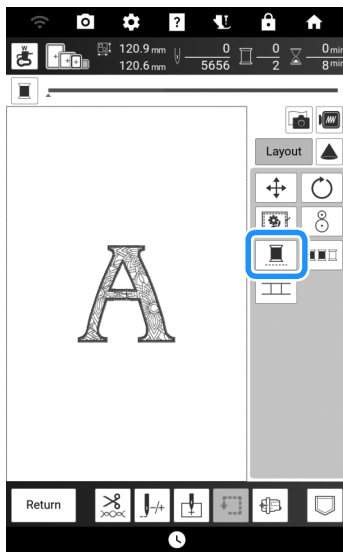

→ The thread color displayed on the screen will be grayed out.

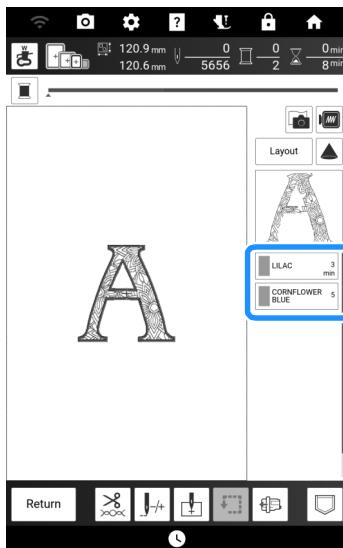

Various Embroidering Functions

No Sew Setting

No sew setting (which specifies that a thread color will not be embroidered) can be applied to a part of the pattern with a specific color.

- 1 Touch  in the embroidering edit screen.

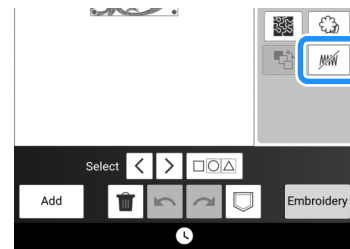

- 2 From the thread color sequence display, select the thread color that will not be embroidered.

→ The selected thread color is highlighted in blue.

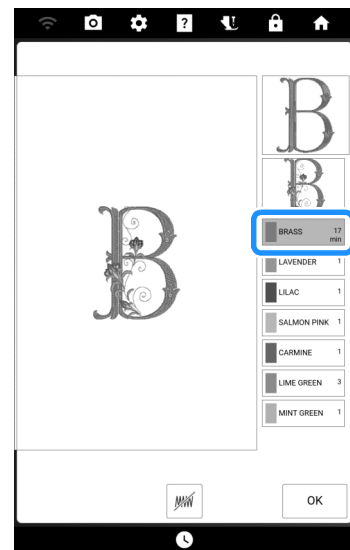

3 Touch .

→ The mark  appears to indicate that the selected thread color will not be embroidered. The parts of the pattern that will not be embroidered are hidden in the pattern preview screen.

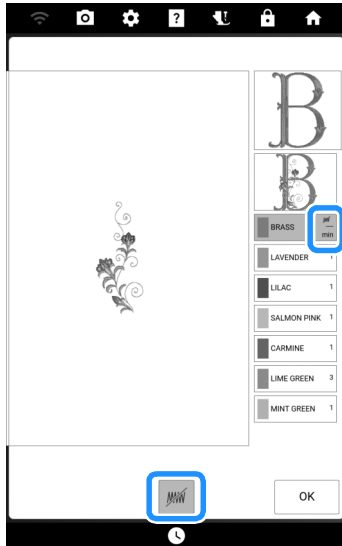



Memo

- To cancel the setting, select the thread color and touch .

4 If necessary, repeat steps **2** and **3** for all thread colors that will not be embroidered.

5 After specifying the desired settings, touch [OK].

6 Touch  and then touch  to check an enlarged image of the finished embroidery.

* After deselecting a region, check the image to be sure no previously hidden stitches are visible.

Memo

- When a pattern with the deselect region setting applied is saved, the deselect region setting is also saved. However, the pattern cannot be saved if the deselect region setting is applied to all thread colors.
- The parts with the deselect region setting applied are merely not displayed; they are not deleted. The embroidering area required to embroider the pattern is the same as for the original pattern.

Changing the Embroidering Order of Combined Patterns

The embroidering order of combined patterns can be changed.

1 Select a pattern, add additional pattern(s), adjust the layout of the patterns, and then display the [Edit] window.

2 If necessary, touch  to ungroup the pattern.

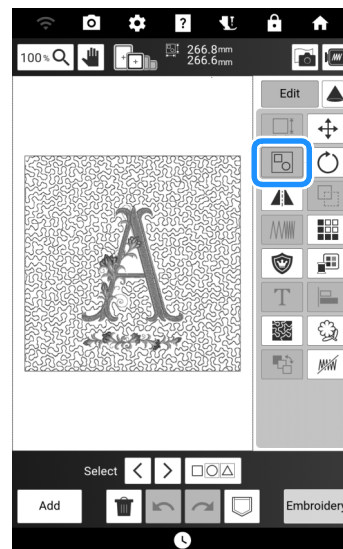

Memo

- The embroidering order for grouped patterns is changed group by group. To change the embroidering order of a pattern within a group, ungroup the pattern first.

3 Touch .

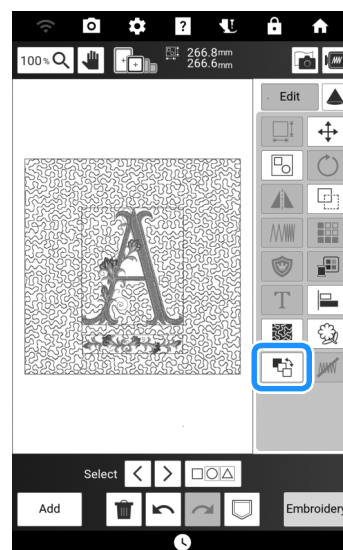

- 4** Select the pattern whose order is to be changed, and then touch a key to change its position in the embroidering order.

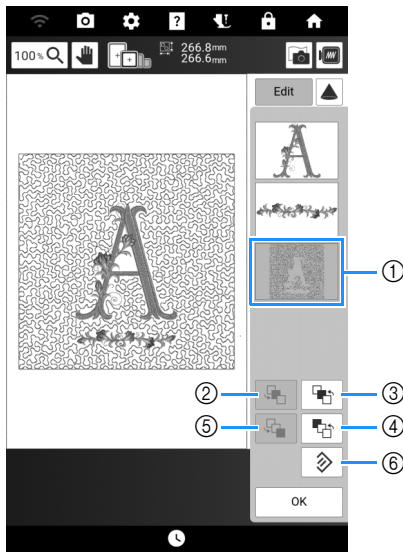

- ① Selected pattern
- ② Move the selected pattern back one position in the embroidery order.
- ③ Move the selected pattern ahead one position in the embroidery order.
- ④ Move the selected pattern to the beginning of the embroidery order.
- ⑤ Move the selected pattern to the end of the embroidery order.
- ⑥ Revert to the original embroidering order.

Memo

- The positions of overlapping patterns can be checked in the preview on the right side of the screen.

- 5** Touch [OK].

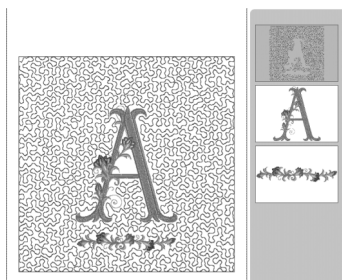

Basting Embroidery

Before embroidering, basting stitches can be sewn along the outline of the pattern. This is useful for embroidering fabric that cannot have stabilizer material affixed with an iron or adhesive.

Note

- It is recommended to finish combining and editing the pattern before selecting the basting setting. If the pattern is edited after selecting the basting setting, the basting and pattern may become misaligned.

- 1** Touch to display [Embroidery Basting Distance] of the settings screen.
- 2** Specify the distance from the pattern to the basting stitching.



- 3** Touch [OK].
- 4** Touch [Layout], and then touch to select the basting setting.

* Touch the key again to cancel the setting.

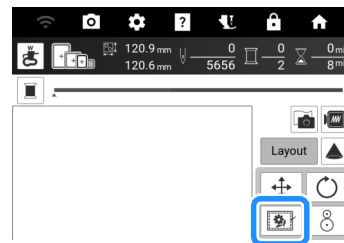

→ Basting is added to the beginning of the embroidering order.



Embroidering Linked Characters

Follow the procedure described below to embroider linked characters in a single row when the entire pattern extends beyond the embroidery frame.

Example: Linking “DEF” to the characters “ABC” using embroidery frame 10 cm × 10 cm (approx. 4 inches × 4 inches)

1 Select the character patterns for “ABC”.

2 On the embroidery screen, touch .

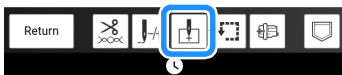

3 Touch  and then touch [OK].

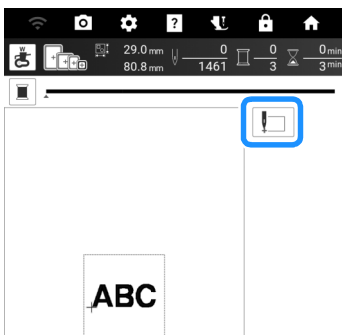

→ The needle is positioned in the lower-left corner of the pattern. The embroidery frame will move to the specified needle position.

4 Touch .



5 Touch  to turn off the thread cutting function and then touch [OK]. (page 141)

6 Press the “Start/Stop” button.

7 After the characters are embroidered, cut the threads to a generous length, remove the embroidery frame.

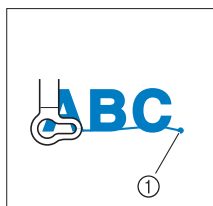

① End of the embroidering

8 Reposition the fabric in embroidery frame so that the right side of the letter “C” will be partially inside the embroidery frame; being careful so letters remain straight and level. Then reattach frame again so that the remaining characters (“DEF”) can be embroidered.

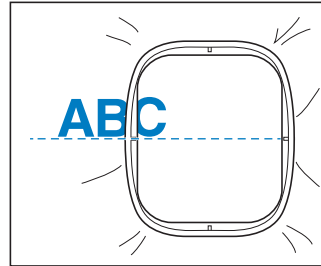

9 As in step 1, select the character patterns for “DEF”.

10 Touch  and then touch .

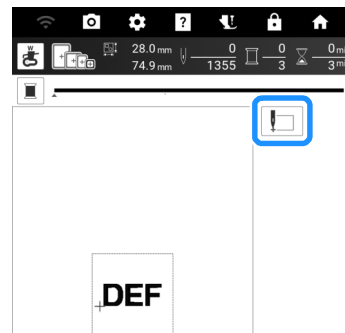

→ The carriage moves so that the needle is positioned in the lower-left corner of the pattern. You will need to match this point to the end of embroidering for the previous pattern.

11 Touch [OK].

12 Touch [Layout], then  to align the needle with the end of embroidering for the previous pattern.

* Touch  so that the pointer of the projector indicates the needle drop point onto the fabric. (page 139)

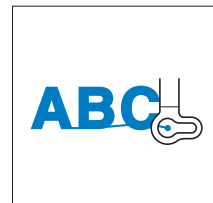

- 13** Press the “Start/Stop” button to begin embroidering the remaining character patterns.



Print and Stitch Function

Completed embroidery patterns combined with printed designs are built into this machine. Beautiful three-dimensional embroidered designs can be created by ironing a background onto fabric or printing it onto printable fabric, then doing complementary embroidery on top of the background.

Example: Using iron-on paper

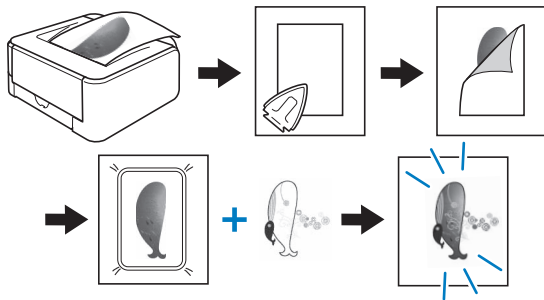

Exporting the Background Image and Positioning Image

Patterns with “P” in the lower-left corner of their key can be combined with printing.

Memo

- Refer to the “Embroidery Design Guide” for the detail of patterns which enable this function.

- 1** Select a pattern that can be combined with a printed design, and then touch

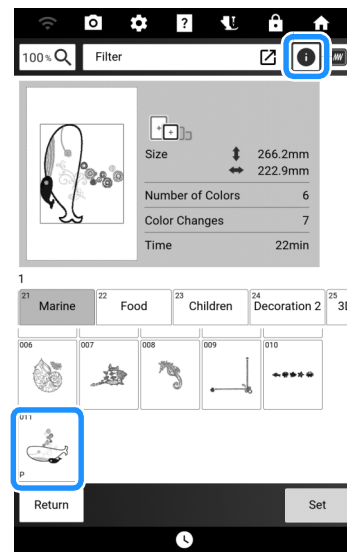

→ Only the embroidery pattern (not the background image of the selected embroidery pattern) is displayed.

- 2** Select the pattern, and then touch

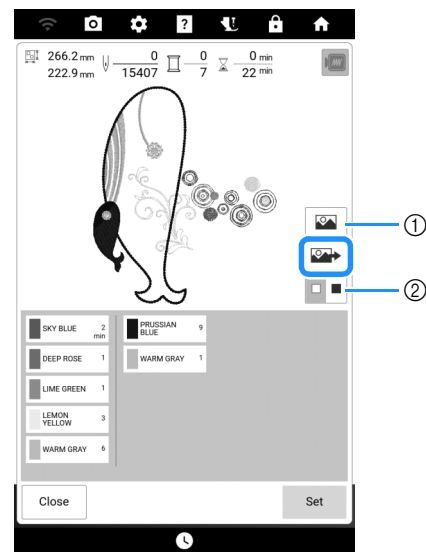

- ① An image of the pattern combined with the background appears.
- ② Touch to change the background color.

- 3** Touch the key for the corresponding media to save the files.

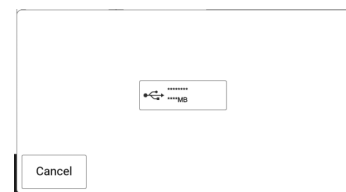

→ Two files of the background image only and one file for aligning embroidery into position are copied (PDF format) onto the USB media.

- **__r.pdf**
An image flipped on a vertical axis (for an iron-on transfer)



- **__n.pdf**
An image that is not flipped (for printing on printable fabric)



- **__p.pdf**
An image that is not flipped, but has positioning marks attached (for positioning)

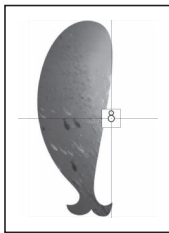

4 Touch 

■ Printing the Background and Embroidery Position Sheet

Print the PDF files of the background and embroidery position sheet. The background file that is printed differs depending on whether iron-on paper or printable fabric is used.

1 Open the PDF file to be printed.

- **Note**
Print the background and embroidery position sheet in their original dimensions. If an image is printed in a different size, the sizes of the embroidery pattern and background may not match. In addition, the built-in camera cannot detect the embroidery position mark. Make sure that the print settings are correctly specified.

2 Print the background image.

- * When printing onto iron-on paper, print the file named “__r.pdf” (an image flipped on a vertical axis). When printing onto printable fabric, print the file named “__n.pdf” (an image that is not flipped).

Note

- Before printing onto iron-on paper or printable fabric, we recommend performing a test print to check the print settings.
- For details on how to use iron-on transfer sheets or printable fabric, refer to the instructions for the iron-on transfer sheets and printable fabric.
- Some printers will automatically print an image flipped if an iron-on transfer sheet is selected as the paper. For details, refer to the instructions for the printer being used.

3 Print the embroidery position sheet (file named “__p.pdf”) onto plain paper.

Note

- When printing the PDF file for the embroidery position sheet, specify the highest image quality possible for full-color printing. In addition, we recommend printing on matte paper. If this is not done, the built-in camera may not be able to correctly detect the embroidery positioning mark.

4 If an iron-on transfer sheet is used, transfer the image onto fabric.

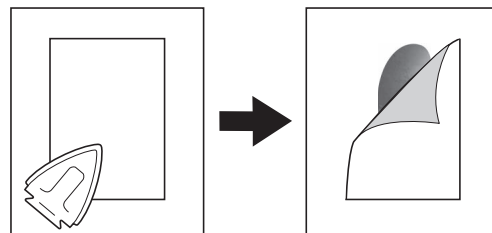

■ Embroidering Patterns

1 Hoop in the embroidery frame the fabric with the background image.

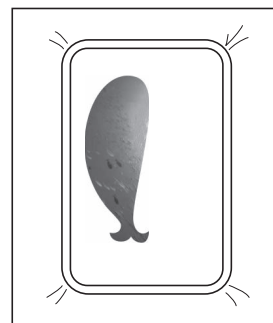

2 Cut the embroidery position sheet so it can easily be positioned aligned with the background image on the fabric.

* Lines or color changes in the image can help you find the correct alignment position.

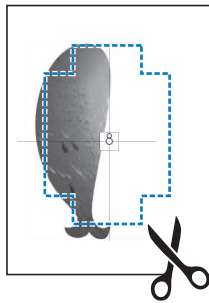

3 Place the paper printed with the positioning image on top of the fabric so that the pattern is aligned, and then affix the paper to the fabric with cellophane tape to prevent the paper from moving.

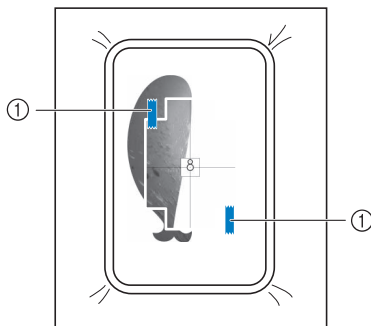

① Cellophane tape

4 After checking that a pattern is selected, touch [Embroidery].

Note

• Before embroidering, check that the embroidery position sheet is perfectly aligned with the background.

5 Align the embroidering position according to steps 1 through 7 of “Using the Embroidery Positioning Sticker” on page 159.

* With this function, the fabric will be aligned with the mark on the embroidery position sheet (instead of the embroidery positioning sticker) affixed to the fabric. When performing step 3 of “Using the Embroidery Positioning Sticker”, use the center of the pattern as the reference point. In step 4, skip affixing the embroidery positioning sticker.

6 Remove the positioning sheet and press the “Start/Stop” button to begin embroidering.

Picture Play Embroidery Function

A photo can be converted into embroidery data.

Note

• The auto background removal and style conversion functions utilize Artificial Intelligence (AI) technology. While we strive for accuracy and quality, please note that the output generated may vary.

Adjusting the Imported Image

Memo

- Photos that show an enlargement of the object to be embroidered or are bright and sharp are most appropriate for conversion.
- The following types of photos are not appropriate for creating embroidery patterns.
 - Photos where the subject is small, such as in photos of gatherings
 - Photos where the subject appears dark, such as photos taken in a room or taken with backlighting

1 Save the picture to be converted into embroidery data onto a USB flash drive or transfer to the machine using “My Design Snap App”. (page 225)

2 Touch [Picture Play Embroidery].

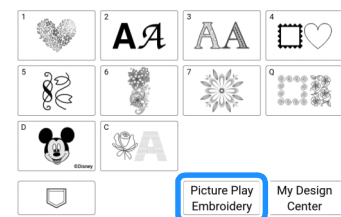

3 Touch the desired source.

- * For details on available image data files, refer to “Specifications” on page 271.
- * If two USB media are connected to the machine, check the USB media names that are displayed, and then touch the name of the USB media that you wish to use.

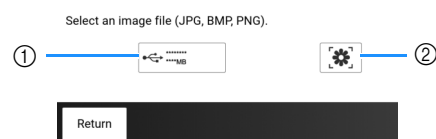

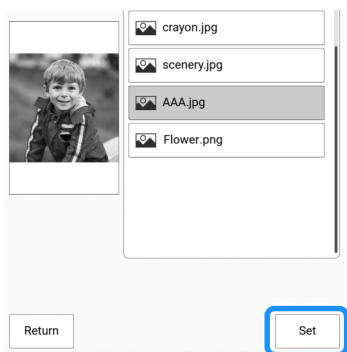

- ① Retrieve from a USB media.
- ② Retrieve image data sent from My Design Snap App. (page 225)

4 Select the image to be retrieved, and then touch [Set].

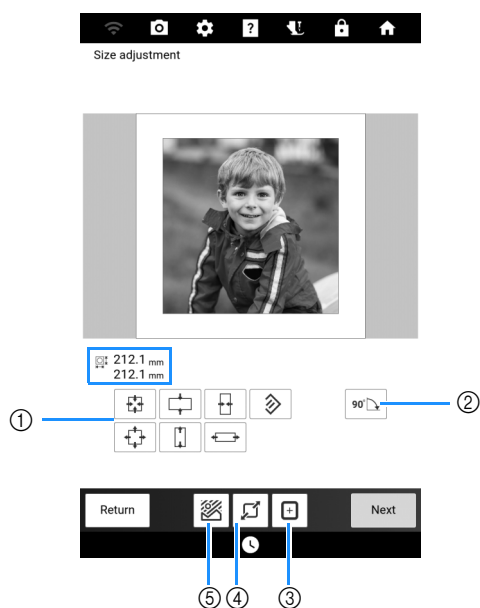

5 Check the embroidery pattern size and adjust it.



- ① Change the size of the image data file. In order to return to its original size, touch .
- ② Rotate the image data file 90 degrees.
- ③ Change the size to fit the embroidery frame size. (Refer to step 7)
- ④ Frame an area of the image. (Refer to “Framing the Image” on page 179)
- ⑤ Remove the background. (Refer to step 6)

Memo

- The recommended sizes of embroidery patterns are listed below.
 - Face only: 100 × 100 mm (approx. 4 inches × 4 inches) or larger
 - Head and face: 130 × 180 mm (approx. 5 inches × 7 inches) or larger
 - The subject for detailed embroidery: 75 × 75 mm (approx. 3 inches × 3 inches) or larger
- The image framing functions (④) and the background removal (⑤) cannot be used at the same time.

6 If necessary, remove the background. Touch , select [Auto (AI)], and then switch on [Background removal]. Touch [Preview] to confirm the cropping area, and then touch [OK].

* If [Auto (AI)] is selected and [Background removal] is set to on, the machine will automatically remove the background. If the desired results are not achieved, refer to “Removing the Background in [Custom] Mode” on page 179.

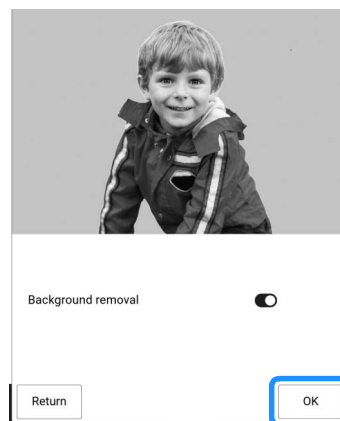
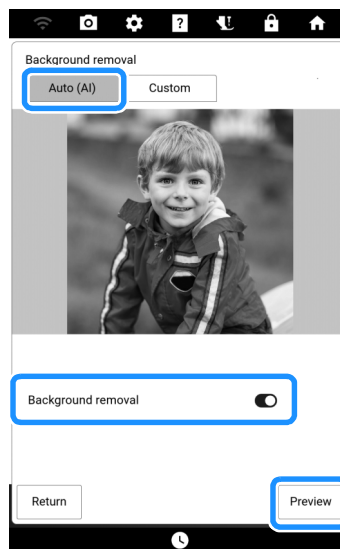

7 If necessary, touch  to change the size of the pattern to fit the selected embroidery frame size.

* The embroidery frames that can be used with this function are listed.

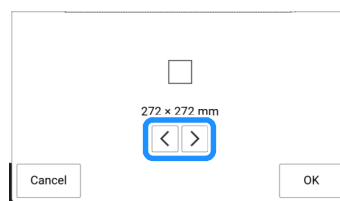

- 8** After editing of the image is finished, touch [Next].

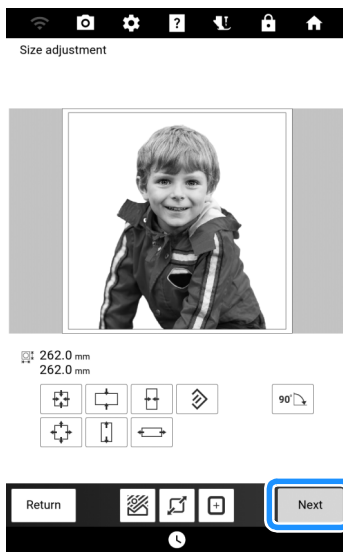

→ Proceed to “Selecting the Conversion Method” on page 181.

■ Framing the Image

- 1 Follow steps 2 through 5 of “Adjusting the Imported Image” on page 177.
- 2 Touch . Select the image area to be framed, and then touch [OK].

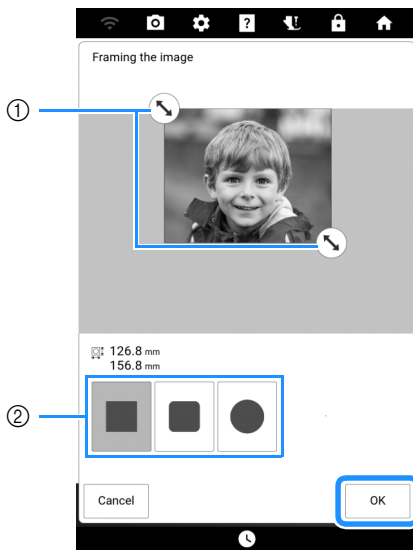

- ① Drag to select the image area to be framed.
- ② Select a shape to frame the image with.

- 3 Follow steps 7 through 8 of “Adjusting the Imported Image” on page 177.

■ Removing the Background in [Custom] Mode

For this example, the background will be removed from a photo of a flower.

- 1 Touch [Custom] in step 6 of “Adjusting the Imported Image” on page 177. For this example, first touch [Preview] to display the cropping area.

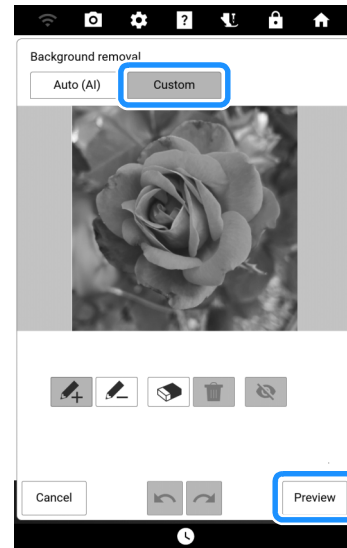

→ The cropping area is highlighted in cyan.



Memo

- The results from using [Custom] mode to detect the cropping area without first specifying it may differ from the results from using [Auto (AI)] mode to remove the background.

2 With the pens, mark the areas to be, and not to be, extracted. And then touch [Preview] to confirm the cropping area.

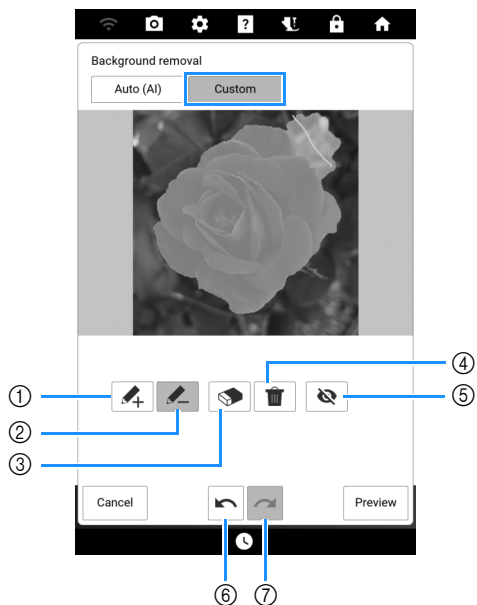

- ① With the pink pen, mark the areas to be extracted (will be added to the cropping area).
- ② With the yellowish green pen, mark the areas not to be extracted (will be removed from the cropping area).
- ③ Trace over lines drawn with ① or ② above in order to erase the drawn line.
- ④ Erases all drawn lines.
- ⑤ Hide all lines drawn with pen ① or ②.
- ⑥ To undo the previous operation.
- ⑦ To redo the last operation that was undone.

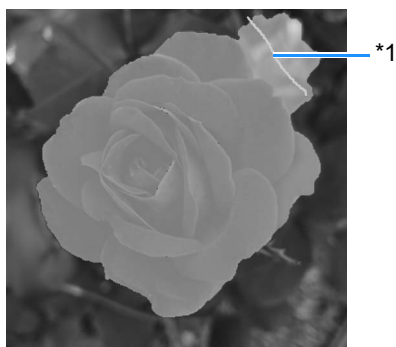

*1 Select , and then use the yellowish green pen to mark areas not to be extracted.

Memo

- When selecting areas to be added to or removed from the cropping area, the entire area does not need to be completely filled with pen marks.

3 Continue drawing lines and touching [Preview] until the desired cropping area is achieved.



① Select , and then use the pink pen to mark areas to be extracted.

4 Touch [OK].

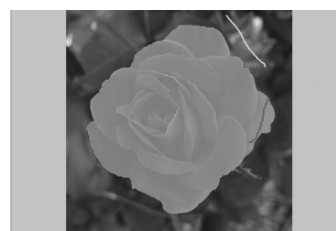

* Touch  to hide all lines drawn with pens.

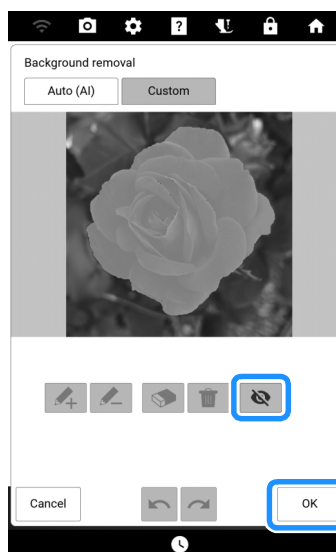



5 Touch [Next].

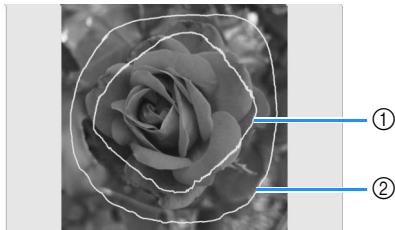

Memo

- To specify the cropping area before it is detected, perform step 1 without touching [Preview]. Roughly mark the areas to be and not to be extracted in step 2, and then touch [Preview]. And then continue with step 3.



- 1 Select , and then use the pink pen to mark areas to be extracted.
- 2 Select , and then use the yellowish green pen to mark areas not to be extracted.

Selecting the Conversion Method

Using the Original Image (No Style Conversion)

The displayed image can be converted directly to embroidery data, without using style conversion. The image can be adjusted as necessary before it is converted to embroidery data.

- 1 Make sure that [Original] is displayed in the box.

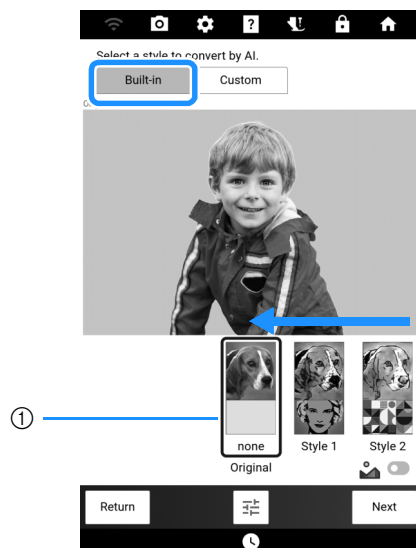

1 Box

- 2 Touch  to adjust the image brightness, etc. Touch [OK] to apply the settings.

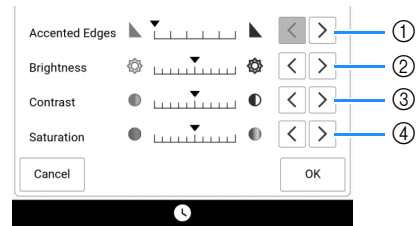

- 1 Adjust the amount of emphasis applied to the outline of the image. Touching  repeatedly makes the boundaries between bright and dark areas clearer.
- 2 Adjust the image brightness.
- 3 Adjust the image contrast.
- 4 Adjust the image saturation.

- 3 Touch [Next].

→ Proceed to "Selecting Appropriate Thread Colors and Density" on page 183.

Using the [Built-in] Style

By applying any of the various built-in styles to an image, you can create a variety of new images that have a different impression from the original, then convert them to embroidery data. For this example, a photo of a flower will be converted.

- 1 Swipe until your image with the desired [Style] appears in the box. Switch  on or off. And then touch [Preview].

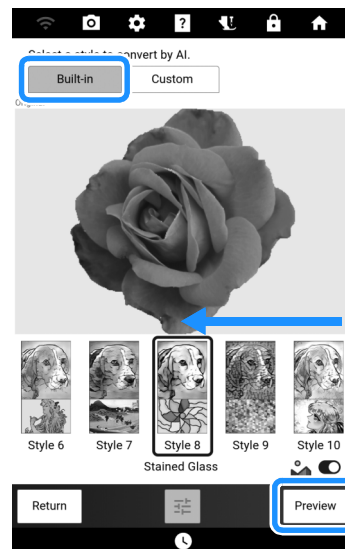

Memo

- If  is switched off, style conversion is applied using the colors from the original photo.

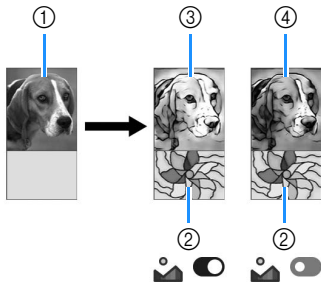

- ① Sample image (without style conversion)
- ② Style image
- ③ Sample image (with style conversion using the colors from the style image)
- ④ Sample image (with style conversion using the colors from the original photo)

2 Check the image, and then touch [Next].

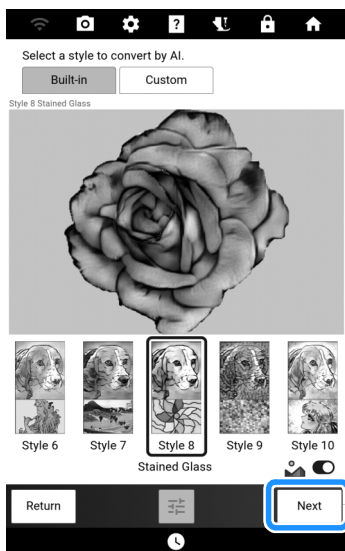

→ Proceed to “Selecting Appropriate Thread Colors and Density” on page 183.

Using the [Custom] Style

By selecting any desired image as the style image, you can create a unique style conversion image. For this example, a photo of a mountain will be converted.

- 1 Save to USB media the image to be used as the style as well as the photo to be converted into the embroidery data.**
- 2 Adjust the imported Image. (page 177)**

3 Touch [Custom]. Touch , and then select the saved image. Switch on or off. And then touch [Preview].

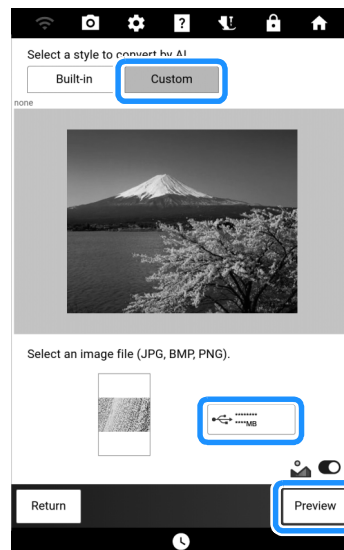

4 Check the image, and then touch [Next].

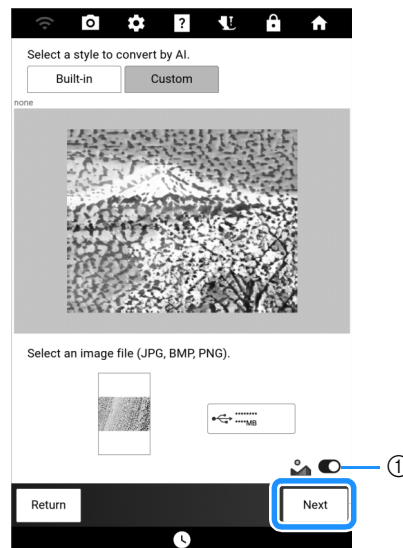

- ① When switched off, style conversion is applied using the colors from the original photo. For details, refer to “Using the [Built-in] Style” on page 181.



→ Proceed to “Selecting Appropriate Thread Colors and Density” on page 183.

Selecting Appropriate Thread Colors and Density

- 1 Check the conversion results, and then, if it is acceptable, touch [Set] to continue with step 3. If necessary, specify the maximum number of thread colors, the thread colors that must be used, and the thread density.

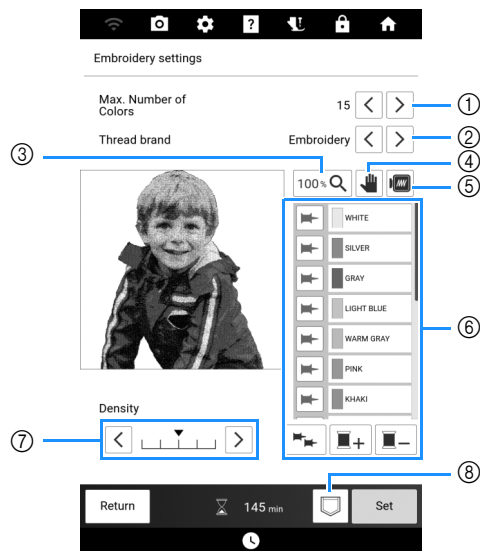

- 1 Specify the maximum number of thread colors.
- 2 Specify the thread brand.
- 3 Change the magnification ratio for displaying the image.
- 4 This indicates that a magnified image can be repositioned (no action is required).
- 5 Preview the converted embroidery data.
- 6 Specify the thread color list. The thread colors being used can be changed.

When (pin thread color key) is blue, the thread color on the key beside it is kept for converting the image to embroidery data. Touch (gray) to keep the thread color beside the key. Touch (blue) to no longer keep the thread color beside the key.

Touch to keep the thread colors of all thread spools. Touch the key again to no longer keep all thread colors.

Touch , select a thread color, and then touch [OK] to add the selected thread color to the list. Select a thread color in the thread color list, and then touch to remove the selected thread color.

- 7 Adjust the thread density.
- 8 Save the embroidery pattern.

- 2 For this example, we will convert the image with a maximum number of 12 colors and keep two thread colors. Touch [Preview] to apply the settings to the pattern.

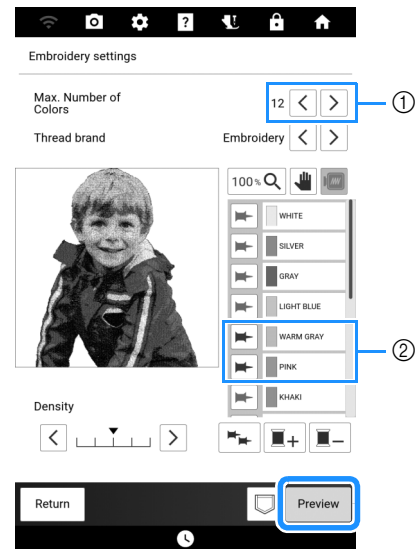

- 1 Maximum number of thread colors.
- 2 Kept thread colors (blue pins)

- 3 Check the conversion results, and then touch [Set].

→ The following message appears. Touch [OK] to display the converted pattern in the embroidery edit screen.

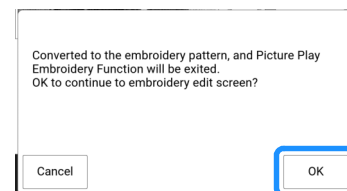

Note

- Since converted embroidery pattern has a high thread density, it may shrink when it is embroidered. Hoop the fabric firmly secured in the embroidery frame before embroidering. For Picture Play embroidery function, we recommend using the separately sold magnetic frame, which offers more strength for holding fabric taut.

Appliqué and Couching

Creating an Appliqué Piece

Appliqué pieces can be created from the built-in patterns and imported patterns. This is convenient for fabrics that cannot be embroidered or when you wish to attach an appliqué to a garment.

■ Creating an Appliqué Piece



Note

- Felt or denim fabrics are recommended to make the appliqué piece. Depending on the pattern and fabric used, lighter weight fabrics may cause the stitching to appear smaller.
- For best results, be sure to use stabilizer material for embroidering.

1 Select the pattern, and edit it if necessary.

Note

- Finish combining and editing the pattern before selecting the appliqué setting. If the pattern is edited after selecting the appliqué setting, the appliqué stitching and pattern may become misaligned.
- Since an outline is added, the pattern for an appliqué piece (when the appliqué setting is selected) will be larger than the original pattern. First, adjust the size and position of the pattern as shown below.

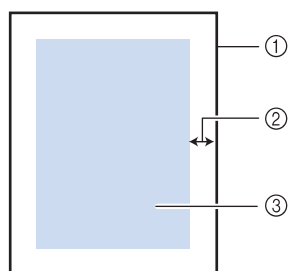

- ① Embroidering area
- ② About 1 cm (approx. 3/8 inch)
- ③ Pattern size

2 Touch [Edit], and then touch .

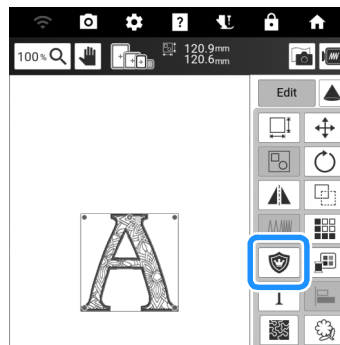

3 Specify the distance between the pattern and the appliqué outline, and then touch [OK].

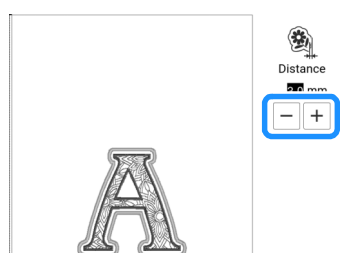

→ The pattern and appliqué outline are grouped.

4 Touch [Embroidery].

→ The steps for creating the appliqué piece are added to the embroidering order.

Memo

- Three steps are added to the embroidering order: appliqué cutting line, position of pattern placement on the garment, and appliqué stitching.

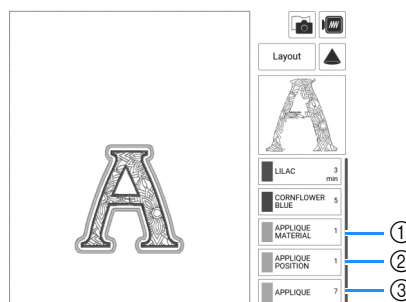

- ① Cutting line for appliqué
- ② Position of pattern placement on garment
- ③ Appliqué stitching

- When setting the [Thread color] to [#123] (thread number) in the settings screen, the following screen is displayed.

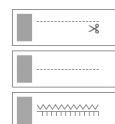

Note

- An appliqué piece cannot be created if the pattern is too large or too complicated or a combined pattern is separated. Even if the selected pattern fits within the embroidering area, the entire appliqué pattern may exceed the embroidering area when the outline is added. If an error message appears, select a different pattern or edit it.

5 Fuse or stick a piece of stabilizer to the back of the felt or denim fabric to be used as the appliqué piece.

6 Hoop the appliqué fabric in the embroidery frame, attach the embroidery frame to the machine, and then start embroidering.

7 After the pattern is embroidered, thread the machine with the thread for the cutting line, and then sew the cutting line (APPLIQUE MATERIAL).

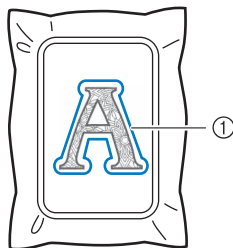

① Cutting line for appliqué

Memo

- We recommend using thread for the cutting line that is closest to the color of the fabric.

8 Remove the appliqué material from the embroidery frame, and then carefully cut along the stitching. After cutting, carefully remove all of the cutting line thread.

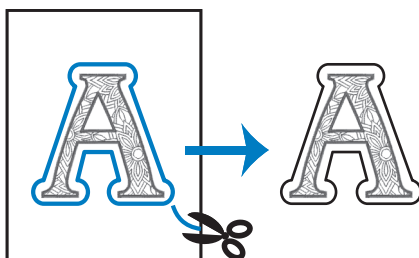

Note

- Depending on the pattern density and fabric used, there may be shrinking of the pattern or the appliqué may be misaligned with the placement line. We recommend cutting slightly outside of the cutting line.
- When using patterns that are vertically and horizontally symmetrical, use a chalk pencil to indicate the pattern orientation before cutting it out.
- Carefully cut out the pattern on the outline you just sewed. Do not cut inside the cutting line, otherwise the appliqué fabric will not be caught by the appliqué stitch.

9 Hoop two layers of non-woven water soluble stabilizer in the embroidery frame.

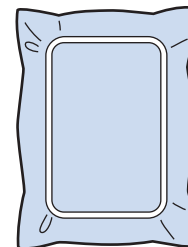

Note

- Put together two layers of water soluble stabilizer, otherwise the stabilizer material may tear during embroidering.

10 Thread the machine with the thread for the outline from step 12, and then sew the placement line for the appliqué position (APPLIQUE POSITION).

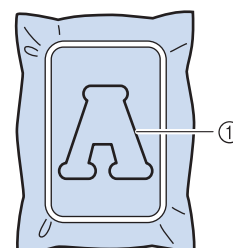

① Pattern placement line

- 11** Lightly apply glue and paste the appliqué piece so that it aligns with the placement line.

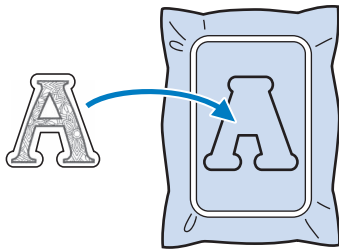

Note

- Before pasting the appliqué piece down, make sure the appliqué piece is positioned correctly within the placement line.

- 12** With the machine threaded using the thread for the outline from step 10, embroider the outline (APPLIQUE).

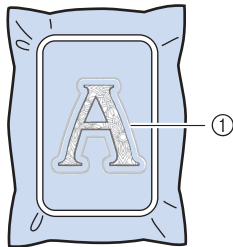

① Outline of appliqué piece

Memo

- The outline is sewn using satin stitching.
- Some glue may get onto the embroidery foot, needle, and needle plate at this time. Finish embroidering the appliqué pattern, and then clean off the glue.

- 13** After embroidering is finished, remove the stabilizer material from the embroidery frame.

- 14** Use scissors to cut the excess water soluble stabilizer from outside the appliqué outline.

- 15** Soak the appliqué piece in water to dissolve the water soluble stabilizer.

* For details, refer to the instruction manual for the water soluble stabilizer.

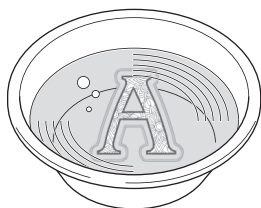

- 16** Dry the appliqué piece, and then iron it if necessary.

Note

- Do not apply a strong force when ironing, otherwise the stitching may be damaged.

Using a Frame Pattern for the Outline

Using a frame pattern, the desired shape can be added as the outline of the appliqué. To select the desired frame, refer to “Selecting Frame Patterns” on page 136.



- 1** Select the pattern and edit, if necessary. And then touch [Add].
- 2** Select the desired frame shape and pattern, and add it to the appliqué pattern.
- 3** Touch [Edit] to edit the frame pattern to fit the size of the appliqué pattern.
- 4** Touch .

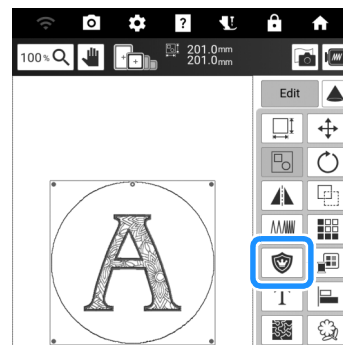

- 5** Specify the distance between the frame pattern and the appliqué outline, and then touch [OK].
- 6** Touch  to ungroup the patterns.

- 7 Use **<** **>** to select the frame pattern, and then touch **🗑️** and **[OK]**.

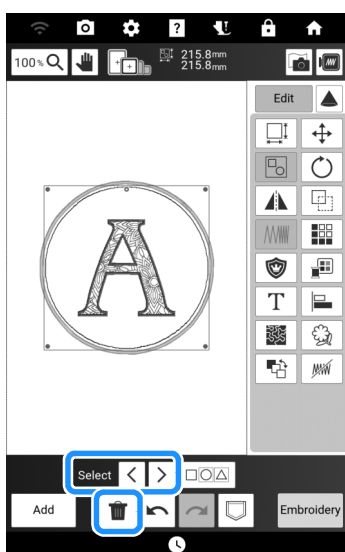

→ The frame pattern is deleted.

- 8 Touch **[Embroidery]**.

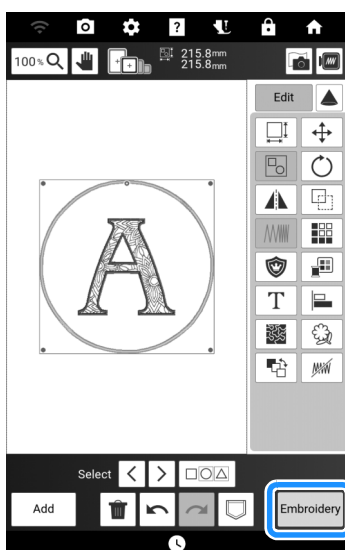

- 9 Continue with step 5 of “Creating an Appliqué Piece” on page 184 to complete the appliqué piece.

Embroidering the Appliqué Patterns

Note

- Refer to “Embroidery Design Guide” to review the recommended method for built-in appliqué patterns. Some appliqué patterns differ from the procedure described in this manual.

This machine can embroider patterns that contain an appliqué. If selecting an embroidery pattern that contains an appliqué, the steps for appliqué appear in embroidery color order display. The display will change depending on the [Thread color] setting. (page 25)

①

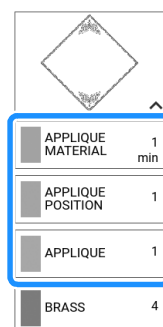

②



- When [Name of Color] is selected.
- When [#123] (thread number) is selected.

Required materials

- Fabric for the appliqué piece
- Fabric for the appliqué base
- Stabilizer material
- Craft glue
- Embroidery thread

Memo

- The specific names and numbers of the thread colors to be used when creating and attaching the appliqué piece will not appear in the embroidery color order display. Use thread colors that coordinate with the appliqué pattern and fabrics.

1. Creating the Appliqué Piece

- 1 Attach stabilizer material to the wrong side of the appliqué fabric.
- 2 Sew the cutting line of the appliqué piece. Remove the fabric for the appliqué piece from the embroidery frame, and then carefully cut along the sewn cutting line.

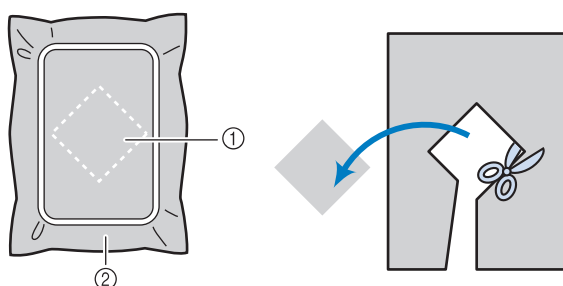
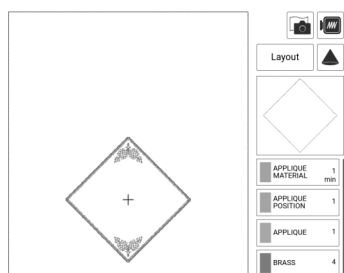

- ① Cutting line for appliqué piece
- ② Fabric for appliqué piece

Note

- If the appliqué piece is cut out along the inside of the cutting line, it may not be correctly attached to the fabric. Therefore, carefully cut out the appliqué piece along the cutting line.
- After cutting out the appliqué piece, carefully remove the thread.

2. Sewing the Appliqué Position on the Base Fabric

- 1 Attach stabilizer material to the wrong side of the fabric for the appliqué base.

2 Sew the appliqué position.

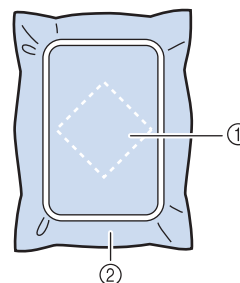
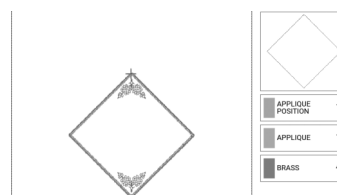

- ① Appliqué position
- ② Base fabric

3 Remove the embroidery frame from the embroidery unit.

Note

- Do not remove the base fabric from the embroidery frame until all embroidering is finished.

3. Affixing the Appliqué Piece to the Base Fabric

- 1 Lightly apply craft glue to the back of the appliqué piece, and then attach it to the base fabric within the outline of the position sewn in step 2 of “2. Sewing the Appliqué Position on the Base Fabric” on page 188.

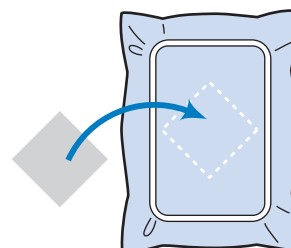

Note

- If the appliqué piece cannot be attached to the base fabric with craft glue, securely baste it in place with basting stitches.
- If thin fabric is used for the appliqué piece, reinforce and secure it in place with an iron-on adhesive sheet. An iron can be used to attach the appliqué piece to the appliqué location.

- 2 After the appliqué piece is attached, attach the embroidery frame to the machine.
- 3 Thread the machine with the embroidery thread, lower the presser foot, and then press the “Start/Stop” button to embroider the appliqué.

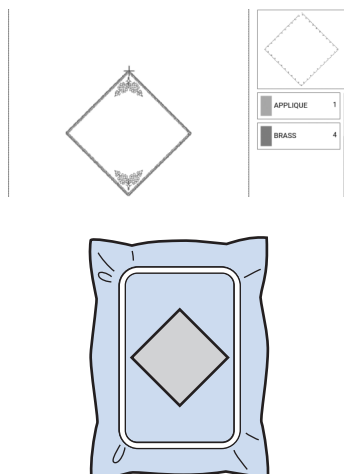

■ 4. Embroidering the Remainder of the Pattern

- 1 Change the embroidery thread according to the embroidery color order display, and then finish embroidering the remainder of the pattern.

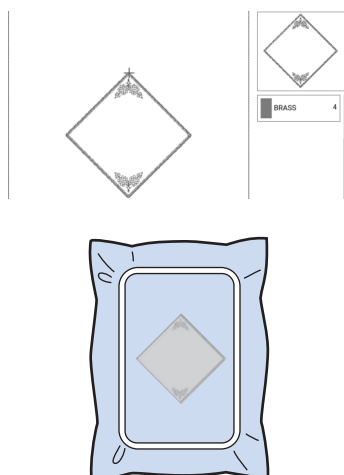

📖 Memo

- Since glue may become attached to the embroidery foot, needle or needle plate, clean off any glue off after finishing embroidering the appliqué pattern.
- For best results, trim all excess threads each time the thread color is changed.

Using a Frame Pattern to Make an Appliqué

💡 Note

- If you change the size or position of the patterns when making an appliqué, make a note of the size and the location.

■ Method 1

You can use framed patterns of the same size and shape to create an appliqué. Embroider one pattern with a straight stitch and one pattern with a satin stitch.

- 1 Select a straight stitch frame pattern. Embroider the pattern onto the appliqué material, then cut neatly around the outside of the shape.

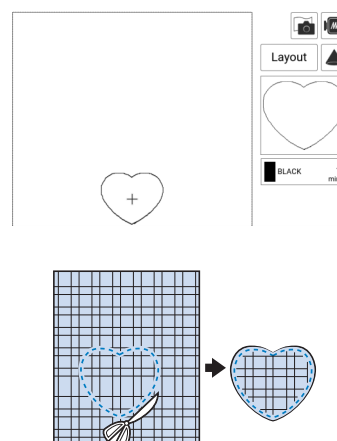

- 2 Embroider the same pattern from step 1 onto the base fabric.
- 3 Apply a thin layer of fabric glue or a temporary spray adhesive to the rear of the appliqué created in step 1. Attach the appliqué to the base fabric matching the shapes.

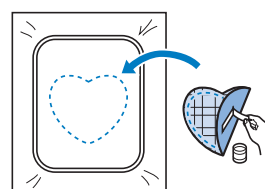

- 4 Select the satin stitch frame pattern of the same shape as the appliqué. Embroider over the appliqué and base fabric from step 3 to create the appliqué.

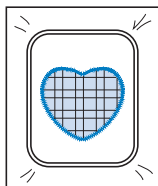

Method 2

- 1 Select a straight stitch frame pattern, and embroider the pattern onto the base fabric.

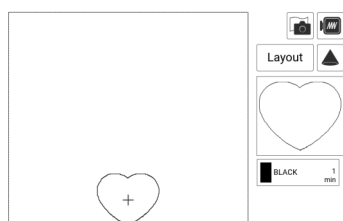

- 2 Place the appliqué fabric over the pattern embroidered in step 1 and embroider the same pattern on the fabric for the appliqué piece.

* Be sure that the appliqué fabric completely covers the stitching.

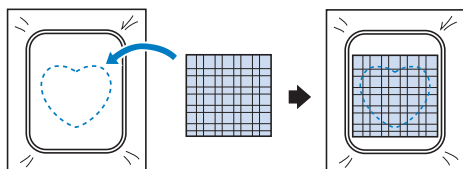

- 3 Remove the embroidery frame from the embroidery unit, and cut around the outside of the stitches of the fabric for the appliqué piece. And then, reattach the embroidery frame to the embroidery unit.

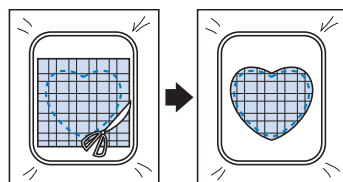

Note

- Do not remove the fabric from the embroidery frame to cut it. Also, do not pull strongly on the fabric. Otherwise, the fabric may loosen in the embroidery frame.

- 4 Select the satin stitch frame pattern of the same shape as the appliqué and embroider the satin stitch pattern to create an appliqué.

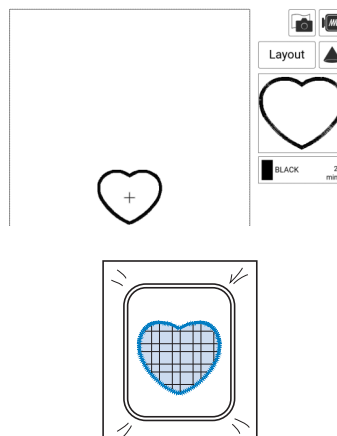

Embroidering Couching Patterns

Couching patterns can be embroidered using yarn.

⚠ CAUTION

- When using yarn, we recommend selecting yarn of weight 4 (MEDIUM ). Medium yarn is often referred to as worsted weight, 20 knitted stitches per 10 cm, or 9-11 wraps per inch. The diameter of the yarn is approximately 2-3 mm (approx. 1/12-1/8 inch). If the yarn is extremely thin or thick, has an unusual shape (flat or furry), or more than 2 yarns, the best finishing results may not be achieved, or injuries or damage may result.

Note

- Before embroidering your project, do trial embroidery on a scrap piece of fabric that is the same as that used in your project.

■ Preparing for Embroidery Couching

- 1 Turn off the machine. Attach the embroidery unit.
- 2 Install a bobbin wound with embroidery bobbin thread.
- 3 Turn on the machine.
- 4 Touch [Embroidery] in the home page screen, and then touch .

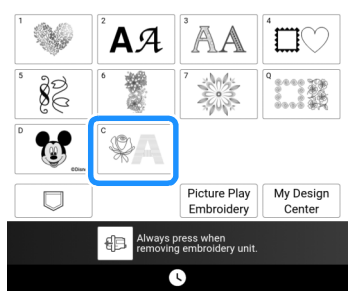

- 5 Select the desired pattern from the desired category. And then touch [Set].

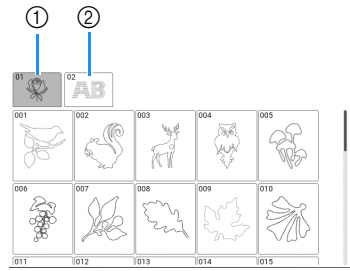

- ① Couching patterns
- ② Fill couching embroidery font

- 6 Touch  to lock all keys and buttons, and then raise the presser foot lever.

- 7 Attach embroidery couching foot “Y”.

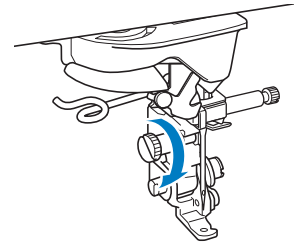

⚠ CAUTION

- When using embroidery couching foot “Y”, make sure the machine is in embroidery mode. Otherwise, the needle will strike the embroidery couching foot, causing the needle to break and possibly causing injury.

- 8 Rotate the handwheel and check that the needle is in the left half of the hole in embroidery couching foot “Y”.

If the needle is not in the left half, use the multi-purpose screwdriver to turn the screw of embroidery couching foot “Y” to adjust the position of the embroidery foot. Turn the screw toward you to move the embroidery foot to the right. Turn the screw toward the back to move the embroidery foot to the left. After making adjustments, rotate the handwheel and check that the needle does not touch the presser foot.

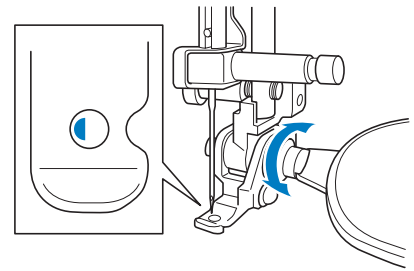

9 Attach the spool stand to the machine.

At this time, do not raise the telescopic thread guide shaft.

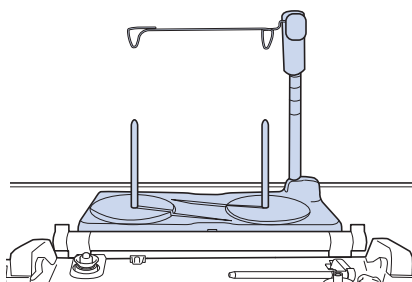

* Refer to "Using the Spool Stand" on page 45.

10 Insert the yarn guide into the slot on the top left of the machine.

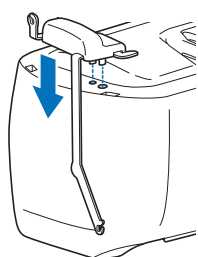

11 Pass the yarn through the telescopic thread guide and the yarn guide (①) to (②).

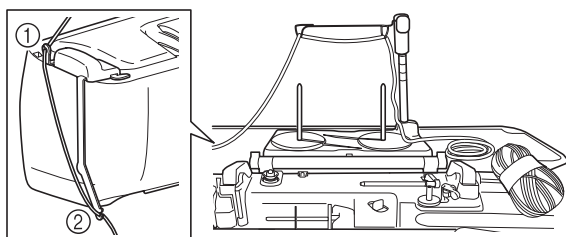

Note

- Pull off an appropriate amount of yarn from the ball so that the yarn does not become taut.
- Make sure that the yarn does not become entangled as you work.

12 Pass the yarn through the guide on embroidery couching foot "Y".

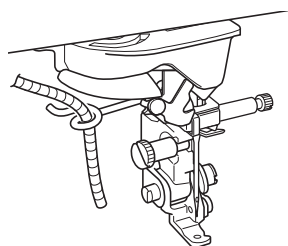

13 Thread the yarn through embroidery couching foot "Y".

Pass the yarn through the loop in the yarn threader, and then pass the threader from top to bottom through the hole in embroidery couching foot "Y". Pull the yarn to the front of the machine.

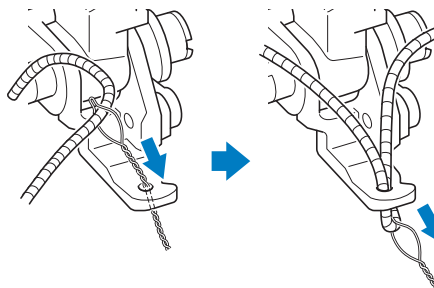

Memo

- Place a sheet of paper under the presser foot to smoothly pass the yarn threader through the hole in embroidery couching foot "Y".

14 Touch [] to unlock all keys and buttons.

15 Thread the machine with the upper thread by using the spool pin. (page 42)

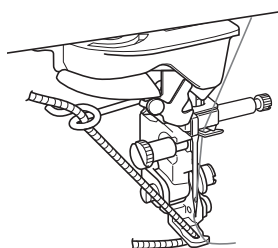

Note

- Do not use the spool stand for upper thread. Otherwise thread may tangle with yarn.

Memo

- For best results, use an upper thread that is the same color as the yarn.

16 Press [] (Presser foot lifter button) twice to raise the presser foot and then attach the embroidery frame to the embroidery unit.

■ Embroidering a Couching Pattern

- 1 Touch [Embroidery].
- 2 Make sure that about 20 cm (approx. 8 inches) of yarn is pulled to the front of the machine.
- 3 While holding the yarn in your hand in front of you, press the “Start/Stop” button.

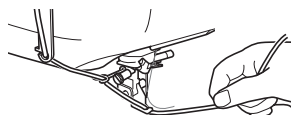

⚠ CAUTION

- Pulling the yarn upwards may cause it to catch on the needle, causing it to break. Be careful not to allow the yarn to catch on the needle.

💡 Note

- Before embroidering, make sure that there is enough yarn, upper thread and bobbin thread.
- Make sure that the yarn passes smoothly through the guides. Unravel as much yarn from the ball as necessary so that the yarn does not become taut.
- Use yarn that has no knots.

4 After embroidering several stitches, release the yarn.

→ When embroidering is finished, the machine will automatically trim the threads and stop.

📝 Memo

- When using a high-density yarn, the upper thread tension may be disturbed. If this happens, it is possible to improve it by raising the [Embroidery Foot Height] by about 1 mm on the settings screen.

5 Cut the yarn, leaving about 20 cm (approx. 8 inches).

- 6 Punch a hole through the fabric with an awl or tapestry needle and then use the yarn threader to pull the excess yarn to the wrong side of the fabric.

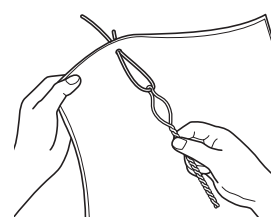
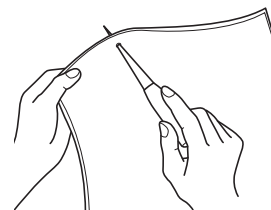

- 7 Tie the end of the yarn so it cannot be pulled out, and then use scissors to cut off any excess yarn.

Embroidering Quilting

Creating Quilting Patterns around a Design

Stippling, echo quilting, and decorative fill patterns can be created around the machine's built-in patterns or original embroidery data without using My Design Center.

Memo

- If this function is used with batting sandwiched between two layers of fabric, the embroidery pattern and stippling may become misaligned. Stippling can be added in My Design Center after the pattern is embroidered. For details, refer to "Decorative Stitching Around a Pattern" on page 249.

1 Select the pattern that stippling will be added around.

* To select multiple patterns, refer to "Selecting Multiple Patterns at the Same Time" on page 148.

2 Touch in the embroidery edit screen.

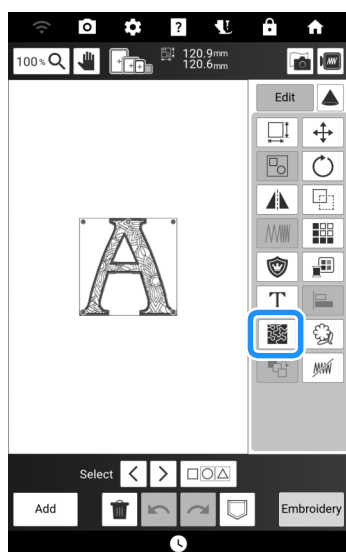

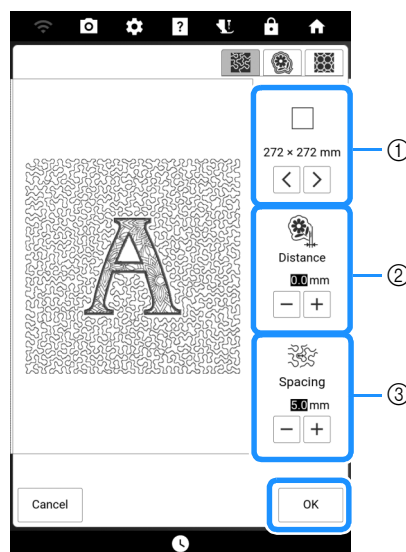

→ Stippling is automatically applied around the selected pattern.

3 After specifying the stitch settings for the stippling, touch [OK].



- ① The stippling is added within the area of the selected embroidery frame size. If the pattern is larger than the selected embroidery frame size, the area indicating the embroidery frame size will appear in gray, and stippling will not be added.
- ② Specify the distance from the outline of the pattern to the stippling.
- ③ Specify the spacing for the stippling.

Memo

- Touch  to create an echo quilting pattern.
Touch  to create a decorative fill pattern.

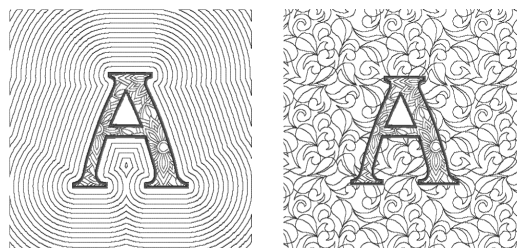

*1

*2

- *1 Echo quilting pattern
- *2 Decorative fill pattern

Embroidering a Quilting Pattern Across the Entire Fabric (Edge-to-Edge Quilt Function)

Connect quilting patterns to embroider from edge to edge of a specified area. By rehooping a large piece of fabric, you can continue embroidering the quilting pattern across the entire fabric.

■ Creating Edge-to-Edge Quilt Data

- 1 Determine the area of the fabric to be embroidered, and then draw a line around it with a chalk pencil. Measure the width and height.

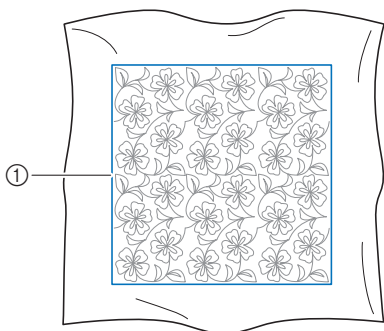

① Embroidering area

Note

- Make sure that the chalk pencil line is within the embroidering area when the fabric is hooped.

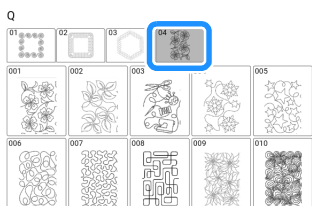

- 2 Touch , and then touch .



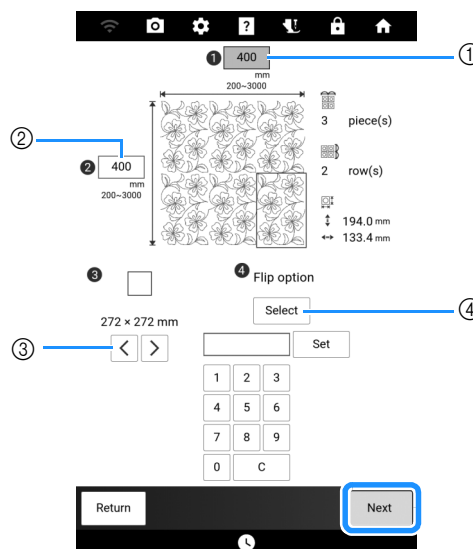

- 3 Select the pattern that you want to embroider, and then touch [Set].

- 4 Specify ① to ④, and then touch [Next].

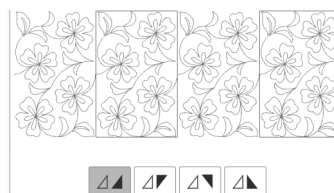

- ① Width
- ② Height
- * After entering a value, touch [Set] to apply the value. To clear the entered value, touch [C].
- ③ Touch  or  to select the embroidery frame size.
- ④ Touch [Select] to flip every other pattern. Select the desired flip arrangement (no flipping, left/right flipping, up/down flipping, left/right and up/down flipping) from the flip keys, and then touch [OK].



- 5 Check the pattern, and then touch  to save it.

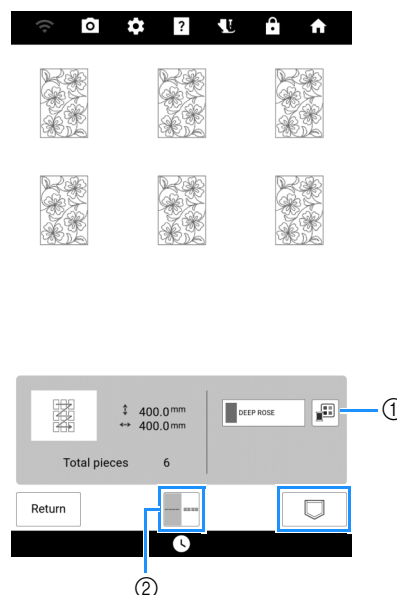

- ① The thread color can be changed.
- ② Select single stitching or triple stitching.

- 6** After the following message appears, touch [OK].

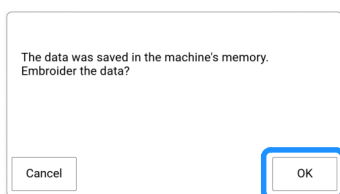

→ A screen appears so that a pattern from the machine's memory can be selected.

■ Embroidering the Edge-to-Edge Quilt Pattern

- 1** In the screen for selecting a pattern from the machine's memory, select the saved data.



- 2** For this example, since we will embroider the edge-to-edge quilt pattern according to the on-screen instructions, select the thumbnail for the entire edge-to-edge quilt pattern. And then touch [Set].

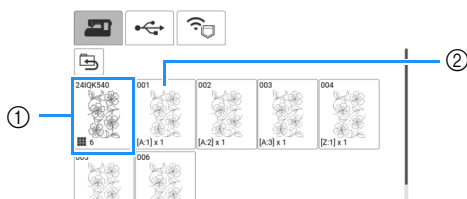

- ① Touch this key to embroider the edge-to-edge quilt pattern according to the on-screen instructions. The number in the lower-left corner indicates the total number of segments for the edge-to-edge quilt pattern.
- ② To embroider by visually aligning the pattern sections, touch each pattern section to be embroidered. You can check where and how many times the part will be embroidered with the codes written on each key. "A" refers to rows other than the last one, "Z" refers to the last row, and the numbers indicate the order in which the patterns are to be connected.

Example: When connecting patterns in 2 rows and 3 columns

A:1	A:2	A:3
Z:1	Z:2	Z:3

Example: When connecting patterns in 4 rows and 4 columns

A:1	A:2	A:3	A:4
A:1	A:2	A:3	A:4
A:1	A:2	A:3	A:4
Z:1	Z:2	Z:3	Z:4

- 3** Hoop the quilt in the embroidery frame so that the marked upper-left corner of the edge-to-edge quilt pattern is in the embroidering area, and then attach the embroidery frame.

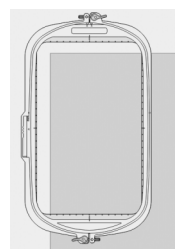

- 4** Use the move pattern keys to align the upper-left corner of the chalk reference lines previously drawn on the quilt with the upper-left corner of the part projected by the projector. Then, touch [OK].

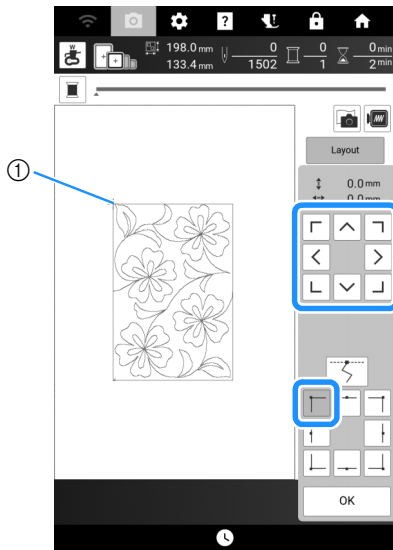

① Upper-left corner

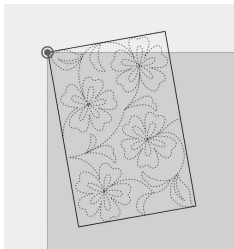

- 5** Rotate the pattern to align the upper-right corner with the chalk reference line.

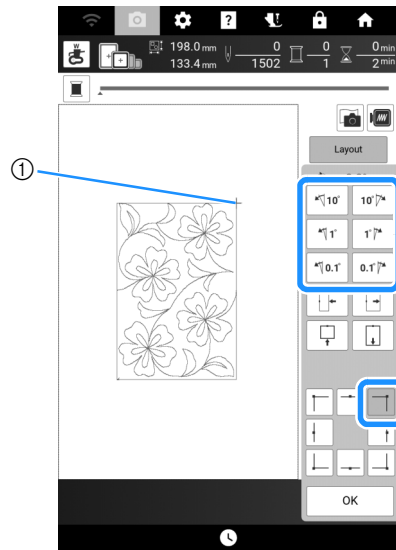

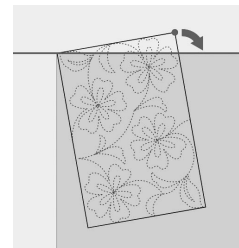

① Upper-right corner



- 6** Touch [OK] to display the embroidery screen.

Memo

- To readjust the position or angle of the pattern, touch [Layout], and then touch  or .

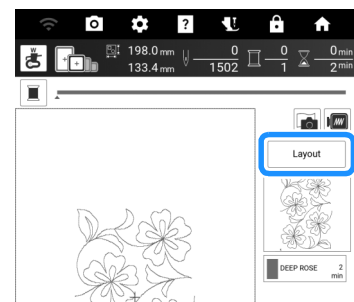

- 7** Press the “Start/Stop” button to embroider the first part.

8 When embroidering is finished and the following message appears, touch [OK].

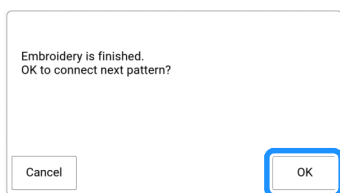

→ The next part to be embroidered appears.

9 Position each part and embroider it according to the on-screen instructions. You will be prompted to align the starting point and to rehoop the quilt when necessary.

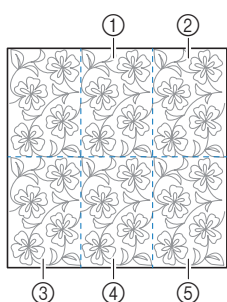

① Second column of first row ([Diagram])



Use the move pattern keys to align the start point with the end point of the previous pattern.

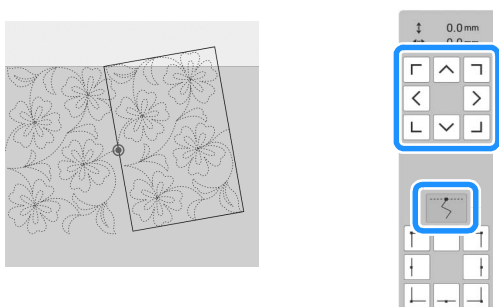

Note

- For precise positioning of the start point, rotate the handwheel toward you to check the exact needle drop point. After checking the needle position, be sure to use the needle up/down key to return the needle to its highest position.

Rotate the pattern to align the upper-right corner with the chalk reference line.

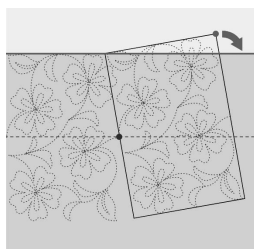

② Rightmost column of first row ([Diagram])

Use the move pattern keys to align the start point with the end point of the previous pattern.

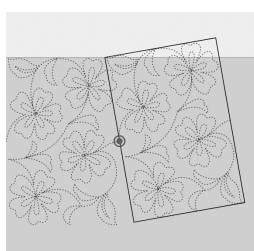

To align the upper-right corner with the chalk reference lines, adjust the angle and width of the pattern.

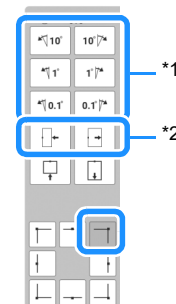
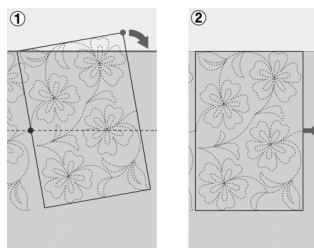

- *1 Touch to change the angle of the pattern.
- *2 Touch to change the width of the pattern.

③ Leftmost column of second row (last row) ()

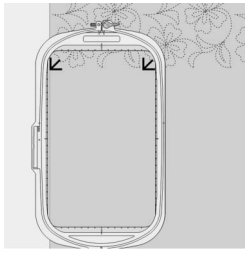

Use the move pattern keys to align the upper-left corner with the thread mark of the embroidered pattern above.

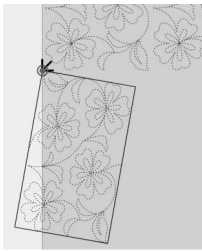

To align the upper-right corner with the thread mark of the embroidered pattern above, adjust the angle and width of the pattern.

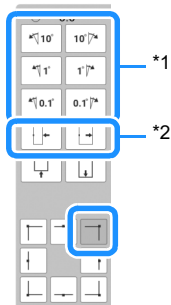
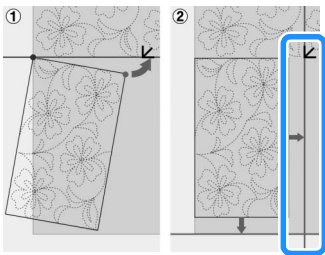

*1 Touch to change the angle of the pattern.

*2 Touch to change the width of the pattern.

Touch , and then adjust the length to align the pattern with the chalk reference line.

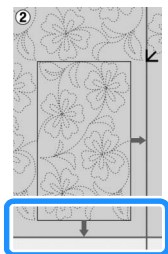

④ Second column of the second row (last row) ()

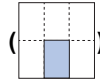

Use the move pattern keys to align the start point with the end point of the previous pattern.

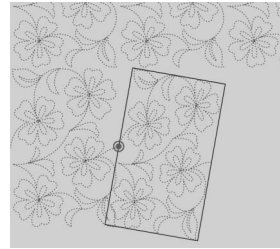

To align the upper-right corner with the thread mark of the embroidered pattern above, adjust the angle and width of the pattern.

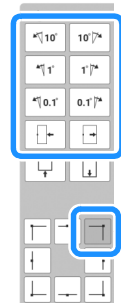
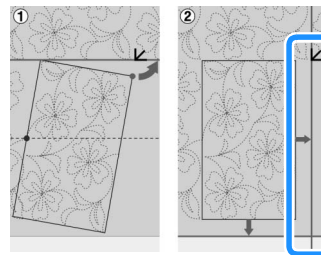

Touch , and then adjust the length to align the pattern with the chalk reference line.

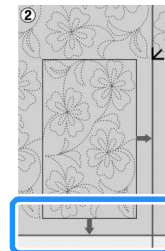

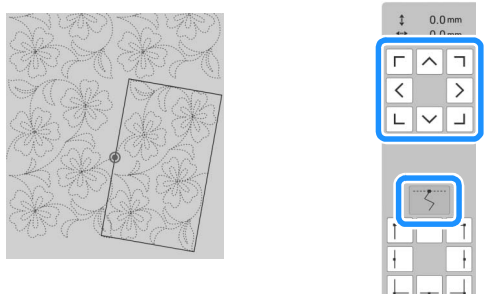

⑤ **Rightmost column of second row (last row)** ()

Use the move pattern keys to align the start point with the end point of the previous pattern.

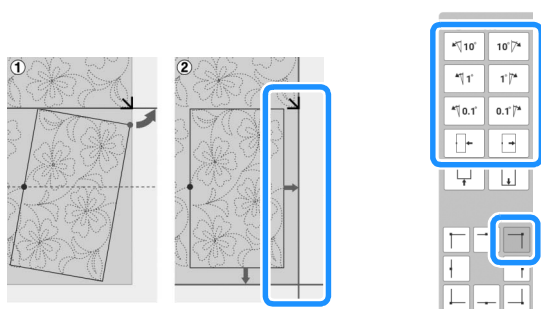

To align the upper-right corner with the thread mark of the embroidered pattern above, adjust the angle and width of the pattern.



Touch , and then adjust the length to align the pattern with the chalk reference line.

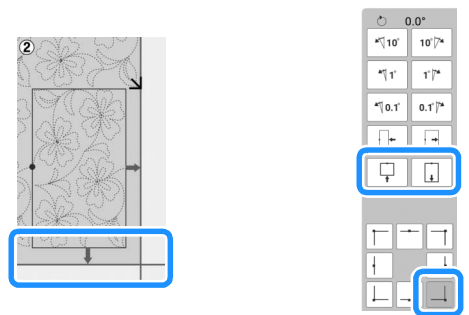

10 Remove the thread marks.

 **Memo**

- If you need to restitch a segment or skip a segment, you can touch  in the embroidery screen to continue to the next pattern or return to the previous pattern. Select the desired pattern in the embroidering order, and then touch [OK].

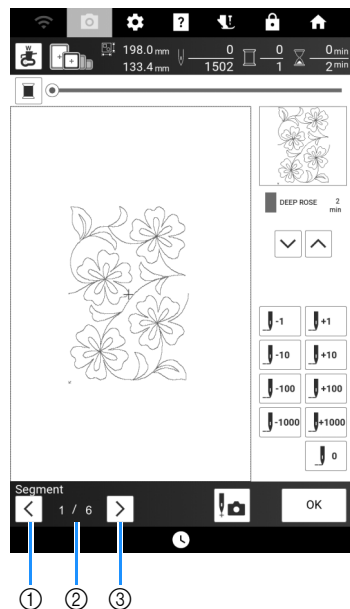

- ① Return to the previous pattern.
- ② Embroidering order of current pattern/Total number of segments
- ③ Continue to the next pattern.

Embroidering Quilting Border Patterns (Auto Split Quilt Sash)

Quilting border patterns up to 890 mm × 550 mm (approx. 35-3/64 inches × 21-21/32 inches) can be split into four sections to be stitched in the selected embroidery frame. The built-in camera will assist with placement.

It is recommended to measure the size of quilting border you want to embroider in the beginning.

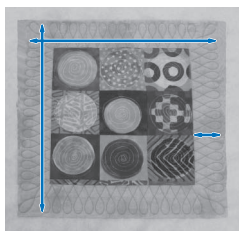

1 Touch .

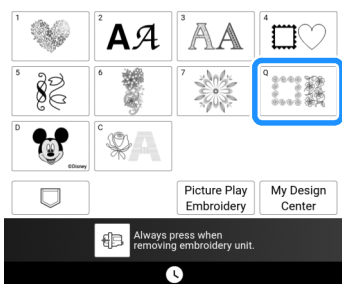

2 Select one of the rectangular quilting border categories. For this example, select single-color rectangular quilting border patterns.

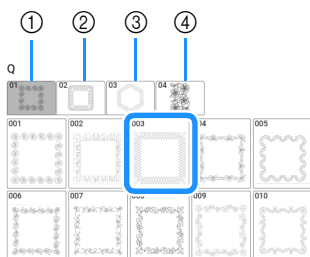

- ① Single-color rectangular quilting border patterns
- ② Two-color rectangular quilting border patterns
- ③ Hexagonal quilt border patterns
- ④ Edge-to-Edge quilt patterns

 **Memo**

- The hexagonal quilt borders patterns and edge-to-edge quilt patterns are not available for this function.

3 Select the quilt border pattern, and then touch [Set].

4 Select how to divide the pattern. For this example, select “Auto split quilt sash”.

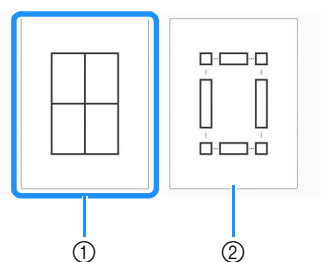

- ① Auto split quilt sash
 - ② Semi-Auto split quilt sash
- For details, refer to “Embroidering Quilting Border Patterns (Semi-Auto Split Quilt Sash)” on page 203

 **Note**

- The size of item that can be created differs depending on the type of split that was selected. Check the layout of “Auto split quilt sash”, and then select “Semi-Auto split quilt sash” if the layout did not appear as desired.

5 Specify the size of embroidery frame to be used. Enter values for the width and height of the sash and quilting border, and then touch [Set]. After entering all three values, touch [Next].

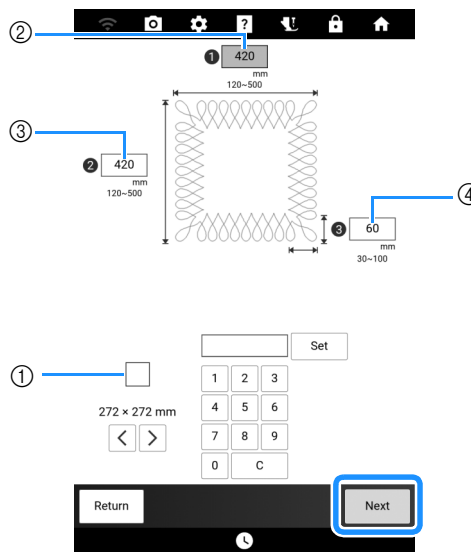

- ① Embroidery frame size
 - ② Width
 - ③ Height
 - ④ Quilting border width
- * To clear the value, touch [C].
→ The pattern appears with the specified settings applied.

6 Check the split pattern, and then touch

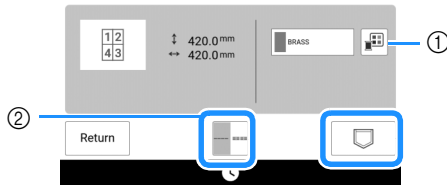
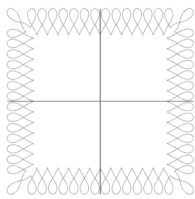

- ① You can change the thread color.
 - ② Select single stitching or triple stitching.
- The data for the split embroidery pattern is saved on the machine.

Memo

- The data for the split embroidery pattern cannot be saved on external media such as USB media.

7 To embroder the pattern, touch [OK].

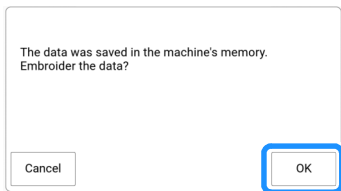

8 Select the embroidering method, and then touch [Set].

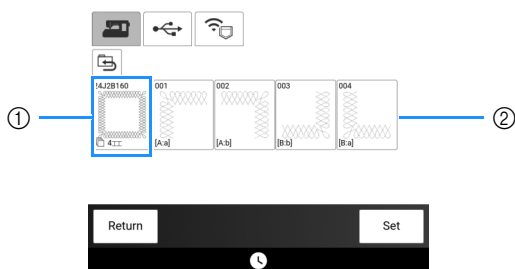

- ① To embroder using the built-in camera for aligning the embroidering position, touch the key showing the entire pattern.
 - ② To embroder by visually aligning the pattern sections, touch the pattern section to be embroidered.
- * This manual shows method ①. For method ②, refer to “Connecting the Pattern Sections Manually” on page 215.

9 Touch [Embroidery].

10 Attach the embroidery frame along with the first section being embroidered, and scan the embroidery frame. For scanning the background, refer to “Display the Fabric on the Screen” on page 157.

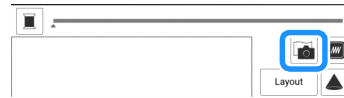

11 Move and rotate the pattern to align with the background.

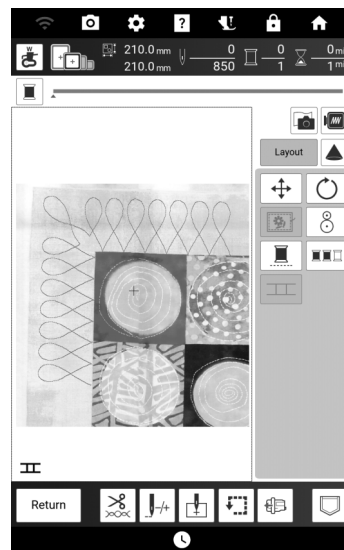

- For moving or rotating the pattern, refer to “[Layout] Window” on page 145.

12 Embroider the first section.

13 After embroidering the first section, the following message appears. Touch [OK].

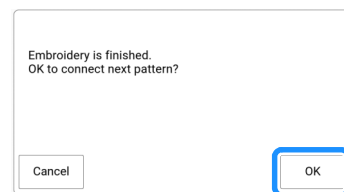

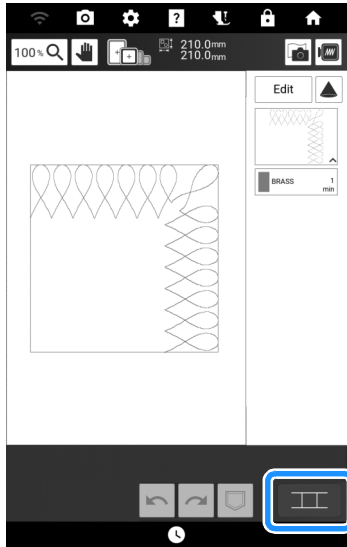
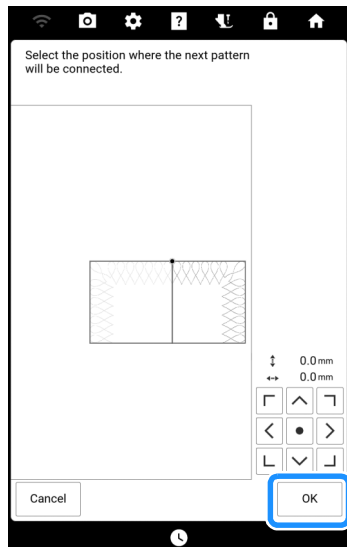
14 Touch .**15** Touch [OK].**16** Embroider the remaining sections following step 13 through 19 of “Aligning Pattern Edges” on page 217.**Embroidering Quilting Border Patterns (Semi-Auto Split Quilt Sash)**

By rehooping the fabric to embroider connecting patterns, a quilting border of up to 3 m × 3 m (approx. 118 inches × 118 inches) can be created. The pattern is positioned manually.

Creating Quilting Border Data

- 1** With a chalk pencil, mark the quilt top with the inner outline of the quilting border to be embroidered. Measure the size of the quilting border.

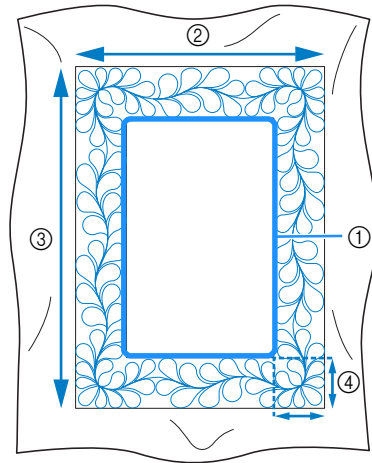

- ① Inner outline (used for positioning)
- ② Width (includes the width of borders)
- ③ Height (includes the height of borders)
- ④ Width of quilting border

Memo

- Be sure to cut the quilt layers (quilt top, batting, and quilt backing) with an excess of about 10 cm (approx. 4 inches) so that the quilt will extend to the edges of the embroidery frame.

2 Touch .

3 Select a sub-category.
For this example, select two-color rectangular quilting border patterns.

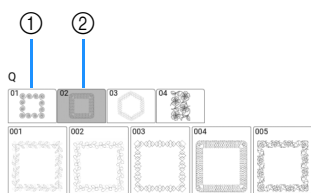

- ① Single-color rectangular quilting border patterns
- ② Two-color rectangular quilting border patterns

4 Select the pattern that you want to embroider, and then touch [Set].

5 Select how to divide the pattern. For this example, select “Semi-Auto split quilt sash”.

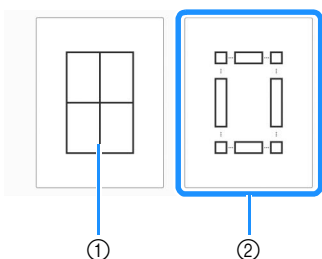

- ① Auto split quilt sash
For details, refer to “Embroidering Quilting Border Patterns (Auto Split Quilt Sash)” on page 201
- ② Semi-Auto split quilt sash

6 Specify the size of embroidery frame to be used and the size of the quilting border, and then touch [Next].

Memo

- Mark the upper-right corner of the quilt border with a chalk pencil. On the machine’s screen, enter the horizontal and vertical measurements to match the orientation of the quilt with the marked corner positioned in the upper right.

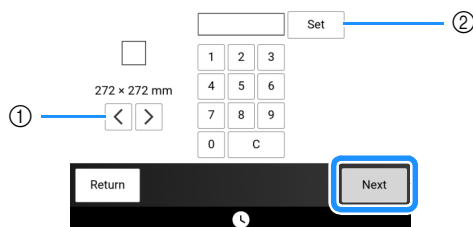
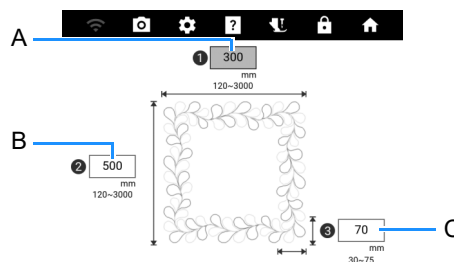

- ① Touch **<** or **>** to select the embroidery frame size.
- ② Specify the width (A), height (B) and quilting border width (C), and then touch [Set].

7 Check the pattern, and then touch to save it.

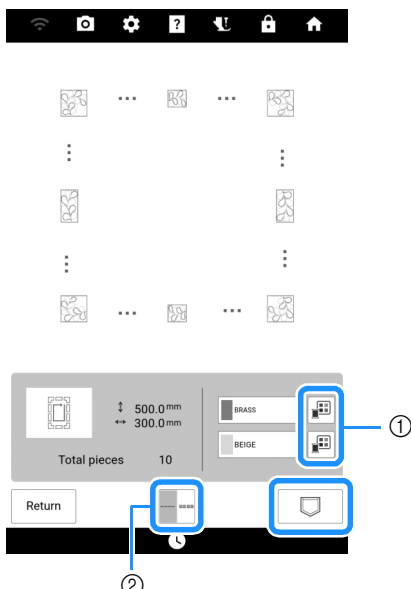

- ① The thread colors can be changed.
- ② Select single stitching or triple stitching.

Memo

- The edges of the pattern may be shortened when they are displayed.

8 After the following message appears, touch [OK].

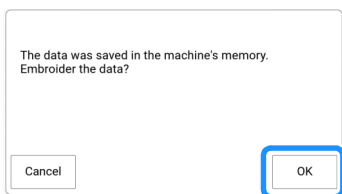

→ A screen appears so that a pattern from the machine's memory can be selected.

Embroidering a Quilting Border

1 In the screen for selecting a pattern from the machine's memory, select the saved data.

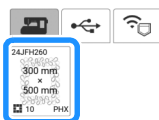

→ A thumbnail of the entire quilting border and thumbnails of the parts in each section appear.

2 For this example, since we will embroider the quilting border according to the on-screen instructions, select the thumbnail for the entire quilting border. And then touch [Set].

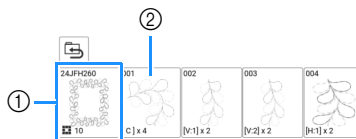

- ① Touch this key to embroider the quilting border according to the on-screen instructions. The number in the lower-left corner indicates the total number of segments for the quilt border.
- ② To embroider by visually aligning the pattern sections, touch each pattern section to be embroidered. You can check where and how many times the part will be embroidered with the codes written on each key.

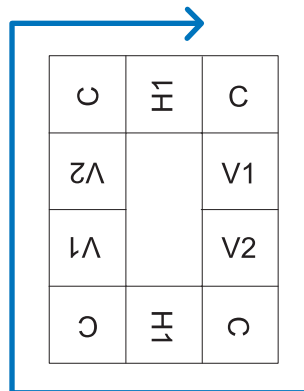

- C: Corner
- V1: The first part of the vertical side
- V2: The second part of the vertical side
- H1: The first part of the horizontal side

3 Hoop the quilt in the embroidery frame so that the marked upper-right corner of the quilting border is in the embroidering area, and then attach the embroidery frame.

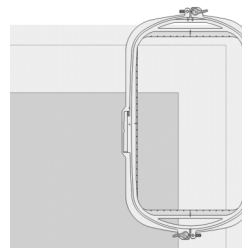

4 Align the position for the part in the upper-right corner.

With  selected, move the needle to the inner corner. Use the move pattern keys to align the inside upper-right corner of the reference lines previously drawn on the quilt with the inner corner of the part projected by the projector.

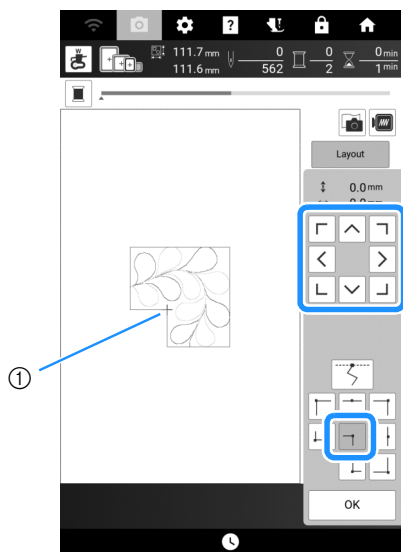

① Inner corner

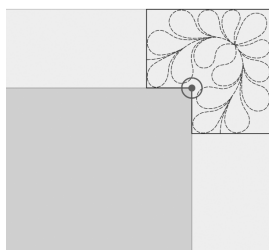

Memo

- The needle drop point projected by the projector can be corrected on the settings screen. For the procedure, refer to “Needle Calibration for Camera/Projector” on page 257.
- If necessary, rotate the pattern so that it is aligned between the chalk reference lines.

5 Touch [OK] to display the embroidery screen.

6 Press the “Start/Stop” button to embroider the first part.

7 When embroidering is finished and the following message appears, touch [OK].

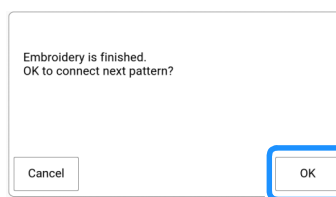

→ The next part to be embroidered appears.

8 Position each part and embroider it according to the on-screen instructions.

You will be prompted to align the starting point, rotate the design, and to rehoop the quilt when necessary.

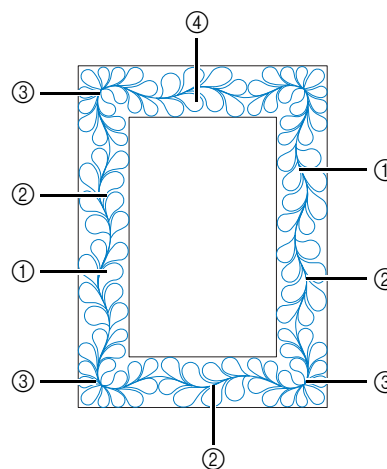

① When embroidering the edge part

Use the move pattern keys to align the start point projected by the projector with the end point of the previous pattern, and then touch [OK].

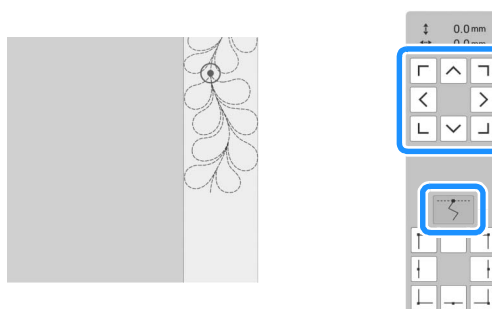

Note

- For precise positioning of the start point, rotate the handwheel toward you to check the needle drop point. After checking the needle position, be sure to use the needle up/down key to return the needle to its highest position.

Memo

- If the next pattern can be embroidered without rehooping the project, the on-screen instructions to align the start point of the pattern will not be displayed as the pattern will automatically be aligned with the start point.

Rotate the pattern to align the corner with the reference line, and then touch [OK].

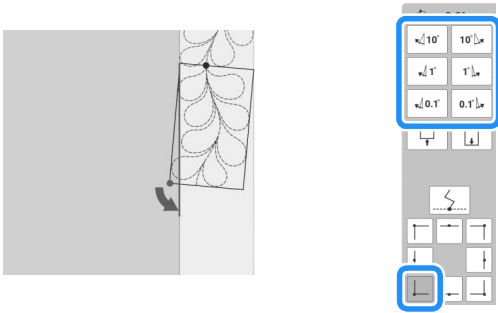

② **When embroidering the edge part immediately before a corner**

Use the move pattern keys to align the start point projected by the projector with the end point of the previous pattern, and then touch [OK].

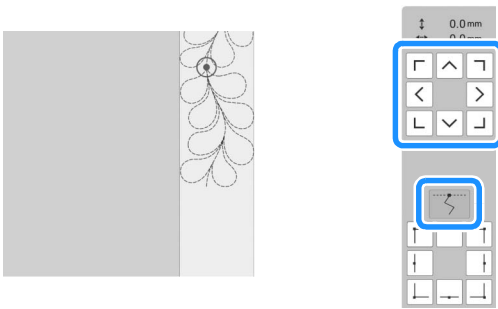

Then, align the lower-left point (inner corner of the next pattern to be embroidered) with the lower-left corner of the reference lines. If the pattern is not angled correctly, rotate it. If the length of the pattern does not match, enlarge or reduce the pattern so that the lower-left point is at the lower-left corner of the reference lines.

After making adjustments, touch [OK].

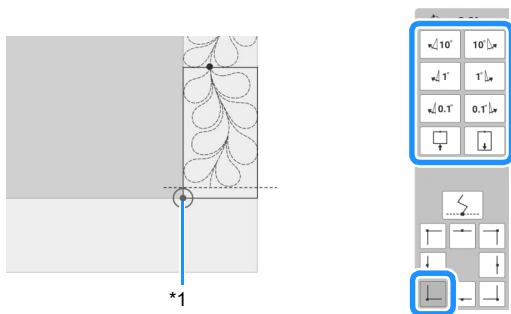

*1 Inner corner of next pattern to be embroidered

③ **When embroidering the corner part**

Rotate the quilt 90 degrees counterclockwise, rehoop it, and then attach the embroidery frame to the machine.

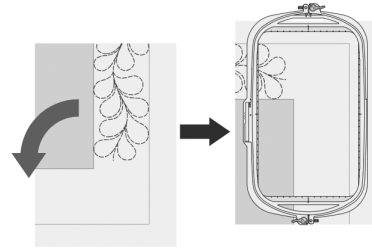

Use the move pattern keys to align the start point projected by the projector with the end point of the previous pattern, and then touch [OK].

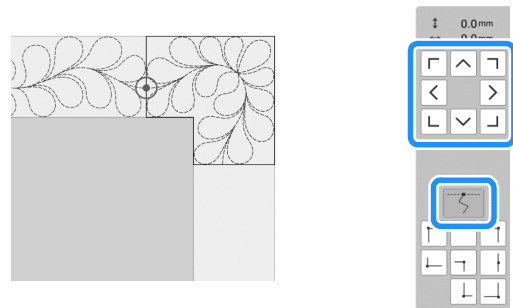

Then, align the inner corner of the pattern with the corner of the reference lines.



Memo

- The width of the corner segment can be adjusted to best fit the inner corner. However, make adjustments so that the shape is not deformed.

④ **When embroidering the last edge part**

Use the move pattern keys to align the start point projected by the projector with the end point of the previous pattern, and then touch [OK].

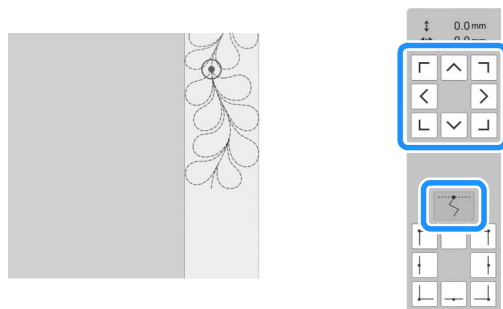

Then, align the end point of the part with the start point of the first part. If the pattern is not angled correctly, rotate it. If the length of the pattern does not match, enlarge or reduce the pattern.

After making adjustments, touch [OK].

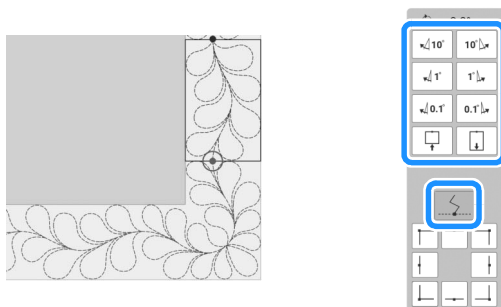

Memo

- If you need to restitch a segment or skip a segment, you can touch in the embroidery screen to continue to the next pattern or return to the previous pattern. Select the desired pattern in the embroidering order, and then touch [OK].

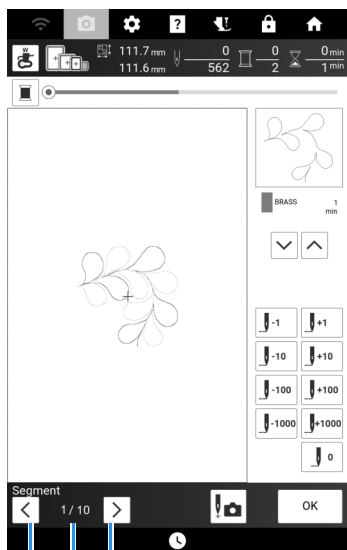

- ① Return to the previous pattern.
- ② Embroidering order of current pattern/Total number of segments
- ③ Continue to the next pattern.

Hexagonal Quilting Borders

■ Creating Quilting Border Data

- 1 With a chalk pencil, mark the quilt top with the inner outline of the quilting border to be embroidered. Measure the longest diagonal of the inner outline and the width of the quilting border.

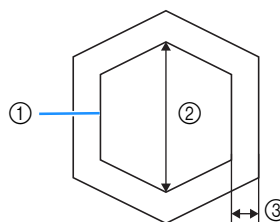

- ① Inner outline (used for positioning)
- ② Longest diagonal
- ③ Width of quilting border

Memo

- Be sure to cut the quilt layers (quilt top, batting, and quilt backing) with an excess of about 10 cm (approx. 4 inches) so that the quilt will extend to the edges of the embroidery frame.
- Hexagonal patterns can be embroidered with a diagonal width of maximum 2600 mm (approx. 102 inches) and a quilting border width of maximum 100 mm (approx. 4 inches).

- 2 Touch .

- 3 Touch .

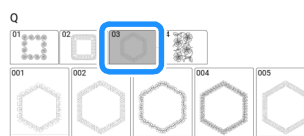

- 4 Select the pattern that you want to embroider, and then touch [Set].

5 Specify the size of embroidery frame to be used and the measurements for the quilting border, and then touch [Next].

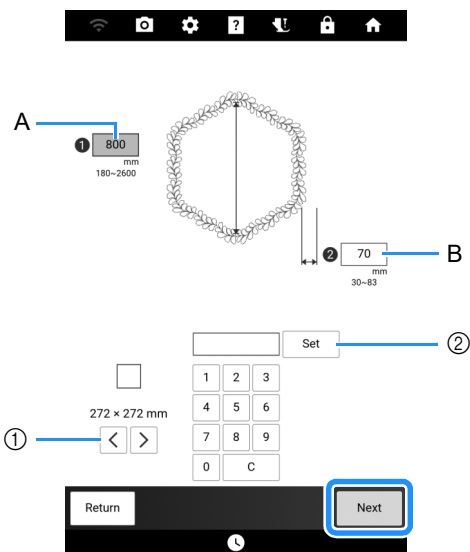

- ① Touch or to select the embroidery frame size.
- ② Specify the length of the longest diagonal for the inner outline (A) and the quilting border width (B), and then touch [Set].

6 Check the pattern, and then touch to save it.

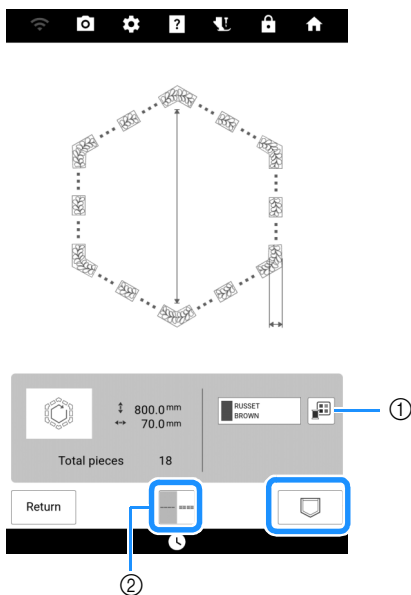

- ① The thread colors can be changed.
- ② Select single stitching or triple stitching.

Memo

- The edges of the pattern may be shortened when they are displayed.

7 After the following message appears, touch [OK].

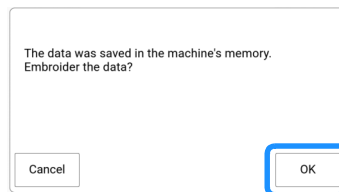

→ A screen appears so that a pattern from the machine's memory can be selected.

Embroidering a Quilting Border

1 In the screen for selecting a pattern from the machine's memory, select the saved data.



→ A thumbnail of the entire quilting border and thumbnails of the parts in each section appear.

2 For this example, since we will embroider the quilting border according to the on-screen instructions, select the thumbnail for the entire quilting border. And then touch [Set].

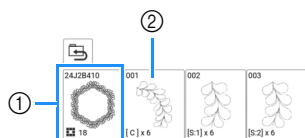

- ① Touch this key to embroider the quilting border according to the on-screen instructions. The number in the lower-left corner indicates the total number of segments for the quilt border.
- ② To embroider by visually aligning the pattern sections, touch each pattern section to be embroidered.
You can check where and how many times the part will be embroidered with the codes written on each key.

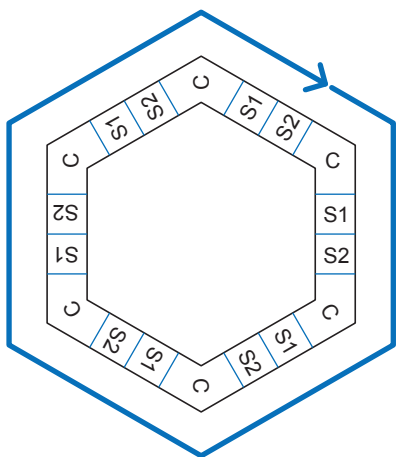

C: Corner
S: Side

3 Hoop the quilt in the embroidery frame so that the one of the corners of the quilting border is in the embroidering area, and then attach the embroidery frame.

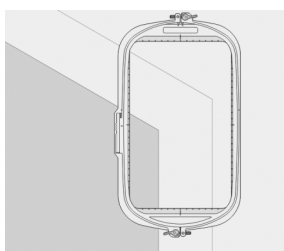

4 Align the position for the part in the corner.

Use the move pattern keys to align the inside corner of the reference lines previously drawn on the quilt with the inner corner of the part projected by the projector.

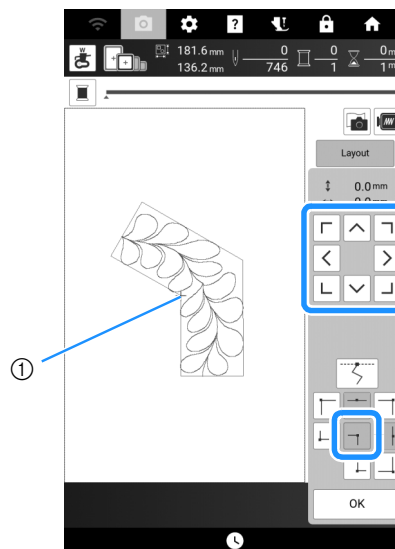

① Inner corner

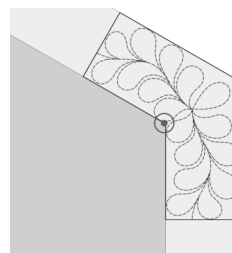

Memo

- The needle drop point projected by the projector can be corrected on the settings screen. For the procedure, refer to “Needle Calibration for Camera/Projector” on page 257.
- If necessary, rotate the pattern so that it is aligned between the chalk reference lines.

5 Touch [OK] to display the embroidery screen.

6 Press the “Start/Stop” button to embroider the first part.

7 When embroidering is finished and the following message appears, touch [OK].

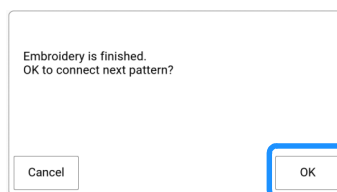

→ The next part to be embroidered appears.

8 Position each part and embroider it according to the on-screen instructions.

You will be prompted to align the starting point, rotate the design, and to rehoop the quilt when necessary.

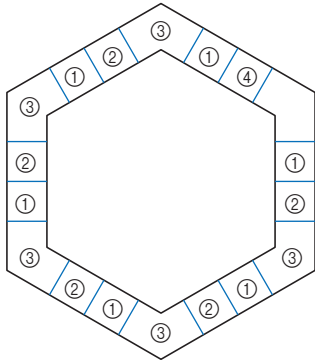

① When embroidering the edge part

Use the move pattern keys to align the start point projected by the projector with the end point of the previous pattern, and then touch [OK].

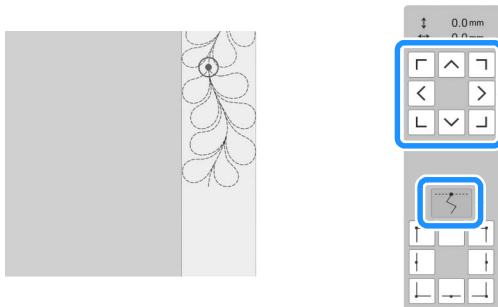

Note

- For precise positioning of the start point, rotate the handwheel toward you to check the needle drop point. After checking the needle position, be sure to use the needle up/down key to return the needle to its highest position.

Memo

- If the next pattern can be embroidered without rehooping the project, the on-screen instructions to align the start point of the pattern will not be displayed as the pattern will automatically be aligned with the start point.

Rotate the pattern to align the corner of the projected segment with the reference line on the quilt, and then touch [OK].

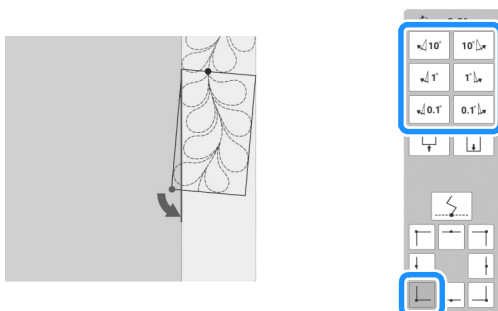

② When embroidering the edge part immediately before a corner

Use the move pattern keys to align the start point projected by the projector with the end point of the previous pattern, and then touch [OK].

Then, align the lower-left point (inner corner of the next pattern to be embroidered) with the lower-left corner of the reference lines. If the pattern is not angled correctly, rotate it. If the length of the pattern does not match, enlarge or reduce the pattern so that the lower-left point of the segment is at the lower-left corner of the reference lines on the quilt.

After making adjustments, touch [OK].

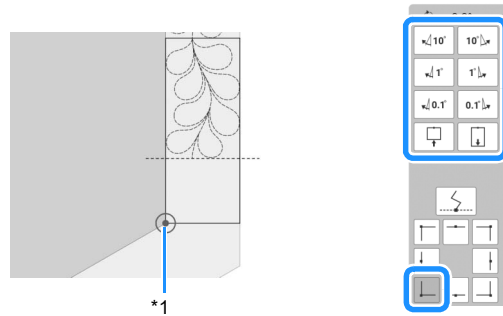

*1 Inner corner of next pattern to be embroidered

Memo

- To maintain the overall shape of the hexagon, it is important to carefully check and adjust the length of the pattern that is stitched immediately before the corner.

③ When embroidering the corner part

Rotate the quilt counterclockwise, rehoop it, and then attach the embroidery frame to the machine.

Use the move pattern keys to align the start point projected by the projector with the end point of the previous pattern, and then touch [OK].

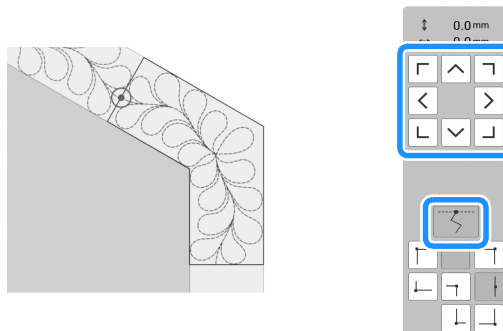

Then, align the inner corner of the pattern with the corner of the reference lines.

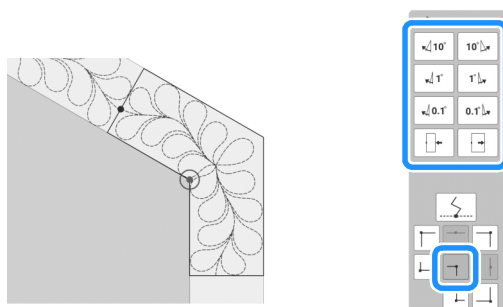

Memo

- The width of the corner segment can be adjusted to best fit the inner corner. However, make adjustments so that the shape is not deformed.

④ When embroidering the last edge part

Use the move pattern keys to align the start point projected by the projector with the end point of the previous pattern, and then touch [OK].

Then, align the end point of the part with the start point of the first part. If the pattern is not angled correctly, rotate it. If the length of the pattern does not match, enlarge or reduce the pattern.

After making adjustments, touch [OK].

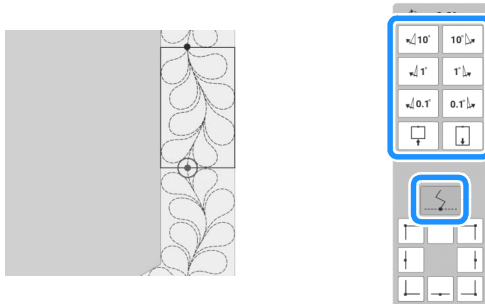

Memo

- If you need to restitch a segment or skip a segment, you can touch [↶/↷] in the embroidering screen to continue to the next pattern or return to the previous pattern. Select the desired pattern in the embroidering order, and then touch [OK].

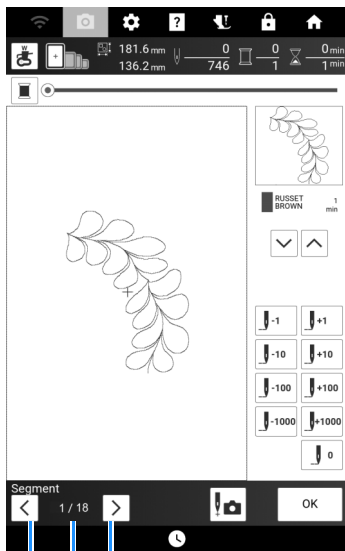

- ① Return to the previous pattern.
- ② Embroidering order of current pattern/Total number of segments
- ③ Continue to the next pattern.

Using the Camera to Connect Patterns

Embroidering Split Embroidery Patterns

This machine has several built-in large-size split embroidery patterns.

Split embroidery patterns are large patterns that are divided into multiple sections. A large pattern can be created by embroidering the connected pattern sections one after the other.

Additional split embroidery patterns can be created in PE-DESIGN version 7 or later. For details, refer to the manual for PE-DESIGN.

There are two methods: one uses the built-in camera to connect the patterns and the other connects the patterns manually.

■ Connecting the Pattern Sections with the Camera

1 Touch [Camera] and then select a pattern.

- * To ensure the entire large-connect pattern can be successfully embroidered, prepare fabric and stabilizer at least 300 mm (approx. 12 inches) longer and wider than total design size.

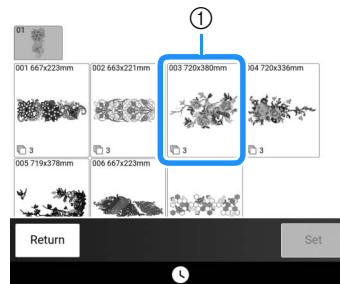
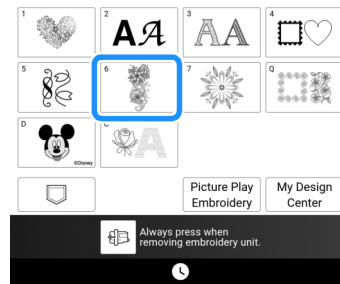

- ① Size of the entire pattern

Memo

- Printable templates of each large-connect design can be downloaded from <https://s.brother/cmdkd/>. These templates will assist with positioning the patterns. Do not enlarge or shrink the page.
- To embroider split embroidery patterns created with PE-DESIGN, retrieve the pattern from USB media and so on. For details on recalling patterns, refer to “Retrieving Embroidery Patterns” on page 168. Check the entire pattern size with PE-DESIGN.

2 Touch the whole pattern icon to connect the pattern sections with the camera. And then touch [Set].

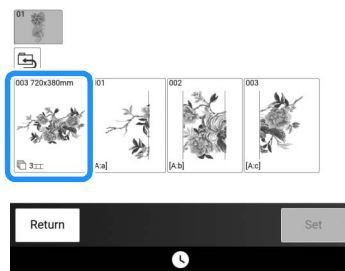

Memo

- To connect the pattern sections without using the camera, refer to “Connecting the Pattern Sections Manually” on page 215.

3 Embroider the first pattern.

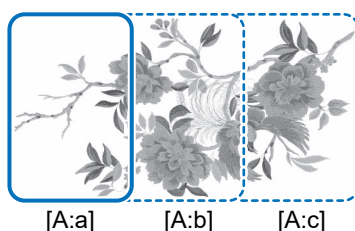
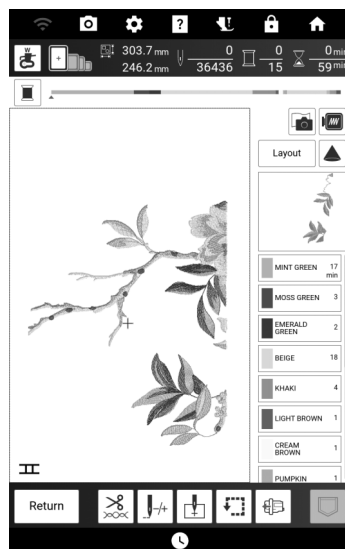

4 Touch [OK].

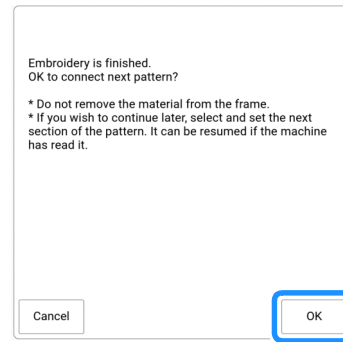

Note

- Do not remove the fabric from the embroidery frame.

5 Touch .



6 Check the pattern arrangement, and then touch [OK].

- Since each built-in pattern has been properly arranged, there is no need to move it.

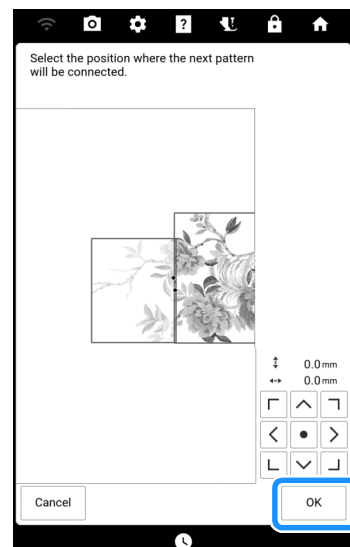

7 Touch [OK].

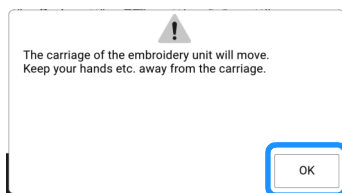

8 Affix the first embroidery positioning sticker onto the fabric within the red lines by using both hands to press down on each corner of the sticker. Affix the sticker with the large circle to the top as shown on machine. Then, touch [Scan].

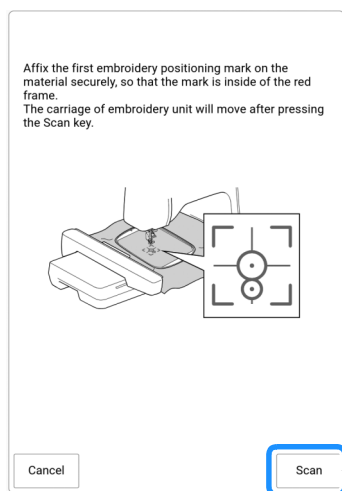

→ The camera detects the first embroidery positioning sticker.

Note

- If any of the following messages appear, reattach the embroidery positioning sticker firmly in the correct position.

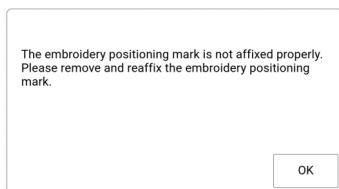
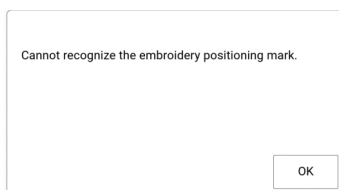

9 Affix the second embroidery positioning sticker to the fabric as described in step 8, and then touch [Scan].

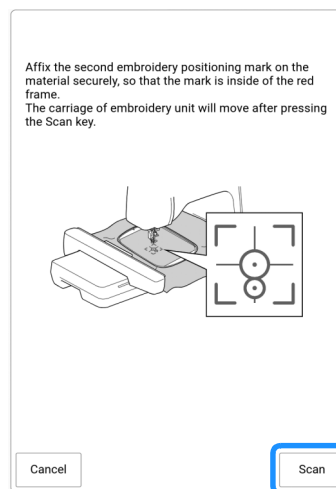

→ The camera detects the second embroidery positioning sticker.

10 While making sure that the two embroidery positioning stickers do not peel off, remove the embroidery frame from the machine, and then rehoop the fabric.

- * Be sure to hoop the fabric so the next pattern and both the embroidery positioning stickers are within the embroidery area.

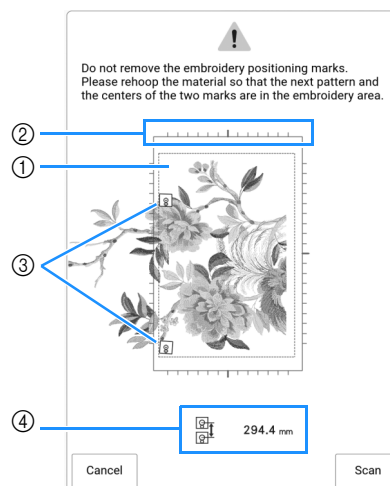

- ① Embroidery area
- ② If a built-in large-size split embroidery pattern is selected, and depending on the embroidery frame size being used, a scale may appear on the screen.
- ③ Embroidery positioning stickers
- ④ Distance between the embroidery positioning stickers

Memo

- In order to cleanly connect the first and second patterns, make sure that the distance between the embroidery positioning stickers (distance between the centers of the large circles) is the same before and after rehooping the fabric. If the distance is not the same, the fabric may not be taut. At this time, do not correct the distance by moving a sticker.

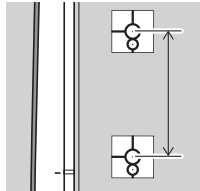

- If the following message appears after step **11**, rehoop the fabric so that the distance is the same as that displayed. And then touch [Scan].

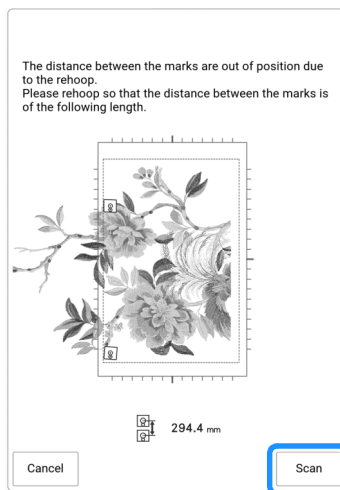

- If the following message appears, rehoop the fabric so that the next pattern and both the embroidery positioning stickers are within the embroidery area as indicated in the screen. If problem persists, the machine may not detect the embroidery positioning stickers. Check the following:
 - Make sure nothing obstructs the embroidery positioning sticker.
 - Set the fabric into the embroidery frame correctly.
 - Adjust the brightness of the lighting in the room or the machine.

Cannot recognize the embroidery positioning marks.
Please rehoop the material so that the next pattern and the centers of the two marks are in the embroidery area.

- For best results, if fabric puckers, iron the wrong side of the fabric to smooth out before rehooping. At this time, do not iron over or remove the embroidery positioning stickers.

11 Reattach the embroidery frame and touch [Scan].

12 Touch [OK], and then remove the stickers.

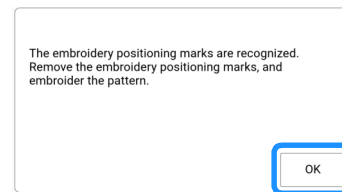

Memo

- With a built-in large-size split embroidery pattern, if the distance between the embroidery positioning stickers (distance between the centers of the large circles) differs by a few millimeters before and after the fabric is rehooped, the pattern will be automatically resized.

13 Embroider the second pattern.

14 Embroider the remaining patterns in the same way.

■ Connecting the Pattern Sections Manually

1 Touch and then select a pattern.

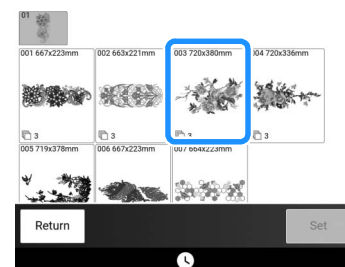

2 Select section to be embroidered.

- * Select the sections in alphabetical order.

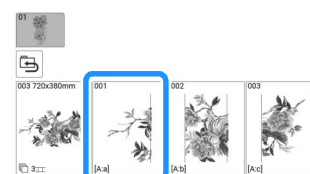

- 3** Touch [Embroidery] to display the embroidery screen.

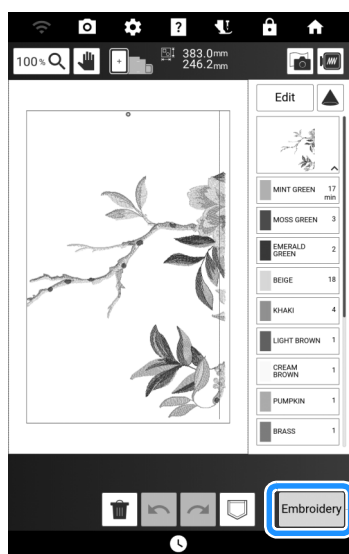

- 4** Embroider the first pattern.

→ The pattern and alignment stitching are embroidered.

- 5** Touch [OK].

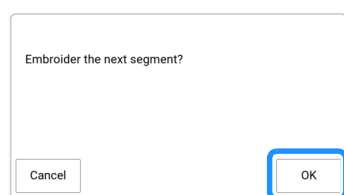

- 6** Select the next pattern, and then touch [Embroidery].

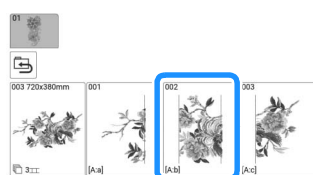

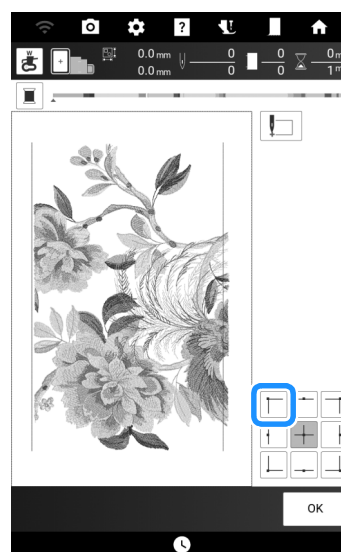
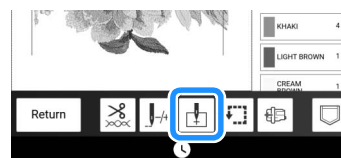

- 7** Rehoop the fabric. Adjust the position and angle for the next pattern so that the alignment stitching embroidered with the first pattern and the needle position for the next pattern are aligned. For this example, touch , select the upper-left needle position, and then touch [OK].



 **Memo**

- For best results, if fabric puckers, iron the wrong side of the fabric to smooth out before rehooping.

- 8** Touch [Layout], and then adjust the position and angle for the next pattern so that the needle position is aligned with the alignment stitching embroidered with the first pattern.

- * To adjust the position of the pattern, touch .
- * To adjust the angle of the pattern, touch .

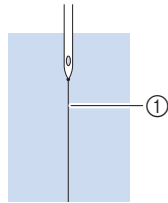

① Alignment stitching

- 9** In the same way, select the lower-left needle position, and then adjust the position and angle of the next pattern so that the needle aligns with the thread mark embroidered with the first pattern.
- 10** Embroider the second pattern.
- 11** Embroider the remaining patterns in the same way as with the second pattern.
- 12** Remove the thread marks.

Aligning Pattern Edges

Instead of using thread marks, the camera can be used to connect patterns in the embroidery screen.

Select the appropriate embroidery frame depending on the size of the embroidery. The distance between the pattern and the embroidery area of the embroidery frame must be at least 3 cm (approx. 1-3/16 inches). The small embroidery frame (2 cm × 6 cm (approx. 1 inch × 2-1/2 inches)) cannot be used with the camera function.

Example:

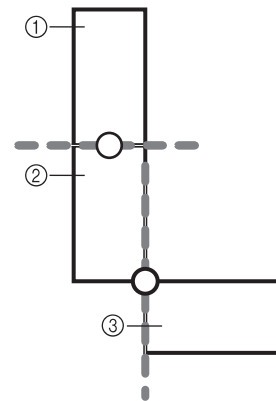

- ① Pattern A
- ② Pattern B
- ③ Pattern C

- 1** Select the first pattern A, and then touch [Set].

- * To select the desired frame pattern, refer to "Selecting Frame Patterns" on page 136.

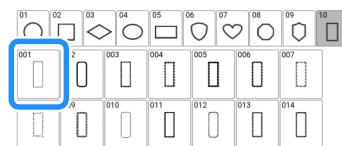

- 2** Thread the machine with the upper thread and the bobbin thread.

- 3** Hoop fabric in the embroidery frame, and then attach the frame to the machine. For this example, we will use the 18 cm × 13 cm (approx. 7 inches × 5 inches) embroidery frame.

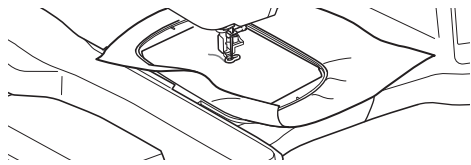

- 4** Touch [Embroidery] to display the embroidery screen.
- 5** Touch [Layout].
- 6** Touch

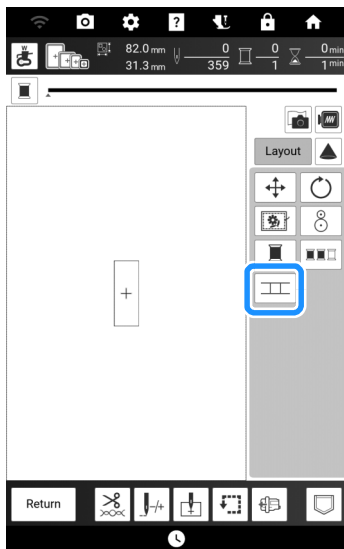

→ appears above the [Return] key, and then changes to

Memo

- can be touched while embroidering.
- A pattern cannot be saved in the machine's memory while patterns are being connected.

- 7** Lower the embroidery foot, and then embroider the first pattern.

- 8** After embroidering of the first pattern is finished, the following message appears. Touch [OK].

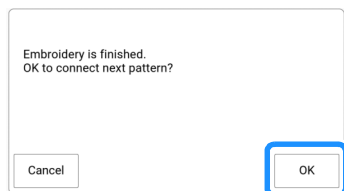

- 9** When the following message appears, touch [OK].

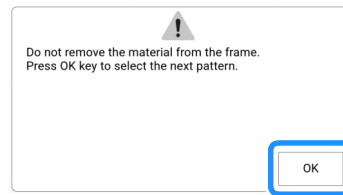

- 10** Select the second pattern B, and then touch [Set].

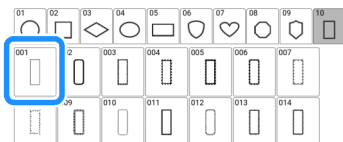

- 11** Touch , and then select how the patterns will be connected.

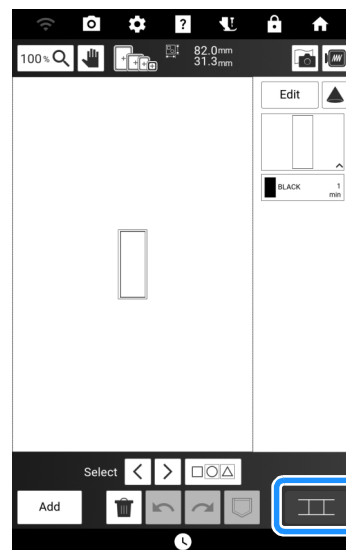

→ The pattern connection setting screen appears.

Memo

- You can edit the second pattern in this screen.

- 12** Select the position of the second pattern by touching on the screen. Touch [OK] after specifying the position.

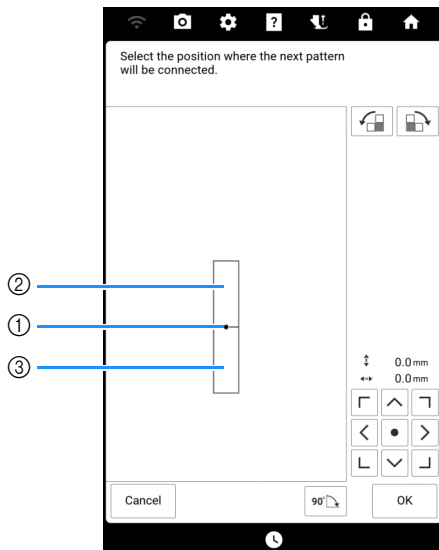

- ① Connecting point
② First pattern A
③ Second pattern B

* You can adjust the position of the second pattern using the keys described below.

	Touch to rotate the second pattern in a clockwise arc referring the first pattern as a center.
	Touch to rotate the second pattern in a counterclockwise arc referring the first pattern as a center.
	Rotate the second pattern 90 degrees in a clockwise arc.

→ Message appears on screen and carriage will move after touching [OK].

Memo

- The second pattern will be automatically connected to the first pattern without adjustment. Change the position of the second pattern manually using .
- The position of the second pattern can also be moved by dragging on the screen.

- 13** Prepare two embroidery positioning stickers. Follow the on-screen instructions to affix the two stickers to the fabric so that the positioning marks can be detected by the camera.

Note

- Use the embroidery positioning stickers included with this product or purchase replacement stickers from your authorized Brother dealer. If any other sticker is used, the camera may not recognize it.

- 14** Affix the first embroidery positioning sticker onto the fabric within the red lines that now appear on the screen of the machine by using both hands to press down on each corner of the sticker. Affix the sticker with the large circle to the top as shown on machine. Then, touch [Scan].

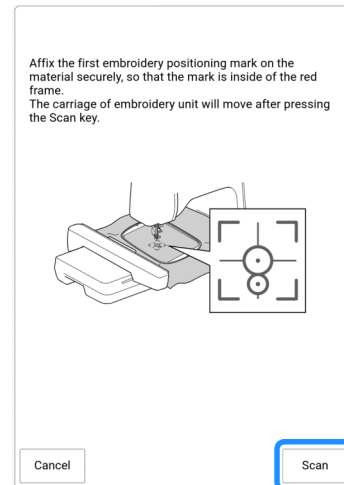

→ The camera detects the first embroidery positioning sticker.

Note

- Do not peel off the first embroidery positioning sticker to use it for the second embroidery positioning mark.
- Use new embroidery positioning stickers. If a sticker is reused, it may easily peel off. If the sticker peels off during this procedure, the patterns cannot be connected.
- Use your fingers to apply pressure to the corners of the embroidery positioning sticker to firmly affix it to the fabric. If the sticker is not firmly attached, the camera may incorrectly detect the sticker.
- If any of the following messages appear, reattach the embroidery positioning sticker in the correct position. Make sure that the sticker is affixed with the large circle at the top.

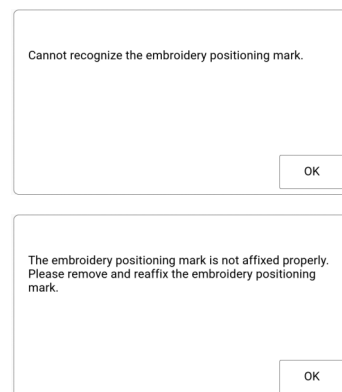

15 Use both hands to affix the second embroidery positioning mark within the red lines that now appear on the machine by pressing down on each corner of the positioning mark onto the material and then touch [Scan].

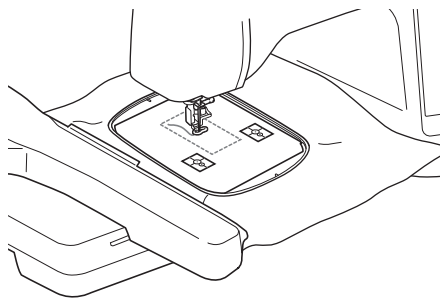
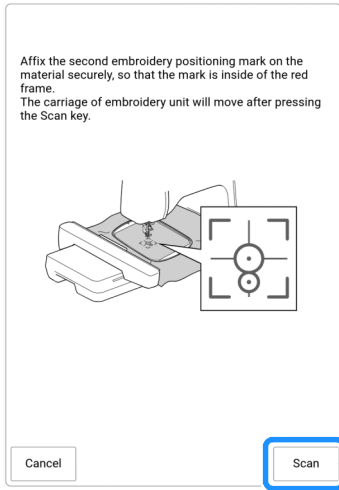

→ The camera detects the second embroidery positioning sticker. After the two embroidery positioning stickers have been detected, the following message appears.

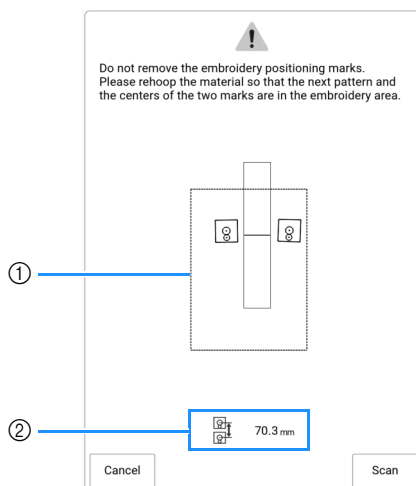

- ① Embroidering area
- ② Distance between the embroidery positioning stickers (Refer to “Memo” of step **10** of “Connecting the Pattern Sections with the Camera” on page 212)

16 While making sure that the two embroidery positioning stickers do not peel off, remove the embroidery frame from the machine, and then rehoop the fabric. Be sure to hoop the fabric so the next pattern and both the embroidery positioning stickers are within the embroidery area. Reattach the embroidery frame and touch [Scan].

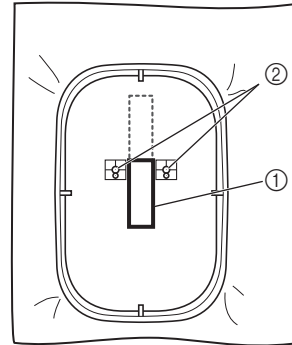

- ① Pattern to be embroidered next
- ② Centers of large circles for stickers
- The camera detects the two embroidery positioning stickers.

Note

- If either of the following messages appear, rehoop the fabric so that the next pattern and both the embroidery positioning stickers are within the embroidery area as indicated in the screen. Touch [Scan] to detect the embroidery positioning stickers.

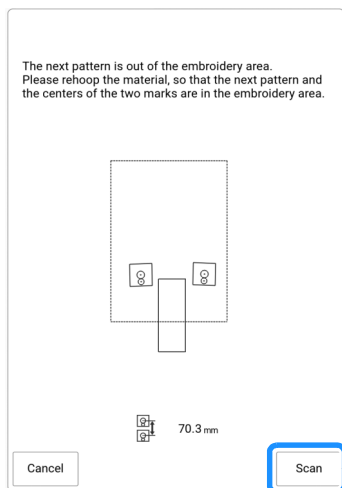
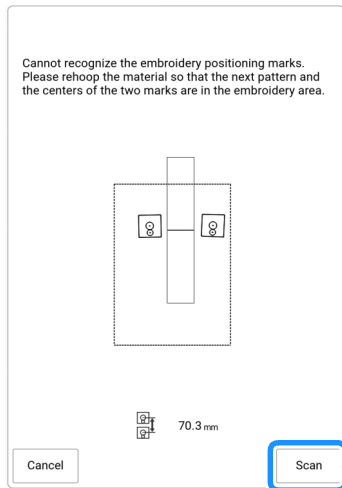

- If the machine detects that the next pattern and the centers of the large circles of the two embroidery positioning stickers do not fit within the embroidering area, the operation will be paused. Follow the on-screen instructions to reposition the embroidery positioning stickers. Refer to “Changing the Position of a Sticker” on page 222 to reposition the stickers.
- If the sticker peels off during this procedure, the patterns cannot be connected. If this occurs, restart the procedure from the beginning.
- To quit positioning, touch [Cancel].

- 17** After the embroidery positioning stickers have been detected, touch [OK], and then remove the stickers.

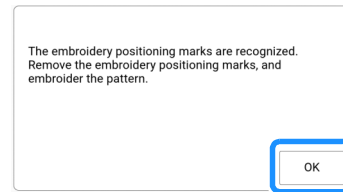

- 18** Lower the embroidery foot, and then embroider the second pattern.

- When embroidering is finished, the following message appears. To connect a third pattern, touch [OK].

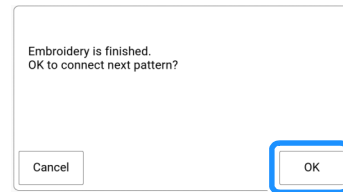

- 19** When the following message appears, touch [OK].

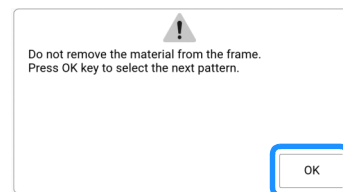

- 20** Select the third pattern C, and touch [Set].

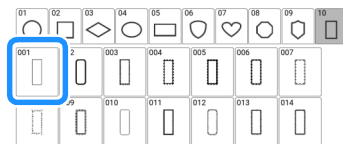



- 21** Touch , and then select how the patterns will be connected.

- The pattern connection setting screen appears.

Memo

- You can edit the pattern before selecting .

22 Specify the position of the third pattern referring to the screen display.

In this example, touch  2 times to select the connection point, and then touch . Touch [OK] after specifying the position.

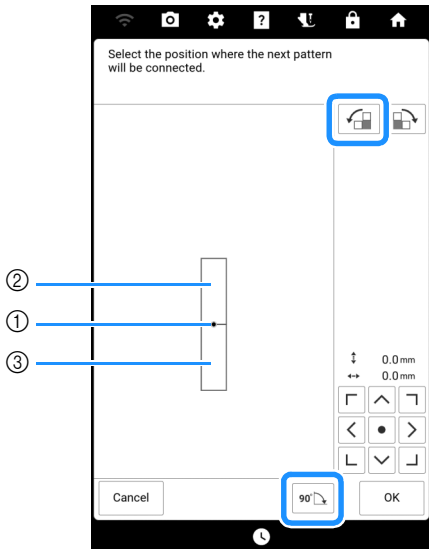

- ① Connecting point
- ② Second pattern B
- ③ Third pattern C

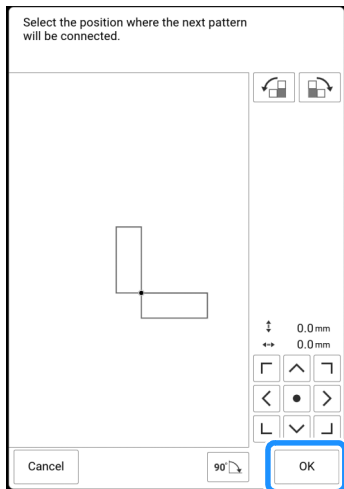



→ Message appears on screen and carriage will move after touching [OK].

Follow steps 14 through 17 of “Aligning Pattern Edges” on page 217 to position the next pattern.

23 Lower the embroidery foot, and then embroider the third pattern.

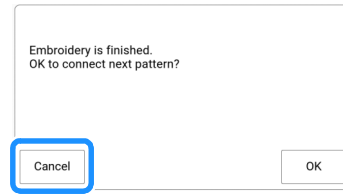
→ When embroidering is finished, the following message appears. When finished connecting patterns, touch [Cancel].



→ After embroidering is finished,  is no longer located above the [Return] key. The three patterns have been connected.

Changing the Position of a Sticker

If the selected pattern or embroidery positioning stickers for connecting the next pattern do not easily fit in the embroidering area, follow the on-screen instructions that appear after step 15 of “Aligning Pattern Edges” on page 217 in order to move the embroidery positioning stickers. For an example, the on-screen instruction appears when you use the embroidery frame with a size of 10 cm × 10 cm (approx. 4 inches × 4 inches) to connect patterns as shown below.

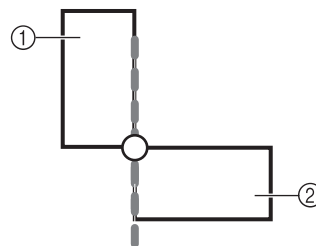

- ① Pattern A
- ② Pattern B

1 Refer to steps 1 through 15 of “Aligning Pattern Edges” on page 217 using the embroidery frame with a size of 10 cm × 10 cm (approx. 4 inches × 4 inches) to embroider the first pattern and to connect the second pattern.

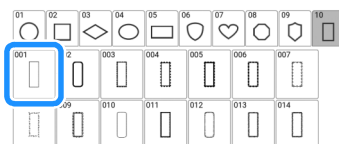

- 2** Following message appears in step 16 of “Aligning Pattern Edges” on page 217 if the next pattern or affixed embroidery positioning stickers are close to being out of the embroidering area. Follow the instructions and then touch [Scan].

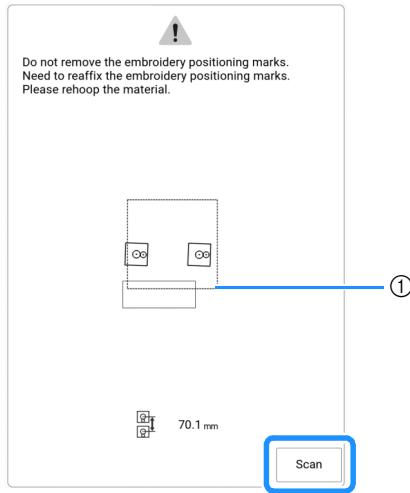

① Embroidering area

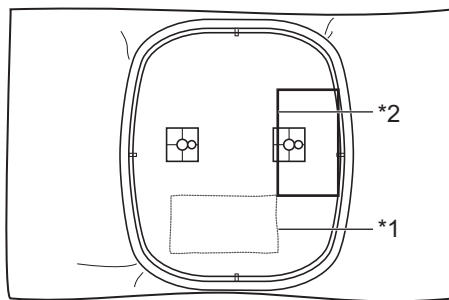

*1 First pattern that was embroidered

*2 Pattern to be embroidered next

Note

- If the following message appears, rehoop the fabric as indicated in the screen, and then touch [Scan].

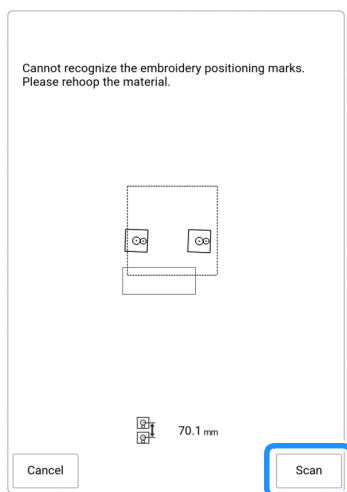

- 3** After the sticker position is detected, touch [OK], and then remove the stickers.

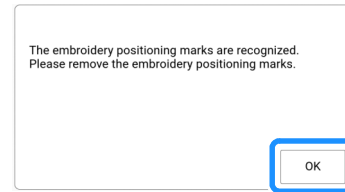

- 4** Affix the two embroidery positioning stickers again according to the on-screen instructions so that the next pattern or positioning marks can fit in the embroidery area. Affix the first sticker and then touch [Scan].

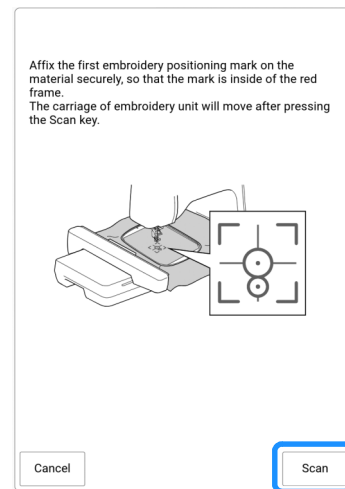

→ The camera detects the first embroidery positioning sticker.

- 5** Affix the second sticker and then touch [Scan].

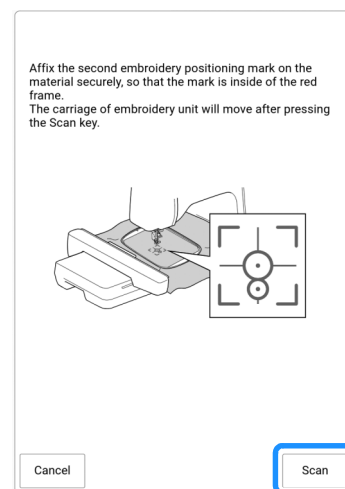

→ The camera detects the second embroidery positioning sticker.

6 After the two embroidery positioning stickers have been detected, the following message appears. While making sure that the embroidery positioning stickers do not peel off, rehoop the fabric according to the example displayed on the on-screen instruction.

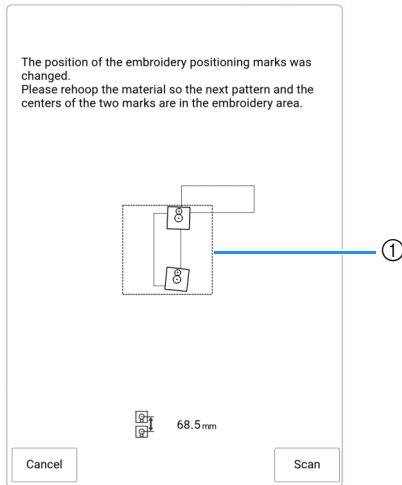

① Embroidering area

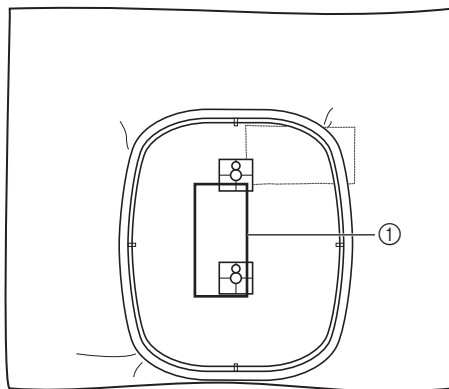

① Pattern to be embroidered next

7 Continue the operation from step 17 of “Aligning Pattern Edges” on page 217 after touching [OK].

Resume Feature

If the machine is turned off while the pattern connecting function is being used, the machine will return to the operation indicated below when it is turned on again. The machine operation will differ depending on when it is turned off.

Example: When connecting two patterns

Select the first pattern. Touch the pattern connection key . Begin embroidering the first pattern.

↓

Finish embroidering the first pattern. (A)

If the machine is turned off during any operation in this box, the machine will return to (A) when it is turned on again.

Embroidery is finished.
OK to connect next pattern?

Cancel OK

↓

Select the second pattern.

↓

Touch .

↓

Specify the reference point for connecting the pattern.

↓

Start detecting embroidery positioning stickers (2 locations).

↓

Finish detecting embroidery positioning stickers. (B)

If the machine is turned off during any operation in this box, the machine will return to (B) when it is turned on again.

Do not remove the embroidery positioning marks.
Please rehoop the material so that the next pattern and the centers of the two marks are in the embroidery area.

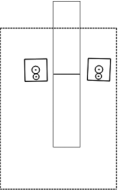

Cancel Scan

↓

Rehoop the fabric.

↓

Finish detecting embroidery positioning stickers (2 locations).

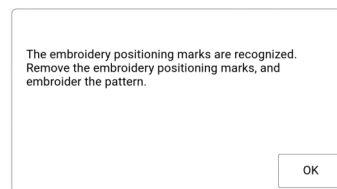

↓

Begin embroidering the second pattern.

↓

Finish embroidering the second pattern.

Using a Mobile App

My Stitch Monitor App

With the My Stitch Monitor App installed on your mobile device and the machine and mobile device connected to the same wireless network, you can check the operating status of the machine. In addition, you can receive notifications when the machine stops.

■ Installing the App

- 1 Use your smart device to scan the appropriate QR code below to visit **Google Play** or the **App Store**.



<https://s.brother/cadke/>

- 2 Install [My Stitch Monitor].



My Stitch Monitor

📖 Memo

- To download and install the app, you can also search for [My Stitch Monitor] in Google Play or the App Store.
- Visit the following web site for support information on the app.
<https://s.brother/cpdae/>

■ Monitoring

📖 Memo

- The app will be updated from time to time. The following descriptions may differ from the actual screens and operations.

- 1 **Connect the machine to your wireless network.**

* Refer to "Wireless Network Connection Functions" on page 31.

- 2 **Confirm that your mobile device and your machine are connected to the same network.**

- 3 Tap the icon for [My Stitch Monitor] on the mobile device to start the app.
- 4 Follow the instructions that appear in the app to connect the app to your machine.

* Select the name that appears beside [Machine name] in the settings screen on your machine.
→ The machine can now be monitored.

Artspira App

You can transfer content published on the app to the machine and enjoy creating original works using the functions on the app.

For more information about the app, refer to the official website.

For details on how to operate the machine using the app, see the Artspira Quick Guide on Artspira support page.



<https://s.brother/cadkg/>

My Design Snap App

Images saved on a mobile device can be transferred to the machine so that an embroidery pattern can be created.

■ Installing the My Design Snap App

- 1 Use your smart device to scan the appropriate QR code below to visit **Google Play** or the **App Store**.



<https://s.brother/cadkf/>

2 Install [My Design Snap].



My Design Snap

Memo

- To download and install the app, you can also search for [My Design Snap] in Google Play or the App Store.
- Visit the following web site for support information on the app.
<https://s.brother/cpdae/>

■ Transferring an Image from a Mobile Device to the Machine

Memo

- The app will be updated from time to time. The following descriptions may differ from the actual screens and operations.

1 Connect the machine to your wireless network.

- * Refer to “Wireless Network Connection Functions” on page 31.

2 Confirm that your mobile device and your machine are connected to the same network.

3 Tap the icon on the mobile device for [My Design Snap] to start the app.

4 Follow the instructions that appear in the app to connect the app to your machine.

- * Select the name that appears beside [Machine name] in the settings screen on your machine.

5 Tap .

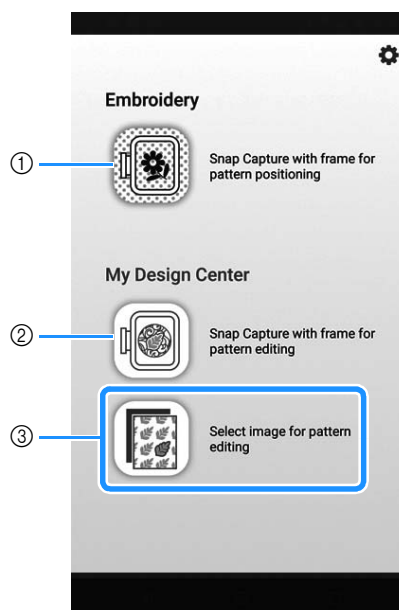

- ① This icon is not available for your machine. It is for machines that are not equipped with a camera. Your machine will use the built-in camera to align embroidery patterns. For details, refer to “Display the Fabric on the Screen” on page 157.
- ② This icon is not available for your machine. It is for machines that are not equipped with a camera. Your machine will use the built-in camera to create embroidery patterns in My Design Center. For details, refer to “Create the Pattern Using Scanned Images or Image Data Files” on page 241.
- ③ This icon allows you to transfer an image from the mobile device to the machine to create a design.

6 Select the image, then select [Send to the Machine] to transfer it from the mobile device to the machine.

- You will receive confirmation in the app that the image was successfully sent to the machine.

Memo

- To retrieve the transferred images, refer to each function.
 - Picture Play embroidery function (page 177)
 - My Design Center (page 241)

Chapter 6 My Design Center

About My Design Center

With My Design Center, you can use the functions listed below:

- Creating embroidery patterns by drawing on the LCD screen or by using built-in stamps or shapes.
- Creating embroidery patterns by not only scanning drawings /illustrations with built-in camera, but also importing data from USB media.
- Creating embroidery patterns by sending images from your mobile device to your machine
- Setting the stitch types, fill stitch types and colors for created patterns.
- Combining patterns that you have created with the machine's built-in patterns.

Start My Design Center by touching [My Design Center] in the home page screen or touching [My Design Center] in the embroidery pattern selection screen.

Before Creating Designs

The pattern preview displays the design smaller than the actual size. You can view the actual pattern size by setting the [Embroidery Frame Display].

- 1 Touch  to display [Embroidery Frame Display] of the settings screen.
- 2 Select the grid line and embroidery frame.

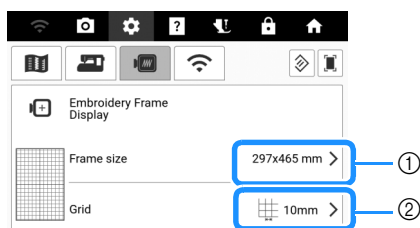

- ① Embroidery frame types
- ② Grid types

Create a Stippling Design with the Basic Procedure

Example:

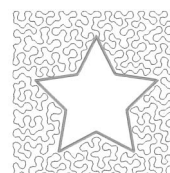

- 1 Start [My Design Center] and touch .

* For details on this screen, refer to "Pattern Drawing Screen" on page 230.

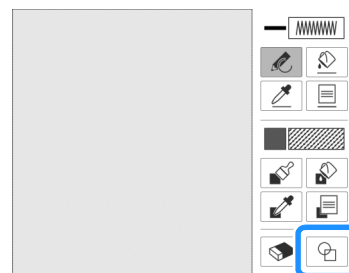

- 2 Touch  and select the frame embroidering area. And then touch [OK].

* You can also select the various shapes by touching .

* For details on this screen, refer to "Using the Stamp Key" on page 231.

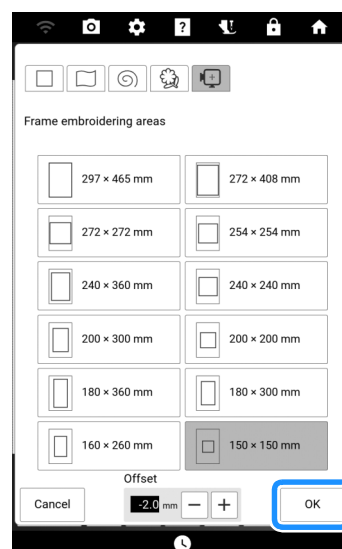

- 3 Touch .

4 Select the desired shape, and then touch [OK].

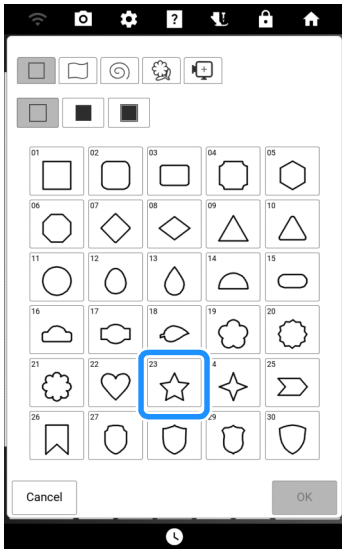

5 Touch .

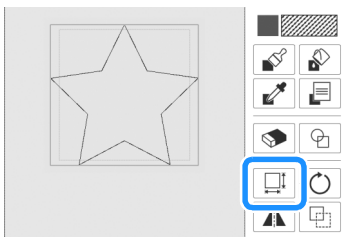

6 Select the direction in which to change the size, and then touch [OK].

* For details on this, refer to "Using the Size Key" on page 236.

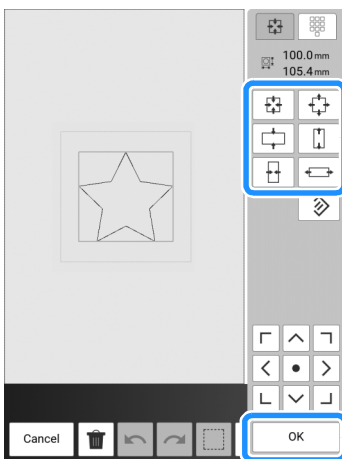

7 Touch .

8 Select the stitch type and the stitch color, and then touch [OK].

* For details on this screen, refer to "Setting the Line Types, Stitch Types and Colors" on page 233.

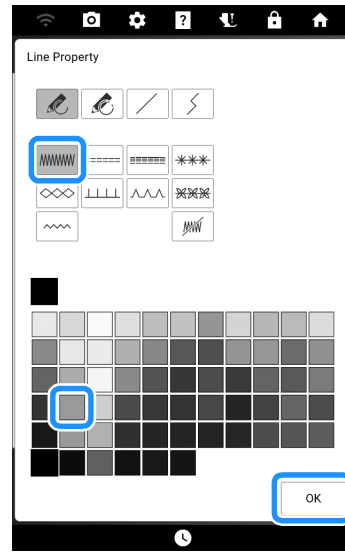

9 Touch  and then touch the shape.

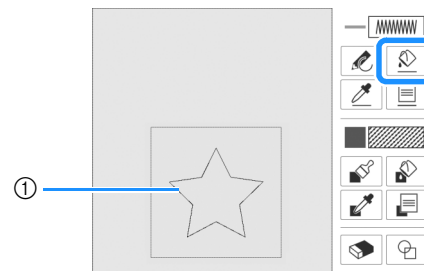

① Shape

10 To set the stippling stitch color and fill stitch type, touch .



11 Touch , and then select the stitch color. And then touch [OK].

* For details on this screen, refer to “Setting the Brush Types, Fill Stitch Types and Fill Colors” on page 234.

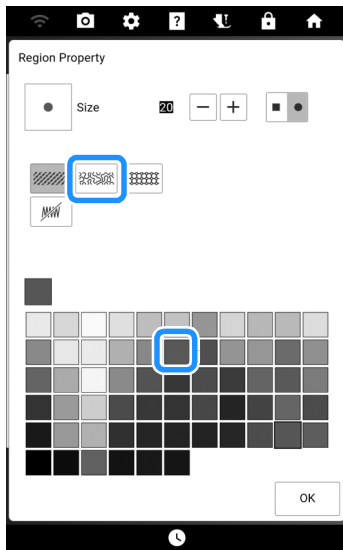

12 Touch , and then touch the area you want to set stippling effect.

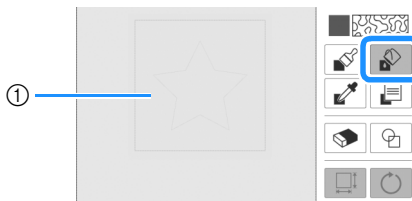

① Area where stippling is applied

13 Touch [Next].

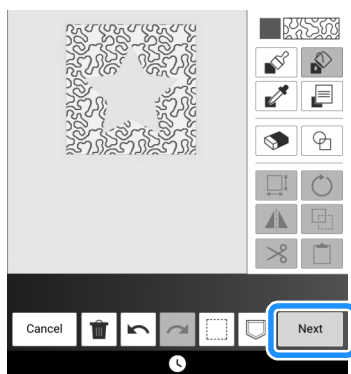

14 Adjust the stippling settings, and then touch [Set].

* For details, refer to “Region Settings” on page 240.

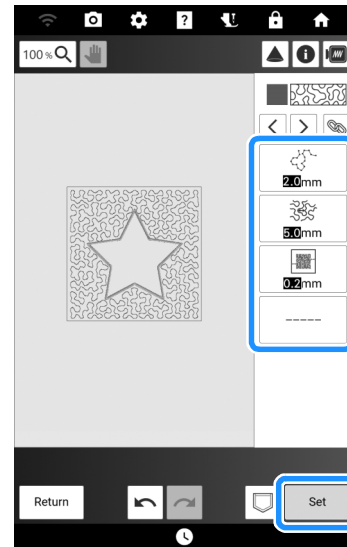

→ The embroidery edit screen appears after touching [OK].

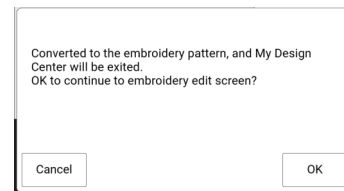

15 If necessary, touch [Edit] to edit the selected pattern. (page 142)

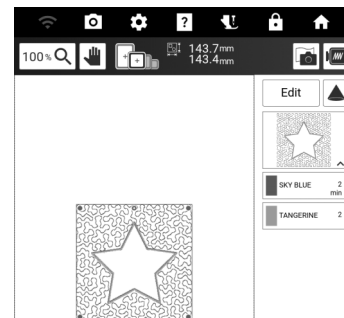

16 Touch [Embroidery]. And then start embroidering. (page 140)

Key Functions (My Design Center)



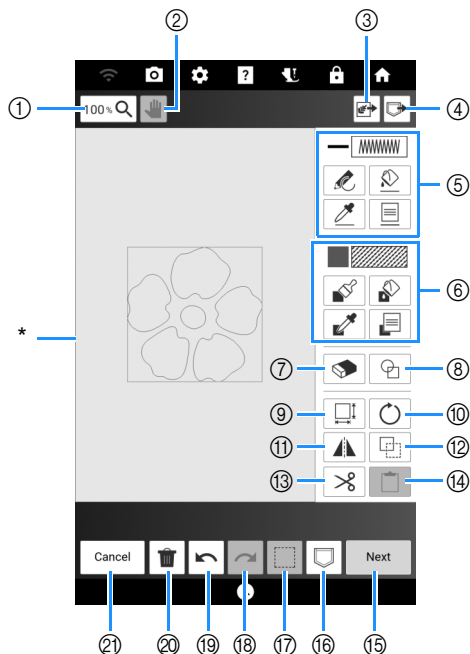



Pattern Drawing Screen



* Pattern drawing area

No.	Display	Explanation	Reference
	Name		
①		Magnify the pattern.	—
	Magnify key		
②		Move the canvas when it is magnified.	—
	Hand tool key		
③		Create patterns using scanned images, line drawings, illustrations, and data files of images.	241
	Scan/Design key		
④		Recall pattern drawing data created with My Design Center from the machine's memory, or USB media.	—
	Recall key		

No.	Display	Explanation	Reference		
	Name				
⑤		Display the color and stitch type specified in the [Line Property] screen.	233		
	Line display				
				Draw lines. Specify the line type in the [Line Property] screen.	232
	Line tool key				
				Apply the color and stitch type specified in the [Line Property] screen to the selected line.	233
	Bucket tool key for line				
				Pick up the color and stitch type from a line in the pattern. The picked-up color and stitch type are reflected in the [Line Property] screen.	—
Dropper tool key for line					
⑥		Display the [Line Property] screen. Set the line type, stitch type, and color.	233		
	Line Property key				
⑥		Display the fill color and fill stitch type specified in the [Region Property] screen.	234		
	Region display				
				Paint with a brush. Specify the brush shape and size in the [Region Property] screen.	232
	Region tool key				
				Apply the color and fill stitch type set in the [Region Property] screen to brush lines and the closed area made from the lines.	234
	Bucket tool key for region				
				Pick up the fill color and fill stitch types from a region in the pattern. The picked-up fill color and fill stitch type are reflected in the [Region Property] screen.	—
Dropper tool key for region					
	Display the [Region Property] screen. Set the brush type, fill stitch type, and fill color.	234			
⑦		Erase lines and shapes that have been drawn. You can select the size/shape of the eraser.	235		
	Eraser key				
⑧		Select the stamp shape for pattern drawing.	231		
	Stamp shapes key				
⑨		Change the size of the selected section.	236		
	Size key				
⑩		Rotate the selected section.	—		
	Rotate key				
⑪		Flip the selected section horizontally.	—		
	Mirror image key				
⑫		Duplicate the selected section.	—		
	Duplicate key				
⑬		Cut out the selected section.	—		
	Cut key				
⑭		Paste in the previously duplicated or cut section.	—		
	Paste key				

No.	Display	Explanation	Reference
	Name		
15		Proceed to the stitch settings screen. (page 238)	—
	Next key		
16		Save the pattern drawing data.	—
	Memory key		
17		Select a section for editing.	235
	Select key		
18		Redo the operation that was undone with the undo key. Each touch of this key will redo one operation.	—
	Redo key		
19		Undo the last operation that was performed and return to the previous state. Each touch of this key will undo one operation.	—
	Undo key		
20		Clear all the lines and shapes and start from the beginning. The background image is also cleared.	—
	All Clear key		
21		Exit from My Design Center. All lines and shapes are erased when you touch this key.	—
	Cancel key		

Memo

- For information on the file extensions for pattern drawing data, refer to “Specifications” on page 271.

Using the Stamp Key

1 Touch .



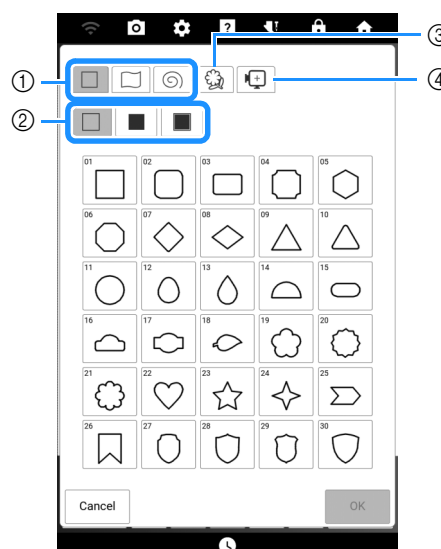

2 Select a stamp type and stamp shape.





- ① Stamp shapes
- ② Stamp types
- ③ Saved outlines
- ④ Frame embroidering areas

• Stamp shapes

	Basic shapes
	Closed shapes
	Open shapes

• Stamp types (Only for Basic shapes)

	Outline
	Fill stitch
	Outline and fill stitch

• Saved outlines

	Embroidery pattern outlines can be registered as stamp shapes. When registering stamp shapes, select from the last 20 embroidery patterns used. If more than 20 shapes are registered, the oldest one is automatically erased. For details on registering a stamp shape, refer to “Decorative Stitching Around a Pattern” on page 249.
---	--

• Frame embroidering areas

	Select an embroidering area in order to arrange the pattern to fit an embroidery frame. If an offset value is specified, a shape offset to the inside is displayed. When making a frame pattern using a motif stitch, etc., specify an offset value according to the pattern size so the pattern can fit within the embroidering area for the selected embroidery frame.
---	--



3 Touch [OK] to set the selected stamp.

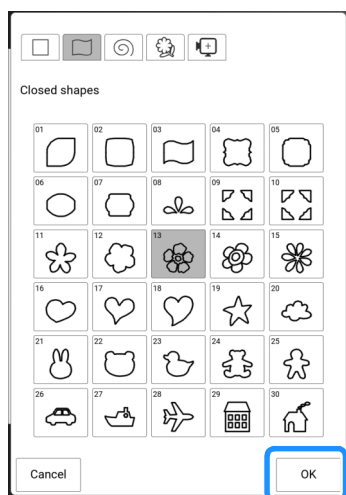

4 Edit the design with available keys.

* For details, refer to "Pattern Drawing Screen" on page 230.

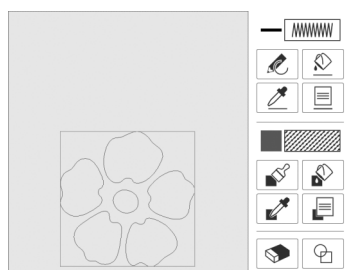

5 Touch [Next], and then specify the stitch setting.

* For details, refer to "Specifying Individual Stitch Settings" on page 238.

Drawing Lines

1 Touch [Memo] to set the line types, stitch types and colors. (page 233)

2 Touch the draw key and draw lines.

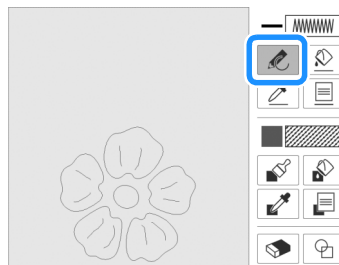

Memo

- When the draw key is touched, all regions will be displayed in the background to clarify the drawing lines on the screen.

3 Touch [Next], and then specify the stitch setting. (page 238)

Drawing Regions

1 Touch [Next] to set the brush types, fill stitch types and fill colors. (page 234)

2 Touch [Brush] and draw with brush.

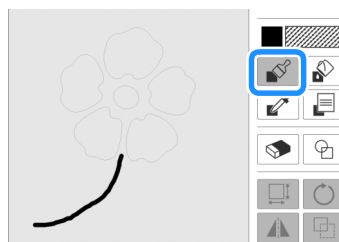

3 Touch [Next], and then specify the stitch setting. (page 238)

Setting the Line Types, Stitch Types and Colors

You can set or change the line types, stitch types and colors anytime. You can also specify the settings before drawing lines.

- 1 Touch  to set the line types, stitch types and colors.

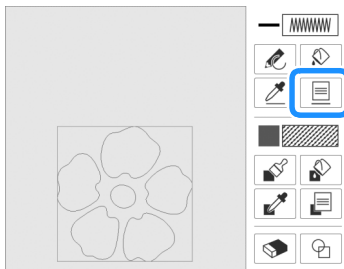



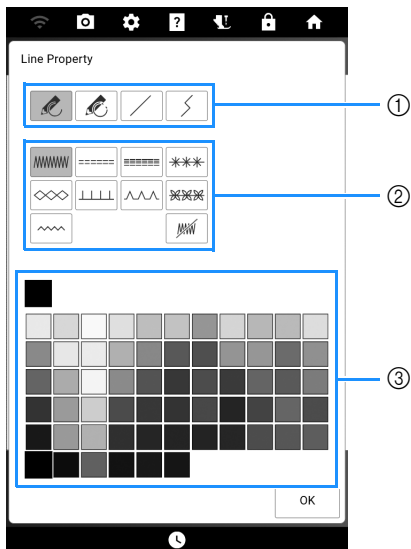

→ The [Line Property] screen appears.













- ① Line types
- ② Stitch types
- ③ Line color selection: touch the color palette to activate the drawing pen color.

• Line types

	Freehand line with the end open.
	Freehand line closing the end automatically.
	Straight line with one stroke.
	Straight line changing directions to the point you select. If the end point is created near the start point, a closed object will be created.

• Stitch types

	Zigzag stitch
	Running stitch
	Triple stitch
	Candlewicking stitch
	Chain stitch
	E stitch
	V stitch
	Select motif stitches Displays motif stitch selection screen, where <input type="button" value="Select"/> can be touched to select a pattern.
	Appliqué zigzag stitch
	Line without stitch for creating a region. Created region will be defined by the gray line.

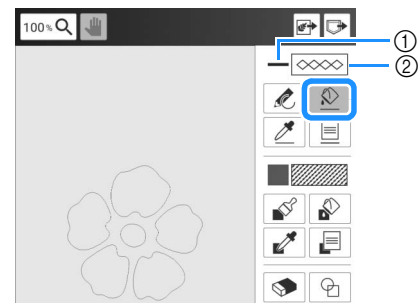

- 2 Touch [OK] to return to the pattern drawing screen.

- 3 Touch  then touch on the lines to change the settings.



- ① Color
- ② Stitch type

Memo

- The appearance of the line does not change even if the stitch type was changed. The specified stitch type can be checked in the stitch settings screen. (page 238)
- Touch  to magnify the image when you cannot touch on the line correctly.
- Touching , then touching a line reflects the settings for that line in the [Line Property] screen.

Setting the Brush Types, Fill Stitch Types and Fill Colors

- 1 Touch  to set the brush types, fill stitch types and fill colors.

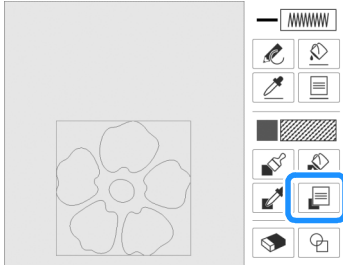



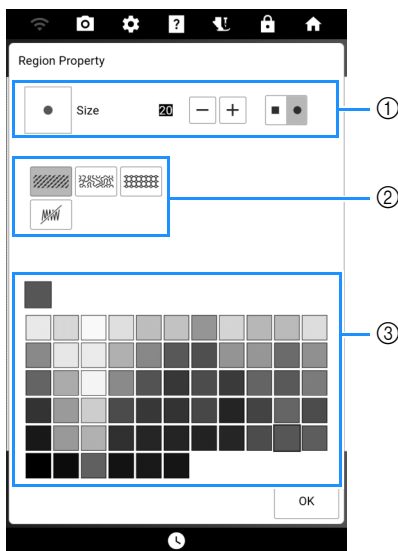



→ The [Region Property] screen appears.







- ① Brush types
- ② Fill stitch types
- ③ Fill color selection: touch the color palette to activate the paint brush color.

• Brush shapes

To select the brush size, touch  or .

	Square brush	
	Round brush	

• Fill stitch types

	Fill stitch pattern
	Stippling pattern
	Select decorative fill patterns Displays a fill pattern selection screen, where  can be touched to select a pattern.
	Select this key when you do not want fill stitches.

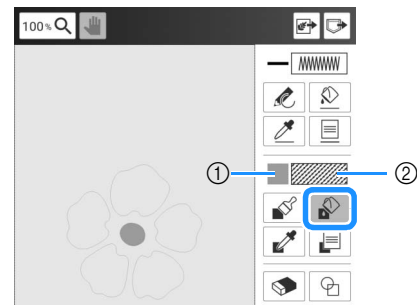

- 2 Touch [OK] to return to the pattern drawing screen.

- 3 Touch  and touch on the regions to change fill color and fill stitch types.



- ① Color
- ② Stitch type

Memo

- Touch  to magnify the image when you cannot touch on the fill correctly.
- Touching , then touching a region reflects the settings for that region in the [Region Property] screen.

Using the Select Key



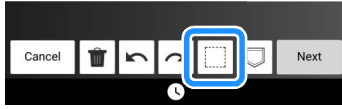

You can select the part of the design to move and/or edit.

1 Touch .





2 Select the method for selecting an area. And then touch [Close].



	Box selection	Selects all objects within the box that is drawn.
	Polygonal shape selection	Selects all objects within the polygonal shape that is drawn. Draw a polygon by touching the screen to add points, and then specify the end point by touching the red square at the starting point.
	Freestyle curve selection	Selects all objects within the curved line that is drawn.
	Automatic selection	Selects the pattern that is touched. This allows you to select only a single line or only the outer pattern of a donut shape.
	Select all	Selects all patterns.

3 Select the area you want to edit.

- * Create the red box around your selected area to be edited.
- * To select the desired pattern easily, magnify the image. Touch  to magnify the pattern and use  to move the canvas.

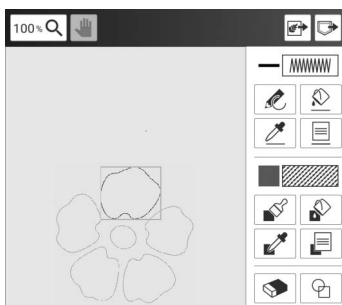

4 Edit the design with available keys. (page 230)



5 Touch [Next], and then specify the stitch setting. (page 238)

Using the Erase Key

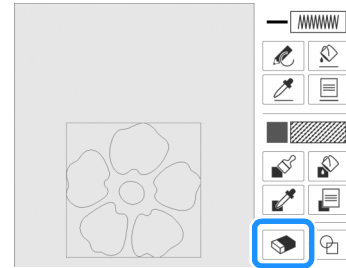
1 Touch .



2 Select the shape of the eraser. And then drag along the area or line that you want to erase.

- * To select the eraser size, touch  or .

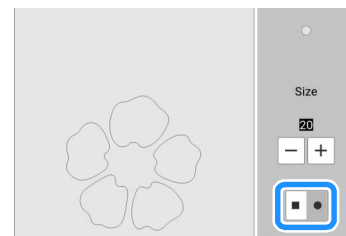

3 Touch [OK].

Memo

- The area or lines can be erased while the key appears as .

Using the Size Key

1 Touch .

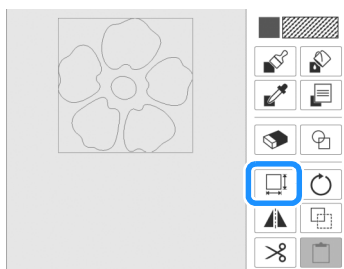

2 Select the direction in which to change the size.

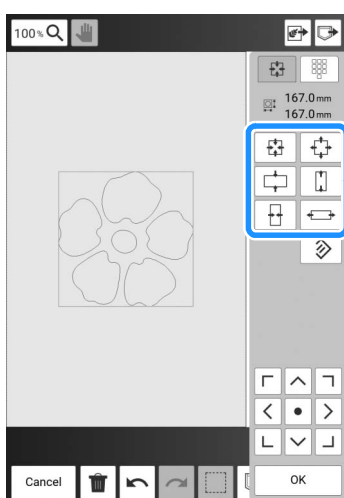

Memo

- To specify the size by number, touch . Touch the box for the height or width, specify a value with the number keys, and then touch [Set].

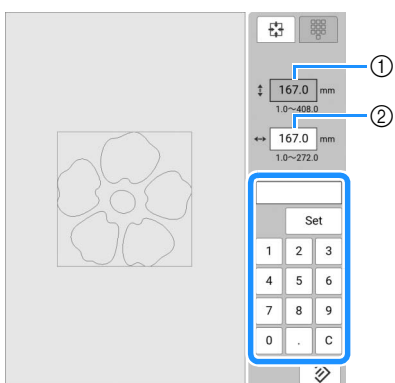

- ① Box for height
- ② Box for width

3 Touch [OK].

Importing Motif Stitch Pattern Data or Decorative Fill Pattern Data

Motif stitch pattern data or decorative fill pattern data created in [Programmable Stitch Creator] of PE-DESIGN can be imported into My Design Center.

- * Motif stitch pattern data can be created on PE-DESIGN version 4 or later. Decorative fill pattern can be created on PE-DESIGN version 11 or later.
- * For information on the file extensions for motif stitch pattern data and decorative fill pattern data, refer to "Specifications" on page 271.

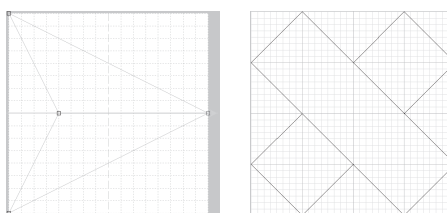

1 Save the motif stitch pattern data and/or decorative fill pattern data in the USB media.

2 Insert the USB media into the USB port on the machine.

3 Touch [My Design Center].

4 To import motif stitch pattern data, touch . After [Line Property] screen appears, touch , then [Select].

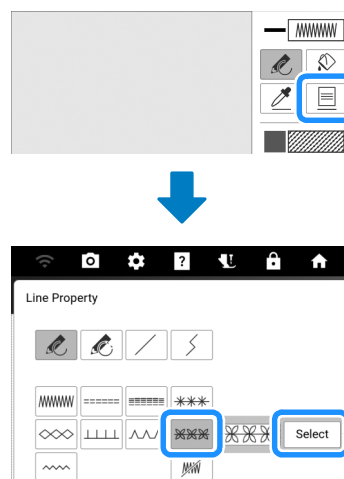

5 Touch [Custom], then .



6 Select the motif stitch pattern data, and then touch [OK].

- * If two USB media are connected to the machine, check the USB media names that are displayed, and then touch the name of the USB media that you wish to use.



→ The motif stitch pattern data is saved to the machine.

7 Select the motif stitch pattern to be used, and then touch [OK].

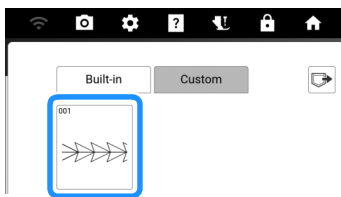

Memo

- Saved motif stitch patterns are assigned a pattern number. The pattern number appears in the upper-left corner of the key.
- Up to 12 motif stitch patterns can be saved to the machine. When trying to save more motif stitch pattern data than this maximum, a message will appear. Follow the on-screen instructions, and select the pattern number of the motif stitch pattern data to be replaced.
- Touch [Clear all] to delete all saved motif stitch pattern data.

8 To import decorative fill pattern data, touch [Import]. After [Region Property] screen appears, touch [Select], then [Select].

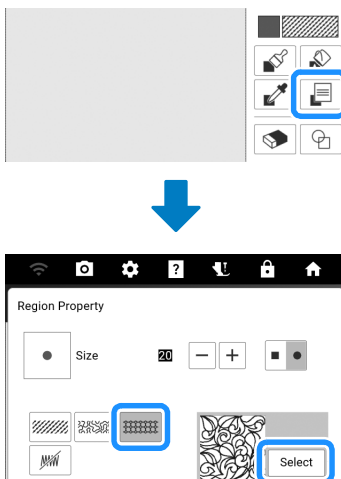

9 Refer to steps 5 through 7 to select an imported decorative fill pattern.

10 Edit the pattern. If necessary, touch [OK] to save the pattern.

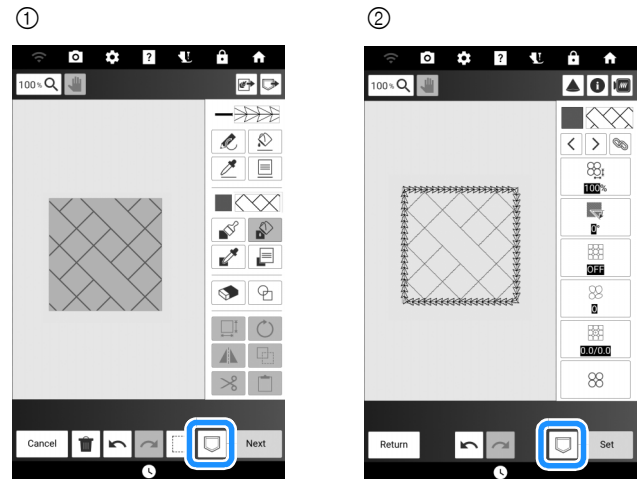

- ① Pattern drawing screen
- ② Stitch settings screen

Memo

- When saving a pattern (that contains an imported motif stitch pattern or decorative fill pattern) as pattern drawing data, it can only be saved in the machine's memory.
- When recalling a saved design, the motif stitch pattern or decorative fill pattern currently saved under the assigned pattern number is imported. (If the custom stitch pattern that was assigned to a saved design has been replaced by another custom stitch pattern, the original stitch pattern will not be recalled. It will be replaced with the replacement stitch pattern.)
- If all custom stitch patterns are cleared, the custom stitch pattern that was assigned to a saved design will not be recalled. It will be replaced with a default stitch pattern. Patterns with deleted custom motif patterns will be recalled with a zigzag stitch. Patterns with deleted custom decorative fill patterns will be recalled with a standard fill stitch.
- If the design is saved on the embroidery edit screen after touching [Set] on stitch settings screen, the custom motif and decorative fill pattern will be preserved.

Stitch Settings Screen

After creating the pattern drawing data in the pattern drawing screen (page 230), you will have an opportunity to:

- Check and change the stitch settings for each line and region.
- Save the pattern drawing data.
- Convert the data to an embroidery pattern, proceed to the embroidery edit screen, and/or save the embroidery pattern.

Specifying Individual Stitch Settings

Select a pattern in the stitch settings screen to specify its line and region stitch settings.

1 Use to select the line or region to be changed.

→ Each touch of moves the highlighting of the selected pattern in order.

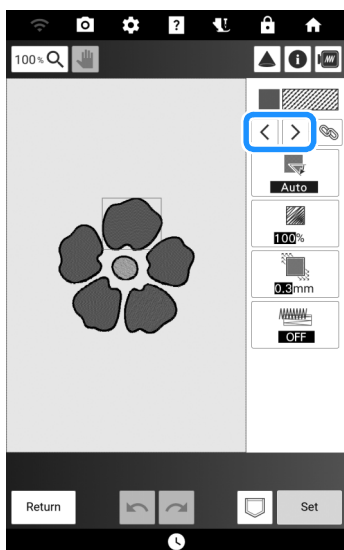

2 Select the setting to be changed, and then change the setting in the screen that appears. (In this example, the embroidering direction will be changed.)

* For details on each setting, refer to “Line and Region Settings” on page 239.



3 Touch [Manual], and then use to change the direction.

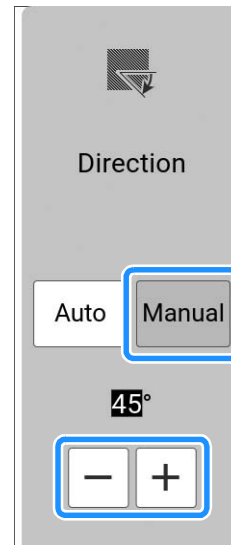

4 Touch [OK] to apply the setting.

* Change other settings in the same way.

5 If necessary, touch to save the pattern.

6 Touch [Set] to convert work into an embroidery pattern.

→ The embroidery edit screen appears after touching [OK].

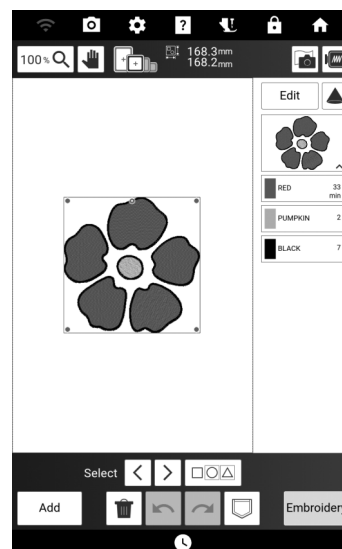

Memo

- To combine the patterns created in [My Design Center], touch [Add], and then touch [My Design Center].

Line and Region Settings

Line Settings

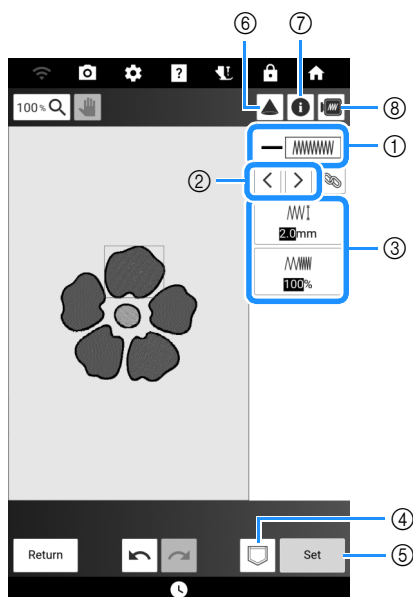

- ① Shows/Changes the stitch type and color for the selected line.
- ② Select the line to be changed.
- ③ Shows/Changes the stitch settings for the selected line.
- ④ Save the pattern drawing data and embroidery data.
- ⑤ Proceed to embroidery edit screen.
- ⑥ Use the projector to project the pattern. (page 154)
- ⑦ See detailed information about the pattern.
- ⑧ Preview the pattern.

Line stitch settings

Zigzag stitch /

Appliqué zigzag stitch

[Zigzag width]	Specifies the width of the stitch.
[Density]	Specifies the density of the stitch.

Running stitch /

Triple stitch

[Run Pitch]	Specifies the length of the stitch.
[Under sewing]	Select if you need or do not need the under sewing for the stabilized fabric.

Candlewicking stitch

[Size]	Increases/reduces the size of the pattern.
[Spacing]	Specifies the spacing of the candlewicking stitch.

Chain stitch

[Size]	Increases/reduces the size of the pattern.
[Thickness]	Sets repeated embroidering at the same part.

E stitch

[Stitch Width]	Increases/reduces the size of the pattern.
[Spacing]	Specifies the spacing of the E stitch.
[Thickness]	Sets repeated embroidering at the same part.
[Flip]	Specifies if the decorative line shows up inside or outside.

V stitch

[Stitch Width]	Increases/reduces the size of the pattern.
[Spacing]	Specifies the spacing of the V stitch.
[Thickness]	Sets repeated embroidering at the same part.
[Flip]	Specifies if the decorative line shows up inside or outside.

Motif stitches

[Size]	Increases/reduces the size of the pattern.
[Spacing]	Specifies the spacing of the motif stitch.
[Flip]	Specifies if the decorative line shows up inside or outside.



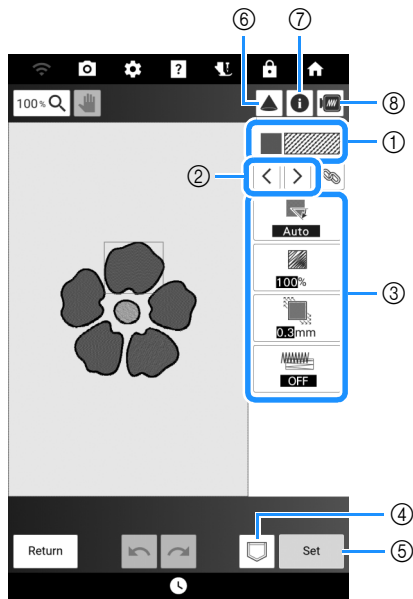

■ Region Settings







- ① Shows/Changes the stitch type and color for the selected region.
- ② Select the region to be changed.
- ③ Shows/Changes the stitch settings for the selected region.
- ④ Save the pattern drawing data and embroidery data.
- ⑤ Proceed to embroidery edit screen.
- ⑥ Use the projector to project the pattern. (page 154)
- ⑦ See detailed information about the pattern.
- ⑧ Preview the pattern.

□ Region Stitch Settings







Fill stitch pattern

 [Direction]	Specifies the embroidering direction. Select [Manual] to change to the desired direction of fill stitch.
 [Density]	Specifies the stitch density of fill stitch.
 [Pull compensation]	Specifies to correct the shrinkage of the pattern by slightly shortening or lengthening the stitching. Change the setting after you test embroider the pattern and can check the shrinkage.
 [Under sewing]	Select if you need or do not need the under sewing for the stabilized fabric.

Stippling pattern

 [Run Pitch]	Specifies the length of a stitch of the stippling stitch.
 [Spacing]	Specifies the spacing between the stitches when embroidering the stippling stitch.
 [Distance]	Specifies the offset from the pattern outline.
 [Stitch]	Specifies the stitch type (Single/Triple stitch).

Decorative fill patterns

 [Size]	Increases/reduces the size of the pattern.
 [Direction]	Specifies the rotation angle of the pattern.
 [Outline]	Select whether (turned on) or not (turned off) the outline is also converted to embroidery data. If turned on, the number of thread jumps can be reduced.
 [Random shift]	Randomly varies the line. If a setting of 1 or more is specified for [Random shift], a [Type] setting for the [Random shift] can be selected.
 [Position Offset]	Specifies the reference point for the pattern.
 [Thickness]	Sets repeated or single stitching of the pattern.

Specifying Global Stitch Settings

The same stitch settings can be changed at the same time for multiple patterns of the same type.

- 1 Use **<** **>** to select the stitch whose settings are to be changed, and then touch .

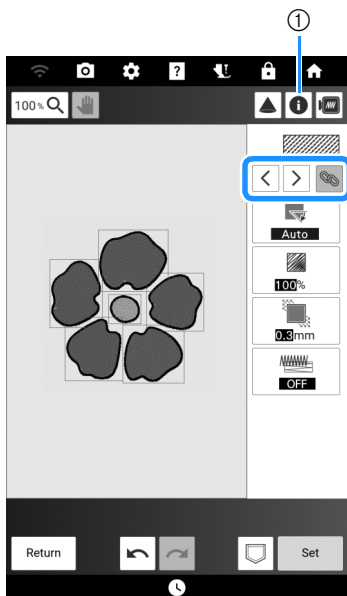

- ① Touch  to check various information such as the thread colors.
→ The same stitch type areas will be selected at the same time.

- 2 Change the settings and convert work into embroidery pattern. (page 238)

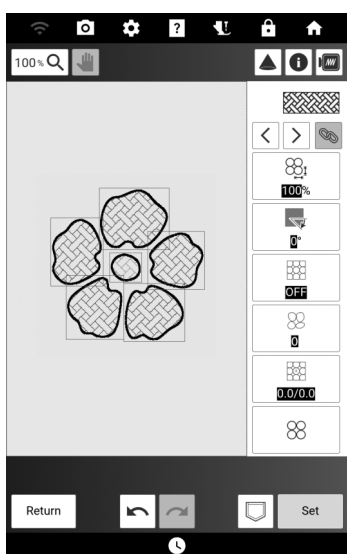

Create the Pattern Using Scanned Images or Image Data Files

In addition to using built-in shapes and drawing tools, you can create patterns using scanned images of fabric, line drawings, illustrations, and data files of images.

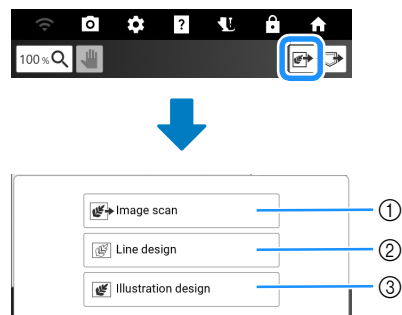

- ① Touch this key to use the image as a background image. (page 243, page 244)
- ② Touch this key to convert a line drawing to embroidery data. (page 245)
- ③ Touch this key to convert an illustration to embroidery data. (page 247)

Using the Scanning Frame

- 1 Prepare the desired drawing/illustration.

IMPORTANT

- If, during scanning, the embroidery foot comes into contact with the material to be scanned (illustration, etc.), the material to be scanned or embroidery foot may be damaged. Do not scan materials that may come into contact with the embroidery foot, such as thick materials or materials with wrinkles or creases.

Memo

- Only one sheet of paper can be placed in the scanning frame per scan.

2 Place the paper to be scanned in the scanning frame, and then secure the paper in place with the magnets.

- * Place the magnets at six locations around the paper to secure it, making sure that the line drawing is not covered.

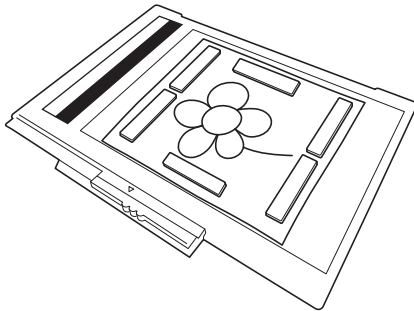

Note

- When placing the paper in the scanning frame, make sure that the white balance area is not hidden; otherwise, the drawing cannot be scanned correctly. At the same time, be sure to place the scan image within the scan area. The image out of the scan area will not be scanned.

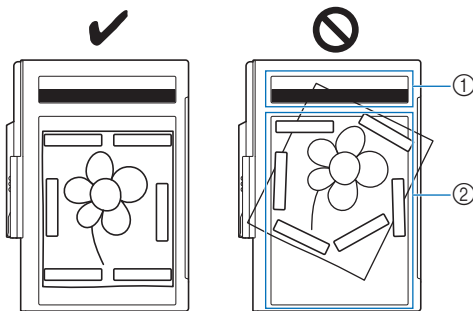

- ① White balance area
- ② Scan area

- Make sure that the white balance area or the scan area is not dirty or scratched; otherwise, the image cannot be scanned correctly.
- Be sure to use the magnets which are included with the scanning frame.
- Be sure to place the magnets so that they secure the paper firmly. If the paper is placed unevenly, the image cannot be scanned correctly.
- If the scanning frame is dirty, gently wipe it with a soft cloth that has been soaked in lukewarm water then firmly wrung.

3 Attach the embroidery unit to the machine, and then turn on the machine.

- * Refer to “Attaching the Embroidery Unit” on page 126.

Memo

- Unthread the machine to avoid having the thread slipping out of the needle or getting caught on the embroidery frame.

4 Press  (Presser foot lifter button) to raise the embroidery foot, and then press

 (Needle position button) to raise the needle.

- * The embroidery foot is not raised high enough when raised with the presser foot lever.

IMPORTANT

- Make sure that embroidery foot and needle are fully raised. If scanning is started with the embroidery foot and needle lowered, the scanning frame may hit the machine, causing damage.

5 After attaching the scanning frame to the embroidery unit, swing the frame-securing lever toward you to secure the scanning frame.

- * Refer to “Attaching the Embroidery Frame” on page 131.

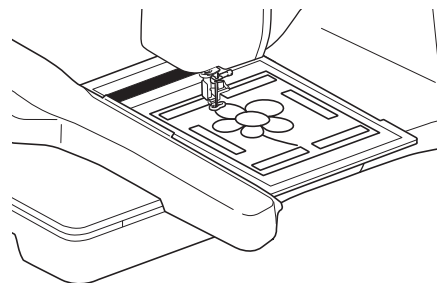

Note

- Be sure not to attach any embroidery foot other than the embroidery foot “W”, otherwise the embroidery foot will be scanned.

■ Scanning with an Embroidery Frame

Drawings and illustrations can also be scanned using an embroidery frame. Place the paper to be scanned on the fabric, and then secure it with tape.

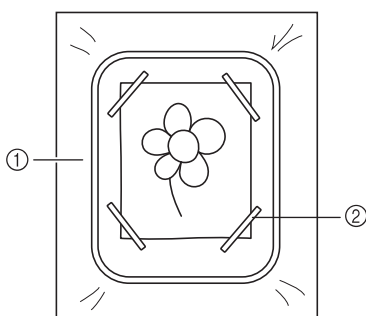

- ① Fabric
- ② Tape

Scanning the Background Image

Create patterns by scanning fabric or an illustration, importing it into the machine, then displaying it as a background image.

1 Touch .



2 Touch [Image scan].

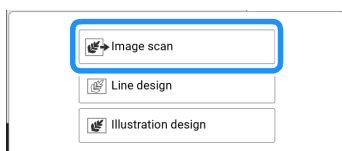

3 Using the magnets, affix a picture to the scanning frame and attach the frame to the machine. (page 241)
 When scanning the fabric, attach the embroidery frame to the machine. (page 131)

4 Touch [Scan].

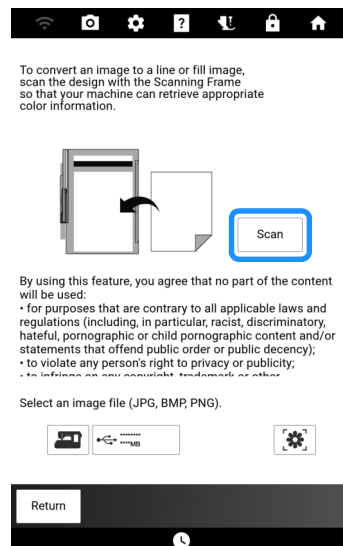

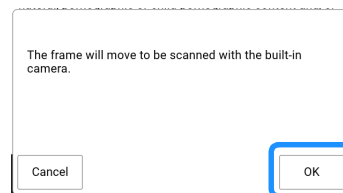

5 When the following message appears, touch [OK].





→ Scanning begins. When scanning is finished, scanned image is displayed transparently in the pattern drawing area.

6 Using the included dual purpose stylus, touch , and then draw lines to trace the image.

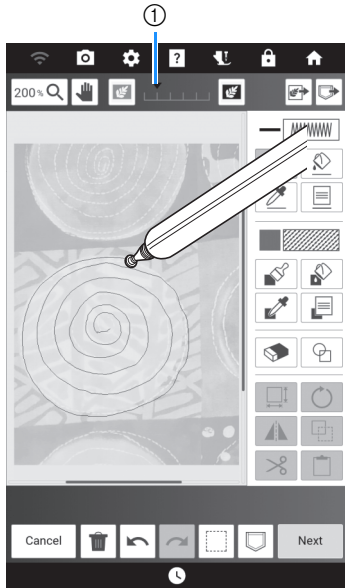
- * Touch  to magnify the pattern and use  to move the canvas.
- * For details on drawing lines, refer to “Drawing Lines” on page 232.



- ① Touch  or  to adjust the transparency of the background.

7 After editing the pattern, touch [Next] to specify the settings for pattern.

- * For details on editing patterns, refer to “Key Functions (My Design Center)” on page 230.

8 Touch [Set] to display the embroidery edit screen.

- * Refer to “Specifying Individual Stitch Settings” on page 238.

Importing the Background Image

Create patterns by importing image data into the machine, then displaying it as a background image.

1 Touch .



2 Touch [Image scan].

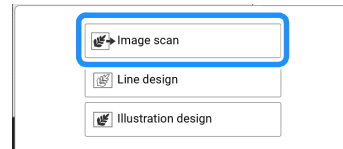

3 Select the device you saved the data to.

- * If two USB media are connected to the machine, check the USB media names that are displayed, and then touch the name of the USB media that you wish to use.

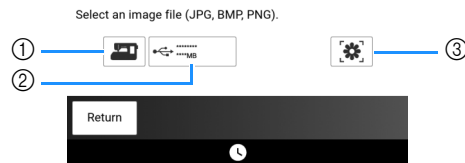

- ① The most recently scanned image is automatically stored in the machine’s memory. Touch this key to import the scanned image.
- ② Touch to import the data file saved on a USB media. Save data as a .jpg, .bmp, or .png file type, on a USB media. For details on files that can be imported, refer to “Specifications” on page 271.
- ③ Touch to transfer an image that was saved on the smart device then sent to the machine. (page 226)

4 Select the data, and then touch [Set].

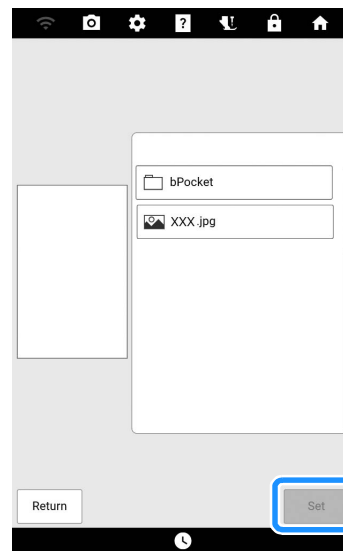

→ The selected image is displayed transparently in the pattern drawing area.

5 Create an embroidery pattern. Refer to step 6 of “Scanning the Background Image” on page 243.

Create a Pattern with Line Conversion

Custom patterns can be created from drawings. You can create patterns by scanning your drawings or importing an image data file.

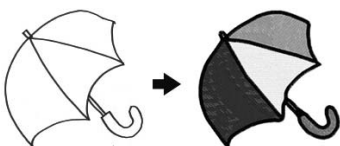

Recommended line drawings for Line Conversion

- Line drawings must be drawn clearly using lines with approximately 1 mm thickness.
- Line drawings should be drawn in a strong contrast.
- If the lines are too short or gathered too densely, they will not be converted correctly.

Memo

- For details on creating patterns using color illustrations, refer to “Create a Pattern with Illustration Conversion” on page 247.

1 Touch .



2 Touch [Line design].

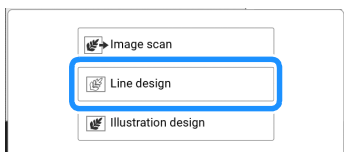

Memo

- When converting a scanned/imported background image to be displayed on the screen, skip step 3 and proceed to step 4.

3 When scanning using the scanning frame or the embroidery frame, touch [Scan]. When importing an image data file, select the device you saved the data to.

- * If two USB media are connected to the machine, check the USB media names that are displayed, and then touch the name of the USB media that you wish to use.

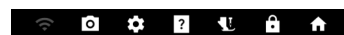

To convert an image to a line or fill image, scan the design with the Scanning Frame so that your machine can retrieve appropriate color information.

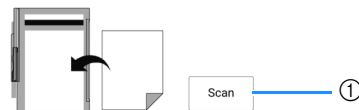

By using this feature, you agree that no part of the content will be used:
 • for purposes that are contrary to all applicable laws and regulations (including, in particular, racist, discriminatory, hateful, pornographic or child pornographic content and/or statements that offend public order or public decency);
 • to violate any person's right to privacy or publicity;
 • to infringe on any copyright, trademark or other

Select an image file (JPG, BMP, PNG).



- ① When this key is touched, the message to start scanning appears. Touch [OK] to start scanning.
- ② The most recently scanned image is automatically stored in the machine's memory. Touch this key to import the scanned image.
- ③ Touch to import the data file saved on a USB media. Save data as a .jpg, .bmp, or .png file type, on a USB media. For details on files that can be imported, refer to “Specifications” on page 271.
- ④ Touch to transfer an image that was saved on the smart device then sent to the machine. (page 226)

4 Move to frame the image for the pattern. And then touch [OK].

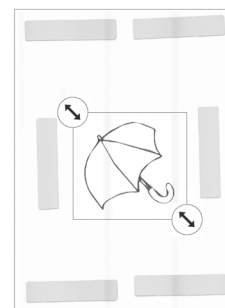
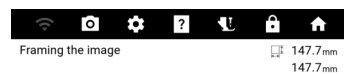

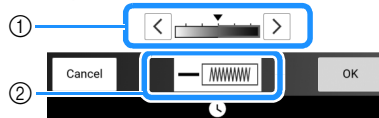

Gray-Scale Detection level

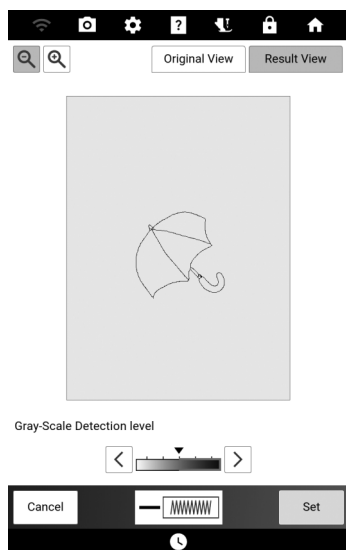

- ① Adjust the image detection level.
- ② Changes the line color and stitch type. (page 233)

5 Confirm the converted image and then touch [Set].





- * Adjust the [Gray-Scale Detection level], the line color and stitch type, if necessary. After changes to the settings have been applied, [Set] changes to [Retry]. Touch [Retry] to check that the image is as desired.
- * To enlarge the image, touch .
- * To display the image before being converted, touch [Original View].

6 If necessary, edit the design.

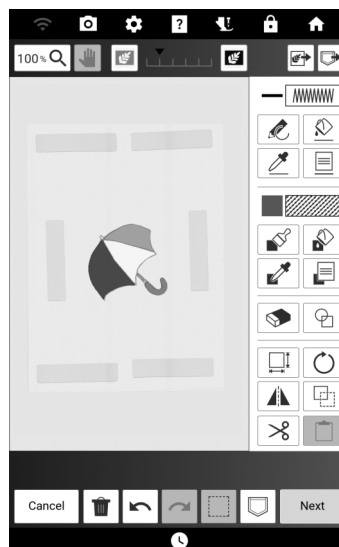
- * Refer to “Key Functions (My Design Center)” on page 230.



- * After the image is converted to stitching, it appears as a background in the pattern drawing screen. Touch  or  to adjust the transparency of the background.

Memo

- Small dots or unwanted lines can be erased with the erase key. (page 235)
- Line drawings are converted without recognizing the thickness of lines. If you want to change the thickness of lines, specify in the settings screen. Refer to “Stitch Settings Screen” on page 238.

Create a Pattern with Illustration Conversion

Custom patterns can be created from color illustrations. You can create patterns by scanning an illustration or importing an image data file.

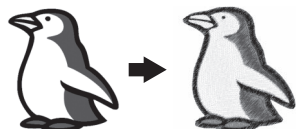

Recommended illustrations for Illustration Conversion

- Illustrations that are clearly drawn, with no gradation, fading or blurriness.
- Illustrations that are at least a 5 mm square
- Illustrations that are extremely simple images

1 Touch .



2 Touch [Illustration design].

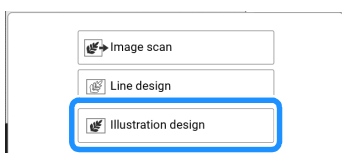

Memo

- When converting a scanned/imported background image to be displayed on the screen, skip step 3 and proceed to step 4.

3 When scanning the scanning frame or the embroidery frame, touch [Scan]. When importing an image data file, select the device you saved the data to. For this example, import the image data file.

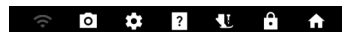

To convert an image to a line or fill image, scan the design with the Scanning Frame so that your machine can retrieve appropriate color information.

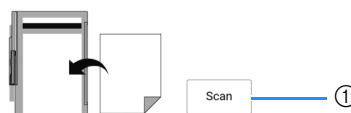

By using this feature, you agree that no part of the content will be used:
 • for purposes that are contrary to all applicable laws and regulations (including, in particular, racist, discriminatory, hateful, pornographic or child pornographic content and/or statements that offend public order or public decency);
 • to violate any person's right to privacy or publicity;
 • to infringe on any copyright, trademark or other

Select an image file (.JPG, BMP, PNG).





- ① When this key is touched, the message to start scanning appears. Touch [OK] to start scanning.
- ② The most recently scanned image is automatically stored in the machine's memory. Touch this key to import the scanned image.
- ③ Touch to import the data file saved on a USB media. Save data as a .jpg, .bmp, or .png file type, on a USB media. For details on files that can be imported, refer to "Specifications" on page 271.
- ④ Touch to transfer an image that was saved on the smart device then sent to the machine. (page 226)

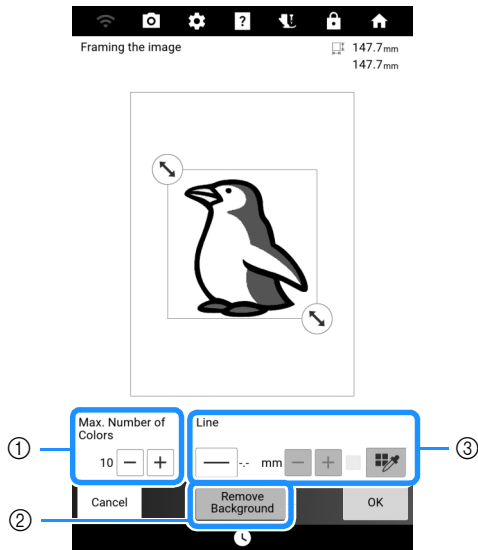

4 Move to frame the image for the pattern. And then touch [OK].

* Change the settings to adjust the image so it can easily be converted to the desired pattern.



- ① The number of colors in an image will be reduced less than the number specified here.
- ② Select whether or not the background will be removed.
- ③ Touch  to convert the outline of the image to lines. (If this is not selected, the outline of the image will be converted to regions.) Line thickness can be specified using .



Touch  to select the outline color. Select by touching the color, or moving  icon using

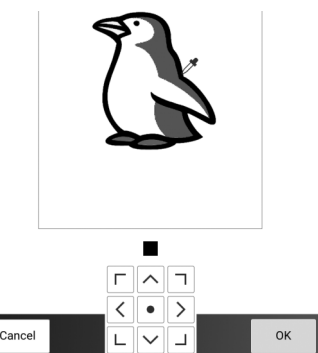



5 Confirm the converted image and then touch [Set].

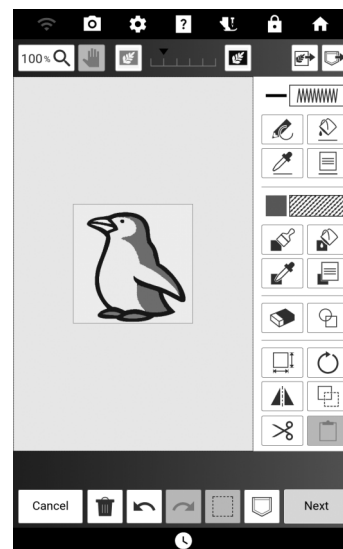

- * Adjust the image as necessary as in step 4. After changes to the settings have been applied, [Set] changes to [Retry]. Touch [Retry] to check that the image is as desired.
- * To enlarge the image, touch .
- * To display the image before being converted, touch [Original View].

6 If necessary, edit the design.



- * After the image is converted to stitching, it appears as a background in the pattern drawing screen. Touch  or  to adjust the transparency of the background.

Various Embroidering with My Design Center

Decorative Stitching Around a Pattern



■ Saving the Outline of the Pattern

- 1 Touch [Embroidery] in the home page screen and select a pattern.
- 2 Touch [Edit] then .

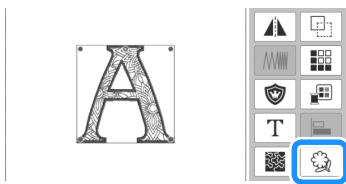

- 3 Specify the settings and touch .

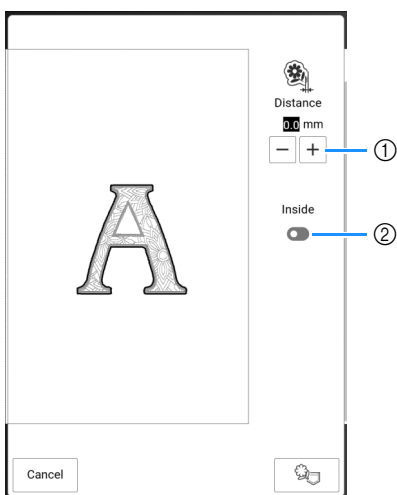

- ① Specify the distance from the outline of the pattern to the pattern.
- ② When set to on, lines inside the pattern are also extracted.

- 4 Touch [OK].



→ The pattern outline is saved as a stamp shape in My Design Center.

■ Editing Patterns Using Saved Outline

- 1 Touch [Add].

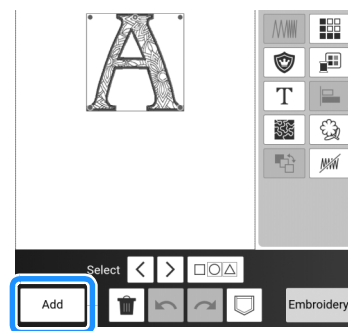

- 2 Touch [My Design Center].

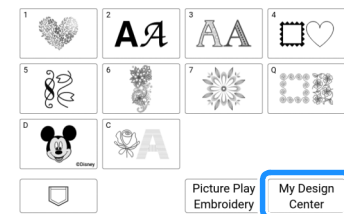

- 3 Touch  then .

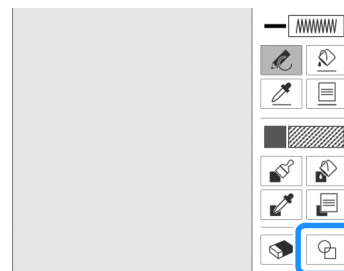

- 4 Select the saved outline.



5 Touch  and select a stamp shape.

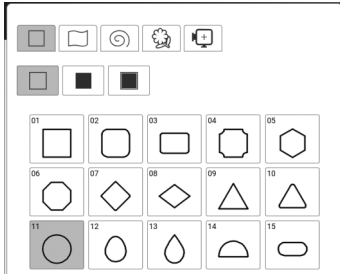

6 Touch  and change the size.

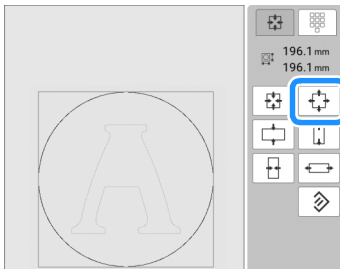

7 Touch  and select the stitch type and color of the circle.

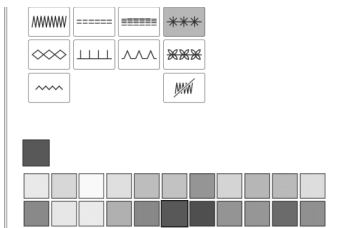

8 Touch  and touch the circle.

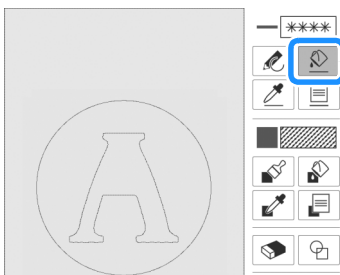

9 Touch  and select the fill stitch type and color of the decorative fill pattern.

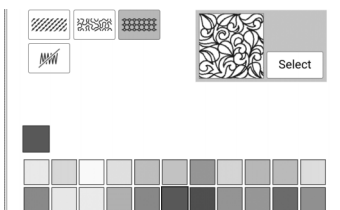

10 Touch , and then touch the area you want to add the decorative fill pattern.



11 Touch [Next].

12 Specify the stitch settings, and then touch [Set].

* For details, refer to "Specifying Individual Stitch Settings" on page 238.

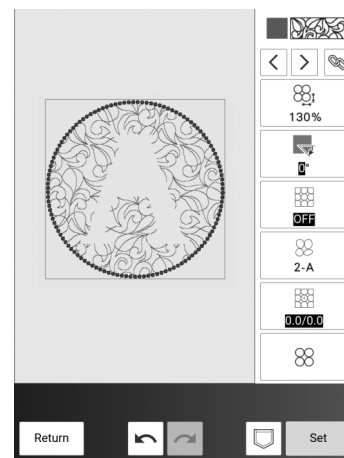

→ The embroidery edit screen appears after touching [OK].

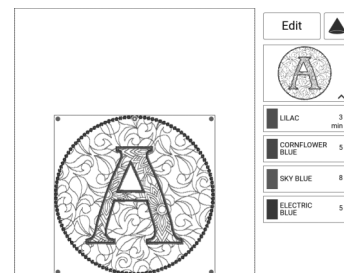

When Embroidering with Batting Sandwiched Between Two Layers of Fabric

After embroidering the quilt top, use the scanning feature to align the patterns.

Memo

- For best results, reduce the embroidery speed.
- For best results, hoop the stabilizer and quilt top and embroider the design prior to adding the batting and backing.

- 1 Select a pattern. Touch  and register the pattern outline as a stamp. (page 249)

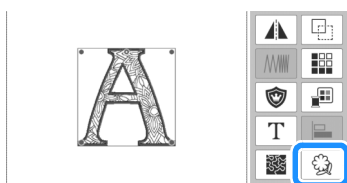

- 2 Touch [Embroidery] and then embroider the pattern.

- 3 Remove the embroidered quilt top from the embroidery frame. Tear off the stabilizer. Layer with batting and backing, then secure the three layers together in the embroidery frame.

- 4 Attach the embroidery frame.

- 5 Touch  then [OK]. Touch [My Design Center] in the home page screen.

- 6 Touch  then [Image scan]. Touch [Scan] to scan the embroidered fabric. (page 244)

- 7 Touch  then .



- 8 Select the saved outline in step 1.

- 9 Touch  and then arrange the stamp over the scanned pattern.

* To rotate the stamp, touch .

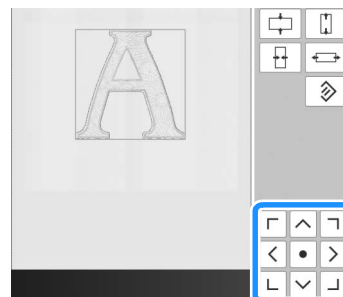

- 10 Edit the pattern and then touch [Next].

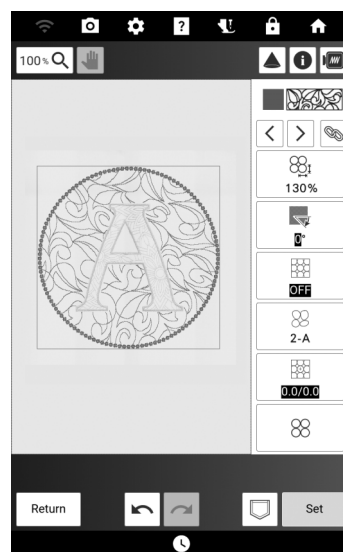

- 11 Specify the stitch settings, and then touch [Set].

* For details, refer to "Specifying Individual Stitch Settings" on page 238.

→ The embroidery edit screen appears after touching [OK].

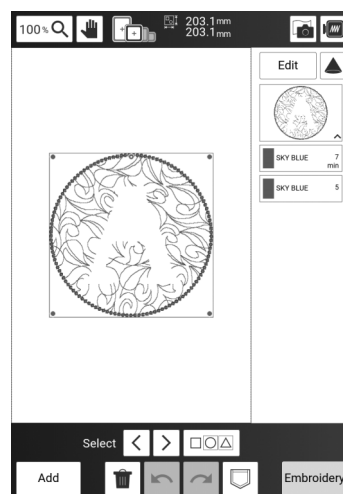





Decorative Stitching Around a Couching Patterns

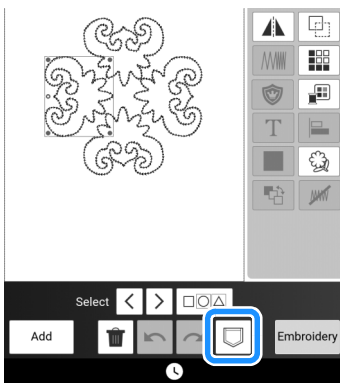

■ Saving the Outline of the Couching Pattern

- 1 Touch [Embroidery] in the home page screen and edit the couching patterns.
- 2 Touch  and save the combined couching pattern on the machine's memory for later use.



- 3 Touch  to select all patterns and then touch .
- 4 Specify the setting and touch .

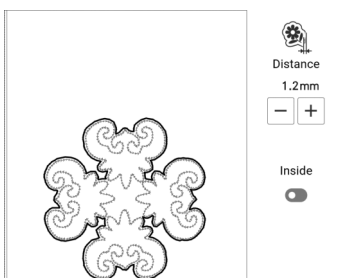

- 5 Touch  and then [OK].

■ Embroidering the Decorative Patterns

- 1 Touch [My Design Center] in the home page screen.
- 2 Touch  then select the saved outline in step 2 of "Saving the Outline of the Couching Pattern" on page 252.

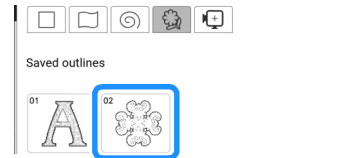

- 3 Touch  and select the square shape. And then touch  to change the size.

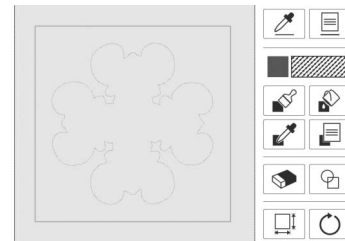

- 4 Touch  and select the stitch type and color.

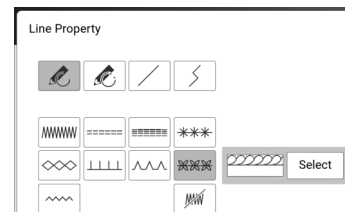

- 5 Touch  and touch the square.

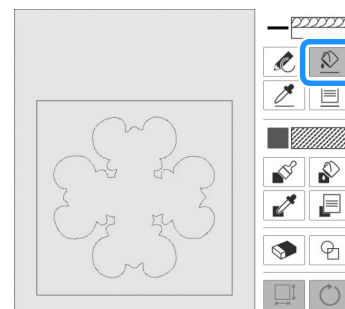

- 6** Touch  and select the pattern and color of the decorative fill pattern.

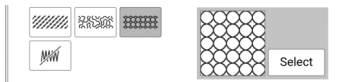

- 7** Touch , and then touch the area you want to add the decorative fill pattern.

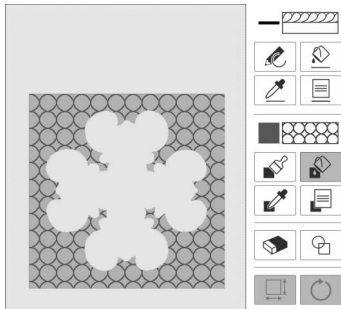

- 8** Touch [Next].

- 9** Specify the stitch settings, and then touch [Set].

* For details, refer to "Specifying Individual Stitch Settings" on page 238.

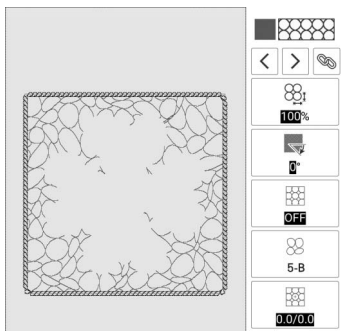

- 10** Touch [Embroidery] and then embroider the pattern.

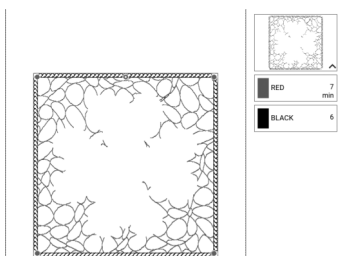

- 11** Touch  and then [OK].

■ Embroidering the Couching Patterns

- 1** Touch [Embroidery] in the home page screen and touch .

- 2** Retrieve the saved couching pattern.

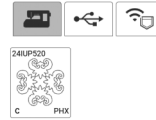

- 3** Prepare the machine for couching. Attach embroidery couching foot "Y", thread it with yarn, and then thread the machine with the upper thread.

* For details, refer to "Embroidering Couching Patterns" on page 191.

Chapter 7 Maintenance and Troubleshooting

Care and Maintenance

⚠ CAUTION

- Be sure to unplug the machine before cleaning it. Otherwise, injury may result.

Restrictions on Oiling

In order to prevent damaging this machine, it must not be oiled by the user. This machine was manufactured with the necessary amount of oil applied to ensure correct operation, making periodic oiling unnecessary.

If problems occur, such as difficulty turning the handwheel or an unusual noise, immediately stop using the machine, and contact your authorized Brother dealer or the nearest Brother authorized service center.

Precautions on Storing the Machine

Do not store the machine in any of the locations described below, otherwise damage to the machine may result, for example, rust caused by condensation.

- Exposed to extremely high temperatures
- Exposed to extremely low temperatures
- Exposed to extreme temperature changes
- Exposed to high humidity or steam
- Near a flame, heater or air conditioner
- Outdoors or exposed to direct sunlight
- Exposed to extremely dusty or oily environments

💡 Note

- In order to extend the life of this machine, periodically turn it on and use it. Storing this machine for an extended period of time without using it may reduce its efficiency.

Cleaning

■ Cleaning the LCD Screen

If the surface of the LCD is dirty, lightly wipe it with a soft dry cloth.

📝 Memo

- Occasionally, condensation may form on the LCD screen or it may become fogged up; however, this is not a malfunction. After a while, the cloudiness will disappear.

■ Cleaning the Machine Casing

When wiping dirt off the machine, firmly wring a soft cloth soaked in (lukewarm) water. After cleaning the machine, dry it with a soft, dry cloth.

■ Cleaning the Race

- 1 Press  (Needle position button) to raise the needle.
- 2 Turn the main power to OFF, and then unplug the machine.
- 3 Remove the needle and the presser foot. (page 36, page 48)
- 4 Remove the flat bed attachment or the embroidery unit if either is attached.
- 5 Slide the needle plate lever toward you.

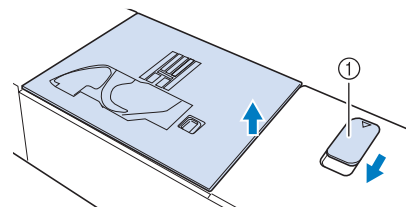

- ① Slide toward you.
→ The needle plate opens.

6 Slide out the needle plate with your right hand to remove it.

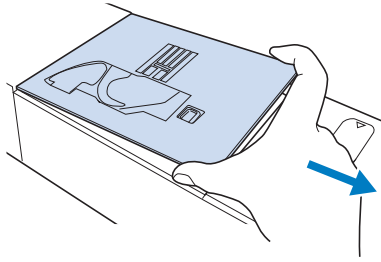

7 Grasp the bobbin case, and then gently lift out.

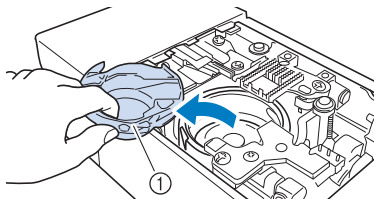

① Bobbin case

8 Use the cleaning brush or a vacuum cleaner to remove any lint and dust from the race and bobbin thread sensor and the surrounding area.

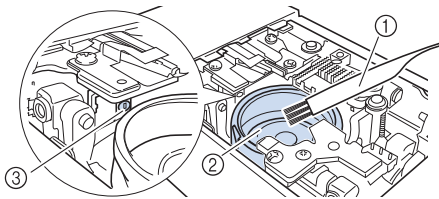

① Cleaning brush
② Race
③ Bobbin thread sensor

IMPORTANT

- Do not apply oil to the bobbin case.

Memo

- If lint or dust collects on the bobbin thread sensor, the sensor may not operate correctly.

9 Insert the bobbin case so that the ▲ mark on the bobbin case aligns with the ● mark on the machine.

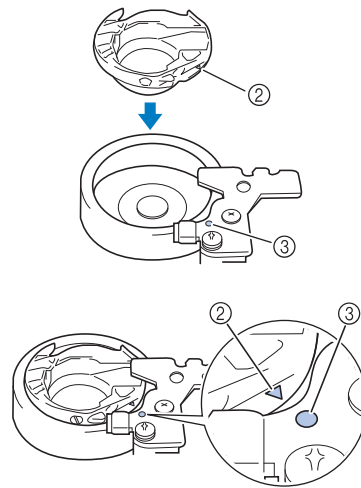
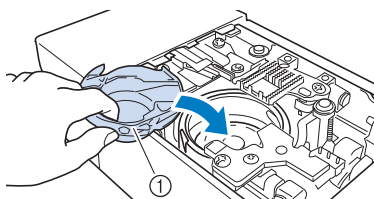

① Bobbin case
② “▲” mark on the bobbin case
③ “●” mark on the machine

- * Make sure that the indicated points are aligned before installing the bobbin case.

CAUTION

- Never use a bobbin case that is scratched or has a burr on it. Otherwise the upper thread may become tangled, and the needle may break and cause injury. For a new bobbin case, contact your nearest Brother authorized service center.
- Make sure that you fit the bobbin case properly, otherwise the needle may break and cause injury.

10 Insert the tabs on the needle plate into the notches in the machine.

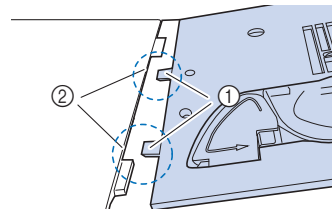

① Tabs
② Notches

11 Press down on the right side of the needle plate to secure it.

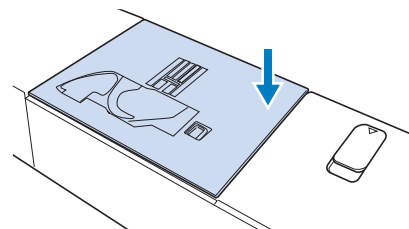

■ Cleaning the Cutter in the Bobbin Case Area

If dust or lint accumulate on the cutter, it will be difficult to cut the thread when  (Thread cutter button) is pressed or the automatic thread cutting function is used. Clean the cutter when the thread is not easily cut.

- 1 Follow steps 1 through 7 of “Cleaning the Race” on page 255 to remove the needle plate and bobbin case.
- 2 Use the cleaning brush or a vacuum cleaner to remove any lint and dust from the cutter in the bobbin case area.

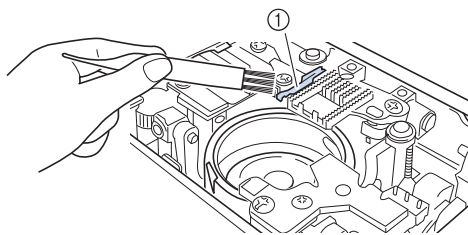

① Cutter

⚠ CAUTION

- Do not touch the cutter, otherwise injuries may result.

3 Attach the needle plate.

Needle Calibration for Camera/Projector

Setting the camera needle position is essential when you use camera or projector function. It is not necessary to perform this operation each time, but we recommend performing it when the needle is changed. Use the white calibration stickers (solid) included with the machine.

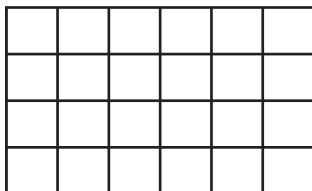

- 1 Touch  to display [Needle Calibration for Camera/Projector] of the settings screen.
- 2 Touch .

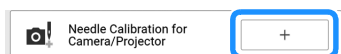

3 Follow the on-screen instructions to complete the procedure.

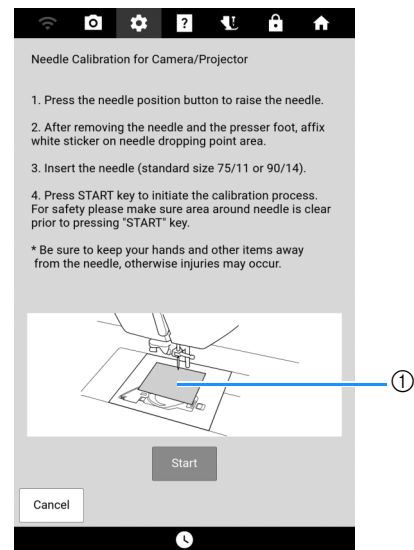

① White calibration sticker

Note

- Use a new sticker. The camera needle position cannot be set correctly if there is a hole in sticker or if it is dirty.

→ The operation is finished when [OK] appears.



Note

- If [NG] appears, affix a new white sticker, and then touch [Retry]. If multiple attempts to set the position are not successful, contact your nearest authorized Brother dealer.

4 Touch [OK] to memorize the calibration data.

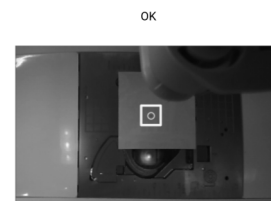

Press OK key to memorize the needle drop position.



5 Remove the sticker.

Before Lending or Disposing of the Product

Please be sure to reset the settings of your machine to delete the following data.

- all saved data
- customized settings
- network information

- 1 Touch , and then touch [Reset] beside [Reset to Default].
- 2 Touch [Reset].

Note

- Do not turn the main power to OFF while the [Deleting...] screen is displayed.

Confirming the Machine Number/Serial Number

Confirming the Machine Number

There may be circumstances where the machine number is required.

- 1 Touch .
- 2 Display the settings screen below.

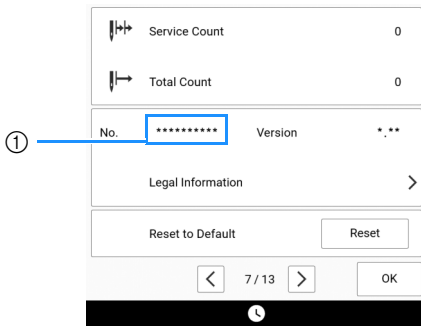

① Machine number (internal machine number)

Confirming the Serial Number

Confirm the rating plate on the back of the machine.



① Serial number

Updating Your Machine's Software

You can update your machine's software using one of the two procedures.

Update Procedure Using USB Media

When an update program is available on <https://s.brother/cpdae/>, please download the files following the instructions on the website and steps below.

Note

- Check that no data other than the update file is saved on the USB media being used before starting to update.
- Some USB media may not be usable with this machine. For compatible USB media, refer to "Specifications" on page 271.

- 1 Insert the USB media into the USB port. The media device should only contain the update file.

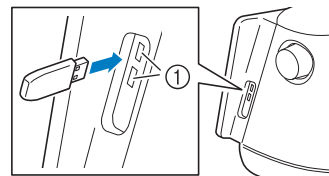

① USB ports

- 2 While pressing , turn the main power to ON.

- 3 Touch .

- * If two USB media are connected to the machine, check the USB media names that are displayed, and then touch the name of the USB media that you wish to use.

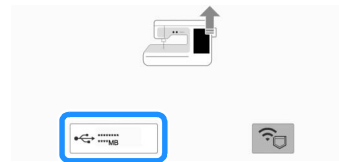

- 4 Touch [Load] to update the machine.

IMPORTANT

- Do not turn off the machine during the update. When updating is finished, the completion message appears.

5 Remove the USB media, and turn the machine off and on again.

IMPORTANT

- It will take a while to start up the machine. The screen may get dark during the start up, do not turn off the machine and wait until the opening screen appears. Depending on the machine settings, a different screen may appear instead of the opening screen.

Update Procedure Using Wireless LAN Connection

If the machine is connected to a wireless network with a strong, reliable connection, update files can be downloaded directly to the machine using this network.

Memo

- The machine periodically checks if there is a new update file on the server. When there is a new update file, the wireless LAN key is displayed as .



1 Connect the machine to your wireless network.

* Refer to "Wireless Network Connection Functions" on page 31.

2 Touch  to display [Download the update program] of the settings screen.

3 Touch [Start].

* The machine starts to download the update file, if there is a new update file on server.

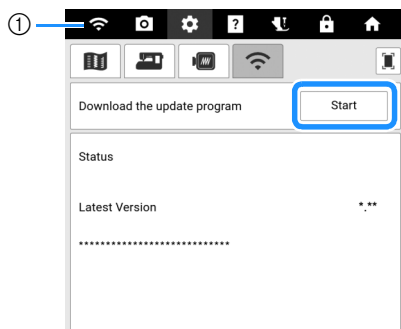

① When the wireless LAN key appears as , touching [Start] causes the machine to check if there is a new update file. If there is a new file, downloading begins.

Note

- Do not turn off the machine during the download.
- Touch [Pause] to pause the download. To restart, touch [Resume].

4 When downloading is finished, turn off the machine, then hold down  (Automatic threading button) while turning on the machine.

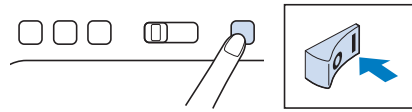

5 Touch .

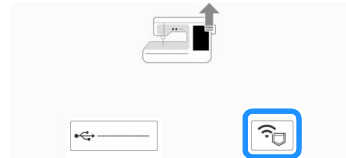

6 Touch [Load] to update the machine.

IMPORTANT

- Do not turn off the machine during the update. When updating is finished, the completion message appears.

7 Turn the machine off and on again.

IMPORTANT

- It will take a while to start up the machine. The screen may get dark during the start up, do not turn off the machine and wait until the opening screen appears. Depending on the machine settings, a different screen may appear instead of the opening screen.

Memo

- If there are changes or additions to functions, manuals available on the machine may be updated.

Troubleshooting

If the machine stops operating correctly, check the following possible problems before requesting service.

You can solve most problems by yourself. If you need additional help, the Brother support website offers the latest FAQs and troubleshooting tips. Visit us at <https://s.brother/cpdae/>.

If the problem persists, contact your authorized Brother dealer or the nearest Brother authorized service center.

Memo

- The instructional videos are available online and can be viewed on any mobile device or computer.



<https://s.brother/cvdae/>

- You can also access them using the QR code that appears in the screen. (page 29)

■ Frequent Troubleshooting Topics

Detailed causes and remedies for common troubleshooting topics are described below. Be sure to refer to this before contacting your authorized Brother dealer.

- “Upper Thread Is Too Tight” on page 260
- “Tangled Thread on Wrong Side of Fabric” on page 261
- “Incorrect Thread Tension” on page 261
- “Fabric Is Caught in the Machine and Cannot be Removed” on page 262
- “If the Thread Becomes Tangled Under the Bobbin Winder Seat” on page 263

Upper Thread Is Too Tight

■ Symptom

- The upper thread appears as a single continuous line.
- The bobbin thread is visible from the right side of the fabric. (Refer to the illustration below.)
- The upper thread has tightened up, and comes out when pulled.
- The upper thread has tightened up, and wrinkles appear in the fabric.
- The upper thread tension is tight, and the results do not change even after the thread tension is adjusted.

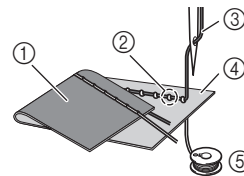

- ① Wrong side of fabric
- ② Bobbin thread visible from right side of fabric
- ③ Upper thread
- ④ Right side of fabric
- ⑤ Bobbin thread

■ Cause

Incorrect bobbin threading

If the bobbin thread is incorrectly threaded, instead of the appropriate tension being applied to the bobbin thread, it is pulled through the fabric when the upper thread is pulled up. For this reason, the thread is visible from the right side of the fabric.

■ Remedy

Correctly install the bobbin thread. (page 40)

Tangled Thread on Wrong Side of Fabric

■ Symptom

- The thread becomes tangled on the wrong side of the fabric.

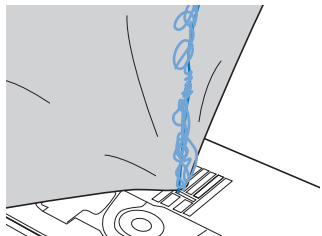

- After starting sewing, a rattling noise is made and sewing cannot continue.
- Looking under the fabric, there is tangled thread in the bobbin case.

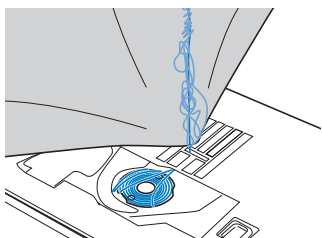

■ Cause

Incorrect upper threading

If the upper thread is incorrectly threaded, the upper thread passed through the fabric cannot be firmly pulled up and the upper thread becomes tangled in the bobbin case, causing a rattling noise.

■ Remedy

Remove the tangled thread, and then correct the upper threading.

1 Remove the tangled thread. If it cannot be removed, cut the thread with scissors.

* Refer to "Cleaning the Race" on page 255.

2 Remove the upper thread from the machine.

3 Correct the upper threading by following the instructions of "Upper Threading" on page 42.

* If the bobbin was removed from the bobbin case, refer to "Setting the Bobbin" on page 40 to correctly install the bobbin.

Incorrect Thread Tension

■ Symptoms

- Symptom 1: The bobbin thread is visible from the right side of the fabric.
- Symptom 2: The upper thread appears as a straight line on the right side of the fabric.
- Symptom 3: The upper thread is visible from the wrong side of the fabric.
- Symptom 4: The bobbin thread appears as a straight line on the wrong side of the fabric.
- Symptom 5: The stitching on the wrong side of the fabric is loose or has slack.

□ Symptom 1

□ Symptom 3

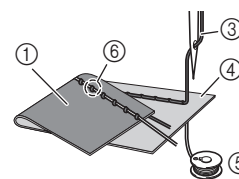
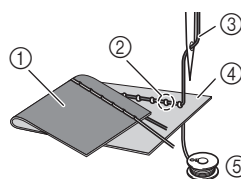

- ① Wrong side of fabric
- ② Bobbin thread visible on right side of fabric
- ③ Upper thread
- ④ Right side of fabric
- ⑤ Bobbin thread
- ⑥ Upper thread visible from wrong side of fabric

■ Cause/Remedy

□ Cause 1

The machine is not correctly threaded.

<With symptoms 1 and 2 described above>

The bobbin threading is incorrect.

Return the upper thread tension to the standard setting, and then refer to "Setting the Bobbin" on page 40 to correct bobbin threading.

<With symptoms 3 through 5 described above>

The upper threading is incorrect.

Return the upper thread tension to the standard setting, and then refer to "Upper Threading" on page 42 to correct the upper threading.

□ **Cause 2**

A needle and thread appropriate for the fabric are not being used.

The machine needle that should be used depends on the type of fabric sewn and the thread thickness.

If a needle and thread appropriate for the fabric are not being used, the thread tension will not be adjusted correctly, causing wrinkles in the fabric or skipped stitches.

- * Refer to “Fabric/Thread/Needle Combinations” on page 34 to check that a needle and thread appropriate for the fabric are being used.

□ **Cause 3**

An appropriate upper tension is not selected.

Adjust the upper thread tension to select an appropriate thread tension.

The appropriate thread tension differs according to the type of fabric and thread being used.

- * Adjust the thread tension while test sewing on a piece of scrap fabric that is the same as that used in your project.

 **Note**

- If the upper threading and bobbin threading are incorrect, the thread tension cannot be adjusted correctly, even by adjusting the upper thread tension. Check the upper threading and bobbin threading first, and then adjust the thread tension.
- * When the bobbin thread is visible on the right side of the fabric, set the upper thread tension to a lower number. (Loosen the thread tension.)
- * When the upper thread is visible on the wrong side of the fabric, set the upper thread tension to a higher number. (Tighten the thread tension.)

Width	Length	L/R Shift	Tension
^	^	^	^
2.5 mm	2.5 mm	0.00 mm	4.0 ml
v	v	v	v

Fabric Is Caught in the Machine and Cannot be Removed

If the fabric is caught in the machine and cannot be removed, the thread may have become tangled under the needle plate. Follow the procedure described below to remove the fabric from the machine. If the operation could not be completed according to the procedure, instead of attempting to complete it forcefully, contact your authorized Brother dealer or the nearest Brother authorized service center.

■ Removing the Fabric from the Machine

- 1 Immediately stop the machine.**
- 2 Turn the main power to OFF, and then unplug the machine.**

- 3 Remove the needle.**

If the needle is lowered into the fabric, turn the handwheel away from you (clockwise) to raise the needle out of the fabric, and then remove the needle.

- * Refer to “Changing the Needle” on page 36.

- 4 Remove the presser foot.**

If the thread is entangled on the presser foot, remove the entangled thread, and then raise the presser foot lever to remove the presser foot. Otherwise, the presser foot may be damaged.

- * Refer to “Replacing the Presser Foot” on page 48.

- 5 Lift up the fabric and cut the threads below it.**

If the fabric can be removed, remove it. Continue with the following steps to clean the race.

- 6 Remove the needle plate and bobbin case.**

If threads remain in the bobbin case, remove them.

- * Refer to “Cleaning the Race” on page 255.

- 7 Remove any threads in the race and around the feed dogs.**

- * Refer to step **8** of “Cleaning the Race” on page 255.

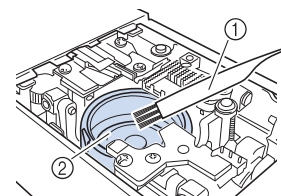

- ① Cleaning brush
- ② Race

8 Insert the bobbin case and then attach the needle plate.

- * Refer to steps 9 through 11 of “Cleaning the Race” on page 255.

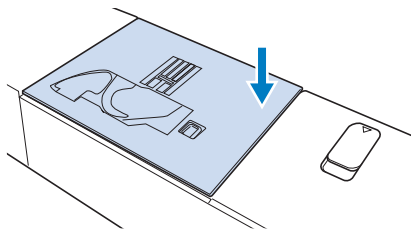

9 Check the condition of the needle, and then install it.

If the needle is in a poor condition, for example, if it is bent, be sure to install a new needle.

- * Refer to “Changing the Needle” on page 36.

■ Checking Machine Operations

If the needle plate has been removed, check machine operations to confirm that installation has been completed correctly.

1 Turn on the machine.

→ The needle moves to the left and right.

Note

- If an error occurs, the machine may be malfunctioning; therefore, contact your authorized Brother dealer or the nearest Brother authorized service center.

2 Select Straight stitch (Middle).

- * Refer to the “Stitch Chart” on page 273.

Note

- Do not yet install the presser foot and thread.

3 Slowly turn the handwheel toward you (counterclockwise), and look from all sides to check that the needle falls at the center of the hole in the needle plate.

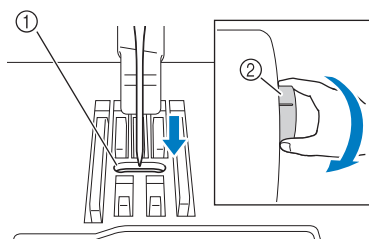

- ① Hole in the needle plate
- ② Handwheel

If the needle or feed dogs contact the needle plate, the machine may be malfunctioning; therefore, contact your authorized Brother dealer or the nearest Brother authorized service center.

4 Turn off the machine, and then install the bobbin and presser foot.

Never use a scratched or damaged presser foot. Otherwise, the needle may break, or sewing performance may suffer.

- * Refer to “Setting the Bobbin” on page 40 and “Changing the Presser Foot” on page 48.

5 Correctly thread the machine.

- * For details on the machine, refer to “Upper Threading” on page 42.

Note

- The thread may have become tangled as a result of incorrect upper threading. Make sure that the machine is correctly threaded.

6 Perform trial sewing with normal fabric.

Note

- Remember when sewing thin fabrics, select a center stitch that is shorter in length and use the straight stitch needle plate for straight sewing stitches. A lightweight paper stabilizer can also be placed on the underside of the fabric.

If the Thread Becomes Tangled Under the Bobbin Winder Seat

If the bobbin winding starts when the thread is not passed through the pretension disk correctly, the thread may become tangled beneath the bobbin winder seat.

Wind off the thread according to the following procedure.

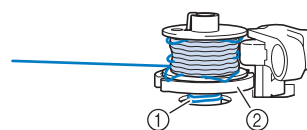

- ① Thread
- ② Bobbin winder seat

⚠ CAUTION

- Do not remove the bobbin winder seat even if the thread becomes tangled under the bobbin winder seat. The cutter in the bobbin winder seat may cause injury.

1 Touch [Stop] once to stop the bobbin winding.



- 2** Cut the thread with scissors near the pretension disk.

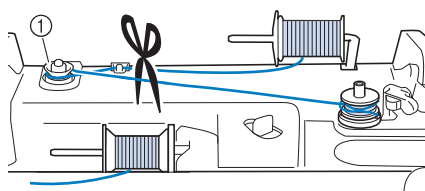

① Pretension disk

- 3** Push the bobbin winder switch to the right, and then remove the bobbin from the shaft and cut the thread leading to the bobbin in order to be able to completely remove the bobbin from shaft.

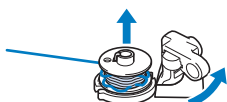

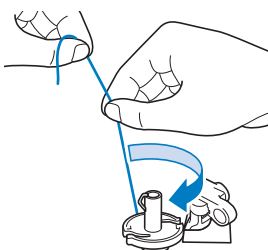

- 4** Hold the thread end with your left hand, and wind off the thread clockwise from under the bobbin winder seat with your right hand as shown below.





List of Symptoms

Check the following possible problems before requesting service. If the reference page is “*”, contact your authorized Brother dealer or the nearest Brother authorized service center.

Getting Ready

Symptom, Cause/solution	Reference
Cannot thread the needle.	
Needle is not in the correct position. • Press  (Needle position button) to raise the needle.	14
Needle is installed incorrectly.	36
Needle is turned, bent or the point is dull.	36
Upper threading is incorrect.	42
The needle threader hook is bent and does not pass through the eye of the needle.	*
The needle threader lever cannot be moved or returned to its original position.	*
A size 65/9 needle is being used. • The needle is incompatible with the needle threader. Manually pass the thread through the eye of the needle.	42
Cannot lower the presser foot with the presser foot lever.	
Presser foot was raised using  (Presser foot lifter button). • Press  (Presser foot lifter button) to lower the presser foot.	14
Bobbin thread does not wind neatly on the bobbin.	
The thread is not passed through the bobbin winding thread guide correctly.	37
Bobbin spins slowly.	37
The thread that was pulled out was not wound onto the bobbin correctly.	37
The empty bobbin was not set on the pin properly.	37
While winding the bobbin, the bobbin thread was wound below the bobbin winder seat.	
You have not wound the bobbin thread properly when you initially wound thread on the bobbin. Ensure that the bobbin thread was properly set in the guides.	37

Symptom, Cause/solution	Reference
The bobbin thread cannot be pulled up.	
Needle is turned, bent or the point is dull.	36
Bobbin is set incorrectly.	40
Machine does not operate	
All keys and buttons have been locked by  .	18
Nothing appears in the LCD.	
Main power switch is not turned on.	16
The plug of the power cord is not inserted into an electrical outlet.	16
The LCD screen does not look very clear.	
The brightness of the screen is not adjusted.	23
Nothing happens, even if the LCD display is touched.	
The screen has been locked. • Touch either of the following keys to unlock the screen.  	18
The LCD screen is fogged up.	
Condensation has formed on the LCD screen. • After a while, the cloudiness will disappear.	—
The dual purpose stylus cannot be operated.	
Clean the light-emitting part of the dual purpose stylus.	—
Replace the battery with a new one.	70
Embroidery unit does not operate.	
Embroidery unit is not attached correctly.	126
Embroidery frame was attached before the unit was initialized.	126
Pointer of the projector does not indicate the position correctly.	
With thick elastic fabric, the position will be misaligned only at raised parts in the fabric.	139
With fabric having a very uneven surface, the position is not correctly aligned. • The pointer indication should be used only as a reference.	—
Machine cannot connect to the wireless network.	
The date set is off by a few weeks from the actual date. • Touch the Time/Date key at the bottom of the screen and adjust to the current date.	—
You are connecting to 5 GHz network frequency band. • This machine only supports 2.4 GHz network frequency band.	—
The wireless network setting is not activated.	32

Symptom, Cause/solution	Reference
The security information (SSID/password (network key)/authentication method) is incorrect. • Reconfirm the SSID and security information and re-enter the correct information as necessary.	32
The wireless access point/router cannot be detected. • Make sure that the wireless access point/router is powered on. • Move your machine to an area where no items can obstruct the wireless network signal, such as metal doors or walls, or closer to the wireless access point/router. • Temporarily place your machine within about 1 m (3.3 feet) from the wireless access point when you are configuring the wireless settings. • If your wireless access point/router is using MAC address filtering, confirm the MAC address of this machine is allowed in the filter.	—
This machine does not support the authentication or encryption method used by the wireless access point/router.	271
Projection of the needle position by the projector is misaligned, or the camera is misaligned.	
Perform calibration.	257

■ While Operating

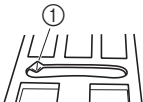
Symptom, Cause/solution	Reference
Machine does not operate.	
"Start/Stop" button was not pressed.	14
There is no stitch pattern selected.	51
There is no pattern selected.	134
Presser foot is not lowered.	14
"Start/Stop" button was pressed with the foot controller attached.	53
The "Start/Stop" button was pressed while the machine is set for the sewing speed controller to control the zigzag stitch width.	22, 53
Needle breaks.	
Needle is installed incorrectly.	36
Needle clamp screw is not tightened.	36
Needle is turned or bent.	36
Using improper needle or thread for the selected fabric.	34
Wrong presser foot was used.	273
Upper thread tension is too tight.	62, 165
Fabric is pulled during sewing.	—
Spool cap is set incorrectly.	42
There are scratches around the opening in the needle plate. * There is a notch on the left side of the opening in the needle plate. This is not a scratch.	*
	
① Notch	
There are scratches around the opening in the presser foot.	*
There are scratches on the bobbin case.	*
Needle is defective.	36
A bobbin designed specifically for this machine is not used.	37
Upper threading is incorrect.	42
Bobbin is set incorrectly.	40
Presser foot is attached incorrectly.	48
Screw of the presser foot holder is loose.	48
Fabric is too thick.	78
Fabric is fed forcefully when sewing thick fabric or thick seams.	78
Stitch length is too short.	61
Stabilizer is not attached to fabric being embroidered.	127

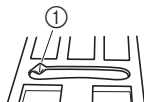
Symptom, Cause/solution	Reference
Bobbin thread is incorrectly wound.	37
Upper thread breaks.	
Machine is not threaded correctly (used the wrong spool cap, spool cap is loose, the thread did not catch the needle bar threader, etc.)	42
Knotted or tangled thread is being used.	—
The selected needle is not appropriate for the thread being used.	34
Upper thread tension is too tight.	62, 165
Thread is twisted.	—
Needle is turned, bent or the point is dull.	36
Needle is installed incorrectly.	36
There are scratches around the opening of the needle plate. * There is a notch on the left side of the opening in the needle plate. This is not a scratch.	*
	
① Notch	
There are scratches around the opening in the presser foot.	*
There are scratches on the bobbin case.	*
Using improper needle or thread for the selected fabric.	34
While sewing, the thread became knotted or tangled.	40, 42
A bobbin designed specifically for this machine is not used.	37
The ball point needle for embroidery is not being used when embroidering patterns with short stitches, such as small letters.	34
The thread is tangled on the wrong side of the fabric.	
Upper threading is incorrect.	42
Using improper needle or thread for the selected fabric.	34
The ball point needle for embroidery is not being used when embroidering patterns with short stitches, such as small letters.	34
The upper thread is too tight.	
The bobbin thread is incorrectly installed.	40
Bobbin thread breaks.	
Bobbin is set incorrectly.	40
Bobbin thread is incorrectly wound.	37
There are scratches on the bobbin or it does not rotate properly.	40
Thread is twisted.	—

Symptom, Cause/solution	Reference
A bobbin designed specifically for this machine is not used.	37
Fabric puckers.	
There is a mistake in the upper or bobbin threading.	40, 42
Spool cap is set incorrectly.	42
Using improper needle or thread for the selected fabric.	34
Needle is turned, bent or the point is dull.	36
Stitches are too long when sewing thin fabrics.	61
Thread tension is set incorrectly.	62, 165
Wrong presser foot was used.	273
The stitch is not sewn correctly.	
The presser foot that is used is not appropriate for the type of stitch that you wish to sew.	273
The thread tension is incorrect.	62
The thread is tangled, for example, in the bobbin case.	255
Skipped stitches	
Machine is threaded incorrectly.	42
Using improper needle or thread for the selected fabric.	34
Needle is turned, bent or the point is dull.	36
Needle is installed incorrectly.	36
Needle is defective.	36
Dust or lint has collected under the needle plate.	255
Thin or stretch fabrics are being sewn.	79
No stitching	
Needle is turned, bent or the point is dull.	36
Bobbin is set incorrectly.	40
Upper threading is incorrect.	42
High-pitched sound while sewing	
Dust or lint is caught in the feed dogs.	255
Pieces of thread are caught in the race.	255
Upper threading is incorrect.	42
A bobbin designed specifically for this machine is not used.	37
There are needle holes or friction scratches in the bobbin case.	255
Fabric does not feed through the machine.	
Feed dogs are set in the down position. • Touch  , and then turn the handwheel to raise the feed dogs.	111
Stitches are too close together.	61

Symptom, Cause/solution	Reference
Wrong presser foot was used.	273
Needle is turned, bent or the point is dull.	36
Thread is entangled.	262
Zigzag foot "J" is slanted on a thick seam at the beginning of stitching.	79
The embroidery foot catches on seams or the fabric. • Increase the setting specified for [Embroidery Foot Height].	25
The fabric feeds in the opposite direction.	
The feed mechanism is damaged.	*
The needle contacts the needle plate.	
The needle clamp screw is loose.	36
Needle is turned, bent or the point is dull.	36
Fabric being sewn with the machine cannot be removed.	
Thread is tangled below the needle plate.	261
A broken needle has fallen into the machine.	
Turn off the machine, and then remove the needle plate. If the needle that fell into the machine can be seen, use tweezers to remove it. After removing the needle, return the needle plate to its original position. Before turning on the machine, slowly turn the handwheel toward you to check that it turns smoothly. If the handwheel does not turn smoothly or the needle that fell into the machine cannot be removed, consult your authorized Brother dealer.	262
The handwheel feels sluggish when it is turned.	
Thread is tangled in the bobbin case.	261
The built-in camera cannot detect the buttonhole foot.	
Clean the area of the buttonhole foot to be detected.	87
Make sure that nothing obstructs the detection of mark "A+" or the three dots.	87
The machine does not detect the embroidery positioning sticker.	
Block light from the outside.	—
Make sure that nothing obstructs the embroidery positioning sticker.	
Adjust the brightness of the lighting.	
Set the fabric into the embroidery frame correctly.	
The scanned image is too bright or too pale.	
Block light from the outside.	—
It is difficult to thread the needle or remove the embroidery frame.	
Move the embroidery frame.	164

■ After Sewing/Embroidering

Symptom, Cause/solution	Reference
Thread tension is incorrect.	
Upper threading is incorrect.	42
Bobbin is set incorrectly.	40
Using improper needle or thread for the selected fabric.	34
Presser foot holder is not attached correctly.	48
Thread tension is set incorrectly.	62, 165
Bobbin thread is incorrectly wound.	37
Needle is turned, bent or the point is dull.	36
A bobbin designed specifically for this machine is not being used.	37
Character or decorative stitch patterns are misaligned.	
Stitch pattern adjustment settings were set incorrectly.	105
Stitch pattern does not turn out.	
Wrong presser foot was used.	273
Did not use a stabilizer material on thin fabrics or stretch fabrics.	80
Thread tension is set incorrectly.	62, 165
Fabric was pulled, pushed or fed at an angle while it was being sewn. <ul style="list-style-type: none"> Sew while guiding the fabric with your hands so that the fabric is fed in a straight line. 	51
The thread is tangled, for example, in the bobbin case.	261
The pattern is not embroidered correctly.	
Thread is twisted.	—
Thread tension is set incorrectly.	62, 165
Fabric was not inserted into the embroidery frame correctly (fabric was loose, etc.).	130
Stabilizing material was not attached. <ul style="list-style-type: none"> Always use stabilizing material, especially with stretch fabrics, lightweight fabrics, fabrics with a coarse weave, or fabrics that often cause pattern shrinkage. See your authorized Brother dealer for the proper stabilizer. 	127
There was an object placed near the machine, and the carriage or embroidery frame hit the object during embroidering.	126
The embroidery foot catches on seams or the fabric. <ul style="list-style-type: none"> Increase the setting specified for [Embroidery Foot Height]. 	25

Symptom, Cause/solution	Reference
Fabric outside the embroidery frame edges interferes with the machine, so the embroidery unit cannot move. <ul style="list-style-type: none"> Reinsert the fabric in the embroidery frame so that the excess fabric is away from the machine, and rotate the pattern 180 degrees. 	130
Fabric is too heavy, so the embroidery unit cannot move freely. <ul style="list-style-type: none"> Place a large thick book or similar object near the embroidery unit to lightly lift the heavy side and keep it level. Ensure that this object will not interfere with the movement of the embroidery unit or embroidery frame. 	—
Fabric is hanging off the table. <ul style="list-style-type: none"> If the fabric is hanging off the table during embroidery, the embroidery unit will not move freely. Place the fabric so that it does not hang off the table or hold the fabric to keep it from dragging. 	132
Fabric is snagged or caught on something. <ul style="list-style-type: none"> Stop the machine and place the fabric so that it does not get caught or snagged. 	—
Embroidery frame was removed during embroidering (for example, to reset the bobbin). The embroidery foot was bumped or moved while removing or attaching the embroidery frame, or the embroidery unit was moved.	162
Stabilizer is incorrectly attached, for example, it is smaller than the embroidery frame.	127
When restarting embroidering, for example, after the thread breaks, it may not be possible to continue embroidering, depending on the pattern. <ul style="list-style-type: none"> Press  (Reinforcement stitch button) to sew reinforcement stitches at the beginning of sewing, and then restart embroidering. 	163
Loops appear on the surface of the fabric when embroidering.	
The thread tension is incorrectly set.	165
The tension of the upper thread is incorrectly set for the combination of the fabric, thread and pattern being used. <ul style="list-style-type: none"> Use the embroidery needle plate cover. 	133
The combination of the bobbin case and bobbin thread is incorrect.	132

Error Messages

When erroneous operations are performed, messages and advice will be displayed on the LCD. If an error message appears, refer to the table below and take the appropriate action. If the displayed message is not listed, follow the on-screen instructions. If you touch [OK] or do the operation correctly while the error message is displayed, the message disappears. If the problem persists, contact your authorized Brother dealer or the nearest Brother authorized service center.

No.	Error messages, Cause/solution
1	<p>Attach buttonhole foot “A+”. The built-in camera detects buttonhole foot “A+” by the mark “A+” and the three dots.</p> <p>This message appears when start sewing buttonhole stitches without attaching buttonhole foot “A+”.</p>
2	<p>Cannot change the configuration of the characters.</p> <p>This message is displayed when there are too many characters and the curved character configuration is impossible.</p>
3	<p>Cannot recognize the embroidery positioning mark.</p> <p>This message is displayed when the machine failed to recognize the embroidery positioning mark.</p> <ul style="list-style-type: none"> Confirm that the embroidery positioning mark is in the selected area. Refer to steps 3 through 4 of “Using the Embroidery Positioning Sticker” on page 159. Machine failed to recognize printed positioning mark. Change the settings to print at actual size (no scaling), and try printing the embroidery positioning mark again. (page 176) Refer to “The machine does not detect the embroidery positioning sticker.” of “While Operating” on page 266.
4	<p>Change to a larger embroidery frame.</p> <p>This message is displayed when the machine is in embroidery mode and the selected pattern is too large to fit in the attached embroidery frame.</p> <p>This message may also appear while aligning an embroidery pattern using the built-in camera and the repositioned pattern does not fit in the attached embroidery frame.</p>
5	<p>Important Update Available. Update your machine by downloading the update file from the [Download the update program] in the “Machine settings”.</p> <p>There is a new update file on the server. Update the machine. (page 259)</p>
6	<p>Includes a special pattern that cannot be saved to external memory. Save the pattern in the machine’s memory.</p> <p>This message is displayed when you try to save a copyright protected pattern to USB media or computer. According to copyright laws, patterns that are illegal to reproduce or edit cannot be saved to USB media or computer. If this message displays, save the pattern in the machine’s memory.</p>

No.	Error messages, Cause/solution
7	<p>Lower the presser foot lever.</p> <p>This message is displayed when  (Presser foot lifter button) is pressed while the presser foot lever is raised and the needle is lowered.</p>
8	<p>Not enough available memory to save the data. Delete some patterns or use a different media.</p> <p>This message is displayed when the memory is full and the stitch pattern or embroidery pattern cannot be saved. To save the stitch pattern, delete a previously saved stitch pattern or embroidery pattern. (page 64, page 168)</p>
9	<p>Not enough available memory to save the data.</p> <p>This message is displayed when either the maximum number of patterns have been saved or the pattern you want to save takes a lot of memory, and the machine cannot save it. Either delete patterns from the machine’s memory or save the pattern to USB media. (page 64, page 168)</p>
10	<p>OK to recall and resume previous memory?</p> <p>This message appears if the machine is turned off while embroidering, then turned on again. Touch [OK] to return the machine to the condition (pattern position and number of stitches) when it was turned off. (page 164)</p>
11	<p>OK to recall and resume previous memory? (My Design Center)</p> <p>This message is displayed when the machine is turned off while a pattern is being edited in My Design Center, then turned on again, and then My Design Center is started. Touch [OK] to return to the screen before the machine was turned off.</p>
12	<p>OK to separate the combined border pattern?</p> <p>This message is displayed when rotating a combined border pattern in the embroidery screen.</p>
13	<p>Pattern extends to the outside of embroidery frame. Add no additional characters.</p> <p>This message is displayed when the machine is in embroidery mode, and the character pattern combination is too large to fit in the embroidery frame.</p>
14	<p>Pattern extends to the outside of embroidery frame. If you plan to add more patterns, rotate the pattern combination.</p> <p>This message is displayed when the machine is in embroidery mode and the combined character pattern is too large for the embroidery frame. You can rotate the pattern 90 degrees and continue combining characters.</p>
15	<p>Preventive maintenance is recommended.</p> <p>This message is displayed when the machine needs to be maintained.</p> <p>Once this message appears, it is recommended to take your machine to an authorized Brother dealer or the nearest Brother authorized service center for a regular maintenance check. Although this message will disappear and the machine will continue to function once you touch [OK], the message will display several more times until the appropriate maintenance is performed.</p>
16	<p>Remove Dual Feed module from the machine.</p> <p>This message appears when you try to start embroidering with the dual feed foot attached to the machine. Remove the dual feed foot before entering the embroidery mode.</p>
17	<p>Remove the embroidery frame and replace the bobbin. Next, attach the frame and touch OK to move it to the previous position.</p> <p>This message is displayed when replacing the embroidering bobbin thread. (page 162)</p>

No.	Error messages, Cause/solution
18	Remove the embroidery positioning mark. This message is displayed when the machine has recognized the embroidery position mark. Remove the embroidery positioning sticker and touch [OK] to continue. To remove the embroidery positioning sticker more easily, touch  . (page 159)
19	The "Start/Stop" button does not operate with the foot controller attached. Remove the foot controller. This message is displayed when the "Start/Stop" button is pressed to sew utility stitches or character/decorative stitches while the foot controller is connected.
20	The bobbin thread is almost empty. This message is displayed when the bobbin thread is running out. Although a few stitches can be sewn when the "Start/Stop" button is pressed, replace with a wound bobbin immediately. (page 40)
21	The bobbin thread is almost empty. * Use the "Reinforcement Stitch" button to sew a single stitch repeatedly and tie off the stitching. * Use the move frame key to move the embroidery carriage so the embroidery frame can be removed or installed. Afterward, the carriage moves back to its previous position. This message is displayed when the bobbin thread is running out. Although a few stitches can be sewn when the "Start/Stop" button is pressed, replace with a wound bobbin immediately. (page 162)
22	The bobbin winder safety device has activated. Is the thread tangled? This message is displayed when the bobbin is being wound, and the motor locks because the thread is tangled, etc.
23	The pattern extends out of the pattern area. Change position of the pattern and scan the new area. This message appears when the built-in camera is being used to align the embroidery position, but the embroidery positioning sticker is too near an edge or the pattern extends from the embroidery frame. Rehoop the fabric so that the pattern is within the embroidery field, and then try aligning the position again.
24	The pockets are full. This message is displayed when no more settings for utility stitches can be saved. In this case, erase settings that have previously been saved in order to save the new settings. (page 63)
25	The safety device has been activated. Is the thread tangled? Is the needle bent? This message is displayed when the motor locks due to tangled thread or for other reasons related to thread delivery.
26	This file cannot be used. This message appears if the file size or format is incompatible with this machine. Confirm the file size and format. (page 271)
27	This file exceeds the data capacity and cannot be used. Use a suitable size file. This message is displayed if file dimension is incompatible with machine. Confirm the file dimension and format. (page 271)

No.	Error messages, Cause/solution
28	This key cannot be used at this time. This message is displayed when you touch [Sewing Guide] in the screen other than the utility stitch, or touch [Pattern Explanation] in the screen other than the utility stitch or character/decorative stitch.
29	This pattern cannot be used. This message appears when you try to retrieve a pattern that cannot be used with this machine, such as when the data is corrupted.
30	This USB media cannot be used. This message is displayed when you try to use incompatible media. Use another USB media. For compatible USB media, refer to "Specifications" on page 271.
31	Turn off the machine before attaching or removing the needle plate. This message is displayed when you try to sew with a stitch other than a middle needle position stitch while the straight stitch needle plate is installed. This message may also appear when the needle plate is removed with the machine on or when the machine is turned on and embroidery mode is selected.
32	Update failed. Please download and install the update program again. Refer to "Updating Your Machine's Software" on page 258.
33	Update failed. Please try again installing the update program. * If the problem persists, please redownload and install the program. Refer to "Updating Your Machine's Software" on page 258.
34	USB media error This message is displayed when an error occurs with the USB media. Use another USB media. For compatible USB media, refer to "Specifications" on page 271.
35	When the speed controller is set to control the zigzag stitch width, the "Start/Stop" button does not operate. This message is displayed when the speed control slide is set to control the stitch width, and the "Start/ Stop" button is pressed. Set [Width Control] to off in the settings screen to use the "Start/Stop" button (page 22), or use the foot controller to operate the machine (page 73).
36	F** If error message [F**] appears in the LCD while the machine is being used, the machine may be malfunctioning. Contact your authorized Brother dealer or the nearest Brother authorized service center.

Chapter 8 Appendix

Specifications

Item	Specification		
Dimensions of machine	751 mm (W) × 337 mm (D) × 350 mm (H) (approx. 29-9/16 inches (W) × 13-17/64 inches (D) × 13-25/32 inches (H))		
Weight of machine	Approx. 19.7 kg (approx. 43 lb)		
Dimensions of machine with embroidery unit attached	Approx. 1090 mm (W) × 671 mm (D) × 350 mm (H) (approx. 42-29/32 inches (W) × 26-27/64 inches (D) × 13-25/32 inches (H))		
Weight of machine with embroidery unit attached	Approx. 27.0 kg (approx. 59 lb)		
Sewing speed	70 to 1050 stitches per minute		
Maximum embroidery speed	1050 stitches per minute		
Interfaces	Wireless LAN ^{*1}	None, Enhanced Open, WEP, WPA/WPA2-Personal, WPA3-Personal • A wireless network cannot be set up with WPA/WPA2/WPA3 Enterprise.	
Memory	Stitch patterns	1 MB	
	Embroidery patterns	10 MB	
	My Design Center	100 MB	
Data types ^{*2}	Sewing stitch patterns ^{*3}	.pmz, .pmp, .pmv, .pmx, .pmu	
	Embroidery patterns ^{*4}	.pes .phc .phx .dst .pen	
	Data that can be retrieved/imported when using My Design Center	• Pattern editing data (.pm9) • Motif stitch pattern data (.pmf) • Decorative fill pattern data (.plf)	
	Image data can be used for the My Design Center and Picture Play embroidery function	.jpg, .png, .bmp • Less than 6 MB and 16 million pixels or less	
Number of decorative stitch pattern combinations	Up to 70		
Maximum embroidering area	465 mm (H) × 297 mm (W) (approx. 18-1/4 inches (H) × 11-5/8 inches (W))		
Types of USB Devices/ Media that can be used	<ul style="list-style-type: none"> • USB Flash drive (Type A) Supported formats: FAT32 and NTFS Recommended size: 8 to 32 GB • Some USB media may not be usable with this machine. 		
Condition of the [Eco Mode] and [Shutoff Support Mode]	[Eco Mode]	Available time	OFF, 10 - 120 (minute)
		"Start/Stop" button	Green flashing
		Suspended function	Machine light, Screen display
		After recovering	The machine starts from the previous operation.
	[Shutoff Support Mode]	Available time	OFF, 1 - 12 (hour)
		"Start/Stop" button	Green slow flashing
		Suspended function	All functions
		After recovering	An error message appears. You need to turn off and on the machine to restart.
Compatible image files of the Screen Saver Image	Format	.jpg	
	File size	Max. 2 MB for each image	
	File dimension	800 × 1280 pixels or less (If the width is more than 800 pixels, the image imported will be reduced to a width of 800 pixels.)	
	Number allowed	5 or less	

* Please be aware that some specifications may change without notice.

- *1 The wireless network connection complies with IEEE 802.11b/g/n standards and uses the 2.4 GHz frequency. Use Design Database Transfer or PE-DESIGN version 11 or later to transfer data from your computer to the machine. For the operating systems compatible with the software, visit our website <https://s.brother/cndkb/>.
- *2 When recalling data saved with a different machine model, it may not appear as it was saved. Check the recalled data.
- *3 “.pmp”, “.pmv”, “.pmu” or “.pmx” stitch data files can be retrieved; however, when the machine is used to save the file, it is saved as a “.pmz” stitch data file. Using data other than what was created using this machine or the machine which create “.pmp”, “.pmv”, “.pmx” or “.pmu” data file, may cause the machine to malfunction.
- *4 Using data other than that saved using our data design systems or this machine may cause this machine to malfunction. When the machine is used to save a file with any extension, it is saved as a .phx data file. Since Tajima (.dst) data does not contain specific thread color information, it is displayed with our default thread color sequence. Check the preview and change the thread colors as desired.

 **Note**



- We recommend using the 26 letters of the alphabet (uppercase and lowercase), the numbers 0 through 9, “-”, and “_” for the name of the file/folder.
-

IMPORTANT











- When using embroidery data other than our original patterns, the thread may break or the needle may bend or break when embroidering with a stitch density that is too fine or when embroidering three or more overlapping stitches. In that case, use one of our original data design systems to edit the embroidery data.









Stitch Chart

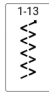

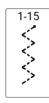
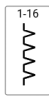
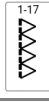
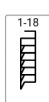

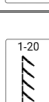



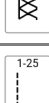
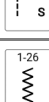





Memo

















- For details on automatic reverse/reinforcement stitching for each stitch, refer to “Automatic Reverse/Reinforcement Stitching” on page 56.
- The presser foot that is displayed on each screen when Free motion mode is  (off) or  (on) is shown in the table under “Presser foot”.

















Utility stitches with “*” under “Presser foot” in the following table can be used with a twin needle if zigzag foot “J” is attached.

















Stitch	Presser foot	Stitch name/ Applications	Stitch width (mm)	Stitch length (mm)
			Auto. Manual	Auto. Manual
	J*/O	Straight stitch (Left) General sewing, gather, pintuck, etc.	—	2.5 0.2 - 5.0
	J*/O	Straight stitch (Left) General sewing, gather, pintuck, etc.	—	2.5 0.2 - 5.0
	J*/O	Straight stitch (Middle) General sewing, gather, pintuck, etc.	—	2.5 0.2 - 5.0
	J*/O	Straight stitch (Middle) General sewing, gather, pintuck, etc.	—	2.5 0.2 - 5.0
	J*/O	Triple stretch stitch General sewing for reinforcement and decorative topstitching	—	2.5 0.4 - 5.0
	J*/O	Stem stitch Reinforced stitching, sewing and decorative applications	1.0 0.0 - 7.0	2.5 0.4 - 5.0
	N+*/O	Decorative stitch Decorative stitching, top stitching	—	2.5 0.4 - 5.0
	J/O	Basting stitch Basting	—	5.0 5.0
	J*/O	Zigzag stitch For overcasting, mending.	3.5 0.0 - 7.0	1.4 0.0 - 5.0
	J*/O	Zigzag stitch For overcasting, mending.	3.5 0.0 - 7.0	1.4 0.0 - 5.0
	J*/O	Zigzag stitch (Right) Start from right needle position, zigzag sew at left.	3.5 2.5 - 5.0	1.4 0.3 - 5.0















Stitch	Presser foot	Stitch name/ Applications	Stitch width (mm)	Stitch length (mm)
			Auto. Manual	Auto. Manual
	J*/O	Zigzag stitch (Left) Start from left needle position, zigzag sew at right.	3.5 2.5 - 5.0	1.4 0.3 - 5.0
	J*/O	2 steps elastic zigzag Overcasting (medium weight and stretch fabrics), tape and elastic	5.0 0.0 - 7.0	1.0 0.2 - 5.0
	J*/O	2 steps elastic zigzag Overcasting (medium weight and stretch fabrics), tape and elastic	5.0 0.0 - 7.0	1.0 0.2 - 5.0
	J*/O	3 steps elastic zigzag Overcasting (medium, heavyweight and stretch fabrics), tape and elastic	5.0 0.0 - 7.0	1.0 0.2 - 5.0
	G	Overcasting stitch Reinforcing of light and medium weight fabrics	3.5 2.5 - 5.0	2.0 0.4 - 5.0
	G	Overcasting stitch Reinforcing of heavyweight fabric	5.0 2.5 - 5.0	2.5 0.4 - 5.0
	G	Overcasting stitch Reinforcing of medium, heavyweight and easily friable fabrics or decorative stitching.	5.0 3.5 - 5.0	2.5 0.4 - 5.0
	J*/O	Overcasting stitch Reinforced seaming of stretch fabric	5.0 0.0 - 7.0	2.5 0.4 - 5.0
	J*/O	Overcasting stitch Reinforcing of medium stretch fabric and heavyweight fabric, decorative stitching	5.0 0.0 - 7.0	2.5 0.4 - 5.0
	J*/O	Overcasting stitch Reinforcement of stretch fabric or decorative stitching	4.0 0.0 - 7.0	4.0 0.4 - 5.0
	J/O	Overcasting stitch Stretch knit seam	5.0 0.0 - 7.0	4.0 0.4 - 5.0
	J*/O	Single diamond overcast Reinforcement and seaming stretch fabric	6.0 0.0 - 7.0	3.0 0.4 - 5.0
	J*/O	Single diamond overcast Reinforcement of stretch fabric	6.0 0.0 - 7.0	1.8 0.4 - 5.0
	S	With side cutter Straight stitch while cutting fabrics	—	2.5 0.2 - 5.0
	S	With side cutter Zigzag stitch while cutting fabrics	3.5 3.5 - 5.0	1.4 0.0 - 5.0















Stitch	Presser foot	Stitch name/ Applications	Stitch width (mm)	Stitch length (mm)
			Auto. Manual	Auto. Manual
	S	With side cutter Overcasting stitch while cutting fabrics	3.5 3.5 - 5.0	2.0 0.4 - 5.0
	S	With side cutter Overcasting stitch while cutting fabrics	5.0 3.5 - 5.0	2.5 0.4 - 5.0
	S	With side cutter Overcasting stitch while cutting fabrics	5.0 3.5 - 5.0	2.5 0.4 - 5.0
	J/O	Piecing stitch (Right) Piecework/patchwork 6.5 mm (approx. 1/4 inch) right seam allowance	—	2.0 0.2 - 5.0
	J/C	Piecing stitch (Middle) Piecework/patchwork * Be sure to use the straight stitch needle plate when using free motion quilting foot "C".	—	2.0 0.2 - 5.0
	J/O	Piecing stitch (Left) Piecework/patchwork 6.5 mm (approx. 1/4 inch) left seam allowance	—	2.0 0.2 - 5.0
	J/O	Hand-look quilting Quilting stitch made to look like hand quilting stitch	—	2.5 0.4 - 5.0
	J/O	Quilting appliqué zigzag stitch Zigzag stitch for quilting and sewing on appliqué quilt pieces	3.5 0.0 - 7.0	1.4 0.0 - 5.0
	J/O	Quilting appliqué stitch Quilting stitch for invisible appliqué or attaching binding	1.5 0.0 - 7.0	1.8 0.4 - 5.0
	J/O	Quilting stippling Background quilting	7.0 0.0 - 7.0	1.6 0.4 - 5.0
	R	Blind hem stitch Hemming woven fabrics * The stitch width setting is in neither millimeters nor inches.	00 3 ← - → 3	2.0 0.4 - 5.0
	R	Blind hem stitch stretch Hemming stretch fabric * The stitch width setting is in neither millimeters nor inches.	00 3 ← - → 3	2.0 0.4 - 5.0
	J*/O	Blanket stitch Appliqués, decorative blanket stitch	3.5 0.0 - 7.0	2.5 0.4 - 5.0
	J*/O	Blanket stitch Appliqués, decorative blanket stitch	2.5 0.0 - 7.0	2.5 0.4 - 5.0
	J*/O	Shell tuck edge Shell tuck edge finish on fabrics	4.0 0.0 - 7.0	2.5 0.2 - 5.0

Stitch	Presser foot	Stitch name/ Applications	Stitch width (mm)	Stitch length (mm)
			Auto. Manual	Auto. Manual
	N+*/O	Satin scallop stitch Decorating collar of blouse, edge of handkerchief	5.0 0.0 - 7.0	0.5 0.1 - 5.0
	N+*/O	Scallop stitch Decorating collar of blouse, edge of handkerchief	7.0 0.0 - 7.0	1.4 0.4 - 5.0
	J*/O	Patchwork join stitch Patchwork stitches, decorative stitching	4.0 0.0 - 7.0	1.2 0.2 - 5.0
	J*/O	Patchwork double overlock stitch Patchwork stitches, decorative stitching	5.0 0.0 - 7.0	2.5 0.4 - 5.0
	J*/O	Couching stitch Decorative stitching, attaching cord and couching	5.0 0.0 - 7.0	1.2 0.2 - 5.0
	J*/O	Smocking stitch Smocking, decorative stitching	5.0 0.0 - 7.0	1.6 0.4 - 5.0
	J*/O	Feather stitch Fagoting, decorative stitching	5.0 0.0 - 7.0	2.5 0.4 - 5.0
	J*/O	Fagoting cross stitch Fagoting, bridging and decorative stitching	5.0 0.0 - 7.0	2.5 0.4 - 5.0
	J*/O	Tape attaching Attaching tape to seam in stretch fabric	4.0 0.0 - 7.0	1.0 0.2 - 5.0
	N+*/O	Ladder stitch Decorative stitching	4.0 0.0 - 7.0	3.0 0.4 - 5.0
	J*/O	Rick-rack stitch Decorative top stitching	4.0 0.0 - 7.0	2.5 0.4 - 5.0
	J*/O	Decorative stitch Decorative stitching	1.0 0.0 - 7.0	2.5 0.4 - 5.0
	J*/O	Decorative stitch Decorative stitching	5.5 0.0 - 7.0	1.6 0.4 - 5.0
	N+*/O	Serpentine stitch Decorative stitching and attaching elastic	5.0 0.0 - 7.0	1.0 0.2 - 5.0
	N+*/O	Decorative stitch Decorative stitching and appliqué	6.0 0.0 - 7.0	1.0 0.2 - 5.0
	N+*/O	Decorative stippling stitch Decorative stitching	7.0 0.0 - 7.0	1.6 0.4 - 5.0

Stitch	Presser foot	Stitch name/ Applications	Stitch width (mm)	Stitch length (mm)
			Auto. Manual	Auto. Manual
	N+*/O	Hemstitching Decorative hems, triple straight at left	—	2.5 0.4 - 5.0
	N+*/O	Hemstitching Decorative hems, triple straight at center	—	2.5 0.4 - 5.0
	N+*/O	Hemstitching zigzag Decorative hems, top stitching	6.0 0.0 - 7.0	3.0 0.4 - 5.0
	N+*/O	Hemstitching Decorative hems, lace attaching pin stitch	3.5 0.0 - 7.0	2.5 0.4 - 5.0
	N+*/O	Hemstitching Decorative hems	3.0 0.0 - 7.0	3.5 0.4 - 5.0
	N+*/O	Hemstitching Decorative hems daisy stitch	6.0 0.0 - 7.0	3.0 0.4 - 5.0
	N+*/O	Hemstitching Heirloom, decorative hems	5.0 0.0 - 7.0	3.5 0.4 - 5.0
	N+*/O	Hemstitching Heirloom, decorative hems	5.0 0.0 - 7.0	3.5 0.4 - 5.0
	N+*/O	Hemstitching Heirloom, decorative hems	5.0 0.0 - 7.0	3.5 0.4 - 5.0
	N+*/O	Hemstitching Heirloom, decorative hems	5.0 0.0 - 7.0	4.0 0.4 - 5.0
	N+*/O	Hemstitching Heirloom, decorative hems	4.0 0.0 - 7.0	2.5 0.4 - 5.0
	N+*/O	Honeycomb stitch Heirloom, decorative hems	5.0 0.0 - 7.0	2.5 0.4 - 5.0
	N+*/O	Honeycomb stitch Heirloom, decorative hems	6.0 0.0 - 7.0	3.5 0.4 - 5.0
	N+*/O	Hemstitching Heirloom, decorative hems	6.0 0.0 - 7.0	1.6 0.4 - 5.0
	N+*/O	Hemstitching Heirloom, decorative hems	6.0 0.0 - 7.0	3.0 0.4 - 5.0
	N+*/O	Hemstitching Heirloom, decorative hems	6.0 0.0 - 7.0	4.0 0.4 - 5.0

















Stitch	Presser foot	Stitch name/ Applications	Stitch width (mm)	Stitch length (mm)
			Auto. Manual	Auto. Manual
	N+*/O	Hemstitching Heirloom, decorative hems	4.0 0.0 - 7.0	2.5 0.4 - 5.0
	N+*/O	Hemstitching Heirloom, decorative hems	5.0 0.0 - 7.0	2.0 0.4 - 5.0
	N+*/O	Hemstitching Decorative hems and bridging stitch	6.0 0.0 - 7.0	2.0 0.4 - 5.0
	N+*/O	Hemstitching Decorative hems. Fagoting, attaching ribbon	5.0 0.0 - 7.0	3.0 0.4 - 5.0
	N+*/O	Hemstitching Decorative hems, smocking	6.0 0.0 - 7.0	1.6 0.4 - 5.0
	N+*/O	Hemstitching Decorative hems, smocking	5.0 0.0 - 7.0	1.6 0.4 - 5.0
	N+*/O	Hemstitching Decorative hems, smocking	5.0 0.0 - 7.0	1.6 0.4 - 5.0
	N+*/O	Hemstitching Decorative hems	5.0 0.0 - 7.0	1.6 0.4 - 5.0
	N+*/O	Ladder stitch Decorative hems. Fagoting, attaching ribbon	7.0 0.0 - 7.0	1.6 0.4 - 2.5
	A+	Narrow rounded buttonhole Buttonhole on light to medium weight fabrics	5.0 3.0 - 6.5	0.4 0.2 - 1.0
	A+	Wide round ended buttonhole Buttonholes with extra space for larger buttons	5.5 3.5 - 6.5	0.4 0.2 - 1.0
	A+	Tapered round ended buttonhole Reinforced waist tapered buttonholes	5.0 3.0 - 6.5	0.4 0.2 - 1.0
	A+	Round ended buttonhole Buttonholes with vertical bar tack in heavyweight fabrics	5.0 3.0 - 6.5	0.4 0.2 - 1.0
	A+	Round ended buttonhole Buttonholes with bar tack	5.0 3.0 - 6.5	0.4 0.2 - 1.0
	A+	Round double ended buttonhole Buttonholes for fine, medium to heavyweight fabrics	5.0 3.0 - 6.5	0.4 0.2 - 1.0
	A+	Narrow squared buttonhole Buttonholes for light to medium weight fabrics	5.0 3.0 - 6.5	0.4 0.2 - 1.0















Stitch	Presser foot	Stitch name/ Applications	Stitch width (mm)	Stitch length (mm)
			Auto. Manual	Auto. Manual
	A+	Wide squared buttonhole Buttonholes with extra space for larger decorative buttons	5.5 3.5 - 6.5	0.4 0.2 - 1.0
	A+	Squared buttonhole Heavy-duty buttonholes with vertical bar tacks	5.0 3.0 - 6.5	0.4 0.2 - 1.0
	A+	Stretch buttonhole Buttonholes for stretch or woven fabrics	6.0 3.0 - 6.5	1.0 0.5 - 2.0
	A+	Heirloom buttonhole Buttonholes for heirloom and stretch fabrics	6.0 3.0 - 6.5	1.5 1.0 - 3.0
	A+	Bound buttonhole The first step in making bound buttonholes	5.0 0.0 - 6.5	2.0 0.2 - 4.0
	A+	Keyhole buttonhole Buttonholes in heavyweight or thick fabrics for larger flat buttons	7.0 3.0 - 7.0	0.5 0.3 - 1.0
	A+	Tapered keyhole buttonhole Buttonholes in medium to heavy weight fabrics for larger flat buttons	7.0 3.0 - 7.0	0.5 0.3 - 1.0
	A+	Keyhole buttonhole Buttonholes with vertical bar tack for reinforcement in heavyweight or thick fabrics	7.0 3.0 - 7.0	0.5 0.3 - 1.0
	N+/O	4 steps buttonhole 1 Left side of 4 step buttonhole	5.0 1.5 - 7.0	0.4 0.2 - 1.0
	N+/O	4 steps buttonhole 2 Bar tack of 4 step buttonhole	5.0 1.5 - 7.0	0.4 0.2 - 1.0
	N+/O	4 steps buttonhole 3 Right side of 4 step buttonhole	5.0 1.5 - 7.0	0.4 0.2 - 1.0
	N+/O	4 steps buttonhole 4 Bar tack of 4 step buttonhole	5.0 1.5 - 7.0	0.4 0.2 - 1.0
	A+	Darning Darning of medium weight fabric	7.0 2.5 - 7.0	2.0 0.4 - 2.5
	A+	Darning Darning of heavyweight fabric	7.0 2.5 - 7.0	2.0 0.4 - 2.5
	A+	Bar tack Reinforcement at opening of pocket, etc.	2.0 1.0 - 3.0	0.4 0.3 - 1.0





Stitch	Presser foot	Stitch name/ Applications	Stitch width (mm)	Stitch length (mm)
			Auto. Manual	Auto. Manual
	M	Button sewing Attaching buttons	3.5 2.5 - 4.5	—
	N+/O	Eyelet For making eyelets, holes on belts, etc.	7.0 5.0 6.0 7.0	7.0 5.0 6.0 7.0
	N+/O	Star eyelet For making star-shaped eyelets on holes.	—	—
	N+/O	Diagonally left up (Straight) For attaching appliqué on tubular pieces of fabric and mitering corners	—	—
	N+/O	Reverse (Straight) For attaching appliqué on tubular pieces of fabric and mitering corners	—	—
	N+/O	Diagonally right up (Straight) For attaching appliqué on tubular pieces of fabric and mitering corners	—	—
	N+/O	Sideways to left (Straight) For attaching appliqué on tubular pieces of fabric	—	—
	N+/O	Sideways to right (Straight) For attaching appliqué on tubular pieces of fabric	—	—
	N+/O	Diagonally left down (Straight) For attaching appliqué on tubular pieces of fabric and mitering corners	—	—
	N+/O	Forward (Straight) For attaching appliqué on tubular pieces of fabric and mitering corners	—	—
	N+/O	Diagonally right down (Straight) For attaching appliqué on tubular pieces of fabric and mitering corners	—	—
	N+/O	Sideways to left (Zigzag) For attaching appliqué on tubular pieces of fabric	—	—
	N+/O	Sideways to right (Zigzag) For attaching appliqué on tubular pieces of fabric	—	—
	N+/O	Forward (Zigzag) For attaching appliqué on tubular pieces of fabric and mitering corners	—	—
	N+/O	Reverse (Zigzag) For attaching appliqué on tubular pieces of fabric and mitering corners	—	—

Stitch	Presser foot	Stitch name/ Applications	Stitch width (mm)	Stitch length (mm)
			Auto. Manual	Auto. Manual
	J/C	Piecing stitch (Middle) Piecework/patchwork	—	2.0 0.2 - 5.0
	J/O	Piecing stitch (Right) Piecework/patchwork 6.5 mm (approx. 1/4 inch) right seam allowance	—	2.0 0.2 - 5.0
	J/O	Piecing stitch (Left) Piecework/patchwork 6.5 mm (approx. 1/4 inch) left seam allowance	—	2.0 0.2 - 5.0
	J/O	Hand-look quilting Quilting stitch made to look like hand quilting stitch	—	2.5 0.4 - 5.0
	J/O	Basting stitch Basting	—	5.0 5.0
	J/O	Stem stitch Reinforced stitching, sewing and decorative applications	1.00 0.00 - 7.00	2.5 0.4 - 5.0
	J/O	Quilting appliqué zigzag stitch Zigzag stitch for quilting and sewing on appliqué quilt pieces	3.50 0.00 - 7.00	1.6 0.0 - 5.0
	J/O	Zigzag stitch (Right) Start from right needle position, zigzag sew at left	3.50 2.50 - 5.00	1.6 0.3 - 5.0
	J/O	Zigzag stitch (Left) Start from left needle position, zigzag sew at right	3.50 2.50 - 5.00	1.6 0.3 - 5.0
	J/O	2 steps elastic zigzag Overcasting (medium weight and stretch fabrics), tape and elastic	5.00 0.00 - 7.00	1.0 0.2 - 5.0
	J/O	3 steps elastic zigzag Overcasting (medium, heavyweight and stretch fabrics), tape and elastic	5.00 0.00 - 7.00	1.0 0.2 - 5.0
	J/O	Quilting appliqué stitch Quilting stitch for invisible appliqué or attaching binding	2.00 0.00 - 7.00	2.0 0.4 - 5.0
	J/O	Shell tuck edge Shell tuck edge finish on fabrics	4.00 0.00 - 7.00	2.5 0.2 - 5.0
	J/O	Blanket stitch Appliqués, decorative blanket stitch	3.50 0.00 - 7.00	2.5 0.4 - 5.0
	J/O	Quilting stippling Background quilting	7.00 0.00 - 7.00	1.6 0.4 - 5.0
	J/O	Overcasting stitch Stretch knit seam	5.00 0.00 - 7.00	4.0 0.4 - 5.0

Stitch	Presser foot	Stitch name/ Applications	Stitch width (mm)	Stitch length (mm)
			Auto. Manual	Auto. Manual
	J/O	Tape attaching Attaching tape to seam in stretch fabric	5.50 0.00 - 7.00	1.4 0.2 - 5.0
	N+/O	Serpentine stitch Decorative stitching and attaching elastic	5.00 0.00 - 7.00	2.0 0.2 - 5.0
	J/O	Feather stitch Fagoting, decorative stitching	5.00 0.00 - 7.00	2.5 0.4 - 5.0
	J/O	Fagoting cross stitch Fagoting, bridging and decorative stitching	5.00 0.00 - 7.00	2.5 0.4 - 5.0
	J/O	Couching stitch Decorative stitching, attaching cord and couching	5.00 0.00 - 7.00	1.2 0.2 - 5.0
	J/O	Patchwork double overlock stitch Patchwork stitches, decorative stitching	5.00 0.00 - 7.00	2.5 0.4 - 5.0
	J/O	Smocking stitch Smocking, decorative stitching	5.00 0.00 - 7.00	1.6 0.4 - 5.0
	J/O	Rick-rack stitch Decorative top stitching	4.00 0.00 - 7.00	2.5 0.4 - 5.0
	N+/O	Decorative stitch Decorative stitching and appliqué	6.00 0.00 - 7.00	1.0 0.2 - 5.0
	J/O	Decorative stitch Decorative stitching	5.50 0.00 - 7.00	1.6 0.4 - 5.0
	N+/O	Hemstitching Heirloom, decorative hems	5.00 0.00 - 7.00	2.0 0.4 - 5.0
	N+/O	Hemstitching Decorative hems and bridging stitch	6.00 0.00 - 7.00	2.0 0.4 - 5.0
	J/O	Single diamond overcast Reinforcement and seaming stretch fabric	6.00 0.00 - 7.00	3.0 0.4 - 5.0
	J/O	Overcasting stitch Reinforcement of stretch fabric or decorative stitching	4.00 0.00 - 7.00	4.0 0.4 - 5.0
	N+/O	Appliqué stitch Appliqués, decorative stitch	3.00 0.00 - 7.00	2.0 0.4 - 5.0
	N+*/O	Blanket stitch Appliqué, decorative blanket stitch	4.00 0.00 - 7.00	2.5 0.4 - 5.0

Stitch	Presser foot	Stitch name/ Applications	Stitch width (mm)	Stitch length (mm)
			Auto. Manual	Auto. Manual
	N+/O	Decorative stitch Decorative stitching	7.00 0.00 - 7.00	2.5 0.4 - 5.0
	N+/O	Decorative stitch Decorative stitching	7.00 0.00 - 7.00	2.5 0.4 - 5.0
	N+/O	Decorative stitch Decorative stitching	7.00 0.00 - 7.00	2.5 0.4 - 5.0
	N+/O	Decorative stitch Decorative stitching	7.00 0.00 - 7.00	2.5 0.4 - 5.0
	N+/O	Decorative stitch Decorative stitching	7.00 0.00 - 7.00	2.5 0.4 - 5.0
	N+/O	Decorative stitch Decorative stitching	7.00 0.00 - 7.00	2.5 0.4 - 5.0
	N+*/O	Decorative stitch Decorative stitching	7.00 0.00 - 7.00	2.5 0.4 - 5.0
	N+*/O	Decorative stitch Decorative stitching	7.00 0.00 - 7.00	0.4 0.1 - 5.0
	X	Free motion couching stitch Free motion couching stitch	—	—
	N+	Free-motion basting Free motion basting stitch	—	—
	J/O	Hand-look quilting Quilting stitch made to look like hand quilting stitch	—	—
	J/O	Hand-look quilting Quilting stitch made to look like hand quilting stitch	—	—
	J/O	Hand-look quilting Quilting stitch made to look like hand quilting stitch	—	—
	N+/O	Tapering stitch Stitch pattern can be tapered at the beginning or at the end of sewing.	7.0 2.5 - 7.0	1.0 0.1 - 5.0
	N+/O	Tapering stitch Stitch pattern can be tapered at the beginning or at the end of sewing.	5.0 2.5 - 7.0	2.5 1.4 - 5.0
	N+/O	Tapering stitch Stitch pattern can be tapered at the beginning or at the end of sewing.	5.0 2.5 - 7.0	2.5 1.4 - 4.0

Stitch	Presser foot	Stitch name/ Applications	Stitch width (mm)	Stitch length (mm)
			Auto. Manual	Auto. Manual
	N+/O	Tapering stitch Stitch pattern can be tapered at the beginning or at the end of sewing.	7.0 2.5 - 7.0	2.0 1.0 - 4.0
	N+/O	Tapering stitch Stitch pattern can be tapered at the beginning or at the end of sewing.	7.0 2.5 - 7.0	3.5 2.5 - 4.0
	N+/O	Tapering stitch Stitch pattern can be tapered at the beginning or at the end of sewing.	7.0 2.5 - 7.0	3.0 2.0 - 5.0
	N+/O	Tapering stitch Stitch pattern can be tapered at the beginning or at the end of sewing.	7.0 3.0 - 7.0	3.0 2.5 - 5.0
	N+/O	Tapering stitch Stitch pattern can be tapered at the beginning or at the end of sewing.	7.0 3.0 - 7.0	2.5 2.5 - 4.0
	N+/O	Tapering stitch Stitch pattern can be tapered at the beginning or at the end of sewing.	7.0 2.5 - 7.0	2.5 1.4 - 4.0
	N+/O	Tapering stitch Stitch pattern can be tapered at the beginning or at the end of sewing.	7.0 3.0 - 7.0	2.5 2.0 - 4.0
	N+/O	Tapering stitch Stitch pattern can be tapered at the beginning or at the end of sewing.	7.0 4.0 - 7.0	3.0 2.5 - 4.0
	N+/O	Tapering stitch Stitch pattern can be tapered at the beginning or at the end of sewing.	7.0 2.5 - 7.0	1.0 0.4 - 5.0
	N+/O	Tapering stitch Stitch pattern can be tapered at the beginning or at the end of sewing.	6.0 4.0 - 7.0	0.3 0.2 - 2.0
	N+/O	Tapering stitch Stitch pattern can be tapered at the beginning or at the end of sewing.	6.0 4.0 - 7.0	0.3 0.2 - 2.0
	N+/O	Tapering stitch Stitch pattern can be tapered at the beginning or at the end of sewing.	7.0 3.5 - 7.0	0.3 0.1 - 2.0
	N+/O	Tapering stitch Stitch pattern can be tapered at the beginning or at the end of sewing.	7.0 4.0 - 7.0	3.5 2.5 - 4.0
	N+/O	Tapering stitch Stitch pattern can be tapered at the beginning or at the end of sewing.	7.0 4.0 - 7.0	2.5 2.0 - 4.0
	N+/O	Tapering stitch Stitch pattern can be tapered at the beginning or at the end of sewing.	7.0 4.5 - 7.0	2.5 2.0 - 4.0

Stitch	Presser foot	Stitch name/ Applications	Stitch width (mm)	Stitch length (mm)
			Auto. Manual	Auto. Manual
	N+/O	Tapering stitch Stitch pattern can be tapered at the beginning or at the end of sewing.	7.0 2.5 - 7.0	2.5 1.6 - 4.0
	N+/O	Tapering stitch Stitch pattern can be tapered at the beginning or at the end of sewing.	7.0 4.0 - 7.0	2.5 2.0 - 4.0
	SR	Straight stitch (Middle) Straight stitch for the stitch regulator mode	—	2.5 1.0 - 4.5
	SR	Zigzag stitch Zigzag stitch for the stitch regulator mode	2.5 0.0 - 3.0	1.6 1.0 - 3.0
	SR	Free-motion basting Basting stitch for the stitch regulator mode	—	20.0 10.0 - 30.0

INDEX

A

Accessory case	14
Accessory compartment	15
Adapter	48
Advanced multi-function foot controller	53
Aligning the position	157, 159, 161
Alphabet characters	59, 137
Appliqué	107, 184
Appliqué piece	184
Apps	225
Automatic fabric sensor system	73
Automatic reinforcement stitching	56
Automatic thread cutting	58, 141
Automatic threading button	14, 42

B

Ball point needle	34
Bar tack	93
Basting	95, 114, 173
Blind hem stitches	85
Bobbin	
pulling up the bobbin thread	41
runs out of thread	162
setting	40
winding	37
Bobbin case	132
cleaning	255
Bobbin cover	13, 40, 82, 83
Bobbin thread	132
Border function (designing repeated patterns)	150
Button sewing	92
Buttonholes	
embroidery	136
four-step	91
odd-shaped/buttons that do not fit the button holder plate	89
one-step	87

C

Camera	74, 161
Character spacing	21, 144
Character/Decorative stitches	
adjustments	105
retrieving	64
saving	64
Cleaning	255
Clock	16
Color shuffling function	169
Combining patterns	147
Combining stitch patterns	59
Compact dual feed foot	49, 111
Connecting patterns	212
Cord guide bobbin cover	83
Couching	101, 191
Cylindrical pieces	78

D

Darning	93
Decorative fill pattern	194, 234, 236
Denim	34, 79
Dual purpose stylus	15, 70, 155

E

Echo quilting	113, 194
Eco mode	27
Edge-to-edge quilt function	195

Embroidery

adjusting the speed	133
aligning the position	157
appliqué	184, 187, 189
automatic thread cutting function (end color trim)	141
changing the thread color	169
checking the position	139
combined patterns	147
combining	147
editing	142
key functions	142
linked characters	174
repeated patterns	150
retrieving	168
saving	167
thread trimming function (jump stitch trim)	141
Embroidery foot "W"	125
Embroidery frames	
attaching/removing	131
inserting fabric	130
using the embroidery sheet	131
Embroidery needle plate cover	133
Embroidery positioning sticker	159, 212
Embroidery sheet	131
Embroidery unit	14
carriage	14
End point setting	75
Error messages	269
Eyelet	94, 136

F

Fabrics	
fabric/thread/needle combinations	34
sewing heavyweight fabrics	78
sewing lightweight fabrics	79
sewing stretch fabrics	79, 90
Feed dogs	13, 111
File format	271
Flat bed attachment	13, 126
Font	137
Foot controller	53
Forward/Back key	163
Free motion quilting	
free motion echo quilting foot "E"	113
free motion open toe quilting foot "O"	113
free motion quilting foot "C"	112
Free motion sewing mode	111

G

Gathering	108
Guidelines	65

H

Handle	13
Hand-look quilting	119
Handwheel	13
Home page screen	18

I

Importing decorative fill pattern data	236
Importing motif stitch pattern data	236
Included accessories	14

K

Key functions	
embroidery	142
MY CUSTOM STITCH	121
My Design Center	230
utility stitches	19
Knee lifter	13, 72

L

L/R Shift	61
Language	23
Large-size split embroidery patterns	212
LCD screen	13, 17
Leather	79
Light	23

M

Machine help key	29
Machine number	258
Main power switch	13, 16
Memory	64, 167
Metallic thread	35, 42
Motif stitch pattern	233, 236
Multi-directional sewing	103
Multi-purpose screwdriver	15
MY CUSTOM STITCH	120
My Design Center	227
create a pattern	241
key functions	230
line and region settings	239
My Design Snap App	225
My Stitch Monitor App	225

N

Needle	
ball point needle	34
changing the needle	36
changing the needle position	81
checking the needle location	74
fabric/thread/needle combinations	34
twin needle	106
Needle bar thread guide	13, 106
Needle calibration	257
Needle clamp screw	13
Needle plate	13, 255
Needle position	75, 81
Needle position button	14
No sew setting	171

O

Operation buttons	14
Overcasting	84

P

Picture Play embroidery function	177
Piecing	110
Pivoting	72
Power cord	16
Presser foot	
pressure	73
removing	48
types	273
Presser foot holder	13, 48
Presser foot holder screw	13
Presser foot lever	13
Presser foot lifter button	14
Presser foot/Needle exchange key	36, 48, 106
Pretension disk	13, 37, 39
Preview key	121, 153

Print and stitch	175
Projector	
embroidery pattern	154
guidelines	65
needle drop point	139
projector edit with stylus	155
stitch pattern	70

Q

Quilting	110
compact dual feed foot	111
embroidery	194
free motion	111
stitch regulator	114
Quilting border patterns	201, 203, 208

R

Race	255
Reinforcement stitch	55
Reinforcement stitch button	14, 56
Repeated patterns	150
Retrieving	
character/decorative stitches	64
embroidery patterns	168
MY CUSTOM STITCH designs	123
utility stitch settings	63
Reverse stitch button	14, 56
Reverse/Reinforcement stitches	55

S

Saving	
character/decorative stitches	64
embroidery patterns	167
MY CUSTOM STITCH designs	123
utility stitch settings	63
Scallop stitches	109
Scan	
background image	157, 243
using the scanning frame	241
Screen saver	27
Settings	
automatic thread cutting	58, 141
embroidery settings	25
general settings	23
machine settings key	22
sewing settings	22
Sewing speed controller (speed control slide)	14, 51
Shell tuck stitches	109
Shutoff support mode	27
Specifications	271
Speed	14, 133
Spool cap	13
Spool net	35
Spool pin	13
Spool stand	45
Stabilizer	127
Start/Stop button	14
Step stitch patterns	104
Stippling	194, 227
Stitch chart	273
Stitch regulator	114
Stitch tapering function	98
Stitch types	51
Straight stitch foot	82
Straight stitch needle plate	82
Straight stitches	81
Stretch fabrics	79
Supplemental spool pin	13, 37
Support table	126

T

Tape or elastic attaching	108
Thick fabrics	78
Thin fabrics	79
Thread	
fabric/thread/needle combinations	34
thread tension	62, 165
Thread color sorting	170
Thread cutter	13, 51
Thread cutter button	14
Thread density	21, 143
Thread guide	13, 37, 39
Thread guide plate	13, 39, 42
Thread marks	152
Tooltip	17
Top cover	13
Trace area key	139
Transparent nylon thread	34
Troubleshooting	260
Twin needle	106

U

Uninterrupted embroidering	171
Updating	258
Upper threading	42
USB media	64, 167
USB mouse	17
Utility stitches	
key functions	19
retrieving	63
saving	63
stitch chart	273

V

Video	30
Vinyl fabrics	79
Voice Guidance	28
Volume	23

W

Width Control	73
Wireless network connection	31

Z

Zigzag stitches	83
Zipper insertion	95





Various optional accessories are available to be purchased separately.

Visit our website <https://s.brother/codkb/> .



Please visit us at <https://s.brother/cpdae/> where you can get product support and answers to frequently asked questions (FAQs).



Be sure to install the latest software.

A variety of functional improvements are being performed in the latest version.

This machine is approved for use in the country of purchase only. Local Brother companies or their dealers will only support machines purchased in their own countries.