



JK-2290D系列

产品使用说明书&产品零件图册

Manual book & parts book

JACK 杰克

CONTENTS

目 录

1. FRAME & MISCELLANEOUS COVER COPONENTS(1)	1
机体部分(1)	
2. FRAME & MISCELLANEOUS COVER COPONENTS(2)	3
机体部分(2)	
3. MAIN SHAFT & THREAD TAKE-UP & NEEDLE BAR COMPONENTS	5
挑线刺布部件	
4. NEEDLE VIBRATOR COMPONENTS	7
摆针部件	
5. HAND LIFTER COMPONENTS	9
抬压脚部件	
6. FEED MECHANISM COMPONENTS(1)	11
倒送料部件(1)	
7. FEED MECHANISM COMPONENTS(2)	13
针距部件	
8. FEED MECHANISM COMPONENTS(3)	15
针距部件	
10. HOOK DRIVING SHAFT COMPONENTS(1)	17
下轴部件(1)	
11. HOOK DRIVING SHAFT COMPONENTS(2)	19
下轴部件(2)	
12. THREAD TRIMMER MECHANISM COMPONENTS	21
切刀部件	
14. AUTOMATIC REVERSE FEED MACHANISM COMPINENTS	23
自动倒送料部件	
15. THREAD FEEDER COMPONENS	24
挑线部件	
18. THREAD RELEASE SOLENOID COMPONENTS	25
送线及倒缝按钮部件	
19. LUBRICATION COMPONENTS	26
油路部件	
20. WIPER MECHANISM COMPONENTS	28
拨线部件	
21. UNDER COVER COMPONENTS	30
膝提部件	
22. THREAD STAND COMPONENTS	32
线架部件	
23. ELECTRIC CABINET TRANSMISSION COMPONENTS	33
电控箱部件	
27. ACCESSORIES PART COMPONENTS	34
附件	

1. 机体部分(1)

FRAME&MISCELLANEOUS COVER COPONENTS(1)

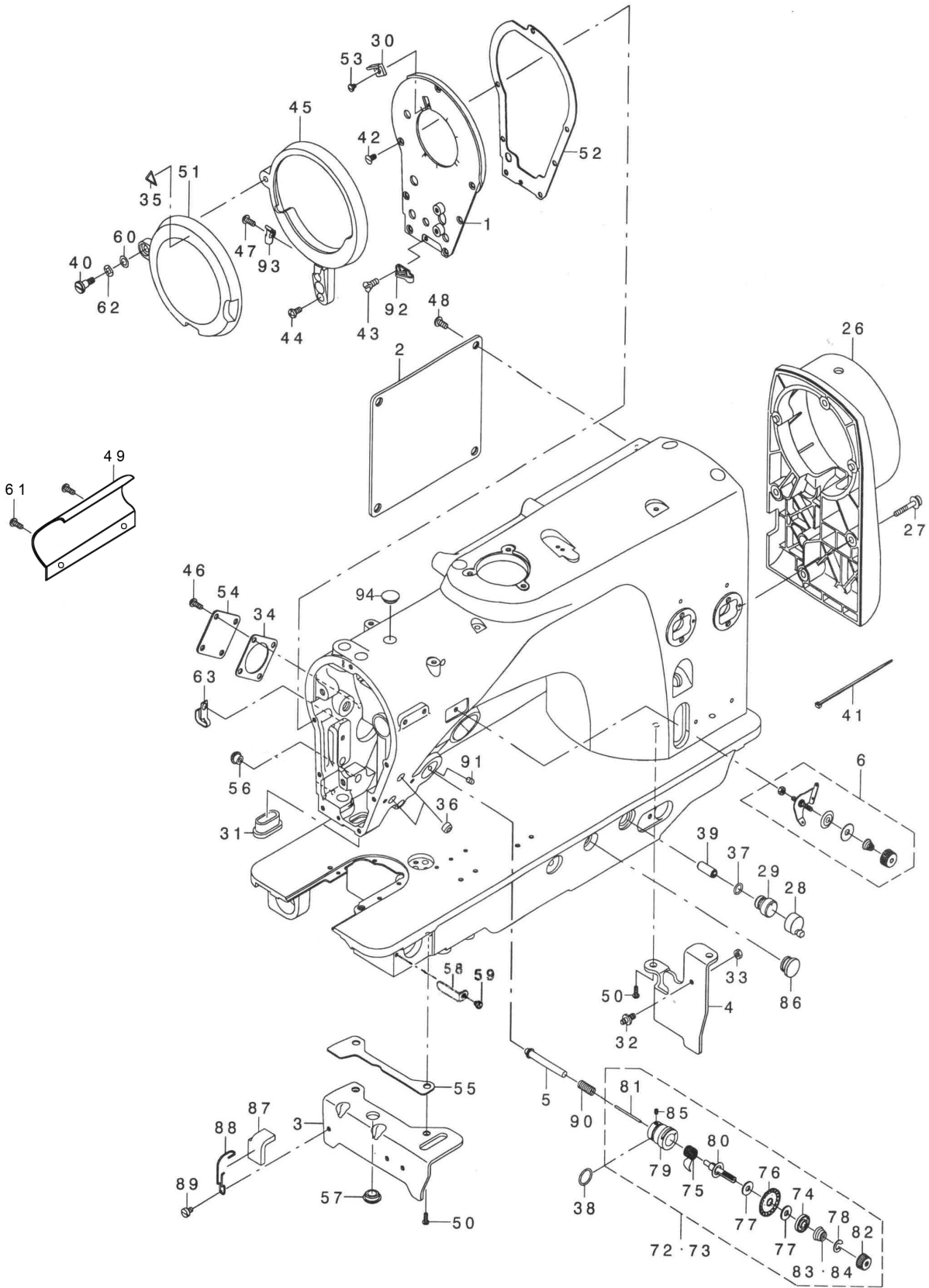

序号REF. NO.	图号 PART NO.	名称	NAME	用量AMT. REQ.
01-01	235-00978	面板组件	FACE PLATE COMPL.	1
01-02	235-26205	后盖板	SIDE PLATE	1
01-03	400-03586	前支脚	BED SUPPORT PLATE A	1
01-04	235-26403	后支脚	BED SUPPORT PLATE B	1
01-05	400-11123	松线杆	THREAD RELEASE AUXILIARY PIN	1
01-06	225-28764	中过线器组件	PRE-TENSION CONTROLLER ASM.	1
01-26	236-00604	后罩	PULLEY COVER	1
01-27	03 SL-6052592-TN	后罩螺钉	SCREW	4
01-28	236-01305	橡胶盖	ARD-DISCHARGING CAP	1
01-29	236-29900	透气阀	AIR-DISCHARGING	1
01-30	100-01709	面板刀片	TAKE-UP THREAD CUTTER	1
01-31	100-00206	摆动架槽框	ARM OIL SHIELD	1
01-32	137-47308	复位螺钉	SCREW	1
01-33	NS-6110350-SP	复位螺母	NUT	1
01-34	225-01704	密封垫片	BOBBIN LEVER	1
01-35	CM-3002000-01	警告牌	RING	1
01-36	GPR-01015000	油塞	DRIVING STOPPER RUBBER	2
01-37	RO-0801502-00	透气阀O形圈	RUBBER RING	1
01-38	RO-1331701-00	夹线器O形圈	RUBBER RING	1
01-39	PS-0800202-KH	透气阀弹簧销	CABLE BAND	1
01-40	SD-0640751-SP	护盖罩窗螺钉	HINGE SCREW	1
01-41	EA-9500B01-00	电线自锁夹	CABLE BAND	1
01-42	SS-1110840-SP	面板螺钉	SCREW	7
01-43	SS-1110840-SP	导线架螺钉	SCREW	1
01-44	SS-4110915-SP	护盖螺钉	PRE-TENSION CONTROLLER ASM.	2
01-45	263-05102	挑线盘防护盖	BALANCE COVER BASE	1
01-46	SS-4121015-SP	螺钉	SCREW	4
01-47	SS-4120615-SP	护盖弹簧片螺钉	SCREW	1
01-48	235-28607	后盖板螺钉	SCREW	3
01-49		电线压盖	CONNECTING ROD	3
01-50	225-29481	前支脚螺钉	SCREW	1
01-51	225-29473	挑线盘防护罩组件	BALANCE COVER	1
01-52	83214-047-000	面板垫	FACE PLATE PACKING	2
01-53	110-93606	面板刀片螺钉	SCREW	1
01-54	110-72402	油窗板	OIL BLOCK	1
01-55	NS-6110310-SP	垫片	NUT	1
01-56	400-23286	摆动架销油塞	RUBBER PLUG	1
01-57	SS-6090620-TP	油塞	SCREW	2
01-58		铜塞固定板	GEAR BOX CAP PRESSER	3
01-59		铜塞固定板螺钉	SCREW	2
01-60	EA-9500B02-00	护盖罩窗垫片	WASHER	1
01-61	SM-4030501-SN	螺钉	SCREW	1
01-62	235-39901	护盖罩窗弹簧片	WAVED WASHER	1
01-63	SS-4120615-SP	小线夹	UPPER SHAFT FRONT METAL OIL WIRE HOLDER	1
01-71	HK-0346100-60	释放圈	HOOSING	1
01-72	EA-9500801-60	夹线器组件	THREAD TENSION ASM.	1
01-73	SM-4021201-SC	夹线器组件	THREAD TENSION ASM.	2
01-74	SS-4120915-SP	松线板	TENSION DISC HOLDER	2
01-75	225-36502	挑线簧	TAKE-UP SPRING	1
01-76	01 229-58300	夹线板组件	THREAD TENSION DISK COMPL.	1
01-77	02 225-02504	夹线板组件	THREAD TENSION DISK COMPL.	1
01-78	225-02702	夹线螺母制动垫圈	ROTATION STOPPER	1
01-79	05 400-06012	夹线器座组件	THREAD TENSION ROD BASE ASM.	1
01-80	06 400-06013	夹线器座组件	THREAD TENSION ROD COMPL.	1
01-81	01 263-12504	松线钉	THREAD RELEASE PIN	1
01-82	04 225-04104	夹线螺母	THREAD TENSION BUT	1
01-83	229-02605	夹线簧	TENSION SPRING	1
01-84	110-43601	夹线簧	TENSION SPRING	1
01-85	RO-1952401-00	夹线螺钉紧固螺钉	SCREW	1
01-86	SS-1110840-SP	橡皮塞	PLUG	2
01-87	SS-7090410-SP	毛毡	SCREW	1
01-88	SS-7110540-SP	压簧	SCREW	2
01-89	236-04705	螺钉	MAGNET	1
01-90	119-34207	松线杆复位弹簧	E-RING	1
01-91	ST-4040821-SS	夹线器紧固螺钉	SCREW	1
01-92		导线架	SPRING GUARD	1
01-93		护盖弹簧片	SPRING	1
01-94		顶油塞	RUBBER PLUG	1

2. 机体部分(2)

FRAME&MISCELLANEOUS COVER COPONENTS(2)

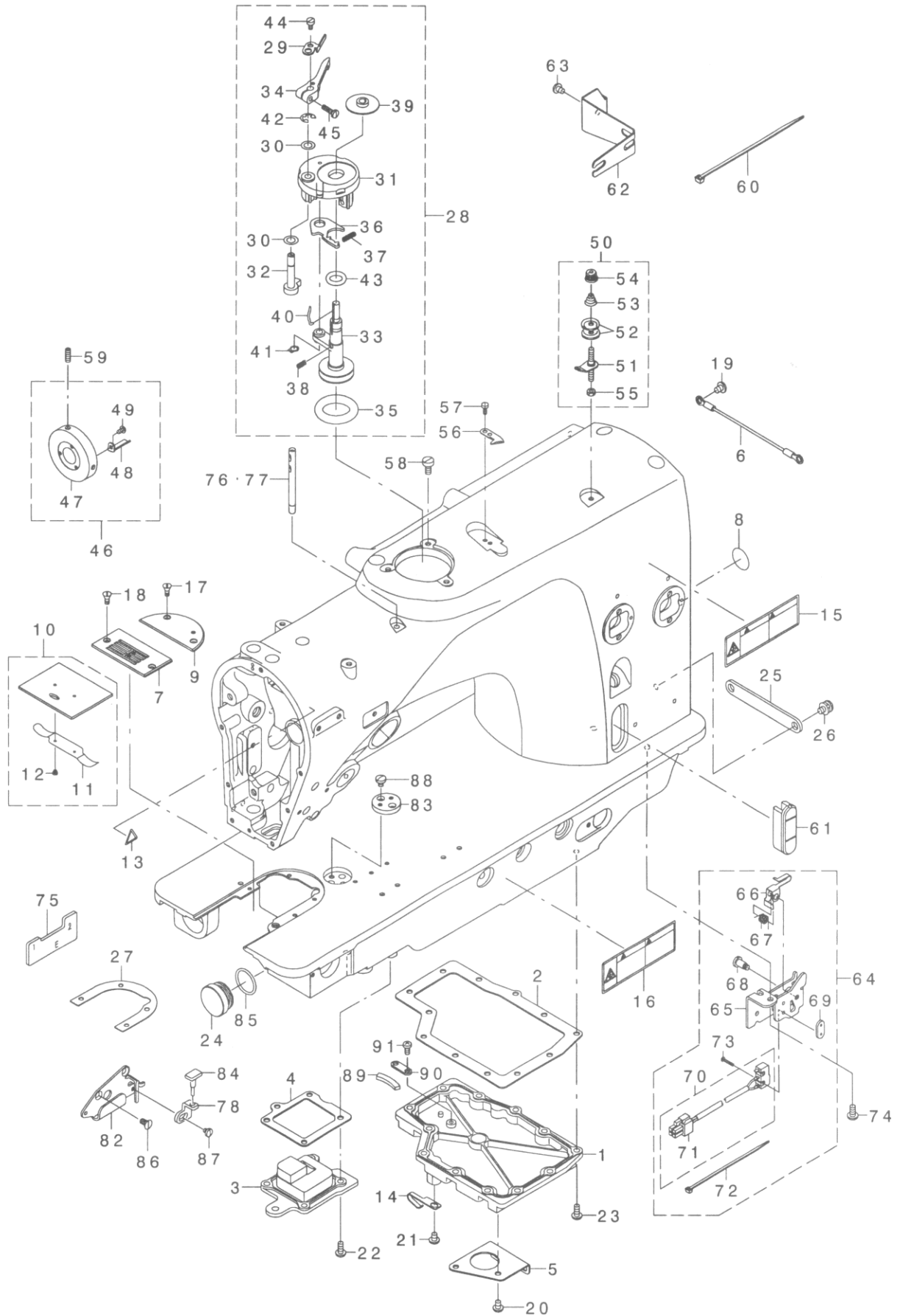

序号REF. NO.	图号 PART NO.	名称	NAME	用量AMT. REQ
02-01	235-00978	油箱盖	GEAR BOX (LARGE) COVER	1
02-02	235-26205	油箱盖垫	GEAR BOX (LARGE) PACKING	1
02-03	400-03586	旋梭齿轮箱盖	GEAR BOX (SMALL) COVER	1
02-04	235-26403	旋梭齿轮箱盖垫	GEAR BOX (SMALL) PACKING	1
02-05	400-11123	油箱大有线架	PIPE GUIDE PLATE	1
02-06	225-28764	中过线器组件	PRE-TENSION CONTROLLER ASM.	1
02-07	02 M6095-350-CAA	针板	NEEDLE PLATE	1
02-08	03 M6096-350-CAL	接地线标识	GROUND MARK	1
02-09	02 M6096-351-CAF	针板内盖板	BED PLATE	1
02-10	03 M6096-352-CAF	刀架底板组件	BED SLIDE ASM.	1
02-11	04 400-03625	刀架底板垫片	BED SLIDE SPRING	1
02-12	04 400-03626	螺钉	SCREW	1
02-13	05 400-03623	警示牌	WARNING	1
02-14	05 400-03624	油箱小油线架	LUBRIVATING OIL WICK STOPPER	1
02-15	07 M6100-350-CAA	安全提示牌	SAFETY LABEL. (SMALL)	1
02-16	08 M6097-350-CAA	安全提示牌	SAFETY LABEL. (SMALL)	1
02-17	09 400-03627	针板内盖板螺钉	SCREW	1
02-18	10 M6099-350-CAF	针板螺钉	SCREW	1
02-19	10 M6099-350-CAL	螺钉	SCREW	1
02-20	11 M6098-350-CAF	油箱大有线架螺钉	SCREW	1
02-21	11 M6098-350-CAA	油箱小有线架螺钉	SCREW	1
02-22	12 400-17100	旋梭齿轮箱盖螺钉	SCREW	1
02-23	13 400-17101	油箱盖螺钉	SCREW	1
02-24	12 400-17102	旋梭箱铜塞	GEAR BOX (SMALL) CAP	1
02-25	13 400-17103	电线压板	CONNECTING ROD	1
02-26	236-00604	压板滚压螺钉	SCREW	1
02-27	SL-6052592-TN	垫片	BOLT	4
02-28	236-01305	绕线器组件	BOBBIN DEVICE ASM.	1
02-29	236-29900	排气装置	AIR-DISCHARGING	1
02-30	100-01709	薄片	WASHER	1
02-31	100-00206	核心卷绕体组件	BOBBIN FITTING BASIS COMPL.	1
02-32	137-47308	绕线凸轮轴	BOBBIN CAM SHAFT COMPL.	1
02-33	MS-6110350-SP	核心卷绕轴	BOBBIN WINDER SHAFT COMPL.	1
02-34	01 225-01704	垫圈	GASKET	1
02-35	CM-3002000-01	橡胶轮	RING	1
02-36	GPR-01015000	控制板	ASJUSTING PLATE	2
02-37	RO-0801502-00	复位长弹簧	SPRING	1
02-38	RO-1331701-00	复位短弹簧	PRESSUR FOOT SPRING	1
02-39	PS-0800202-KH	卷绕轴垫	CUSHION	1
02-40	SD-0640751-SP	核心弹簧	LATCH SPRING	1
02-41	EA-9500801-00	绕线器摆动板轴挡圈	RETAINING RING	1
02-42	SS-1110840-SP	绕线器绕线凸轮轴挡圈	E-RING	7
02-43	SS-2090710-TP	卷线轴O型圈	RUBBER RING	1
02-44	SS-4110915-SP	螺钉	SCREW	2
02-45	263-05102	平衡盖底座	BALANCE COVER BASE1	1
02-46	SS-4121015-SP	绕线器主动轮组件	BOBBIN DRIVING WHEEL ASM.	4
02-47	SS-4120615-SP	绕线器主动轮	BOBBIN DRIVING WHEEL	1
02-48	SS-4121015-SP	主动轮支脚	BOBBIN DRIVING WHEEL BLADE	4
02-49	SS-4121015-SP	支脚螺钉	SCREW	1
02-50	SS-4150915-SP	绕线夹线器组件	BOBBIN THREAD TENSION ASM.	4
02-51	225-02108	中过线板组件	BOBBIN THREAD TENSION DISC	1
02-52	235-27401	夹线板	BOBBIN WINDER TENSION DISC	1
02-53	SS-7080410-SP	夹线簧	THREAD TENSION SPRING	1
02-54	225-01605	塑料夹线螺母	THREAD TENSION NUT	1
02-55	400-03588	夹线螺母	NUT	1
02-56	TA-0800504-RO	绕线切刀	THREAD CUTTER	1
02-57	TA-1250406-RO	切刀螺钉	SCREW	1
02-58	TA-1250406-RO	绕线器螺钉	SCREW	3
02-59	WP-0501016-SD	绕线轮紧固螺钉	SCREW	1
02-60	WP-0651056-SD	电线自锁夹	CABLE BAND	1
02-61	WS-0510002-KP	油标窗	OIL SIGHT WINDOW	1
02-62	WZ-0641510-KD	油线架	HEAD LUBRICATION PIPE STOPPER	1
02-63	400-22407	油线架螺钉	SCREW	1
02-64	D2112-555-B00	安全开关组件	SAFETY SWITCH ASM.	2
02-65	225-29002	开关架	SAFETY SWITCH BASE	1
02-66	225-29101	开关驱动杆	SAFETY SWITCH ARM	1
02-67	225-29200	开关弹簧	SAFETY SWITCH SPRING	1
02-68	SS-4110915-SP	开关驱动轴	SAFETY SWITCH ARM SHAFT	2
02-69	SS-6090540-SP	开关夹紧板	SAFETY SWITCH STOPPER PLATE	1
02-70	SS-6580752-TP	安全开关	SAFETY SWITCH CORD ASM.	2
02-71	WP-0330500-OE	安全开关	SAFETY SWITCH CORD	2
02-72	400-03633	电线自锁夹	CABLE BAND	1
02-73	400-03634	夹紧板螺钉	SCREW	1
02-74	100-06005	安全开关螺钉	SCREW	1
02-75	235-38309	计量规	TIMING GAUGE E	1
02-76	225-47557	两眼过线柱	THREAD TENSION T COMPL.	1
02-77	225-28509	两眼过线柱	SAFETY SWITCH ARM	4
02-78	229-21407	挑线簧定位板	ROTATION STOPPER	1
02-82	236-26005	过线板	BANLANCE THREAD GUIDE A	1
02-83	B3121-352-000	限位挡板	RULER STOP SEAT	1
02-84	B3129-012-A00	挑线簧定位橡胶	RUBBER STOPPER	1
02-85	SS-8090670-SP	铜塞O型圈	RING	1
02-86	TA-1250705-RO	过线板螺钉	SCREW	2
02-87	400-08934	挑线簧定位板螺钉	SCREW	1
02-88	400-08935	限位挡板螺钉	SCREW	2
02-89	SS-6110610-TP	磁铁	MAGNET	1
02-90	229-20409	磁铁压板	THREAD TAKE-UP COVER WASHER	1
02-91	SS-8110750-SP	螺钉	SCREW	1

3. 挑线刺布部件

MAIN SHAFT & THREAD TAKE-UP & NEEDLE BAR COMPONENTS

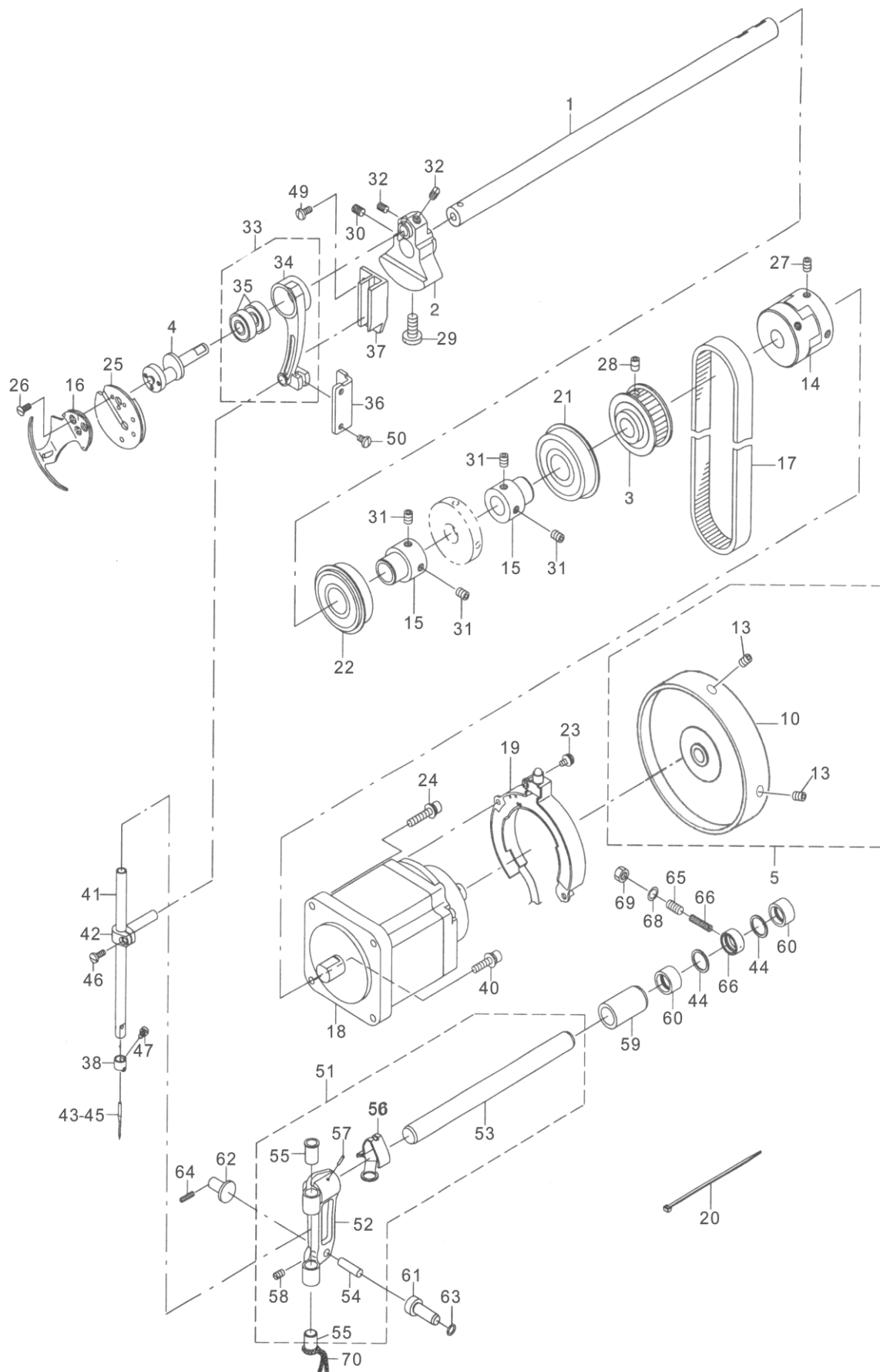

序号REF. NO.	图号 PART NO.	名称	NAME	用量AMT. REQ.
03-01	235-27906	上轴	UPPER SHAFT	1
03-02	400-10324	针杆曲柄	COUNTER WEIGHT	1
03-03	235-28003	上轴带轮	UPPER SHAFT SPROCKET	1
03-04	235-28102	挑线曲柄	NEEDLE ROD CRANK	1
03-05	235-28250	手轮部件	HAND WHEEL	1
03-010		上轮	HAND WHEEL	1
03-13		上轮紧固螺钉	SCREW	2
03-14	236-04309	联轴器组件	COUPLING	1
03-15	236-04200	上轴轴承挡圈	MAIN SHAFT SPROCKET	2
03-16	235-06208	旋转挑线盘	BALANCE V	1
03-17	225-05705	同步齿型带	TIMING BELT	1
03-18	KM-0000004-60	伺服马达	SERVO MOTOR	1
03-19	M6801-471-0A0	同步组件	SYNC ASM.	1
03-20	EA-9500B01-00	电线自锁夹	CABLE BAND	1
03-21	SB-1200008-00	上轴后轴承	BEARING	1
03-22	SB-1200009-01	上轴前轴承	BEARING	1
03-23	SL-4040881-SC	螺钉	SCREW	2
03-24	SL-6052592-TN	上轴电机外六角螺钉	BOLT	4
03-25	100-08753	旋转挑线盘座组件	TAKE-UP COUNTERWEIGHT ASM.	1
03-26	SS-1090930-SP	旋转挑线盘螺钉	SCREW	3
03-27	SM-8060812-TP	上轴传动连接块螺钉	SCREW	4
03-28	SM-8060813-TP	上轴带轮螺钉	SCREW	2
03-29	SS-7681650-TP	针杆曲柄定位螺钉	SCREW	1
03-30	SS-8680730-SP	针杆曲柄紧定螺钉	SCREW	1
03-31	SM-8060812-TP	上轴轴承挡圈螺钉	SCREW	4
03-32	SS-8660610-TP	挑线曲柄螺钉	SCREW	2
03-33	235-28755	针杆连杆组件	NEEDLE ROD CRANK ROD ASM.	1
03-34	235-28706	针杆连杆	NEEDLE ROD CRANK ROD	1
03-35	SB-1080019-00	针杆连杆轴承	BUSHING	2
03-36	235-28805	小连杆导板	NEEDLE ROD CRANK ROD GUIDE	1
03-37	400-10277	针杆连接柱导轨	NEEDLE ROD HOLDER GUIDE	1
03-38	01 225-07701	针杆线勾	THREAD RACK RIGHT	1
03-40	SL-6052092-TN	螺钉	SCREW	1
03-41	400-15494	针杆	NEEDLE ROD	1
03-42	225-07305	针杆连接柱	NEEDLE ROD HOLDER	1
03-43	01 MC-2005F07-00	机针（薄料）	NEEDLE	1
03-44	235-44901	缓冲衬套	THRUST BUSH	2
03-45	01 MDP-500B1000	机针（厚料）	NEEDLE	1
03-46	SS-7090910-TP	针杆连接柱螺钉	SCREW	1
03-47	SS-7080520-SP	机针螺钉	SCREW	1
03-49	SS-7110910-TP	针杆连接柱导轨螺钉	SCREW	2
03-50	SS-7110910-TP	小连杆导板螺钉	SCREW	2
03-51	235-29159	针杆摆动架组件	NEEDLE ROD SUPPORT BASE ASM.	1
03-52	235-29100	针杆摆动架	NEEDLE ROD SUPPORTBASE	1
03-53	235-29209	针杆摆动架轴	NEEDLE ROD SUPPORT BASE SHAFT	1
03-54	235-29308	针杆摆动架销	SUPPORT BASE GUIDE SHAFT	1
03-55	235-29506	针杆轴套	NEEDLE ROD METAL	2
03-56	235-29407	摆动架毛毡	SPRING PIN	1
03-57	PS-0400222-KO	针杆摆动架开后销	SPRING PIN	1
03-58	SS-8120740-SP	针杆摆动架销螺钉	SCREW	1
03-59	400-10315	针杆摆动架轴套	SUPPORT BASE SHAFT FRONT METAL	1
03-60	235-31114	摆动架后外套	SUPPORT BASE SHAFT BEAR METAL	2
03-61	400-10297	摆动架右定位销	SUPPORT BASE GUIDE PIN A	1
03-62	400-10296	摆动架左定位销	SUPPORT BASE GUIDE PIN B	1
03-63	RO-0371801-00	摆动架右定位销O型圈	RUBBER RING	1
03-64	SS-8151230-SP	摆动架左定位销螺钉	SCREW	1
03-65	SM-8061212-TP	摆动架后中套螺钉	SCREW	1
03-66	400-8061212-TP	摆动架后中套	METAL B	1
03-67	400-10322	摆动架后中套弹簧	SPRING	1
03-68	WP-0720516-SD	垫片	PLAIN WASHER	1
03-69	NM-6060001-SC	摆动架后中套锁紧螺帽	NUT M6	1
03-70	CQ-2020000-00	油线	OIL WICK	0.15

4. 摆针部件

NEEDLE VIBRATOR COMPONENTS

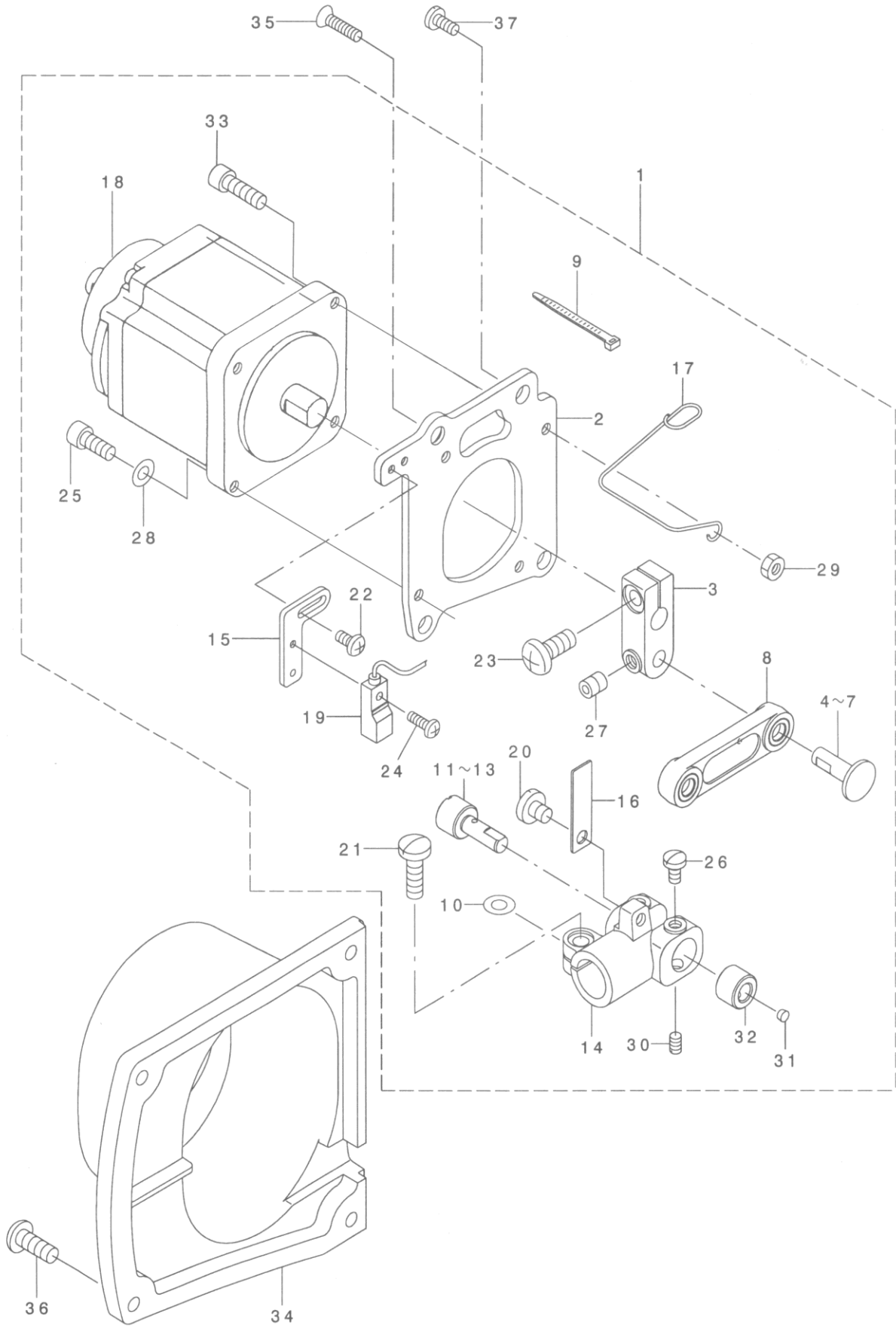

序号REF. NO.	图号 PART NO.	名称	NAME	用量AMT. REQ.
04-01	400-08370	步进电机安装组件	NEEDLE VIBRATOR UNIT	1
04-02	235-30009	步进电机安装板	NEEDLE VIBRATOR UNIT BASIS	1
04-03	400-10278	摆动架驱动块	MOTOR LINK	1
04-04	01 235-44109	摆动架连杆销	NEEDLE VIBRATOR JUNCTION ROD	1
04-05	01 235-44208	摆动架连杆销	NEEDLE VIBRATOR JUNCTION ROD	1
04-06	01 235-44307	摆动架连杆销	NEEDLE VIBRATOR JUNCTION ROD	1
04-07	01 235-44802	摆动架连杆销	NEEDLE VIBRATOR JUNCTION ROD	1
04-08	400-08169	摆动架连杆组件	SHAFT CONNECTION LINK ASM.	1
04-09	EA-9500B01-00	电线自锁夹	CABLE BAND	2
04-10	WP-0520656-SA	摆动架连接座螺钉垫片	WASHER	1
04-11	01 400-08119	摆动架驱动连杆	JUNCTION SHAFT A	1
04-12	01 400-08120	连接轴	JUNCTION SHAFT B	1
04-13	01 400-08121	连接轴	JUNCTION SHAFT C	1
04-14	400-08118	摆动架连接座	SUPPORT BASE SHAFT CONNECTION	1
04-15	235-30702	步进电机感应器安装板	SENSOR FITTING PLATE	1
04-16	235-30801	感应器挡板	SENSOR SLIT	1
04-17	235-31007	锁夹	CORD CLAMP	1
04-18	KM-0000003-50	步进电机	PULSE MOTOR	1
04-19	M8523-476-AA0	步进电机感应器	ZERO SENSOR A ASM.	1
04-20	SS-7110510-SP	感应器挡板螺钉	SCREW	1
04-21	SS-7121410-TP	摆动架连接座螺钉	SCREW	1
04-22	SM-4030655-SP	步进电机感应器安装板螺钉	SCREW	2
04-23	SM-4051255-SP	摆动架驱动块螺钉	SCREW	1
04-24	SM-4860801-SN	步进电机感应器螺钉	SCREW	1
04-25	SM-6041002-TP	步进电机螺钉	SCREW	3
04-26	SS-7110730-SP	摆动架连杆轴螺钉	SCREW	2
04-27	SM-8050612-TP	摆动架连杆销螺钉	SCREW	1
04-28	WP-0482016-SZ	平面垫圈	WASHER	2
04-29	NM-6040001-SN	螺母	NUT	1
04-30	SS-8090670-SP	螺钉	SCREW	1
04-31	TA-0340201-RO	塞子	PLUG	1
04-32	400-10298	摆动架连接轴	SCREW	1
04-33	SM-6041402-TP	步进电机螺钉	SCREW	1
04-34	235-30900	步进电机罩	NEEDLE VIBRATOR UNIT COVER	1
04-35	SS-1151310-TP	步进电机安装板沉头螺钉	SCREW	1
04-36	SS-4121215-SP	步进电机罩螺钉	SCREW	4
04-37	SS-7150740-SP	步进电机安装板螺钉	SCREW	3

5. 抬压脚部件

HAND LIFTER COMPONENTS

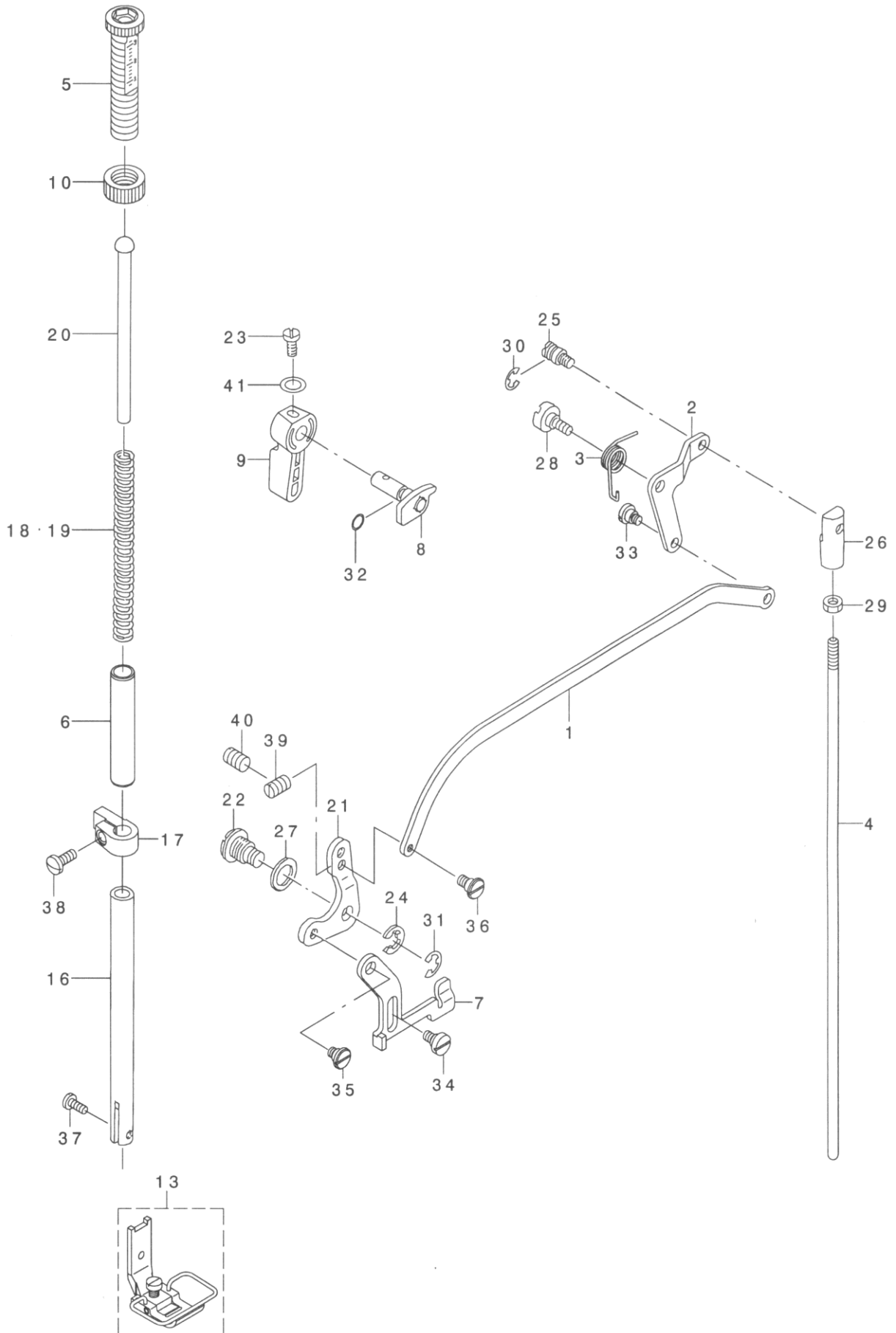

序号REF. NO.	图号 PART NO.	名称	NAME	用量AMT. REQ.
05-01	235-31304	抬压脚拉杆	KNEE LIFTING SIDE ROD LINK	1
05-02	235-31403	抬压脚后杠杆	KNEE LIFTING LINK SPRING	1
05-03	235-31502	抬压脚后杠杆复位弹簧	KNEE LIFTING LINK SPRING	1
05-04	400-03601	顶杆	KNEE LIFTING JUNCTION ROD	1
05-05	236-09209	调压螺钉	PRESSER SPRING REGULATOR	1
05-06	236-09001	压脚轴套	BUSHING	1
05-07	263-08007	抬压脚升降板	LIFTING LEVER	1
05-08	263-07850	压脚扳手组件	HAND LIFTER CAM COMPL.	1
05-09	229-07802	压脚扳手	HAND LIFTER	1
05-10	229-07604	调节螺母	NUT	1
05-13	03 225-80864	活压脚组件	PRESSER FOOT ASM.	1
05-16	100-22010	压杆	PRESSER BAR GUIDE BRACKET	1
05-17	263-02901	压杆导架	SCREW	1
05-18	05 B1505-227-T00-A	调压弹簧	PRESSER SPRING REGULATOR	1
05-19	05 229-07406	调压弹簧	PRESSER SPRING REGULATOR	1
05-20	229-07703	调压导杆	PRESSER GUIDE BAR	1
05-21	B1516-552-000	抬压脚前杠杆	LIFTING LEVER LINK	1
05-22	B1517-552-000	前杠杆吊紧螺钉	HINGE PIN	1
05-23	B1521-555-000	压脚扳手螺钉组件	SCREW	1
05-24	B1523-226-000	螺纹销开口挡圈	SNAP RING	1
05-25	B3416-552-000	杠杆接口螺钉	CONNECTING ROD HINGE SCRE	1
05-26	B3416-555-000	抬压脚顶杆接头	SWIVEL	1
05-27	B3431-581-000	提升杆垫圈	LIFTING LEVER GASKET	1
05-28	GAK-33041000	抬压脚后杠杆螺钉	KNEE LIFTING LINK STEP-SCREW	1
05-29	NS-6620310-SP	顶杆螺母	NUT	1
05-30	RE-0500000-K0	杠杆机头卡簧	E-RING	1
05-31	RE-0600000-K0	螺纹销开口挡圈	SNAP RING	1
05-32	RO-0371801-00	O型圈	RUBBER RING	1
05-33	SD-0600341-TP	抬压脚后杠杆销	HINGE SCREW	1
05-34	SD-0630275-SP	升降板下螺钉	HINGE SCREW	1
05-35	SD-0630301-SP	升降板上螺钉	HINGE SCREW	1
05-36	SD-0630371-SP	抬压脚拉杆螺钉	HINGE SCREW	1
05-37	SS-7090910-TP	压脚螺钉	SCREW	1
05-38	SS-7111110-TP	压脚导杆螺钉	PRESSER BAR GUIDE BRACKET	1
05-39	SS-8150510-TP	限位螺钉	SCREW	1
05-40	SS-8151720-SP	紧定螺钉	SCREW	1
05-41	WP-0740516-SP	垫圈	WASHER	1

6. 倒送料部件(1)
 FEED MECHANISM COMPONENTS(1)

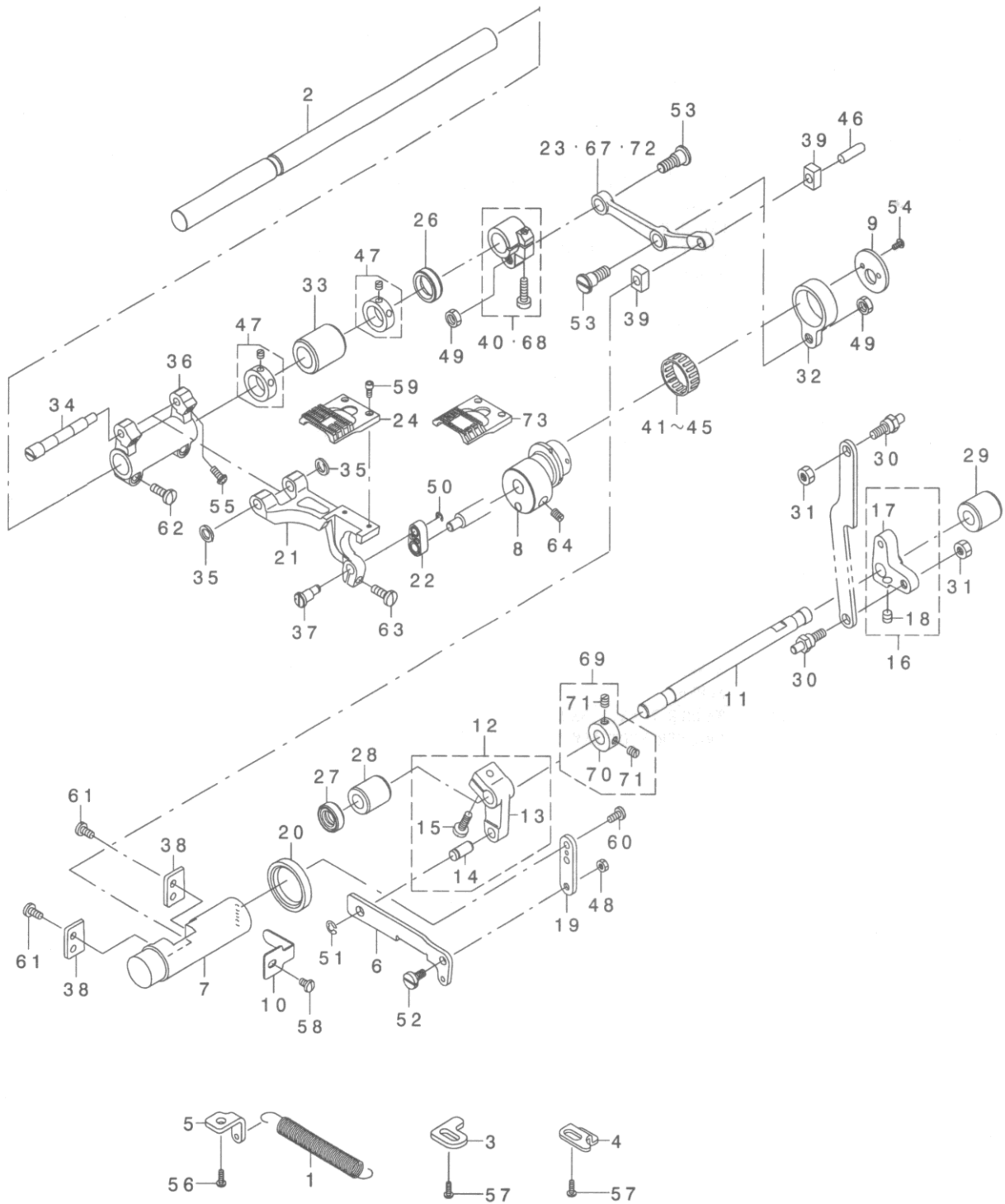

序号	REF. NO.	图号	PART NO.	名称	NAME	用量	AMT. REQ.
06-01	05	235-32500		复位弹簧	FEED ADJUSTING SPRING	1	
06-02	01	400-10311		水平送料轴	HORIZONTAL FEED SHAFT	1	
06-03	05	235-32906		限位板III	REGULATE PLATE3	1	
06-04	05	235-33003		限位板II	REGULATE PLATE2	1	
06-05	05	235-32609		复位弹簧勾	FEED SPRING RACK	1	
06-06	05	235-32807		倒送料板	FEED REVERSAL LINK	1	
06-07		400-10318		送料连接传动轴	FEED ADJUSTING	1	
06-08		235-32302		送料偏心凸轮	HORIZONTAL FEED CAM	1	
06-09		235-32401		送料偏心凸轮挡板	HORIZONTAL FEED CAM COVER	1	
06-10		235-32203		限位板I	FEED ADJUSTING PRESSER	1	
06-11	05	400-10313		倒送料轴	FEED CHANGE SHAFT	1	
06-12	05	400-10268		倒送料曲柄II部件	FEED CHANG ARM A ASM.	1	
06-13		400-10269		倒送料曲柄II	FEED CHANG ARM A	1	
06-14		229-10509		倒送料曲柄销	FEED ASJUSTING PIN	1	
06-15		SS-7121410-TP		倒送料曲柄II螺钉	SCREW	1	
06-16	05	400-10270		倒送料曲柄I	FEED CHANGE ARM B ASM.	1	
06-17		400-10271		倒送料曲柄	FEED CHANGE ARM B	1	
06-18		SS-8660612-TP		螺钉	SCREW	1	
06-19	05	235-32708		连接板	FEED ADJUSTING ARM	1	
06-20		235-32005		送料连接传动轴油封	FEED ADJUSTING OIL SEAL	1	
06-21	01	400-10263		牙架	FEED BASE SHAFT	1	
06-22		400-10264		抬牙小连杆	LINK	1	
06-23	01	400-10276		针幅调节连杆	HORIZONTAL FEED JUNCTION ROD	1	
06-24		225-81508		送料牙	FEED DOG	1	
06-26		228-88002		送料轴油封	OIL SEAL	1	
06-27	05	236-12609		倒送料轴油封	FEED CHANGING SHAFT OIL SEAL	1	
06-28	05	236-12807		倒送料轴前轴套	METAL A	1	
06-29	05	236-12906		倒送料轴后轴套	METAL B	1	
06-30	05	236-13102		倒送料曲柄I螺钉	SCREW	2	
06-31	05	NS-6150310-SP		倒送料曲柄I螺母	NUT	2	
06-32		263-00509		送料偏心凸轮套	ROD	1	
06-33		236-16709		送料轴套筒	FEED ROCKER SHAFT METAL	1	
06-34	01	100-26110		牙架销	FEED BASE SHAFT	1	
06-35	01	100-26201		牙架销垫片	SPACER	2	
06-36	01	263-03008		牙架座	FEED ROCKER	1	
06-37		235-58406		抬牙销	LINK SHAFT	1	
06-38		100-27308		送料连接传动轴挡板	PLATE A	2	
06-39		100-29619		传动轴滑块	FEED DRIVING ROCKER BLOCK	2	
06-40	01	B1608-555-0A0		送料曲柄	FEED ROCKER SHAFT CRANK ASM.	1	
06-41	03	B1609-804-A00		滚针轴承	BUSHING	1	
06-42	03	B1609-804-B00		滚针轴承	BUSHING	1	
06-43	03	B1609-804-C00		滚针轴承	BUSHING	1	
06-44	03	B1609-804-D01		滚针轴承	BUSHING	1	
06-45	03	B1609-804-E02		滚针轴承	BUSHING	1	
06-46		B1653-470-000		传动连杆销	PIN	1	
06-47		CS-1470710-SH		送料轴挡圈	THRUST COLLAR ASM.	2	
06-48	05	NS-6120310-SP		倒送料螺母	NUT	1	
06-49		NS-6680410-SP		传动连杆曲柄螺母	NUT	2	
06-50		RE-0300000-KO		抬牙销挡圈	E-RING	1	
06-51	05	SD-0500000-KO		倒送料板卡簧	E-RING	1	
06-52	05	SD-0600321-SP		倒送料板螺钉	HINGE SCREW	1	
06-53		SD-0900701-TP		传动连杆曲柄螺钉	SCREW	2	
06-54		SS-4080620-TP		送料偏心凸轮挡板螺钉	SCREW	2	
06-55	01	SS-4120915-SP		抬牙销紧固螺钉	SCREW	2	
06-56	05	SS-4150915-SP		复位弹簧钩螺钉	SCREW	1	
06-57	05	SS-4150915-SP		限位板I螺钉	SCREW	2	
06-58		SS-5110710-SP		限位板I螺钉	SCREW	1	
06-59		SS-6580752-TP		送料牙螺钉	SCREW	2	
06-60	05	SS-7110910-TP		倒送料板螺钉	SCREW	2	
06-61		SS-7110910-TP		送料连接传动轴螺钉	SCREW	4	
06-62		SS-7121410-TP		牙架座螺钉	SCREW	2	
06-63		SS-7121410-TP		牙架紧固螺钉	SCREW	1	
06-64		SS-8660810-TP		偏心轮紧定螺钉	SCREW	2	
06-67	02	263-03206		倒送料曲柄II	FEED CHANG ARM A	1	
06-68	02	100-27100		倒送料轴	FEED CHANGE SHAFT	1	
06-69	05	CS-100081C-SP		倒送料轴组件	THRUST COLLAR ASM.	1	
06-70	05	CS-1000811-SP		倒送料轴挡圈	THRUST COLLAR	1	
06-71	05	SS-8110520-TP		倒送料轴挡圈螺钉	SCREW	2	
06-72	04	400-11850		倒送料曲柄II	FEED CHANG ARM A	1	
06-73	04	400-18430		送料牙	FEED DOG	1	

7. 针距部件

FEED MECHANISM COMPONENTS(2)

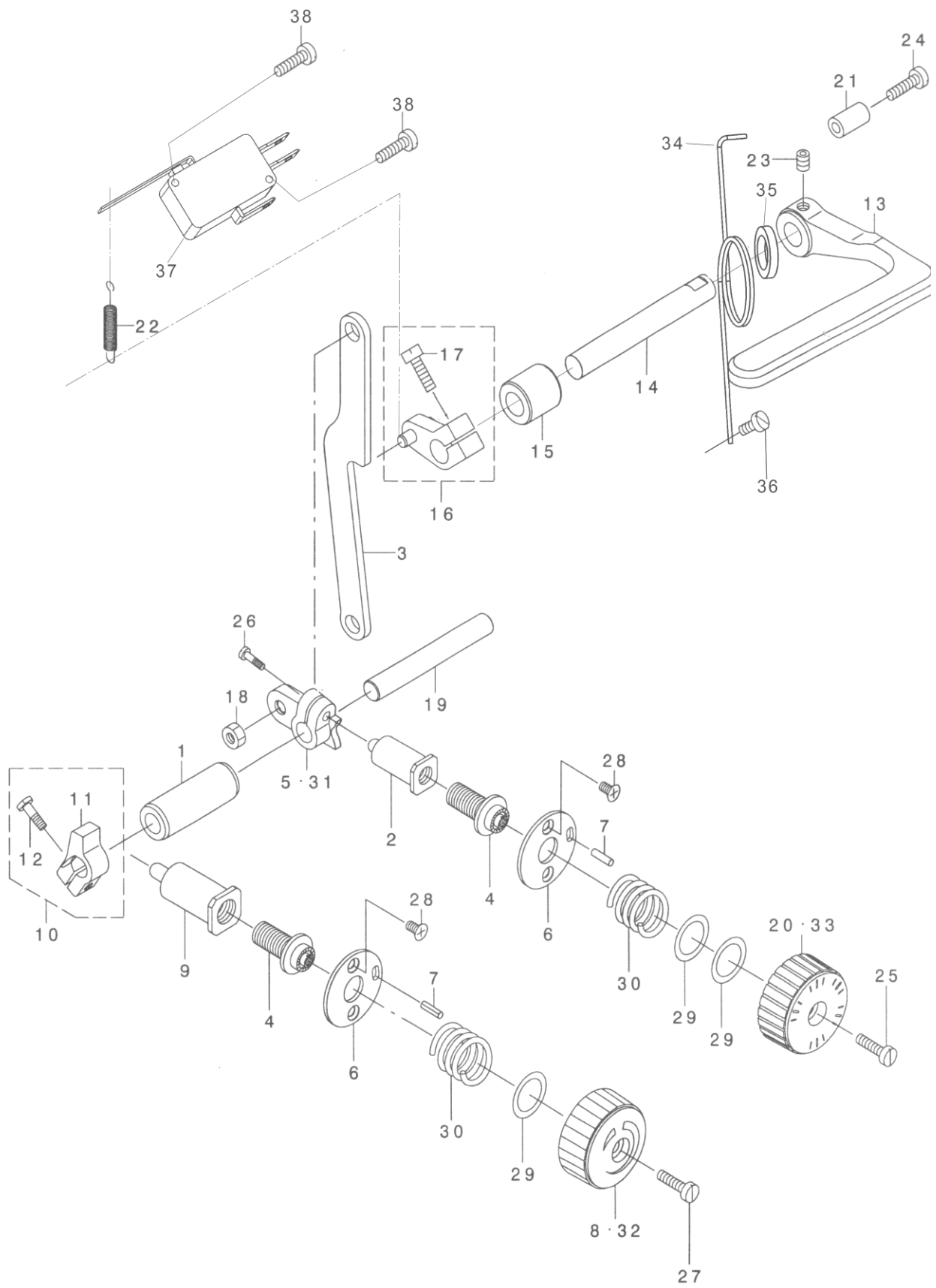

序号REF. NO.	图号 PART NO.	名称	NAME	用量AMT. REQ.
07-01	235-33706	针距座轴套	FEED ADJUSTING SHAFT METAL	1
07-02	235-33805	倒缝针距螺杆座	FEED ADJUSTING SHAFT	1
07-03	235-33409	倒缝调节杆	FEED ADJUSTING ROD	1
07-04	235-33904	针距螺杆	FEED ADJUSTING SCREW	2
07-05	400-10272	顺缝针距座	FEED BLAND CONTROLLER	1
07-06	235-34019	针距螺杆限位板	FEED ADJUSTING BASE	2
07-07	PS-0300122-KH	针距旋钮定位销	SPRING PIN	2
07-08	01 235-34407	倒缝针距旋钮	CONDENS DIAL	1
07-09	235-34308	倒缝针距螺杆套	FEED ADJUSTING SHAFT	1
07-10	235-34258	倒缝针距座组件	CONDENS STOPPER ASM.	1
07-11	235-34209	倒缝针距座	CONDENS STOPPER	1
07-12	SS-7121410-TP	针距座螺钉	SCREW	1
07-13	236-13607	倒送料扳手	FEED LEVER	1
07-14	236-13706	倒缝扳手轴	FEED LEVER SHAFT	1
07-15	236-13805	倒缝扳手轴套	FEED LEVER SHAFT METAL	1
07-16	236-13953	倒缝曲柄组件	FEED LEVER ARM ASM.	1
07-17	SS-6121620-SP	倒缝曲柄组件螺钉	SCREW	1
07-18	NS-6150310-SP	倒缝调节杆螺母	NUT	1
07-19	235-33607	针距座轴	FEED ADJUSTING SHAFT	1
07-20	01 110-71909	顺缝针距旋钮	FEED DIAL	1
07-21	111-00500	倒缝扳手定位套	REVERSE FEED LEVER STOPPER	1
07-22	113-02700	倒缝复位弹簧	SPRING	1
07-23	SM-8060812-TP	倒送料紧定螺钉	SCREW	2
07-24	SS-6121840-SP	倒缝扳手定位套螺钉	SCREW	1
07-25	SS-6121860-SP	针距旋钮螺钉	SCREW	1
07-26	SS-7121410-TP	针距座螺钉	SCREW	1
07-27	SS-6121860-SP	针距旋钮螺钉	SCREW	1
07-28	SS-1110821-TP	针距螺杆限位板螺钉	SCREW	4
07-29	SP-1651616-SD	针距旋钮波形垫圈	WAVED WASHER	3
07-30	235-34506	走向转盘弹簧	FEED DIAL SPRING	2
07-31	02 400-10273	顺缝针距座	FEED BLAND CONTROLLER	1
07-32	02 235-45007	倒缝针距旋钮	CONDENS DIAL	1
07-33	02 263-02000	顺缝针距旋钮	FEED DIAL	1
07-34		倒缝复位弹簧	SPRING	1
07-35		垫圈	WASHER	1
07-36		螺钉	SCREW	1
07-37		倒缝开关	REVERSE FEED CONTROL	1
07-38		螺钉	SCREW	2

8. 针距部件

FEED MECHANISM COMPONENTS(3)

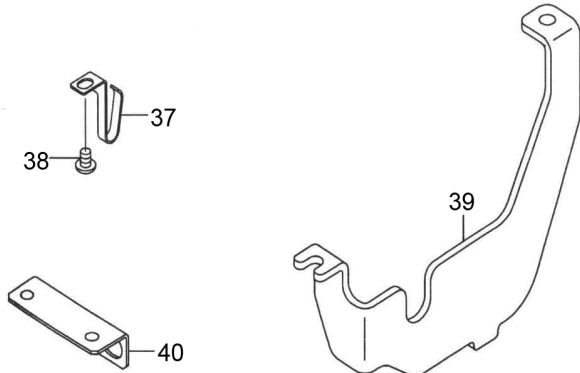
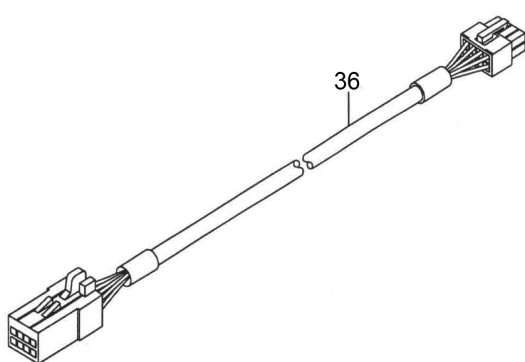
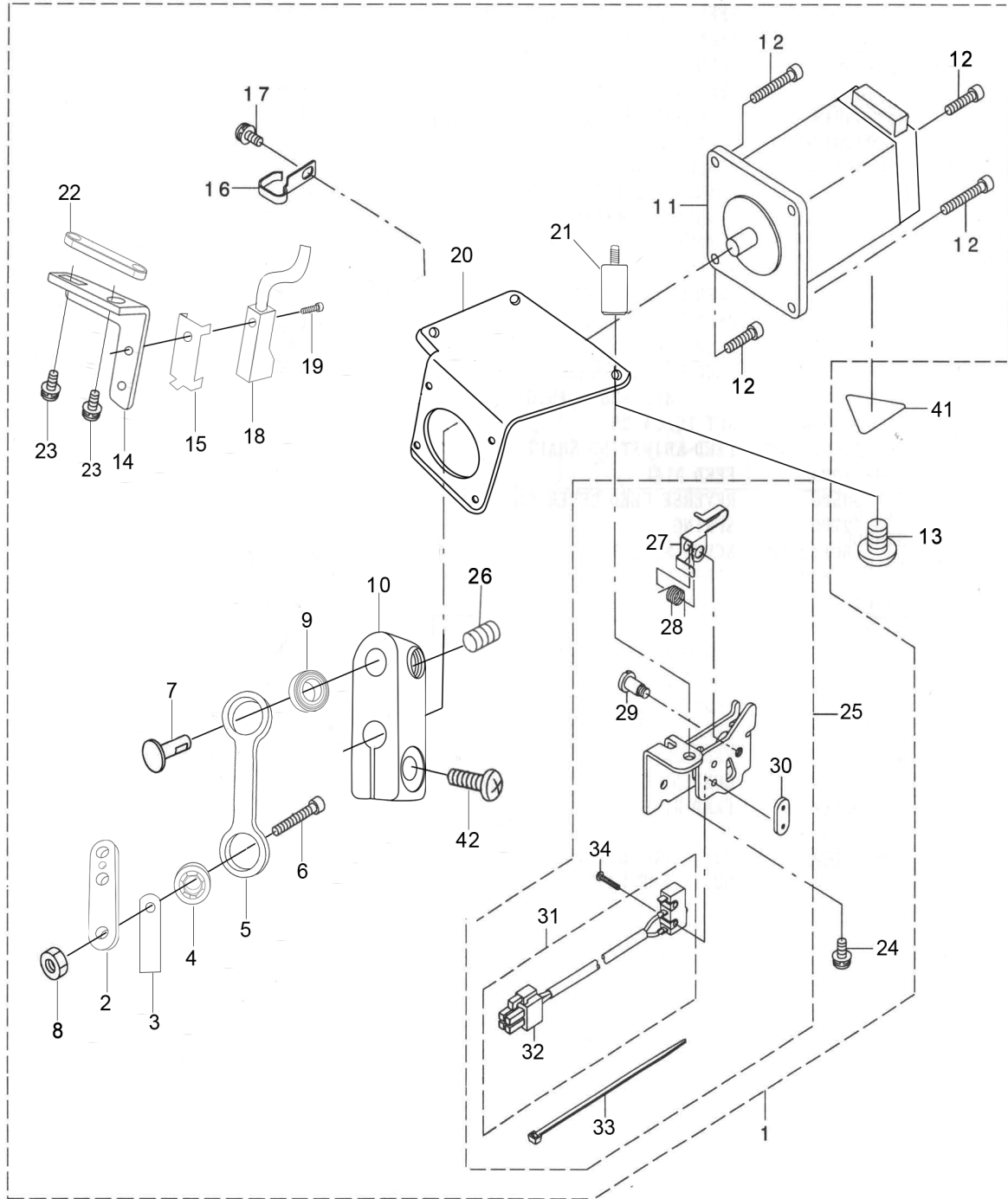

序号REF. NO.	图号 PART NO.	名称	NAME	用量AMT. REQ.
08-01	400-11931	步进电机部件	ASSY FEED PULSE MOTOR UNIT	1
08-02	400-11837	连接板	PULSE MOTOR LINK C	1
08-03	400-11840	传感链	SENSOR SLIT	1
08-04		关节轴承	SHAFT	1
08-05		步进电机连杆	PULSE MOTOR CONNECTOR	1
08-06		步进电机连杆连接螺钉	SCREW	1
08-07		步进电机送料轴销	FEED PIN	1
08-08		螺母	PULSE MOTOR CONNECTOR	1
08-09		轴承	SHAFT	1
08-10		步进马达连接块	PULSE MOTOR LINK B	1
08-11	KM-0000003-50	步进马达	PULSE MOTOR	1
08-12	SM-6042502-TP	螺钉	SCREW	4
08-13	SM-6041602-TP	螺钉	SCREW	1
08-14		倒缝步进电机感应器安装板	REVERSE PULSE MOTOR SENSOR INSTALLATION PLATE	1
08-15		感应器固定座	SENSOR HOLDER	1
08-16	400-22407	线座	CORD HOLDER	1
08-17	SL-4040892-SC	螺钉	SCREW	1
08-18	M8523-476-AA0	传感器组件	ZERO SENSOR A ASM.	1
08-19		螺钉	SCREW	1
08-20	400-11832	步进马达安装座	FEED PULSE MOTOR BASE	1
08-21		电机安装支架螺钉	MOTOR INSTALLATION SUPPORT	1
08-22		安装板垫片	WASHER	1
08-23		螺钉	SCREW	2
08-24	01 400-11833	螺钉	SCREW	1
08-25	01 235-41352	安全开关组件	SAFETY SWITCH ASM.	1
08-26		平头螺钉	SCREW	1
08-27	01 236-38109	安全开关组件	SAFETY SWITCH ARM	1
08-28	236-38208	安全开关弹簧	SAFETY SWITCH SPRING	1
08-29	236-38307	安全开关组件轴	SAFETY SWITCH ARM SHAFT	1
08-30	236-38406	安全开关螺母	SAFETY SWITCH NUT	1
08-31	235-41451	安全开关线组件	SAFETY SWITCH CORD ASM.	1
08-32	HK-0346100-60	机壳	HOUSING	1
08-33	EA-9500B01-00	电线自锁夹	CABLE BAND	1
08-34	SM-4021201-SC	螺钉	SCREW	2
08-35	SS-4151215-SP	螺钉	SCREW	3
08-36	400-17098	开关电缆组件	BTPM RELAY CABLE ASM.	1
08-37	B3508-220-000	油管固定器	OIL TUBE HOLDER	1
08-38	SS-4120615-SP	螺钉	SCREW	1
08-39	400-11841	后支板	BED SUPPORT PLATE B	1
08-40	400-11842	管导向板	PIPE GUIDE PLATE B	1
08-41	CM-3003000-03	注意标志	ATTENTION SEAL 2	1
08-42		步进马达连接块螺钉	SCREW	1

10. 下轴部件(1)

HOOK DRIVING SHAFT COMPONENTS(1)

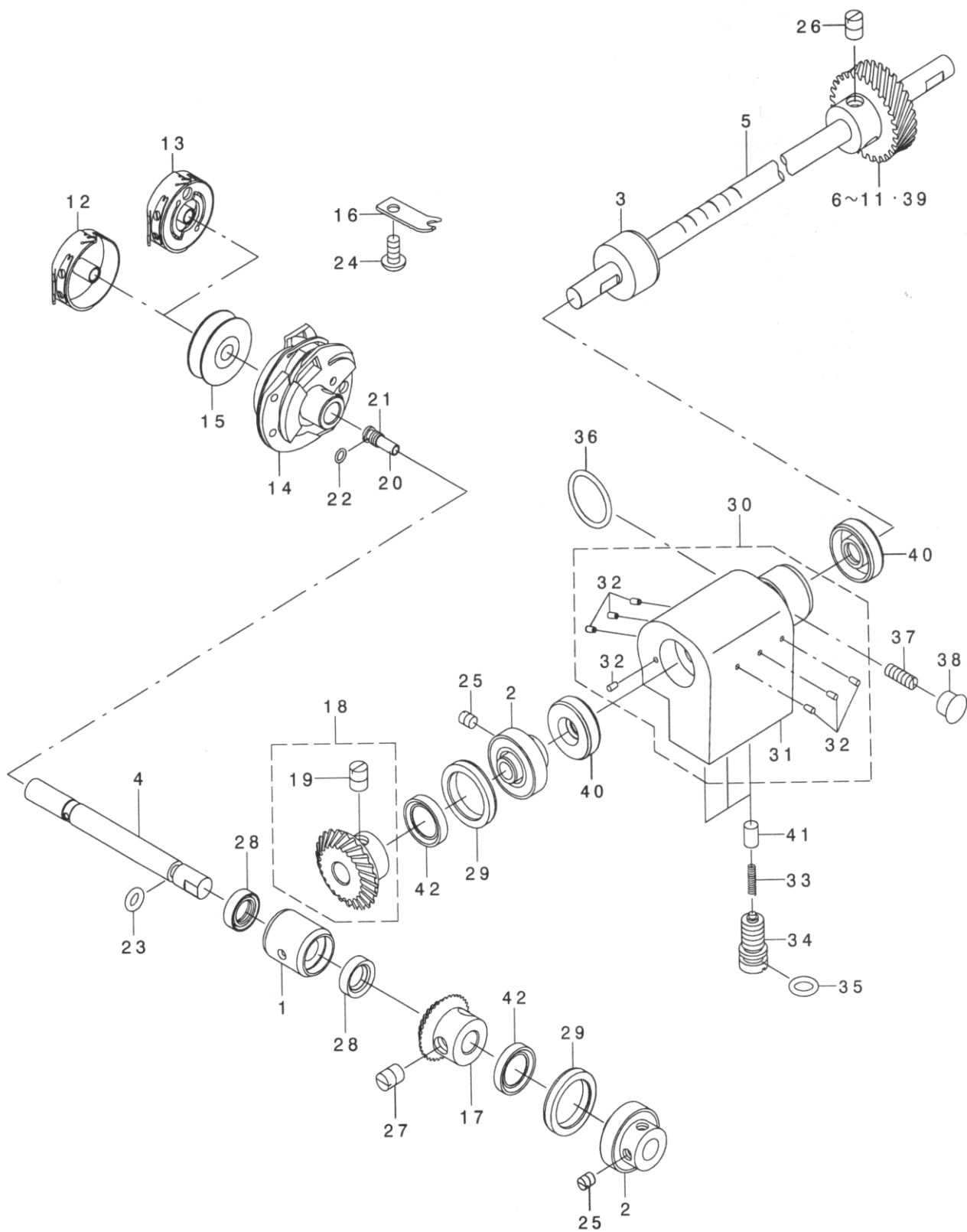

序号REF. NO.	图号 PART NO.	名称	NAME	用量AMT. REQ.
10-01	235-35107	旋梭轴轴套	HOOK SHAFT FRONT METAL	1
10-02	400-03590	旋梭轴轴承	HOOK SHAFT BEARING ASM.	2
10-03	235-35602	旋梭驱动轴后轴套	HOOK DRIVING SHAFT BEAR METAL	1
10-04	400-03592	旋梭轴	RUBBER RING	1
10-05	02 400-03567	旋梭驱动轴	HOOK DRIVING SHAFT	1
10-06	02 235-36303	旋梭驱动轴圆柱斜齿轮A	HOOK DRIVING GEAR (SMALL) A	1
10-07	02 235-36402	旋梭驱动轴圆柱斜齿轮B	HOOK DRIVING GEAR (SMALL) B	1
10-08	02 235-36501	旋梭驱动轴圆柱斜齿轮C	HOOK DRIVING GEAR (SMALL) C	1
10-09	02 235-36600	旋梭驱动轴圆柱斜齿轮D	HOOK DRIVING GEAR (SMALL) D	1
10-10	02 235-36709	旋梭驱动轴圆柱斜齿轮E	HOOK DRIVING GEAR (SMALL) E	1
10-11	02 235-36808	旋梭驱动轴圆柱斜齿轮F	HOOK DRIVING GEAR (SMALL) F	1
10-12	400-03599	梭壳	BOBBIN CASE ASM.	1
10-13	01 400-03598	梭壳	BOBBIN CASE ASM.	1
10-14	225-25877	旋梭	HOOK COMPL. V	1
10-15	225-96704	梭心	BOBBINS	1
10-16	235-03402	旋梭定位勾	INNER HOOK STOPPER	1
10-17	B1308-155-000	旋梭轴伞齿轮	HOOK GEAR	1
10-18	B1307-155-0A0	旋梭驱动轴伞齿轮	HOOK GEAR	1
10-19	SS-8660810-TP	旋梭驱动轴伞齿轮螺钉	SCREW	2
10-20	110-15906	下轴限油芯	OIL WICK 1	1
10-21	229-16506	旋梭限油螺钉	SCREW	1
10-22	R0-0360802-00	旋梭限油螺钉O型圈	RUBBER RING	1
10-23	R0-0481901-00	旋梭轴O型圈	RUBBER RING	1
10-24	SS-4110915-SP	旋梭定位勾螺钉	SCREW	1
10-25	SS-8110520-TP	旋梭驱动轴轴承挡圈螺钉	SCREW	4
10-26	SS-8660810-TP	旋梭驱动轴圆柱斜齿轮螺钉	SCREW	2
10-27	SS-8660810-TP	旋梭轴伞齿轮螺钉	SCREW	2
10-28	235-37202	旋梭轴轴套油封	HOOK SHAFT OIL SEAL	2
10-29	400-10282	油塞垫圈	OIL SEAL COLLAR	2
10-30	400-10261	油泵体	PUMP METAL ASM.	1
10-31	400-10262	油泵体	PUMP METAL ASM.	1
10-32	TA-0180401-M0	堵油螺钉	SCREW	7
10-33	236-28902	柱塞簧	RUBBER SPRING	3
10-34	236-29009	柱塞螺钉	SCREW	3
10-35	R0-0681901-00	柱塞螺钉O型圈	RUBBER RING	3
10-36	R0-1721801-00	旋梭驱动轴前轴套O型圈	RUBBER RING	1
10-37	SS-8111251-SP	旋梭驱动轴前轴套调节螺钉	SCREW	1
10-38	TA-0850604-R0	调节螺钉油塞	PLUG	1
10-39	02 235-38903	旋梭驱动轴圆柱斜齿轮	HOOK DRIVING GEAR (SMALL) E	1
10-40	228-90008	旋梭驱动轴前轴套油封	HOOK DRIVING SHAFT OIL SEA	2
10-41	236-28803	柱塞	PLUNGER	3
10-42	400-11424	齿轮箱油封	HOOK GEAR BOX OIL SEAL	2

11. 下轴部件(2)

HOOK DRIVING SHAFT COMPONENTS(2)

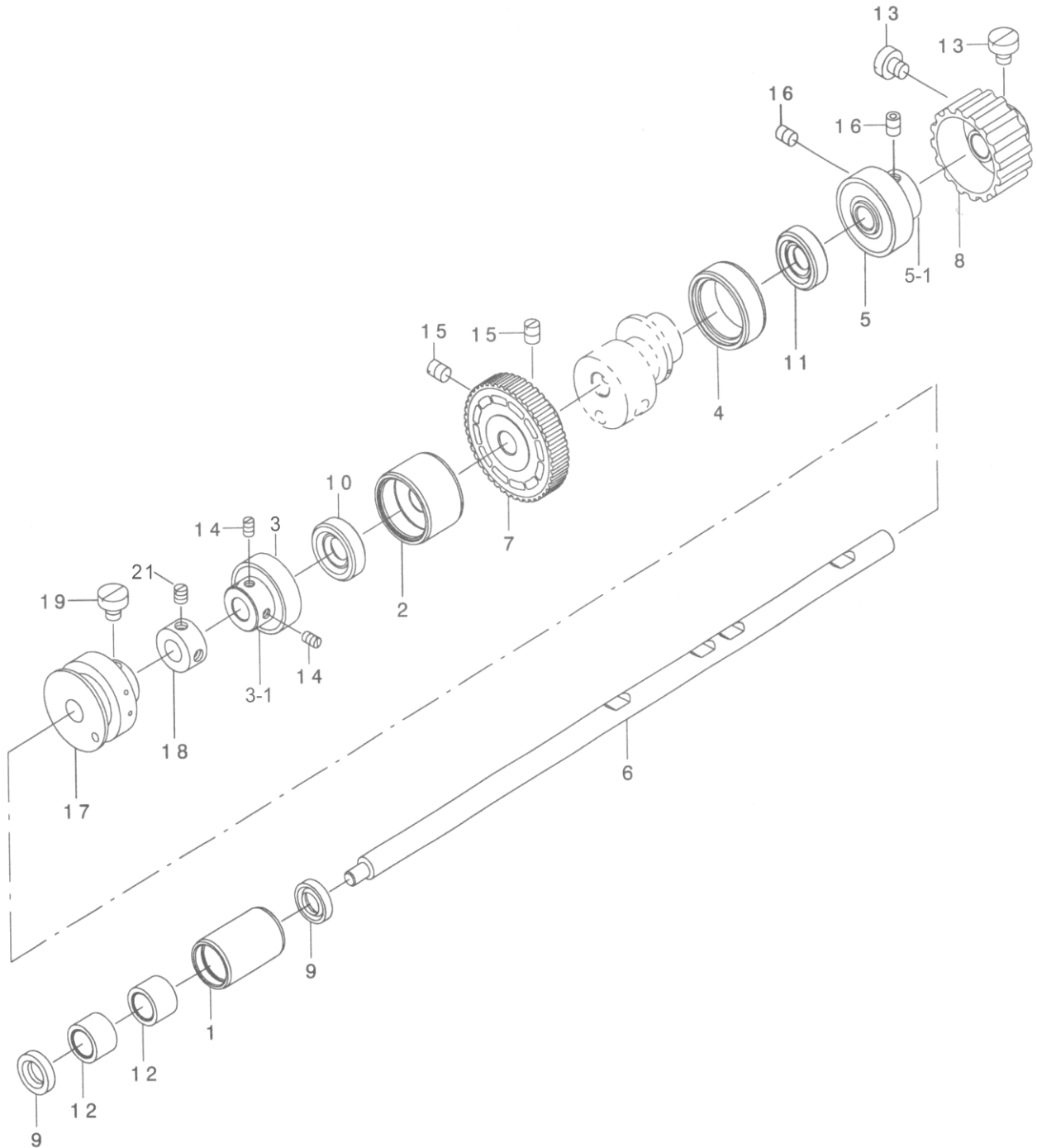

序号REF. NO.	图号 PART NO.	名称	NAME	用量AMT. REQ.
11-01	400-10316	下轴前轴套	LOWER SHAFT FRONT BEARING BUSH	1
11-02	400-10314	下轴中轴套	LOWER SHAFT INNER METAL	1
11-03	235-36055	下轴中轴承	LOWER SHAFT INNER BEARING ASM.	1
11-03-01		下轴中轴承挡圈	LOWER SHAFT INNER BEARING ASM. SHAFT	1
11-04	235-36105	下轴后轴套	LOWER SHAFT BEAR BUSH	1
11-05	235-36253	下轴后轴承	LOWER SHAFT REAR BEARING ASM.	1
11-05-01		下轴后轴承挡圈	LOWER SHAFT REAR BEARING ASM. SHAFT	1
11-06	01 235-35701	下轴	LOWER SHAFT	1
11-07	235-36907	下轴斜齿轮	HOOK DRIVING GEAR	1
11-08	235-37103	下轴同步带轮	LOWER SHAFT SPROCKET	1
11-09	B2508-704-000	下轴前轴套油封	OIL SEAL	2
11-10	G1615-880-000	下轴中轴套油封	OIL SEAL	1
11-11	G1615-880-000	下轴后轴套油封	OIL SEAL	1
11-12	SB-3100010-00	下轴前轴承	BEARING A 10	2
11-13	SS-6660710-TP	下轴带轮紧固螺钉	SCREW	2
11-14	SS-8110750-SP	下轴中轴承挡圈螺钉	SCREW	2
11-15	SS-8660810-TP	下轴斜齿轮螺钉	SCREW	2
11-16	SM-8060812-TP	下轴后轴承挡圈螺钉	SCREW	2
11-17	235-41709	剪线凸轮	THREAD TRIMMER CAM	1
11-18	CS-10081C-SP	下轴挡圈	THRUST COLLAR ASM.	1
11-19	SS-660710-TP	剪线凸轮紧固螺钉	SCREW	2

12. 切刀部件

THREAD TRIMMER MECHANISM COMPONENTS

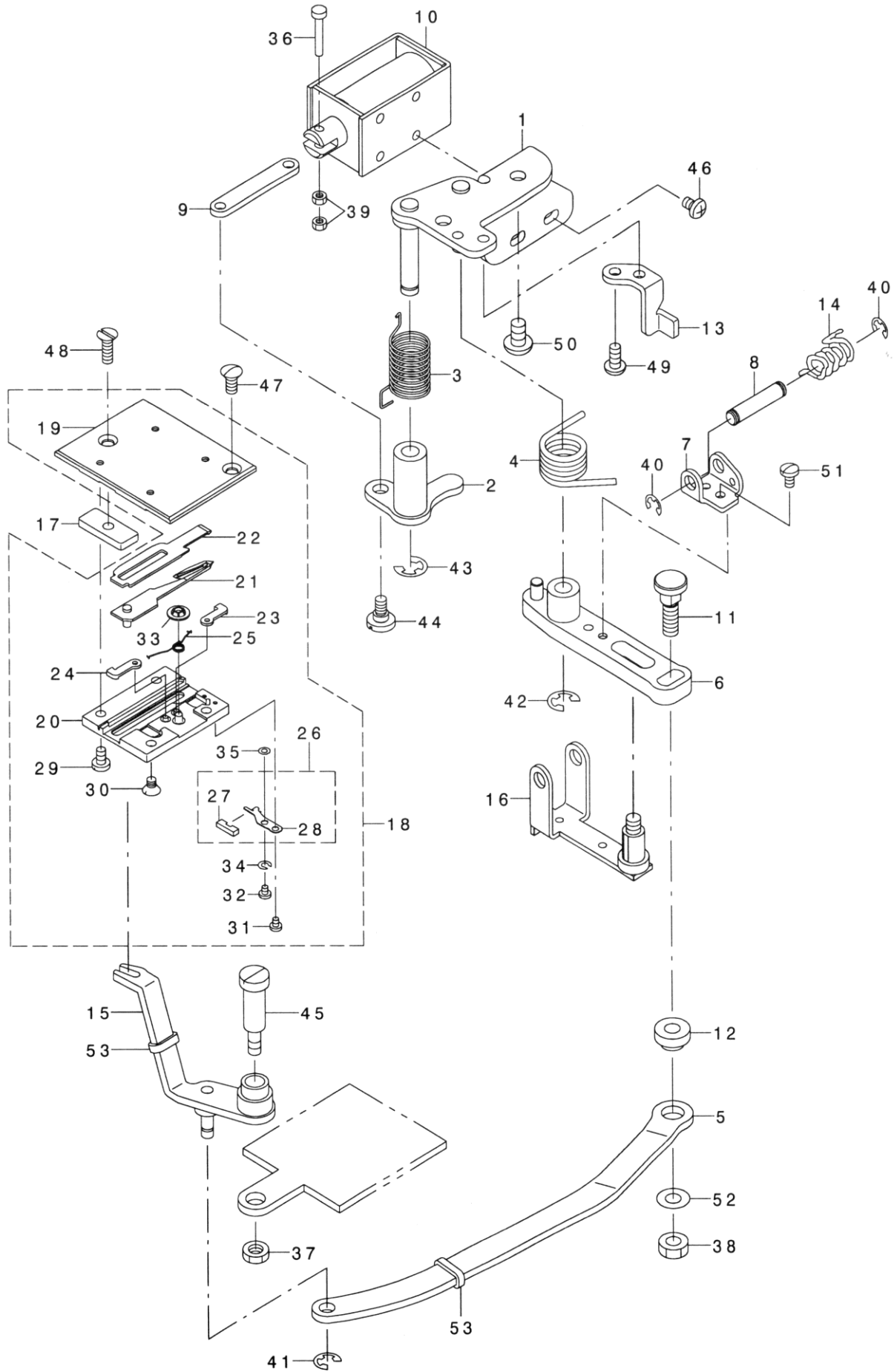

序号REF. NO.	图号 PART NO.	名称	NAME	用量AMT. REQ.
12-01	400-10290	凸轮从动器架组件	BASE PLATE ASM.	1
12-02	235-42053	驱动板组件	CLUTCH PLATE ASM.	1
12-03	235-42103	驱动板复位簧	CLUTCH RETURN SPRING	1
12-04	235-42202	驱动曲柄复位簧	KNIFE RETURN SPARING	1
12-05	235-41808	驱动脸板	MOVING KNIFE LINK	1
12-06	110-40854	剪线驱动曲柄部件	KNIFE DRIVING ARM ASM.	1
12-07	229-49002	托板支承架	ROLLER ARM SEAT	1
12-08	229-49101	托板支架销	ROLLER FULCRUM SHAFT	1
12-09	225-54505	电磁铁连板	CLUTCH LINK	1
12-10	235-42301	切线电磁铁	THREAD TRIMMER SOLENOID	1
12-11	400-10295	连接销	MOVING KNIFE LINK PIN	1
12-12	225-54802	连接销套	MOVING KNIFE LINK BASE	1
12-13	225-54901	曲柄复位挡板	DRIVING ARM STOPPER	1
12-14	225-55304	托板复位簧	ROLLER RETURN SPRING	1
12-15	225-55551	切刀驱动架组件	FORK KNIFE ASM.	1
12-16	225-55858	凸轮滚柱托板组件	ROLLER ARM ASM.	1
12-17	225-56906	夹紧板	FIXED PLATE	1
12-18	225-57458	切刀组件	KNIFE UNIT	1
12-19	225-58308	切刀板	SLIDING PLATE	1
12-20	225-58407	切刀架	KNIFE BASE	1
12-21	225-57557	下切刀组件	DRIVING KNIFE ASM.	1
12-22	225-57706	上切刀	FIXED KNIFE	1
12-23	225-57805	前刀钩	KNIFE STOPPER. RIGHT	1
12-24	225-57904	前刀钩	KNIFE STOPPER. LEFT	1
12-25	225-58209	刀钩弹簧	SPRING	1
12-26	225-58159	弹簧片组件	CLAMP PLATE ASM.	1
12-27	225-57001	毛毡	FELT	1
12-28	225-58100	切刀弹簧片	CLAMP PLATE	1
12-29	SS-7090610-SP	切刀架固定螺钉	SCREW	2
12-30	SS-1090510-SP	切刀架固定螺钉	SCREW	2
12-31	SS-7060310-SP	切刀弹簧片螺钉	SCREW	1
12-32	SS-7060310-SP	切刀弹簧片螺钉	SCREW	1
12-33	NP-2103000-00	弹簧盖帽	LOCATING SPRING WASHER	1
12-34	WS-027002-KN	螺钉弹性垫片	SPRING WASHER	1
12-35	D2056-772-B0B	螺钉垫片	WASHER	1
12-36	235-42418	电磁铁销	CLUTCH LINK PIN	1
12-37	NS-6150310-SP	切刀架螺母	NUT	1
12-38	NS-6150460-SP	切刀架螺母	NUT	1
12-39	NM-6030001-SB	切刀架螺母	NUT	2
12-40	RE-0400000-K0	托板支撑架挡圈	E-RING	2
12-41	RE-0500000-K0	切刀驱动架销挡圈	E-RING	1
12-42	RE-0600000-K0	驱动曲柄定位挡圈	E-RING	1
12-43	RE-0600000-K0	驱动板挡圈	E-RING	1
12-44	SD-0600291-TP	驱动板螺钉	SCREW	1
12-45	SD-0791503-SP	切刀驱动架螺钉	SCREW	1
12-46	SM-4040601-SC	电磁铁固定螺钉	SCREW	3
12-47	SS-2110920-TP	切刀板定位螺钉	SCREW	1
12-48	SS-2111010-TP	夹紧板螺钉	SCREW	1
12-49	SS-4110915-SP	复位挡板螺钉	SCREW	2
12-50	SS-4150915-SP	驱动器紧固螺钉	SCREW	2
12-51	SS-7090610-SP	托架支撑架螺钉	SCREW	1
12-52	WP-0621016-SH	连接销垫片	WASHER	1
12-53	229-19203	油保护橡胶	OIL PROTECTING RUBBER	2

14. 自动倒送料部件

AUTOMATIC REVERSE FEED MACHANISM COMPINENTS

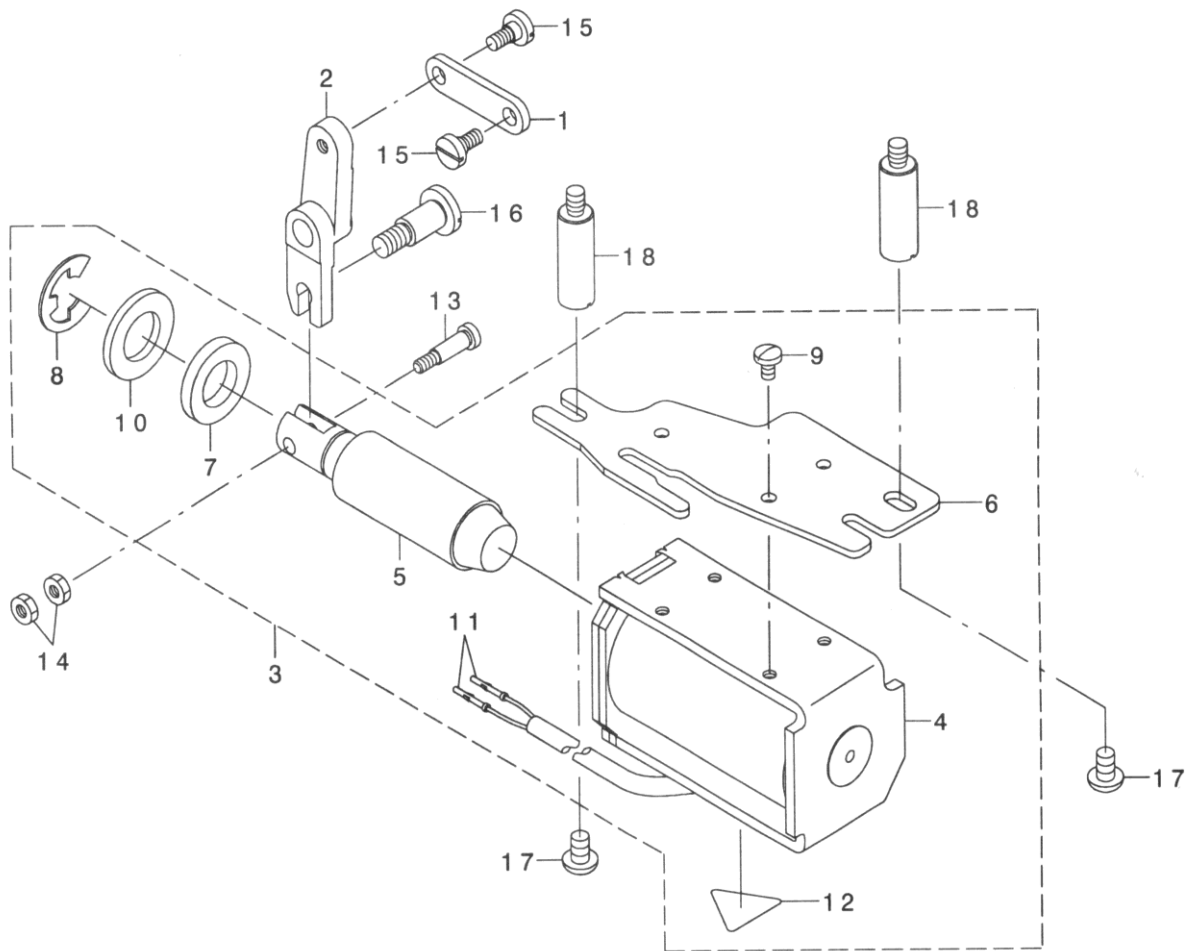

序号REF. NO.	图号 PART NO.	名称	NAME	用量AMT. REQ.
14-01	235-42509	连接板	AUTOMATIC REVERSE FEED ARM	1
14-02	400-10307	驱动轴曲柄	AUTOMATIC REVERSE FEED ARM	1
14-03	400-08596	倒缝电磁铁组件	SOLENOID BASE ASM.	1
14-04	235-42806	倒缝电磁铁主体	REVERSE FEED SOLENOID	1
14-05	236-31104	电磁铁驱动轴	REVERSE FEED SOLENOID PLUNG	1
14-06	235-42707	倒缝电磁铁固定板	REVERSE FEED SOLENOID BASE	1
14-07	D2468-555-B00	电磁铁垫片	RUBBER PLUNGER	1
14-08	RE-1200000-K0	电磁铁挡圈	E-RING	1
14-09	SS-7110740-TP	固定板螺钉	SCREW	3
14-10	WP-1703001-SC	电磁铁限位板	WASHER	1
14-11	HK-0346400-0B	接头	PIN CONTACT	2
14-12	CM-3003000-03	警示贴牌	ATTENTION SEAL 2 (3.15)	1
14-13	113-14408	电磁铁驱动轴螺钉	PLUNGER ARM PIN	1
14-14	NS-6110350-SP	电磁铁驱动轴螺母	NUT	2
14-15	SD-0600452-TP	连接板螺钉	HINGE SCREW	2
14-16	SD-0951501-SP	驱动轴曲柄螺钉	HINGE SCREW	1
14-17	SS-4150915-SP	固定板定位小螺钉	SCREW	2
14-18	400-10280	固定板定位大螺钉	BELT COVER STUD	2

15. 挑线部件 THREAD FEEDER COMPONENTS

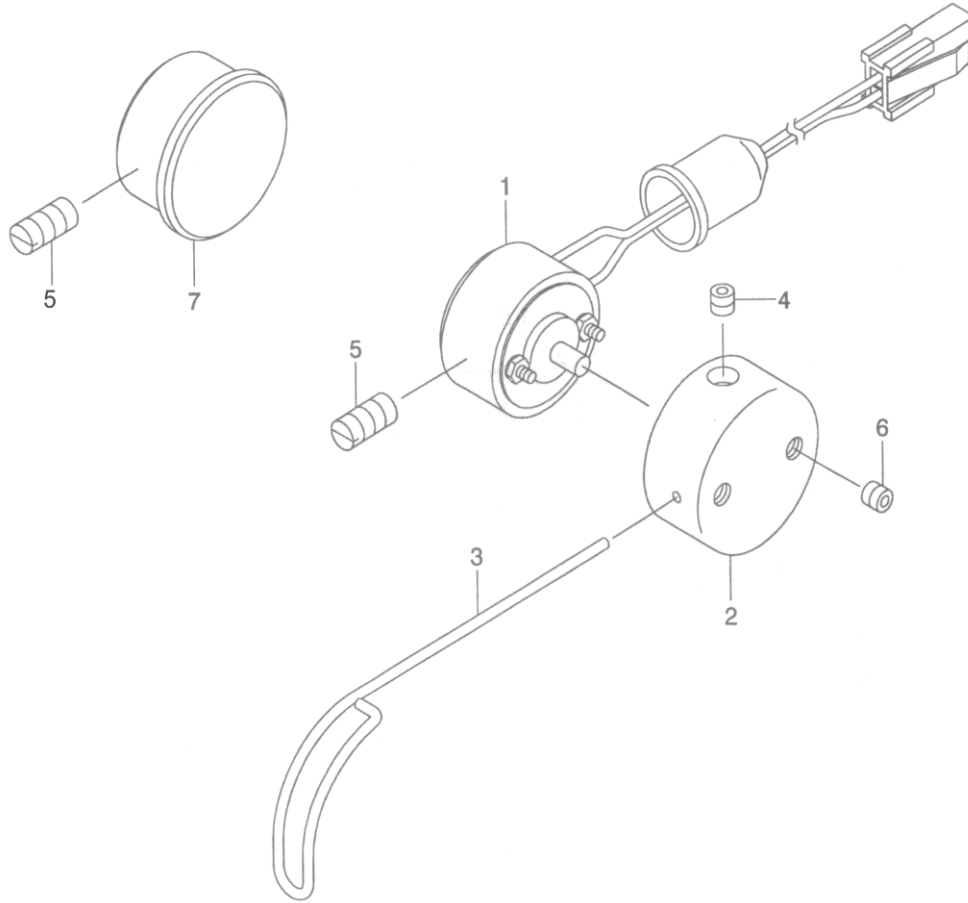

序号REF. NO.	图号 PART NO.	名称	NAME	用量AMT. REQ.
15-01	02	挑线电磁铁	FEEDER SOLENOID ASM.	1
15-02	02	挑线电磁铁罩	FEEDER WIRE FITTING BASE	1
15-03	02	挑线杆	FEEDER WIRE	1
15-04	02	电磁铁罩紧固螺钉	SCREW	1
15-05	02	挑线杆电磁铁紧固螺钉	SCREW	2
15-06	02	电磁铁罩紧固螺钉	SCREW	2
15-07	01	底盖	FEEDER FITTING BASE COVER	1

18. 送线及倒缝按钮部件

THREAD RELEASE SOLENOID COMPONENTS

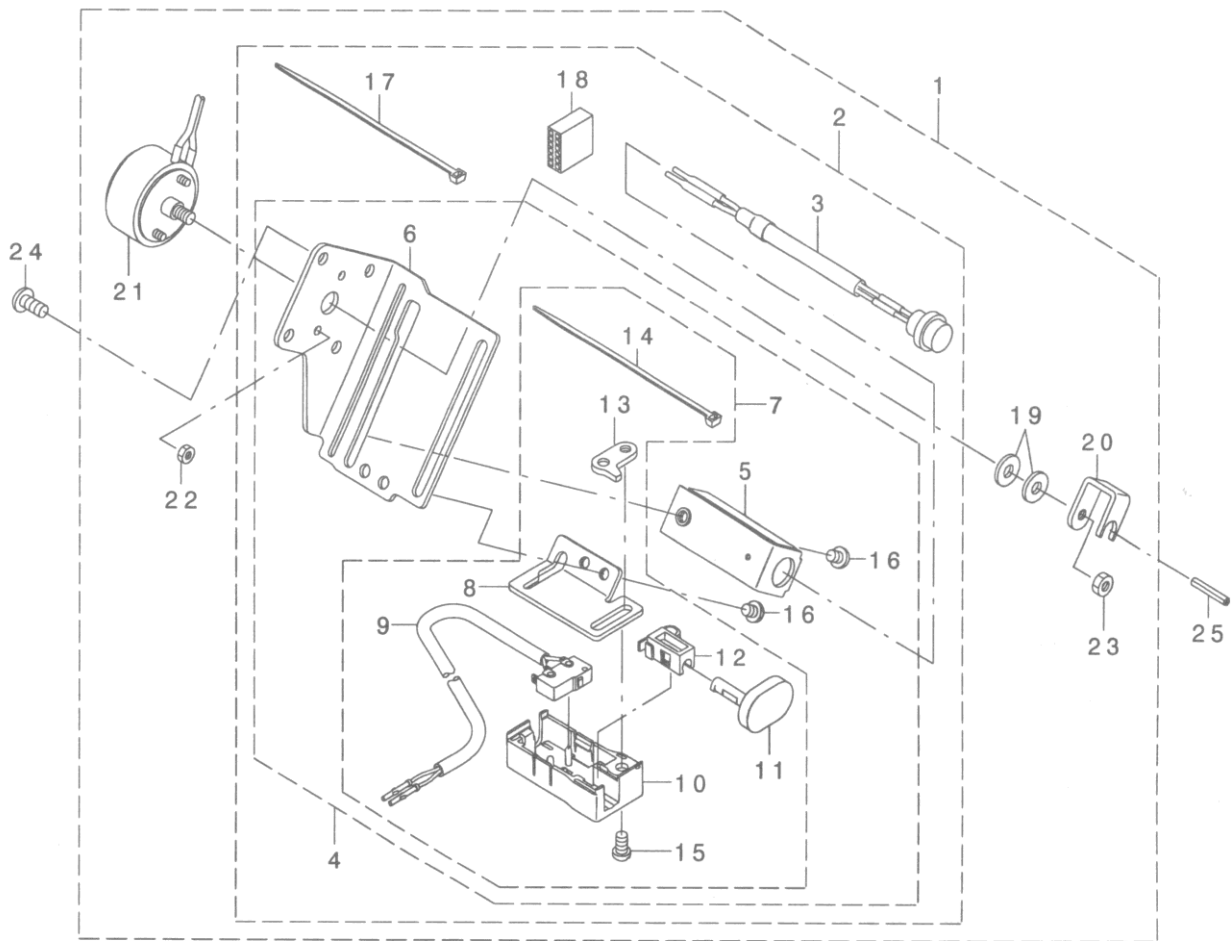

序号REF. NO.	图号 PART NO.	名称	NAME	用量AMT. REQ.	
18-01	01	400-03572	电磁铁组件	SOLENOID COMPL. A	1
18-02		400-03574	手控开关座组件	MANUAL SWITCH BASE COMPL. A	1
18-03		400-03570	指示灯	SW LED CABLE A ASM.	1
18-04		400-03577	手控开关座组件	MANUAL SWITCH BASE ASM. A	1
18-05		400-03575	上下开关座	UP-AND-DOWN SWITCH BASE	1
18-06		400-03578	松线电磁铁固定板	MANUAL SWITCH BASE	1
18-07		400-03579	接触开关座组件	TOUCH BACK SWITCH BASE ASM.	1
18-08		400-03580	接触开关座	TOUCH BACK SWITCH BASE	1
18-09		400-03581	电器开关	REVERSE FEED CORD ASM.	1
18-10		236-31708	松线开关盖	REVERSE FEED SWITCH COVER	1
18-11		236-31807	按钮	REVERSE FEED SWITCH SHAFT	1
18-12		236-31906	开关弹簧	REVERSE FEED SWITCH SUPPORT	1
18-13		236-32102	导向座	REVERSE FEED SWITCHBASE GUIDE	1
18-14		EA-9500B01-00	电线自锁夹	CABLE BAND	1
18-15		SS-7110740-TP	螺钉	SCREW	1
18-16		SS-4110515-SP	螺钉	SCREW	3
18-17		EA-9500B01-00	电线自锁夹	CABLE BAND	1
18-18		HK-0346101-20	线插座外壳	HOUSING	1
18-19		137-05603	垫片	FRAME SIDE COVER GASKET	2
18-20		225-52905	松线板	THREAD RELEASE PUSH PLATE	1
18-21		400-03651	松线电磁铁	THREAD RELEASE SOLENOID COMPL.	1
18-22		NM-6030001-SC	电磁铁小螺母	NUT	2
18-23		NM-6040001-SN	电磁铁大螺母	NUT	1
18-24		SS-4121015-SP	电磁铁固定板紧固螺钉	SCREW	4
18-25		PS-0300182-KF	松线板弹簧销	SPRING PIN	1

19. 油路部件 LUBRICATION COMPONENTS

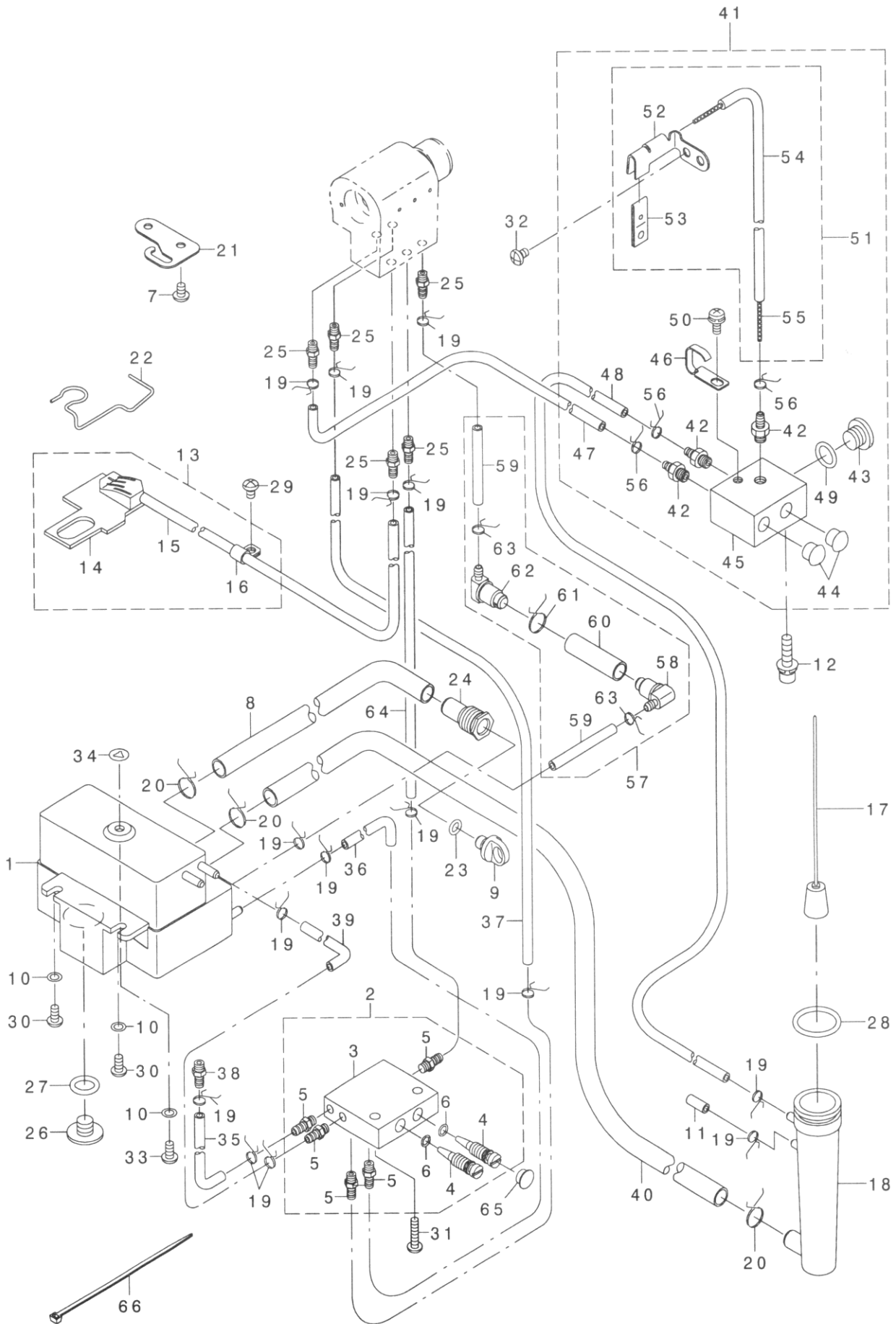

序号REF. NO.	图号 PART NO.	名称	NAME	用量AMT. REQ.
19-01	400-03629	油盒	OIL TANK ASM.	1
19-02	235-39372	油量调节阀组件	HOOK OIL REGULATING ASM.	1
19-03	235-39315	油量调节阀	HOOK OIL REGULATING	1
19-04	235-39414	油量调节杆	HOOK OIL REGULATING SCREW	2
19-05	236-29801	油管接头	LUBRICATION CONNECTOR	5
19-06	R0-0371801-00	油量调节阀O型圈	RUBBER RING	2
19-07	SS-4120615-SP	油管定位板螺钉	SCREW	2
19-08	236-30106	总进油管	TUBE B	0.4
19-09	400-00344	油管口保护盖	LUBRICATING INLET CAP	1
19-10	WP-0460556-SD	油泵紧固螺钉垫片	WASHER	3
19-11	235-40305	油杯保护盖	FLOATER CASE CAP	1
19-12	SL-6052092-TN	中转箱固定螺钉	SCREW	2
19-13	235-40057	毛毡组件	FELT	1
19-14	235-40008	回油毛毡	OIL FELT	1
19-15	236-30007	回油管	TUBE	0.07
19-16	B3536-122-000	回油管夹	HOLDER	1
19-17	236-28357	油标组件	FLOATER ASM.	1
19-18	236-28704	油杯	FLOATER CASE	1
19-19	236-29306	小油管紧固簧	PIPE STOPPER A	15
19-20	236-29405	大油管紧固簧	PIPE STOPPER B	3
19-21	235-39703	油管定位板	LUBRICATION TANK PIPE GUIDE	1
19-22	235-40107	毛毡压簧	ONCE THROUGH OIL FELT PRESSER	1
19-23	R0-0481901-00	O型圈	RUBBER RING	1
19-24	400-00343	加油杯	OIL INLE	1
19-25	236-29801	油管接头	LUBRICATION CONNECTOR	5
19-26	236-30205	油盒短螺钉	SCREW	1
19-27	R0-0982401-00	油盒O型圈	RUBBER RING	1
19-28	R0-1952401-00	油杯O型圈	RUBBER RING	1
19-29	SS-4110615-SP	机头润滑油管毡安装板螺钉	SCREW	1
19-30	SS-4110815-SP	油盒紧固螺钉	SCREW	2
19-31	SS-4121615-SP	油量调节阀紧固螺钉	SCREW	2
19-32	SS-4110615-SP	回油管夹螺钉	SCREW	2
19-33	SS-4111415-SP	油盒长螺钉	SCREW	1
19-34	M8002-430-000	锁紧垫片	STOPPER	1
19-35	236-30007	旋梭进油管	TUBE	0.07
19-36	236-30007	中转箱吸油管2	2 TUBE	0.15
19-37	236-30007	旋梭供油管	TUBE	0.16
19-38	236-29801	油管接头	LUBRICATION CONNECTOR	1
19-39	236-30007	调节阀回油管	TUBE	0.18
19-40	236-30106	油杯长油管	TUBE B	0.31
19-41	235-40552	表面润滑组件	FACE LUBRICATION TANK ASM.	1
19-42	SQ-1150451-MZ	油管接头	LUBRICATION CONNECTOR	3
19-43	SS-7740740-SP	中转箱O型圈螺钉	SCREW	1
19-44	TA-0850604-R0	橡皮塞	RUBBER PLUG	2
19-45	235-40503	机头供油中转箱	OIL BOX	1
19-46	400-22407	油管夹	LUBRICATION OIL WICK SROPPER	1
19-47	236-30007	中转箱供油油管	TUBE	0.48
19-48	236-30007	中转箱回油管	TUBE	0.19
19-49	R0-0982401-00	中转箱O型圈	RUBBER RING	1
19-50	SL-4051091-SC	油管夹螺钉	SCREW	1
19-51	235-39562	机头润滑油管组件	FACE LUBRICATION PRESSER ASM.	1
19-52	235-39505	机头润滑油管毡安装板	FACE LUBRICATION PRESSER	1
19-53	B3518-280-000	机头润滑油管毡	BALANCE LUBRICATING	1
19-54	236-30007	机头润滑油管	TUBE	0.42
19-55	CQ-2200000-00	机头润滑油线	OIL WICK	0.46
19-56	236-29306	小油管紧固簧	PIPE STOPPER A	3
19-57	236-30452	机油过滤器组件	OIL FILTER ASM.	1
19-58	236-30007	油管二接头	DISTRIBUTOR	0.09
19-59	236-30106	吸油管	TUBE	0.04
19-60	236-29405	过滤网油管	TUBE	2
19-61	236-30650	大油管紧固簧	PIPE STOPPER B	1
19-62	236-30601	油管二接头组件	DISTRIBUTOR ASM.	1
19-63	236-29306	小油管紧固簧	PIPE STOPPER A	2
19-64	236-30007	中转箱吸油管1	TUBE	0.11
19-65	TA-0750404-R0	调节阀油塞	RUBBER PLUG	1
19-66	EA-9500B01-00	电线自锁夹	CABLE BAND	1

20. 拨线部件

WIPER MECHANISM COMPONENTS

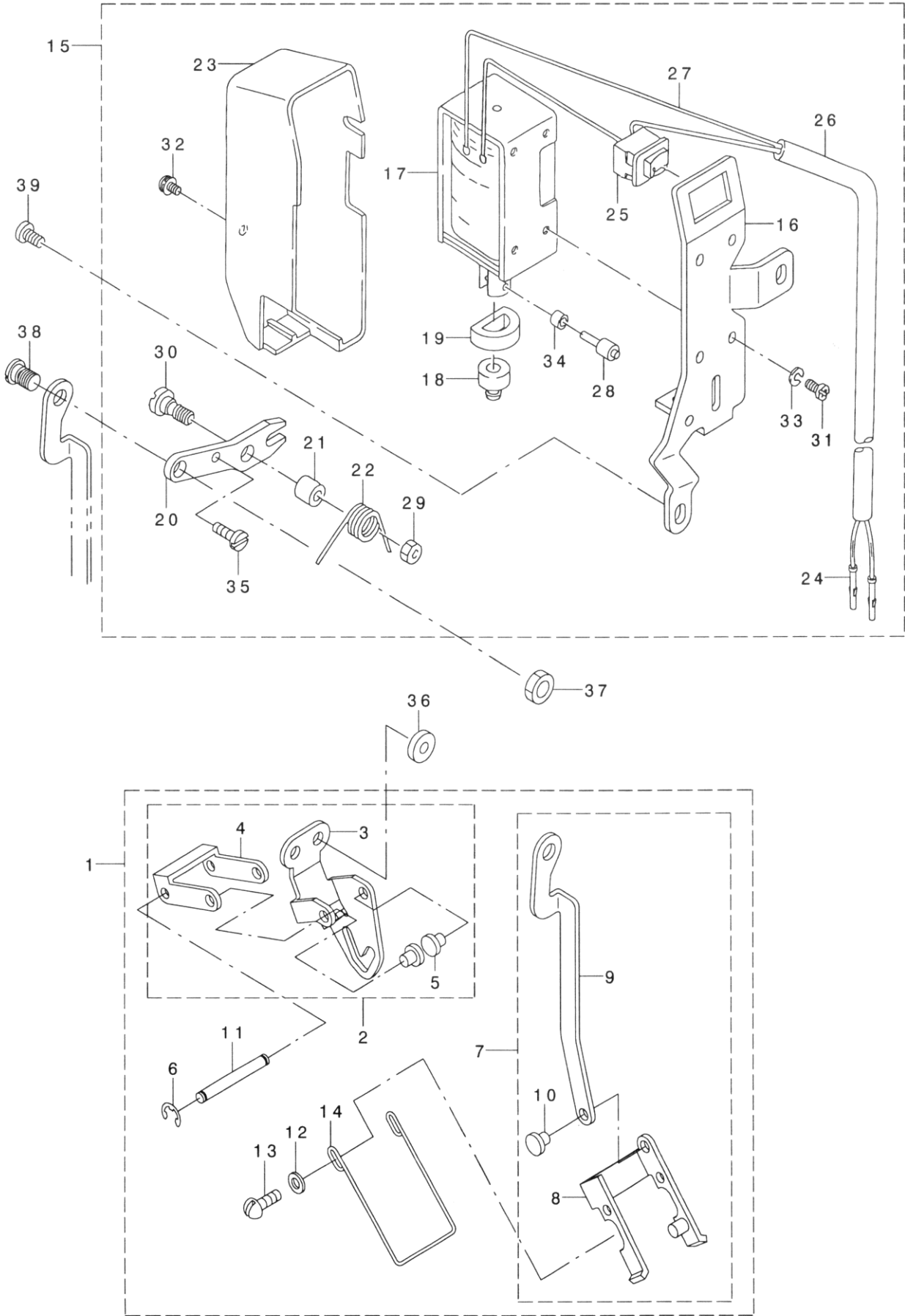

序号REF. NO.	图号 PART NO.	名称	NAME	用量AMT. REQ.
20-01	235-61757	拨线器组件	WIPER ASM.	1
20-02	235-61856	拨线器架组件	WIPER BASE ASM.	1
20-03	25-61807	拨线器固定座	WIPER BASE	1
20-04	102-08601	拨线器固定架	WIPER BASE	1
20-05	D2107-490-D00	小连板连接销	PIN	2
20-06	RE-0320000-K0	开口卡簧	E-RING	2
20-07	225-61955	驱动板组件	WIPER LINK COMPL.	1
20-08	102-08858	拨动架	WIPER LINK ASM. 2	1
20-09	225-61906	驱动板	WIPER LINK	1
20-10	D2107-490-D00	驱动板连接销	PIN	1
20-11	102-08700	拨线杆架连接销	WIPER LINK SHAFT	1
20-12	WP-0371016-SD	拨线杆垫片	WASHER	2
20-13	SS-3090520-SP	拨线杆螺钉	SCREW	2
20-14	225-61708	拨线杆	WIPER	1
20-15	400-03653	拨线电磁铁组件	WIPER SOLENOID ASM.	1
20-16	225-62102	拨线电磁铁固定架	WIPER BASE	1
20-17	111-10301	拨线电磁铁	WIPER SOLENOID	1
20-18	111-10400	铁芯复位垫	WIPER RUBBER A	1
20-19	111-10509	铁芯橡皮垫	WIPER RUBBER B	1
20-20	225-62201	拨线传动板	WIPER LINK	1
20-21	111-10707	轴位螺钉定位套	WIPER HINGE SCREW COLLAR	1
20-22	111-10806	传动板复位簧	WIPER SPRING	1
20-23	110-72709	拨线器罩	WIPER COVER	1
20-24	HK-0346400-0B	针式接头	PIN CONTACT	1
20-25	HA-0005900-00	拨线器开关	POWER SWITCH	1
20-26	HW-5F18S12-28	双芯软线	TWO-CORE CORD	1.7
20-27	HW-2003900-00	电线	ELECTRIC WIRE	0.04
20-28	111-12000	铁芯传动销	POWER SWITCH	1
20-29	NS-6110310-SP	传动板轴位螺钉螺母	NUT	1
20-30	SD-0650321-TP	传动板轴位螺钉	HINGE SCREW	1
20-31	SM-4030601-SN	拨线电磁铁安装螺钉	SCREW	4
20-32	SL-4030631-SC	拨线器罩螺钉	SCREW	1
20-33	WS-0310002-KR	安装螺钉垫圈	SCREW	4
20-34	111-11804	传动销滚柱	WIPER LINK COLLAR	1
20-35	SS-6111040-SP	弹簧复位螺钉	SCREW	1
20-36	MAO-91003000	拨线器固定螺钉垫片	WASHER	2
20-37	NS-6110310-SP	驱动板螺钉螺母	NUT	1
20-38	SD-0600271-SP	驱动板轴位螺钉	SCREW	1
20-39	SS-4120615-SP	拨线电磁铁架螺钉	SCREW	2

序号REF. NO.	图号 PART NO.	名称	NAME	用量AMT. REQ.
21-01	400-03603	膝提组件	UNDER COVER ASM.	1
21-02	400-03604	油盘	UNDER COVER	1
21-03	110-47107	橡皮垫	RUBBER CUSHION	2
21-04	101-62600	橡皮垫	RUBBER CUSHION	2
21-05	229-32453	托架组件	BRACKET ASM.	1
21-06	229-32404	连接头	BRACKET	1
21-07	SM-9062053-SR	螺钉	SCREW	2
21-08	400-03606	膝控旋臂组件	KNEE LIFTER ROTATING ARM ASM.	1
21-09	236-39107	连接座	BRACKET	1
21-10	SM-8063012-TR	螺钉	SCREW	2
21-11	NM-60600001-SE	螺母	NUT	2
21-12	236-39206	连接架	CONNECTING ROT	1
21-13	236-39305	膝控连接轴	KNEE PRESS ROD	1
21-14	236-39404	轴	SHAFT	1
21-15	236-39503	弹簧	SPRING	1
21-16	236-39602	连杆片	CONNECTING ROD	1
21-17	NS-6150310-SP	螺母	NUT	2
21-18	RE-1000000-KO	E型开口挡圈	E-RING	2
21-19	RE-1000000-KO	E型开口挡圈	E-RING	1
21-20	SD-0720331-SP	铰链螺钉	HINGE SCREW	2
21-21	SM-9061853-SR	螺钉	SCREW	1
21-22	SM-9061853-SR	螺钉	SCREW	1
21-23	WP-0650876-SD	垫圈	WASHER	2
21-24	400-03605	散热扇	COOLING FAN	1
21-25	400-03607	过滤器	FILTER	2
21-26	229-44508	电线压脚	WIRE PRESSER A	2
21-27	HM-0008600-10	风扇防尘罩	FAN LIFTER	1
21-28	SM-1044050-SM	螺钉	SCREW	2
21-29	SM-4040601-SC	螺钉	SCREW	2
21-30	141-01208	机架载体棒	MACHINE FRAME SUPPORT ROD	1
21-31	229-34251	操纵杆部件	KNEE PAD PLATE RUBBER	1
21-32	229-34202	操纵板	KNEE PAD PLATE ASM.	1
21-33	229-34301	操纵杆接头	KNEE PAD PLATE SUPPORT	1
21-34	229-34400	操纵杆垫	KNEE PAD PLATE RUBBER	1
21-35	229-34509	操纵杆软垫	KNEE PAD PLATE COVER	1
21-36	229-34608	操纵杆	KNEE PAD UPRIGHT SHAFT	1
21-37	SM-9061203-SE	接头螺钉	SCREW	1

22. 线架部件

THREAD STAND COMPONENTS

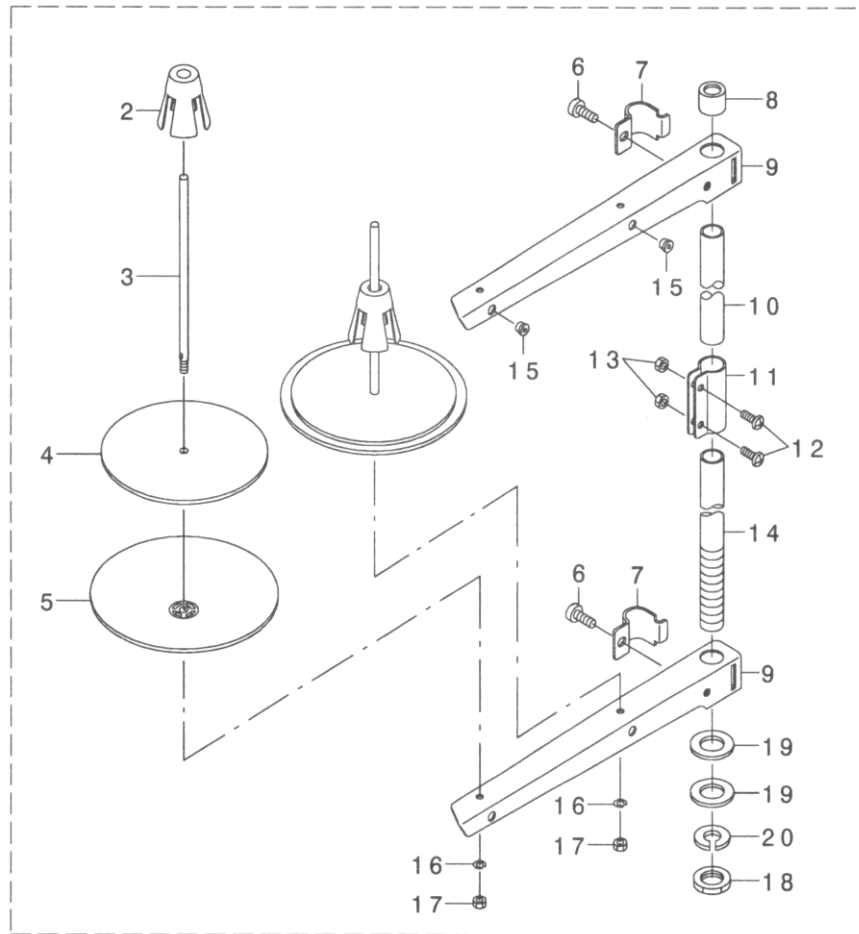

序号REF. NO.	图号 PART NO.	名称	NAME	用量AMT. REQ.
22-01	229-30358	过线架部件	THREAD STAND ASM.	1
22-02	229-31109	线团防松垫	SPOOL RETAOMER	2
22-03	229-31000	线盘钉	SPOOL PIN	2
22-04	229-30903	线盘软垫	SPOOL REST CUSHION	2
22-05	229-30804	线盘	SPOOL REST	2
22-06	SM-6061610-SC	线架过线架螺钉	SCREW	2
22-07	229-30705	线架过线夹	THREAD GUIDE ARM JOINT	2
22-08	229-31406	线架杆顶防护橡皮	SPOOL REST ROD RUBBER CAP	1
22-09	229-30507	线架过线杆	SPOOL REST ARM	2
22-10	229-30408	线架杆上节	SPOOL REST ROD. UPPER	1
22-11	229-31307	接架杆接头	SPOOL REST ROD JOINT	1
22-12	SM-4051405-SE	接架杆接头螺钉	SCREW	2
22-13	NM-6050001-SE	接架杆接头螺母	NUT	2
22-14	229-30309	线架杆下节	SPOOL REST ROD. LOWER	1
22-15	229-31208	过线圈	THREAD GUIDE	2
22-16	WS-0510002-KN	线盘钉弹簧垫	SPRING WHSHER	2
22-17	NM-6050001-SE	线盘钉螺母	NUT	2
22-18	NM-6160511-SE	线架杆紧固螺母	NUT	1
22-19	WP-170260-S0	线架杆紧固螺母垫圈	WHASHER	2
22-20	WS-1643202-KR	紧固螺母弹簧垫圈	SPRING WHSHER	1

23. 电控箱部件

ELECTRIC CABINET TRANSMISSION COMPONENTS

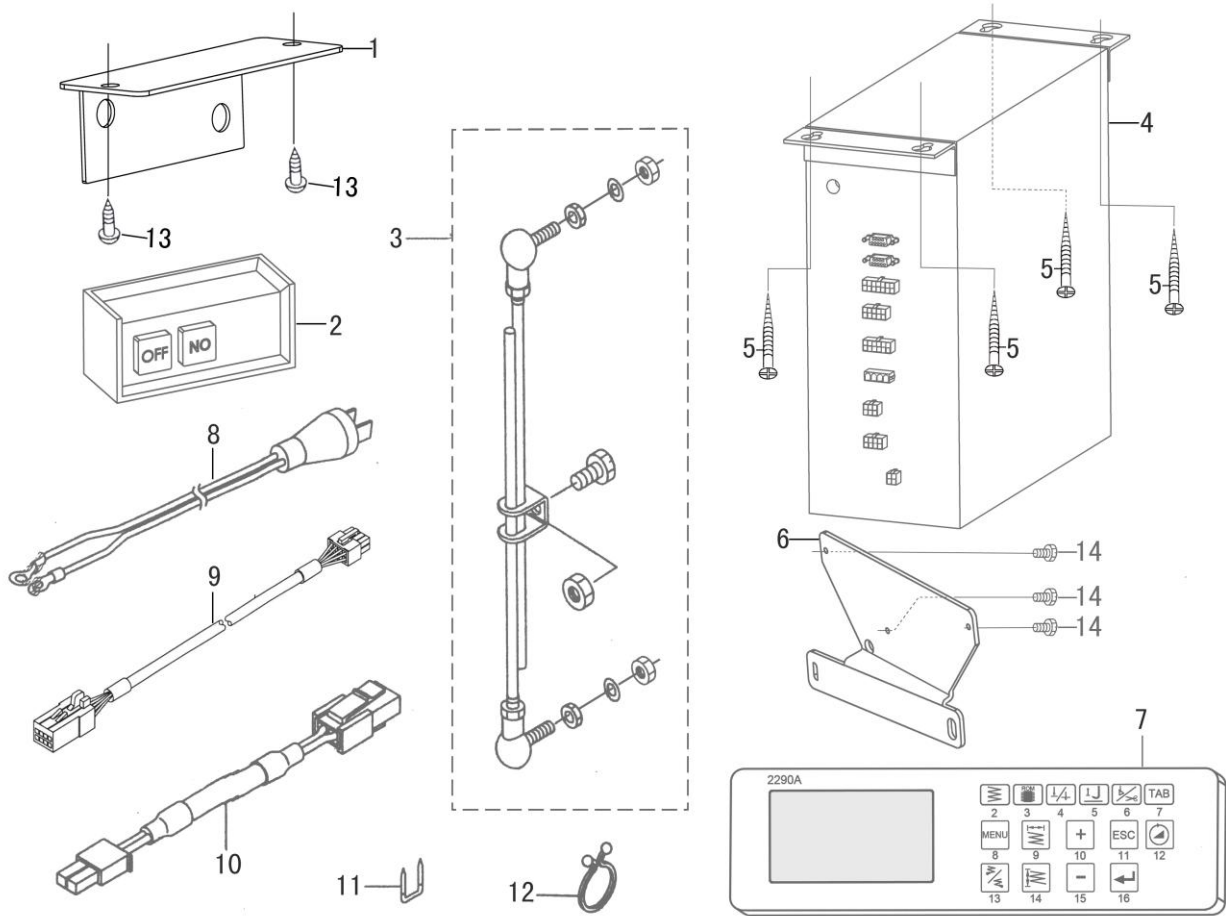

序号REF. NO.	图号 PART NO.	名称	NAME	用量AMT. REQ.
23-01		电源开关安装板	SWITCH MOUNTING PLATE	1
23-02		电源开关	SWITCH	1
23-03		脚踏拉杆组件	CONNECTING ROD ASM. B	1
23-04		电控箱	ELECTRIC CABINET	1
23-05		电控箱安装木螺钉	WOOD SCREW	4
23-06		操作面板安装座	OPERATION PANEL MOUNTING PLATE	1
23-07		操作面板	OPERATION PANEL	1
23-08		电源线插头	POWER SOURCE CORD ASM.	1
23-09		电控箱连接线	HEAD FAN RELAY CORD A ASM.	1
23-10		电控箱连接线	HEAD FAN RELAY CORD A ASM.	1
23-11		线夹	CORD STAPLE	1
23-12		线扣	SPRING WASHER, M8	1
23-13		木螺钉	WOOD SCREW	2
23-14		螺钉	SCREW	3

27. 附件

ACCESSORIES PART COMPONENTS

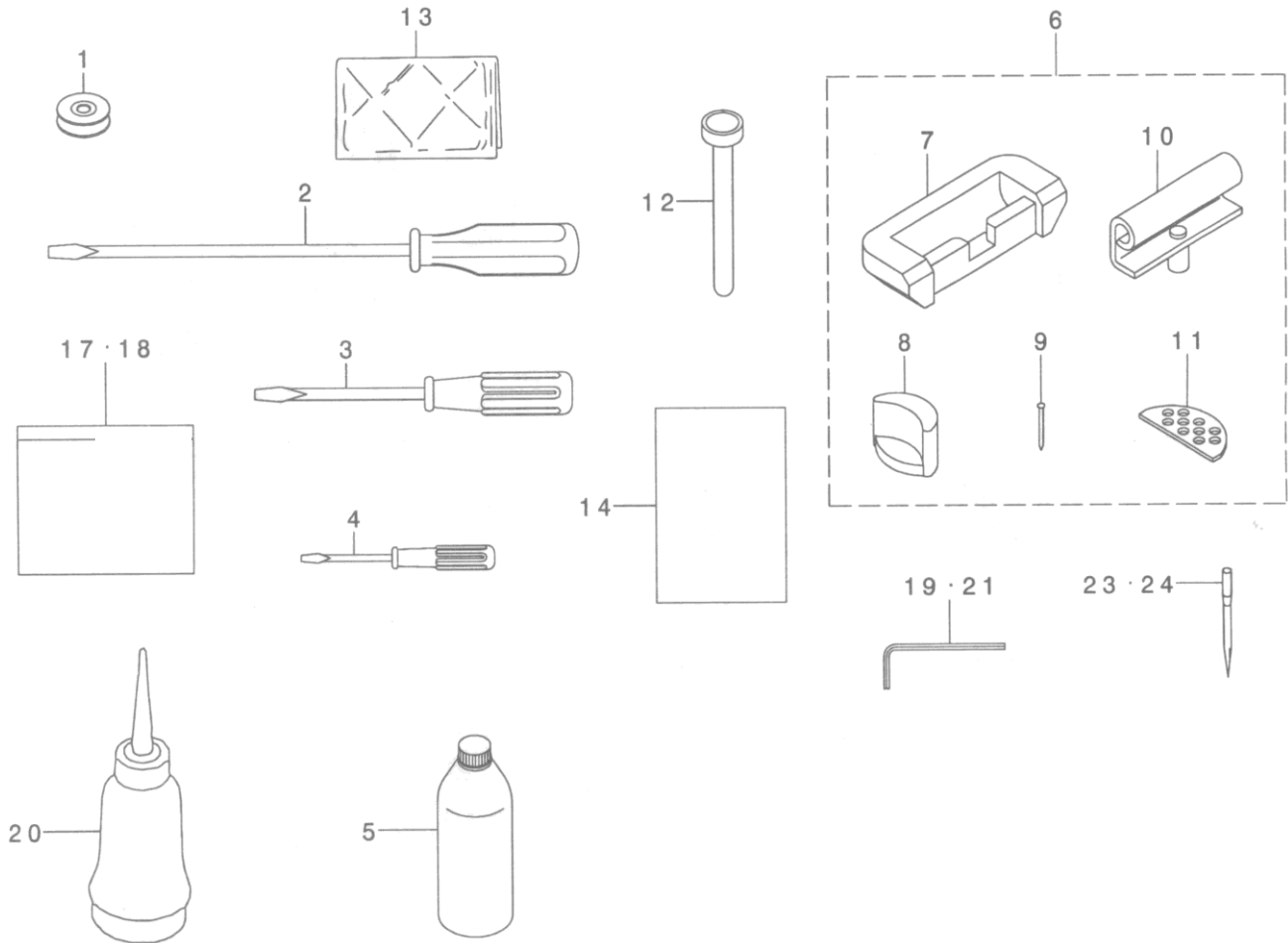

序号REF. NO.	图号 PART NO.	名称	NAME	用量AMT. REQ.	
27-01	225-96704	梭心	BOBBINS	1	
27-02	229-33006	大螺丝刀	SCREW DRIVER. LARGE	1	
27-03	229-33105	中螺丝刀	SCREW DRIVER. MIDDLE	1	
27-04	229-33204	小螺丝刀	SCREW DRIVER. SMALL	1	
27-05	MDF-RX1600C0	油箱	DEFRIX OIL NO. 1	1	
27-06	02	229-58052	橡胶铰链组件	RUBBER HINGE ASM.	1
27-07	229-26000	机头连接钩座	RUBBER CUSHION	2	
27-08	229-58003	油盘支座	FRAME RUBBER CUSHION	2	
27-09	229-26208	油盘座钉	NAIL	8	
27-10	229-26356	铰链组件	HINGE COMPL.	2	
27-11	229-26505	机头连接钩座钉	WASHER	2	
27-12	236-39701	抬压脚顶杆	KNEE LIFTER PRESSER ROD	1	
27-13	02	262-34005	机头塑料膜	VINYL COVER	1
27-14	293-42409	合格证部件	EC PRODUCTION DECLARATION	1	
27-17	229-32800	机头罩	ACCESSORIE BAG	1	
27-18	B101-552-000	工具箱	ACCESSORY BOX	1	
27-19	B9102-057-000	扳手	WRENCH	1	
27-20	B9121-012-0A0	油壶	OILER ASM.	1	
27-21	J1066-000-00B	六角套筒扳手	HEXAGONAL WRENCH KEY	1	
27-23	02	MC-1923007-52	机针	NEEDLE	1
27-24	02	MDP-500B1002	机针	NEEDLE	1

杰克缝纫机

全球销量遥遥领先

Leading in global sales

400-8876-858
www.chinajack.com



台州市布鲁斯缝制设备有限公司
中国浙江省台州市椒江区三甲东海大道东段1008号
电话: 4008890100

.TD.

TaiZhou Bruce Sewing Machine Co.,Ltd.
NO.1008 , DONGHAI AVENUE EAST, JIAOJIANG
DISTRICT,TAIZHOU CITY , ZHEJIANG
TEL: 4008890100

2019年1月Edition: June,2019

杰克缝纫机股份有限公司

中国浙江省台州市椒江区三甲东海大道东段1008号

电话 :0086-576-88177788 88177789

传真 :0086-576-88177758

产品标准代号 : Q/TK 007-2017

资料如有更改, 恕不另行通知, 以实样为准

JACK SEWING MACHINE CO.,LTD.

No. 1008,DONGHAI AVENUE EAST,JIAOJAING DISTRICT,TAIZHOU CITY,ZHEJIANG

TEL: 0086-576-88177782 88177767 E-mail: sales@chinajack.com

FAX: 0086-576-88177787

www.chinajack.com

Standard code of the products:Q/TK 007-2017

You will be not informed if the file has been revised. Please set sample as standard.