

ENGLISH

**LK-1900BN Series
INSTRUCTION MANUAL**

CONTENTS

I. EXPLANATION OF THE LK-1900BN, COMPUTER-CONTROLLED HIGH- SPEED BARTACKING MACHINE	1
1. SPECIFICATIONS.....	1
2. CONFIGURATION	2
2-1. Names of main unit	2
2-2. Names and explanation of switches on the operation panel.....	3
3. INSTALLATION.....	4
3-1. Installing the electrical box	4
3-2. Installing the pedal sensor	4
3-3. Attaching the connecting rod.....	5
3-4. Installing the head support rod.....	5
3-5. Installing and connecting the power switch ...	6
3-6. How to carry the sewing machine.....	7
3-7. Installation of the sewing machine head.....	7
3-8. Installing the drain receiver and the head support rubber.....	8
3-9. Safety switch.....	8
3-10. Tilting the sewing machine head	9
3-11. Installing the operation panel	9
3-12. Connecting the cords	10
3-13. Handling the cords.....	11
3-14. Installing the eye protection cover.....	12
3-15. Installing the thread stand	13
3-16. In the case the machine is transported after factory-completed at the time of shipment	13
4. OPERATION OF THE SEWING MACHINE.....	14
4-1. Lubrication	14
4-2. Attaching the needle	14
4-3. Threading the machine head.....	15
4-4. Installing and removing the bobbin case.....	15
4-5. Installing the bobbin	16
4-6. Adjusting the thread tension.....	16
4-7. Adjusting the thread take-up spring.....	17
4-8. Example of the thread tension	17
5. OPERATION OF THE SEWING MACHINE (BASIC).....	17
5-1. Selection of language	17
5-2. Setting the pattern number.....	18
5-3. Setting the item data	18
5-4. Checking the contour of a sewing pattern....	21
5-5. Sewing	22
5-6. Changing the pattern to a different one	22
5-7. Winding a bobbin	23
5-8. Thread clamp device.....	24
5-9. LED hand light	26
6. OPERATION OF THE SEWING MACHINE (ADVANCED).....	27
6-1. Performing sewing using the pattern keys ..	27
6-2. Sewing using the combination function (cycle sewing).....	32
6-3. Sewing through the use of the counter.....	35
6-4. How to use the temporary stop.....	38
6-5. Setting the pattern thread tension.....	39
6-6. Copying or deleting various kinds of pattern data.....	40
6-7. Communication	42
6-8. Cautions in operation.....	45
6-9. Setting enable/disable of standard pattern invoking.....	46
6-10. Setting the irregular work	47
7. MAINTENANCE	49
7-1. Adjusting the height of the needle bar	49
7-2. Adjusting the needle-to-shuttle relation.....	50
7-3. Adjusting the lift of the work clamp foot.....	51
7-4. The moving knife and counter knife	51
7-5. Needle thread clamp device	52
7-6. Adjustment of the wiper.....	52
7-7. Draining waste oil.....	53
7-8. Amount of oil supplied to the hook	53
7-9. Replacing the fuse.....	53
7-10. Replenishing the designated places with grease.....	54
8. HOW TO USE THE MEMORY SWITCH	56
8-1. Method of changing memory switch data.....	56
8-2. List of the memory switch functions	57
9. OTHERS	61
9-1. Table of the standard pattern specifications	61
9-2. Table of the standard patterns	62
9-3. Table of the work clamp foot.....	64
9-4. Installing the foot pedal switch (optional)....	66
9-5. Error list.....	67
9-6. Message list	72
9-7. Troubles and corrective measures (sewing conditions).....	74
9-8. Table of the optional parts.....	76
II. EXPLANATION OF THE LK-1901BN, COMPUTER-CONTROLLED HIGH- SPEED EYELET BUTTONHOLE BARTACKING MACHINE	78
1. SPECIFICATIONS.....	78
2. INSTALLATION OF THE SEWING MACHINE AND PREPARATION OF THE OPERATION	78
3. PREPARATION OF THE SEWING MACHINE	79
3-1. Adjustment of the material closing amount..	79
3-2. Adjustment of the lift of the work clamp foot	79
3-3. Adjustment of the pressure of the work clamp unit	80
3-4. Setting of the material closing operation.....	80
4. OPERATION OF THE SEWING MACHINE.....	81
4-1. Selection and confirmation of the sewing patterns	81

III. EXPLANATION OF THE LK-1902B, COMPUTER-CONTROLLED HIGH- SPEED BELT-LOOP ATTACHING MACHINE	82
1. SPECIFICATIONS.....	82
2. PREPARATION OF THE SEWING MACHINE	82
2-1. Threading the machine	82
3. OPERATION OF THE SEWING MACHINE.....	83
3-1. Selection and confirmation of the sewing patterns	83
3-2. Combination of the work clamp foot and the feed plate	83
IV. EXPLANATION OF THE LK-1903BN, COMPUTER-CONTROLLED HIGH- SPEED LOCKSTITCH BUTTON SEWING MACHINE	84
1. SPECIFICATIONS.....	84
2. PREPARATION OF THE SEWING MACHINE	84
2-1. Installation of the sewing machine and preparation of the operation	84
2-2. Needle and thread	84
2-3. Various sewing modes.....	85
3. ADJUSTMENT OF THE SEWING MACHINE	86
3-1. Position of the button clamp jaw lever.....	86
3-2. Adjusting the feed plate	87
3-3. Adjusting the button clamp jaw lever.....	88
3-4. Adjusting the lifting amount of the button clamp	88
3-5. Adjustment of the pressure of the work clamp unit	89
3-6. Adjustment of the wiper spring.....	89
4. OTHERS	90
4-1. Installing the save button bar (accessory part)	90
4-2. Model classification according to the button size	90
4-3. Attaching the shank button (optional).....	91
V. EXPLANATION OF THE LK- 1903BBN HIGH-SPEED COMPUT- ER-CONTROLLED FLAT BUTTON SEWING MACHINE (WITH THE BIRD'S NEST PREVENTING AND SHORTER-THREAD REMAINING TYPE THREAD TRIMMER).....	95
1. SPECIFICATIONS.....	95
2. PREPARATION OF THE SEWING MACHINE	95
2-1. Installation of the sewing machine and preparation of the operation	95
2-2. Installing the regulator and solenoid valve asm.	96
2-3. Connecting the air piping	96
2-4. Connecting the cords.....	99
2-5. Installing the air hose.....	100
2-6. Installing the cloth chip bag.....	100
2-7. Fixing the finger guard.....	100
2-8. Needle and thread	101
2-9. Various sewing modes.....	101
3. ADJUSTMENT OF THE SEWING MACHINE	102
3-1. Adjusting the knife for the shorter thread remaining thread trimmer.....	102
3-2. Adjusting the suction pipe for the shorter- thread remaining type thread trimmer	103
3-3. Replacing the knife of the shorter-thread remaining type thread trimmer	104
3-4. Adjusting the work clamp rod (For 1903BBNS only).....	105
3-5. Replacing the non-slip sheet (For 1903BBNS only).....	105
4. MAINTENANCE	106
4-1. Cleaning the inside of the hook cover.....	106
4-2. Cleaning the thread clamp.....	106
VI.
EXPLANATION OF THE LK- 1900BBN COMPUTER-CON- TROLLED, HIGH-SPEED BARTACK- ING MACHINE (WITH THE BIRD'S NEST PREVENTING AND SHORT- ER-THREAD REMAINING TYPE THREAD TRIMMER)	107
1. SPECIFICATIONS.....	107
2. PREPARATION OF THE SEWING MACHINE.....	108
2-1. Table of the sewing patterns	108
3. ADJUSTMENT OF THE SEWING MACHINE	110
3-1. Replacing the bird's nest preventing knife .	110
VII. DRAWING OF THE TABLE.....	111

I. EXPLANATION OF THE LK-1900BN, COMPUTER-CONTROLLED HIGH-SPEED BARTACKING MACHINE

1. SPECIFICATIONS

1	Sewing area	X (lateral) direction 40 mm Y (longitudinal) direction 30 mm
2	Max. sewing speed	3,200 sti/min* (When sewing pitches are less than 5 mm in X-direction and 3.5 mm in Y -direction.)
3	Stitch length	0.1 to 10.0 mm (adjustable in 0.1 mm step)
4	Feed motion of work clamp foot	Intermittent feed (2-shaft drive by stepping motor)
5	Needle bar stroke	41.2 mm
6	Needle	DP × 5, DP × 17
7	Lift of work clamp foot	13 mm (standard) Max. 17 mm
8	Shuttle	Standard semi-rotary hook (oil wick lubrication)
9	Lubricating oil	New Defrix Oil No. 2 (supplied by oiler)
10	Data recording	Memory in MAIN PCB (80 Kbite)
11	Enlarging / Reducing facility	20% to 200% (1% step) in X direction and Y direction respectively
12	Enlarging / Reducing method	Pattern enlargement / reduction can be done by increasing/decreasing the stitch length
13	Max. sewing speed limitation	400 to 3,200 sti/min* (100 sti/min steps)
14	Pattern selection	Standard patterns: 51 User patterns: 1 - 200 Media patterns: 1 - 999
15	Bobbin thread counter	UP/DOWN type (0 to 9999)
16	Sewing machine motor	Servo motor
17	Dimensions	W : 1,200 mm L : 660 mm H : 1,100 mm (Use the standard table and stand.)
18	Mass	Machine head 42 kg, Control box 5.1 kg
19	Power consumption	250 VA (Pattern No. 1, 3,200 sti/min, 2-sec pause time)
20	Operating temperature range	5 °C to 35 °C
21	Operating humidity range	35% to 85% (No dew condensation)
22	Line voltage	Rated voltage ± 10% 50/60 HZ
23	Noise	- Equivalent continuous emission sound pressure level (L _{pA}) at the workstation : A-weighted value of 82 dB; (Includes K _{pA} = 2.5 dB); according to ISO 10821- C.6.3 -ISO 11204 GR2 at 3,200 sti/min for the sewing cycle, 1.0s ON (Pattern : No.1). - Sound power level (L _{WA}) ; A-weighted value of 89 dB; (Includes K _{WA} = 2.5 dB); according to ISO 10821- C.6.3 -ISO 3744 GR2 at 3,200 sti/min for the sewing cycle, 1.0s ON (Pattern : No.1).

* Reduce the max. sewing speed in accordance with the sewing conditions.
Max. sewing speed of LK-1900BNWS (double capacity hook) is 2,700 sti/min.

2. CONFIGURATION

2-1. Names of main unit

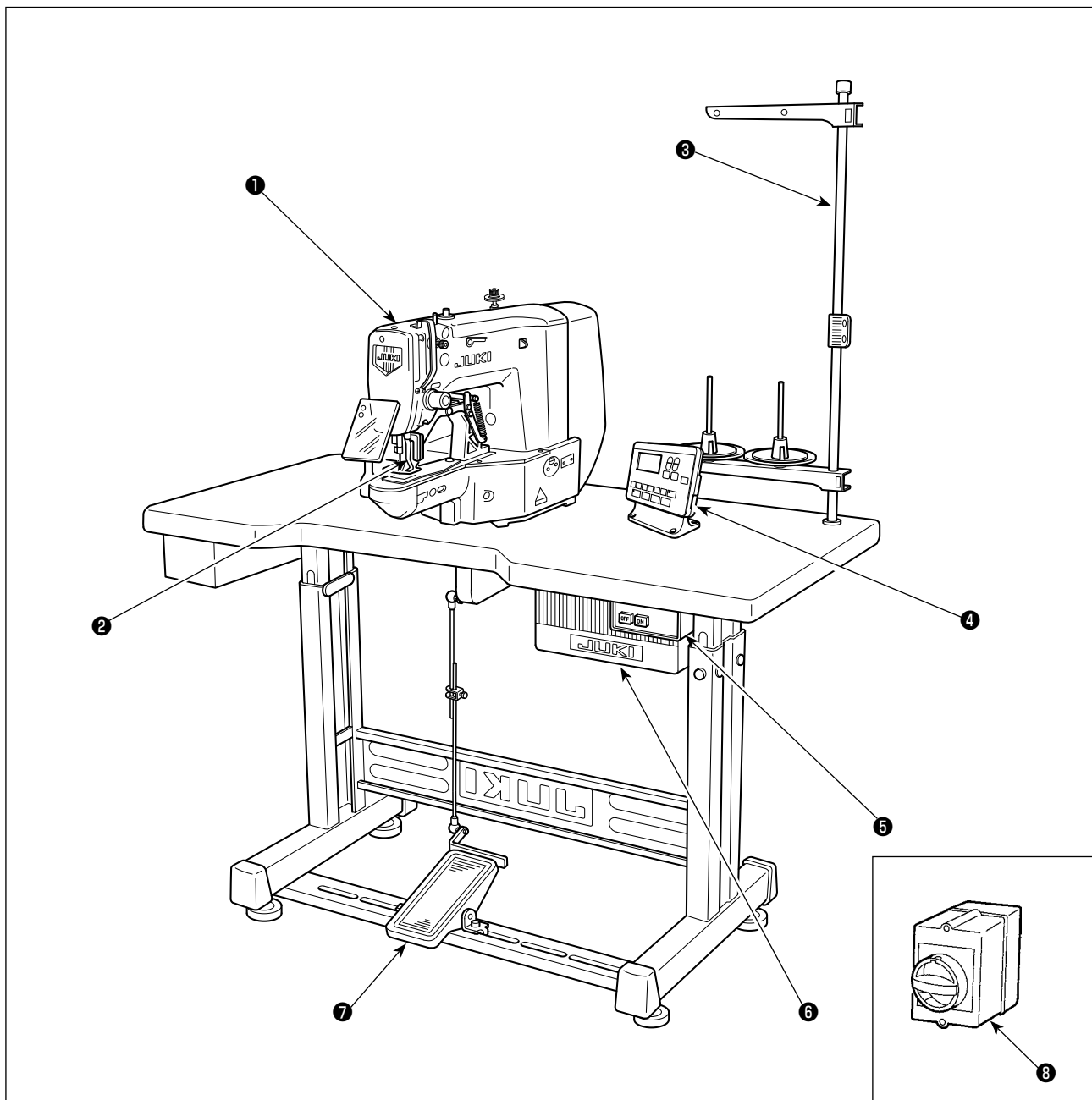

- ① Machine head
- ② Work clamp feet
- ③ Thread stand
- ④ Operation panel
- ⑤ Power switch
- ⑥ Control box
- ⑦ Pedal
- ⑧ Power switch (EU type)

2-2. Names and explanation of switches on the operation panel

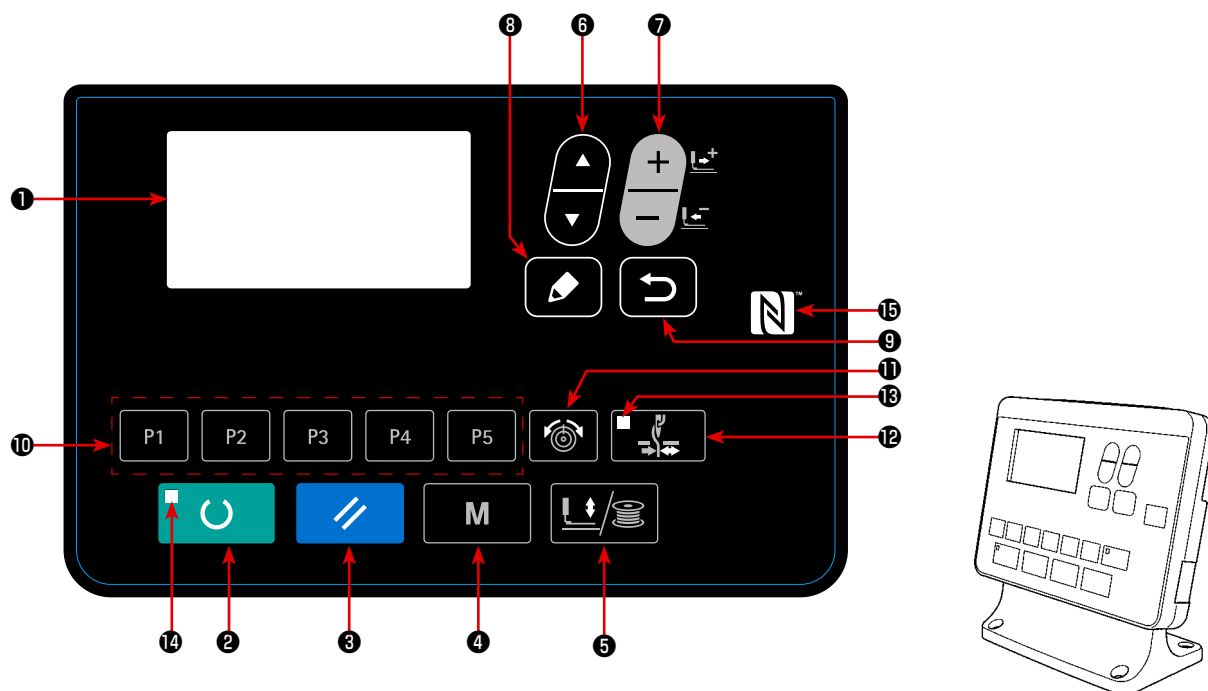

No.	NAME	FUNCTION
①	LCD display	Various data such as pattern No., shape, etc. are displayed.
②	READY key 	Press this key when starting sewing. Every time this key is pressed, change-over of sewing ready set state and data set state can be performed.
③	RESET key 	Press this key when releasing error, traveling the feed mechanism to its initial position, counter resetting, etc.
④	MODE key 	This key is used for displaying the mode screen.
⑤	PRESSER and WINDER key 	This key lifts or lowers the presser. When the presser goes up, the needle bar travels to the origin and when it comes down, the needle bar travels to the right. This key is pressed when performing bobbin winding.
⑥	ITEM SELECT key 	This key is used to select the data No. and other kinds of data.
⑦	DATA CHANGE key 	This key is used to change the pattern No. and other kinds of data. This key is used to move the feed forward on a stitch-by-stitch basis.

No.	NAME	FUNCTION
⑧	EDIT key 	This key is used to display the edit screen, to select the item or to display the detail screen.
⑨	RETURN key 	This key is used to return the screen to the previous one.
⑩	DIRECT PATTERN 	This key registers the pattern. When this key is pressed, the pattern registered here can sew immediately. X/Y scale, sewing position, etc. can be changed and registered.
⑪	THREAD TENSION key 	The thread tension screen is displayed.
⑫	THREAD CLAMP key 	This key selects effective/ineffective of needle thread clamp. When it is effective, needle thread clamp display LED lights up. (Note)
⑬	THREAD CLAMP LED	When this LED lights up, needle thread clamp operates.
⑭	SET READY LED	The LED lights up under the sewing mode.
⑮	NFC mark 	Bring the tablet or smartphone close to the NFC mark when carrying out communication.

(Note) 1. LK-1903BN is set to needle thread clamp prohibited (no motion) with memory switch U035 at the time of standard delivery.
2. For the LK-1903BBNS, the thread clamp key is disabled.

3. INSTALLATION

3-1. Installing the electrical box

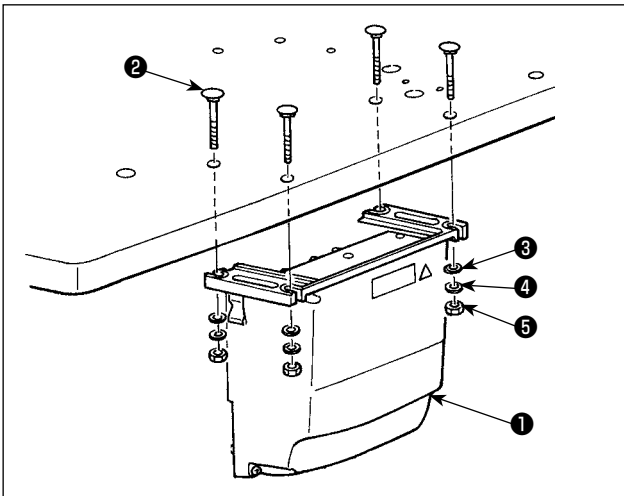

Install control box **1** to the location illustrated in the figure using four bolts **2**, four plain washers **3** and four spring washers **4** and four hexagonal nuts **5** supplied with the unit.



Bolt **2** is a cup head square neck bolt (M8; Length: 70 mm) and nut **5** is a hexagonal nut (M8).

3-2. Installing the pedal sensor

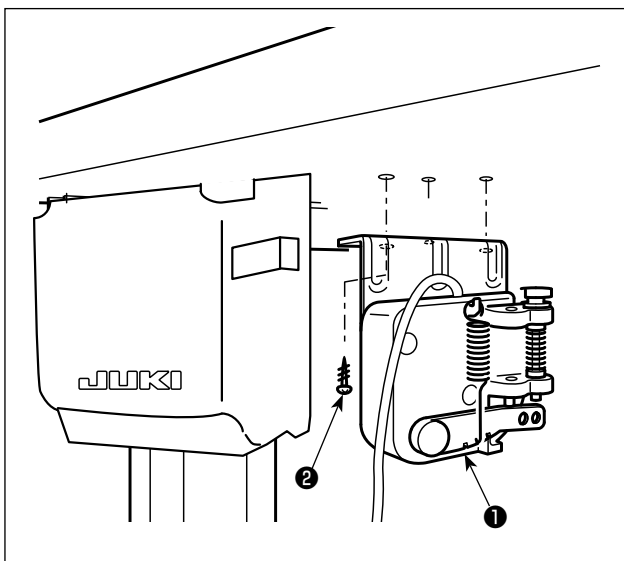

Install the pedal sensor **1** to the table with mounting screws **2** supplied with the unit.

3-3. Attaching the connecting rod

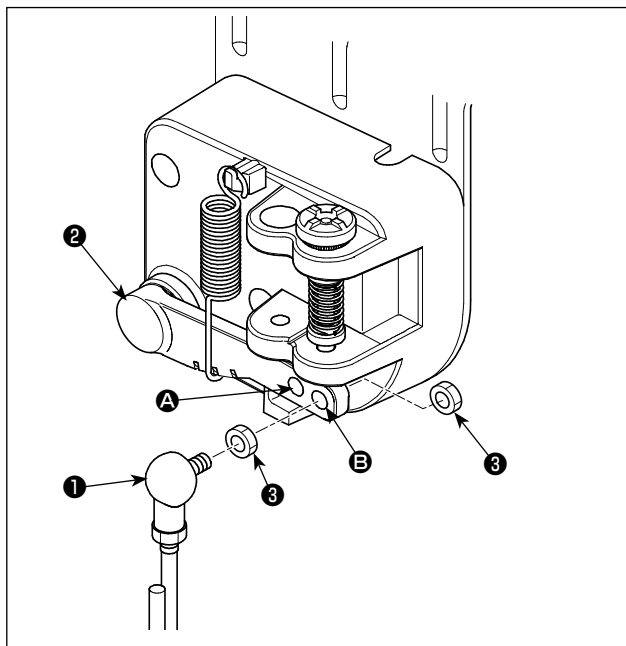

- 1) Fix connecting rod ① to installing hole B of pedal lever ② with nut ③ .
- 2) The pedal depressing stroke is decreased by fitting connecting rod ① in mounting hole A.

3-4. Installing the head support rod

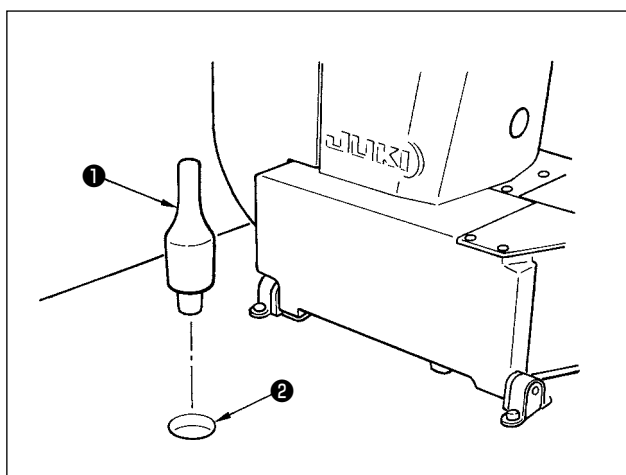

Drive head support rod ① in hole ② in the machine table.

3-5. Installing and connecting the power switch

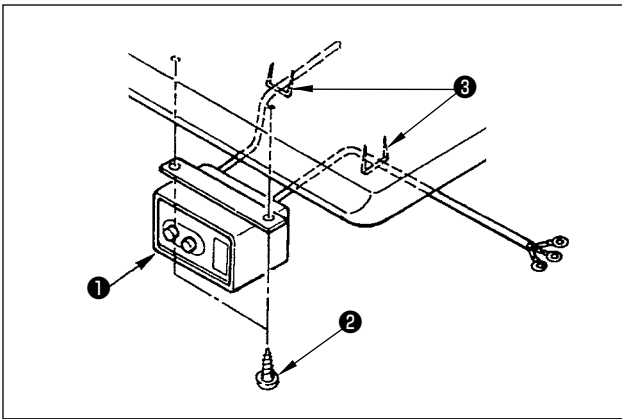

(1) Installing the power switch

Fix power switch ① under the machine table with wood screws ② .

Fix the cable with staples ③ supplied with the machine as accessories in accordance with the forms of use.

(2) Connecting the power source cord

Voltage specifications at the time of delivery from the factory are indicated on the voltage indication seal. Connect the cord in accordance with the specifications.

Power indication tag

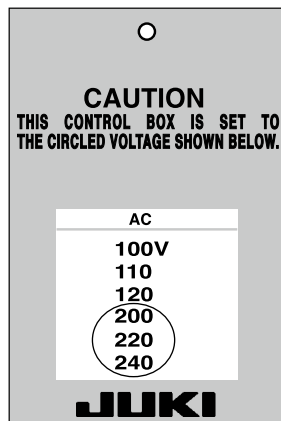

(For example: In the case of 200V)

Caution Never use under the wrong voltage and phase.

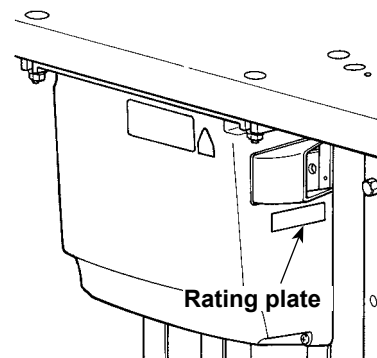

Rating plate

• Connecting single phase 200V, 220V, 230V and 240V

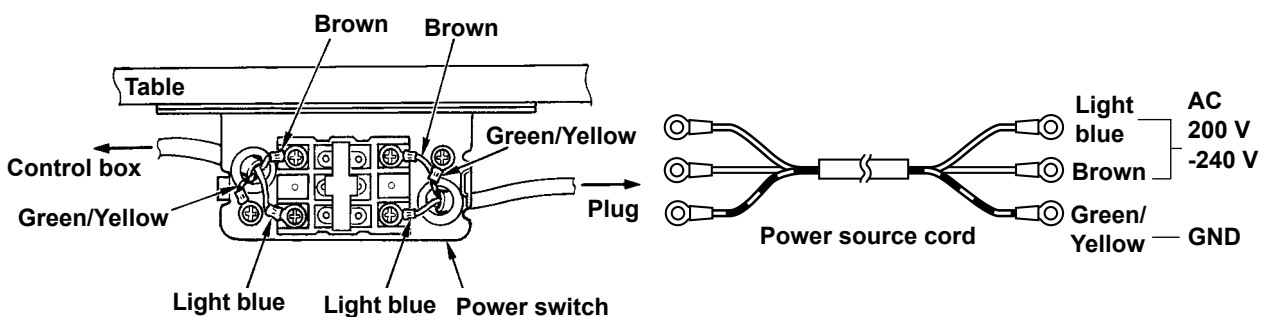

• Connecting three phase 200V, 220V, 230V and 240V

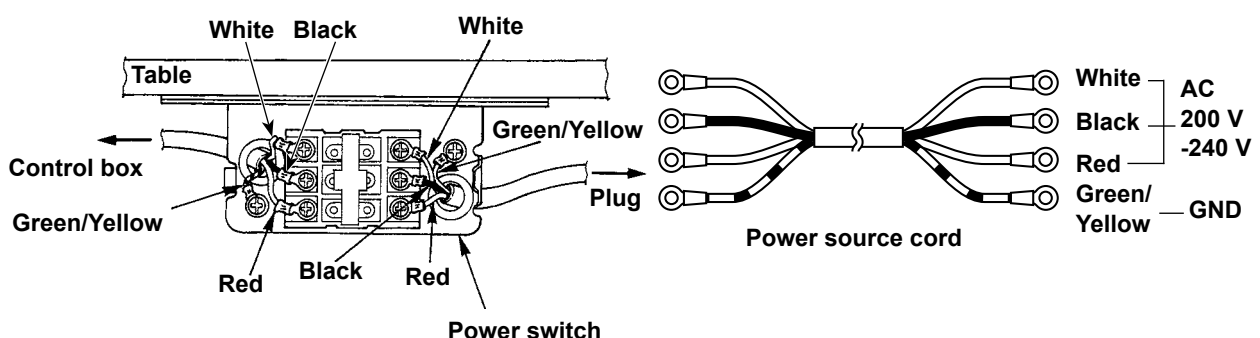

3-6. How to carry the sewing machine

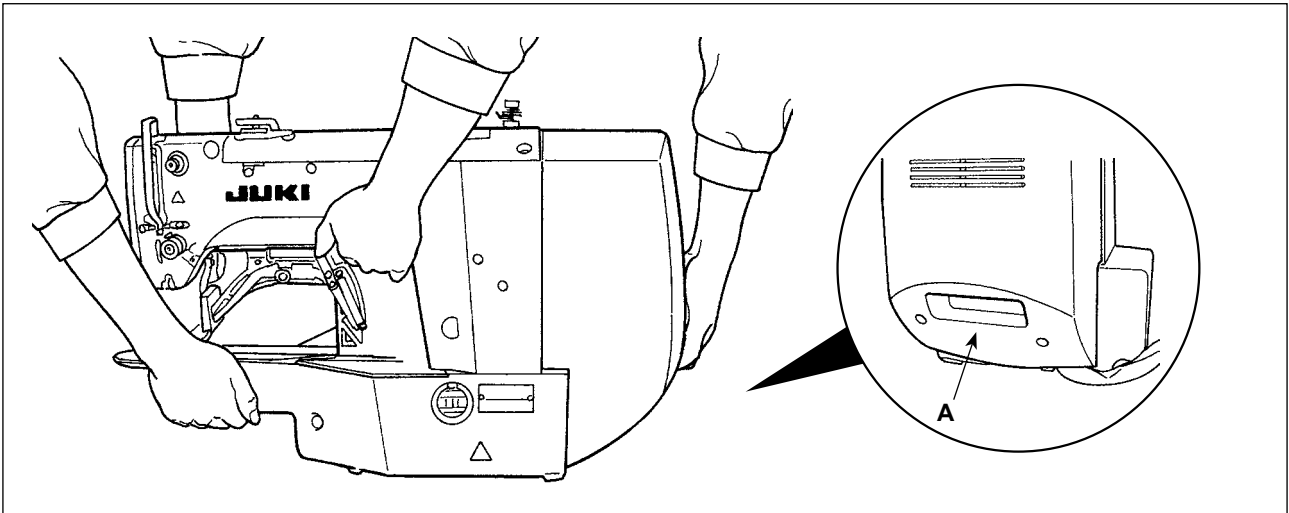

To carry the sewing machine, it is necessary to hold **A** section and support the side faces of the sewing machine by hand as illustrated in the figure.



1. Carefully prevent slippage of your hand that holds the cover.
2. The sewing machine weighs over 42 kg. Be sure to carry the sewing machine with two or more people without exceptions.
3. The LED light is installed to the undersurface of the frame. Do not hold the LED light when moving the frame.

3-7. Installation of the sewing machine head



WARNING :

To prevent possible accidents caused by the full of the sewing machine, perform the work by two persons or more when the machine is moved.

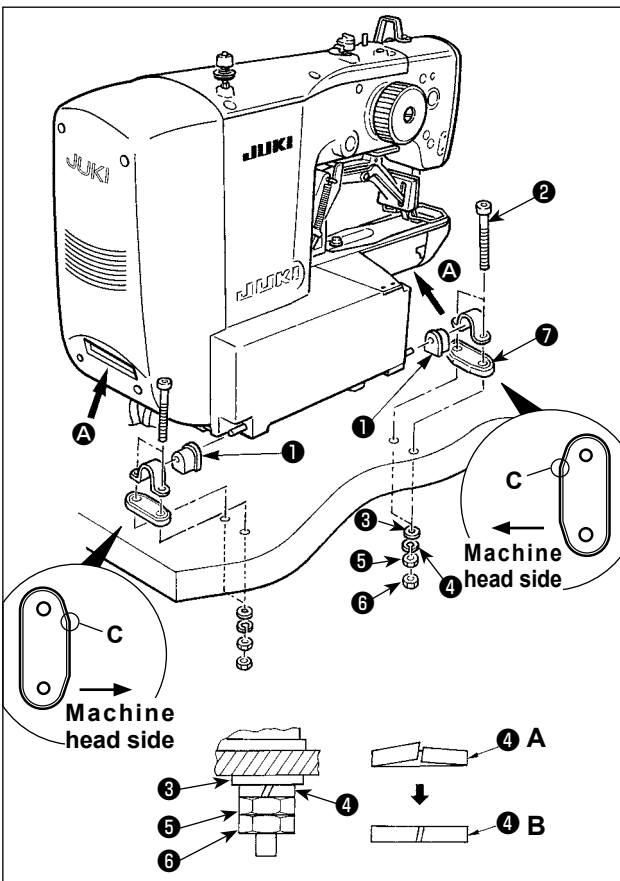

- 1) Fit hinge rubber cushion **1** over the hinge shaft.
- 2) Install the main body of the sewing machine on the table with four bolts **2**, four plain washers **3**, four spring washers **4**, four hexagonal nuts **5** and four hexagonal nuts **6**.



1. Tighten nut **5** until spring washer **4** is brought to the state as illustrated in Fig. B and fix the spring washer on hinge rubber **7** with nut **6**.
2. Mount hinge rubber **7** while orienting its corner section **C** toward the machine head side. Be aware that the hinge rubber fails to function properly if nuts **5** and **6** are excessively tightened.
3. When carrying the sewing machine, hold sections **A** with hands to support the side faces of the sewing machine.

3-8. Installing the drain receiver and the head support rubber

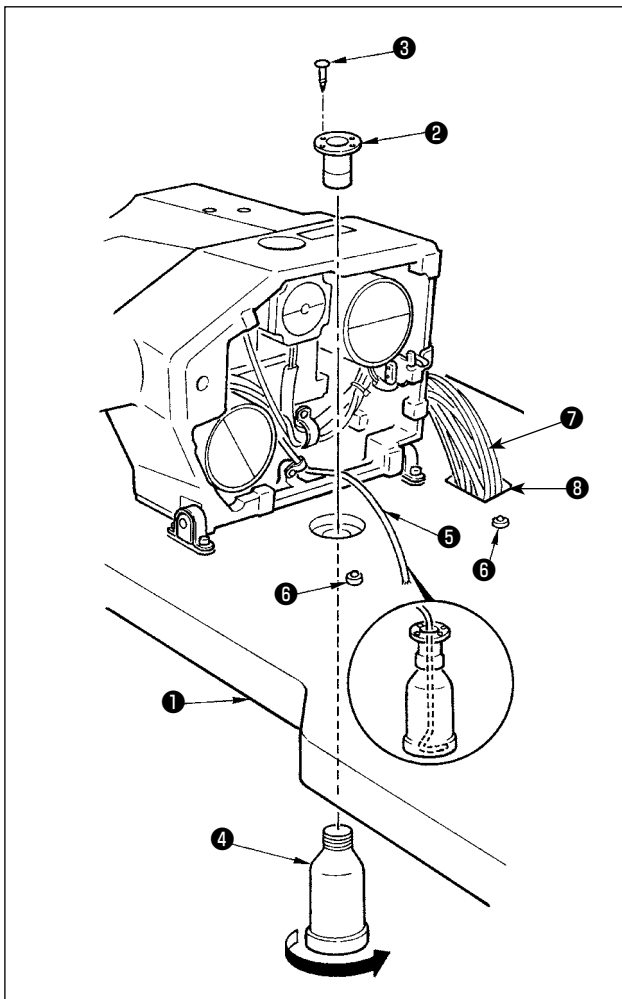

- 1) Fix drain receiver ② in the installing hole of table ① with two setscrews ③ .
- 2) Screw poly-oiler ④ in waste oil reservoir ② .
- 3) Insert sewing-machine waste oil pipe ⑤ into poly-oiler ④ .
- 4) Insert head support rubber ⑥ into table ① .
- 5) Pass bundle ⑦ of cords through slotted hole ⑧ in the table.



1. Insert drain pipe ⑤ until it will go no further so that it does not come off drain bin ④ when tilting the machine head.
2. Remove the tape fixing drain pipe ⑤ .

3-9. Safety switch



DANGER:

When using the safety switch without removing tape ① , it is very dangerous since the sewing machine works even in the state that it is tilted.

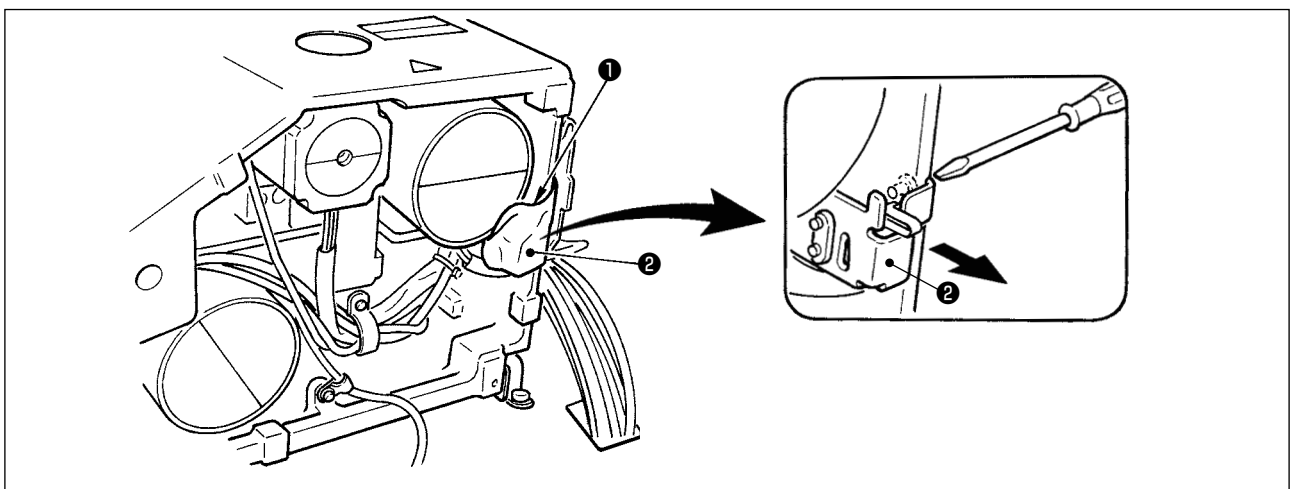

Remove tape ① fixing the lever section of safety switch ② .



In case error 302 occurs when the sewing machine works after setup, loosen the safety switch ② fitting screw with a screwdriver, and lower the switch to the downside of the sewing machine.

3-10. Tilting the sewing machine head



WARNING :

Tilt/raise the sewing machine head with both hands taking care not to allow your fingers to be caught in the head. Turn OFF the power before starting the work so as to prevent accidents caused by abrupt start of the sewing machine.

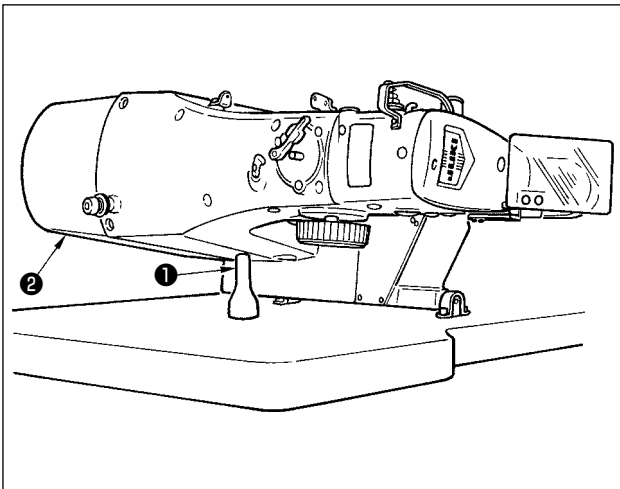

When tilting the sewing machine head, tilt the head gently until it comes in contact with head support rod ① .

① .

1. Before tilting the sewing machine head, make sure that head support rod ① is attached to the machine table.
2. When raising the sewing machine head, do not raise it while holding motor cover ② . It will be the cause of breakage of motor cover ② .
3. Be sure to tilt the sewing machine head on a flat place to prevent it from falling.



3-11. Installing the operation panel

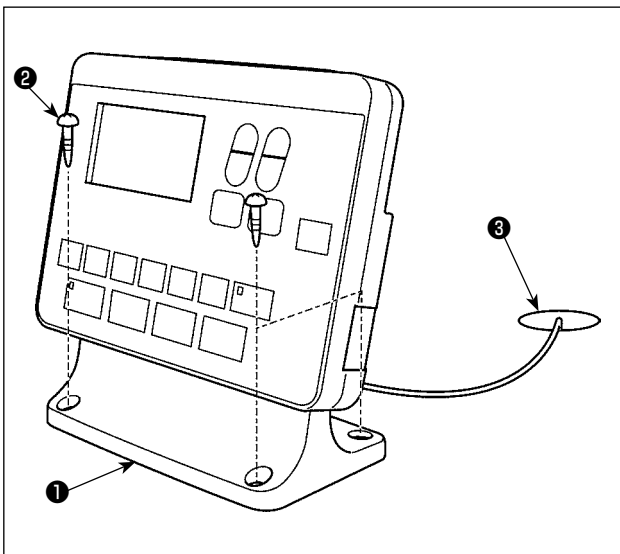

Fix operation panel mounting plate ① on the table with four wood screws ② . Then, pass the cable through hole ③ in the table.

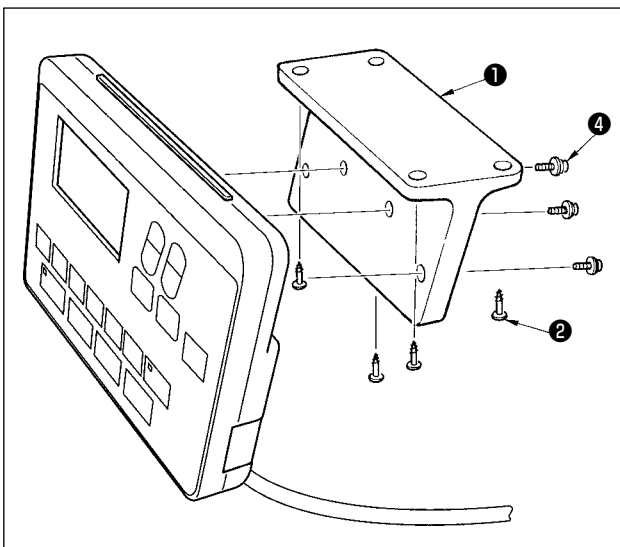

In the case of installing the operation panel on the underside of the table, install the operation panel on panel mounting plate ① by tightening screws ④ in four mounting holes. Then, fix the panel mounting plate at a desired position on the underside of the table with four wood screws ② .

3-12. Connecting the cords



DANGER :

To prevent personal injuries caused by electric shock hazards or abrupt start of the sewing machine, carry out the work after turning OFF the power switch and a lapse of 5 minutes or more. To prevent accidents caused by unaccustomed work or electric shock, request the electric expert or engineer of our dealers when adjusting the electrical components.

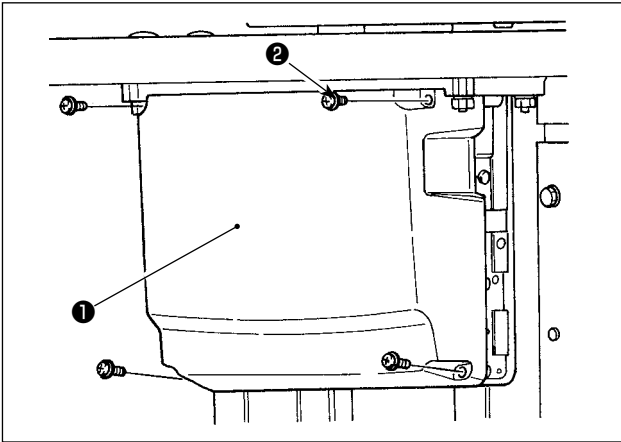

- 1) Loosen four setscrews ② of control box cover ①. Remove control box cover ①.
- 2) Connect the cords to the respective connectors on MAIN PWB, SDC PWB. (Fig. 1)
- 3) Fix the ground wire on position A of the control box with a screw. (Fig. 2)

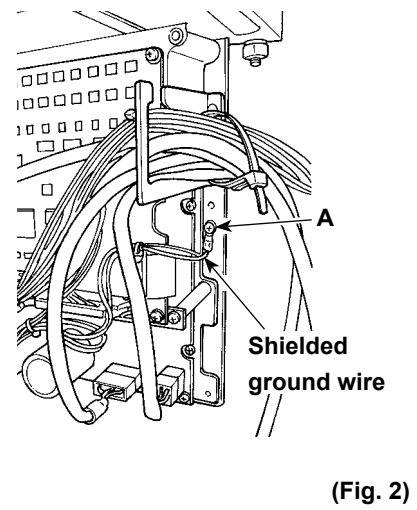
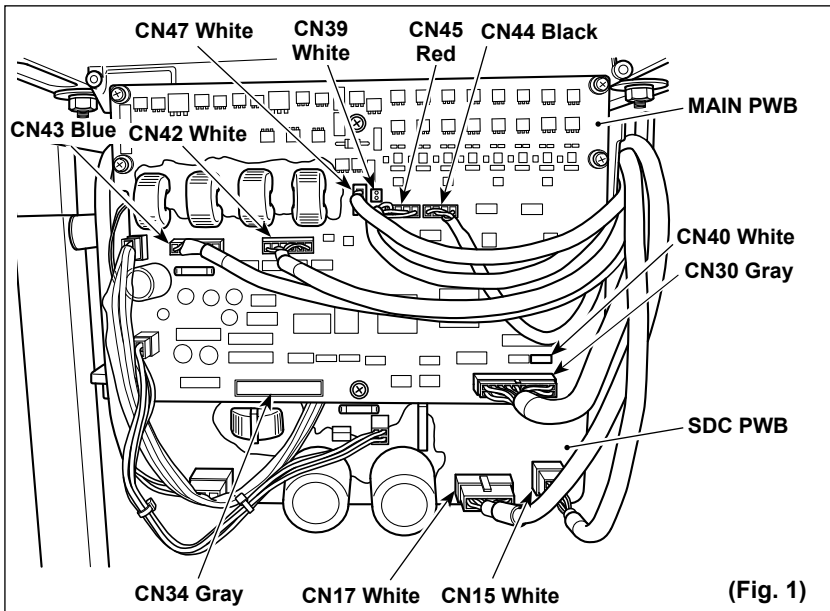
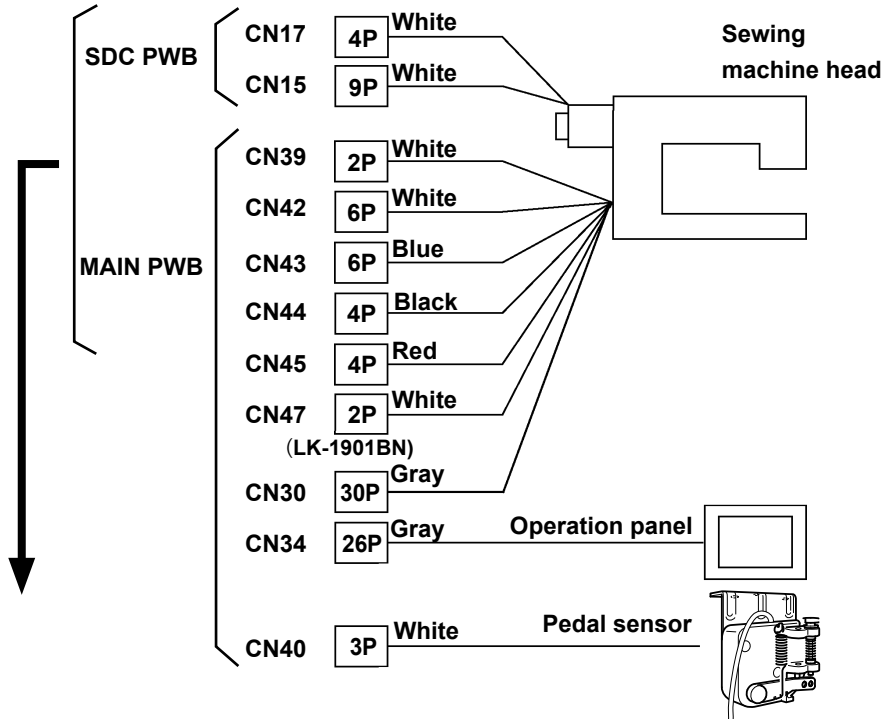

3-13. Handling the cords



DANGER :

To prevent personal injuries caused by electric shock hazards or abrupt start of the sewing machine, carry out the work after turning OFF the power switch and a lapse of 5 minutes or more. To prevent accidents caused by unaccustomed work or electric shock, request the electric expert or engineer of our dealers when adjusting the electrical components.

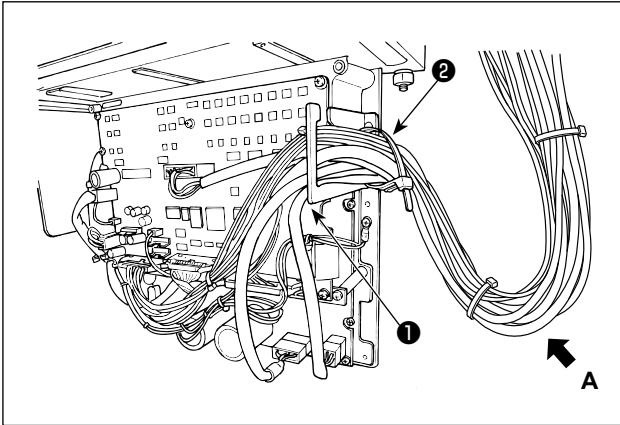

- 1) Bring the cords under the table into the control box.
- 2) Put the cord brought into the control box through cord exit plate ① and fix cable clip band ② .



Arrange the cord so that it is not tensed or hitched even when the machine head is tilted. (See A section)

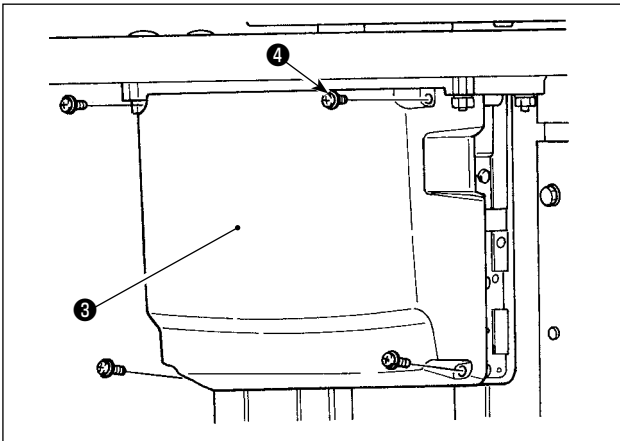

- 3) Install control box lid ③ with four setscrews ④ .

3-14. Installing the eye protection cover



WARNING :

Be sure to attach this cover to protect the eyes from the disperse of needle breakage.

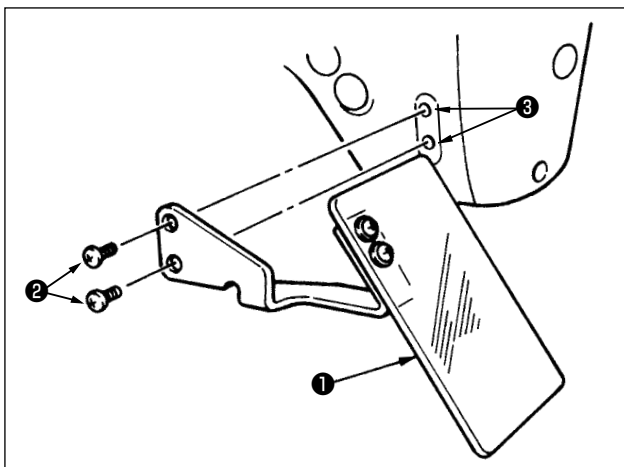

Be sure to use eye protection cover **1** after installing it on installing section **3** with screws **2** .

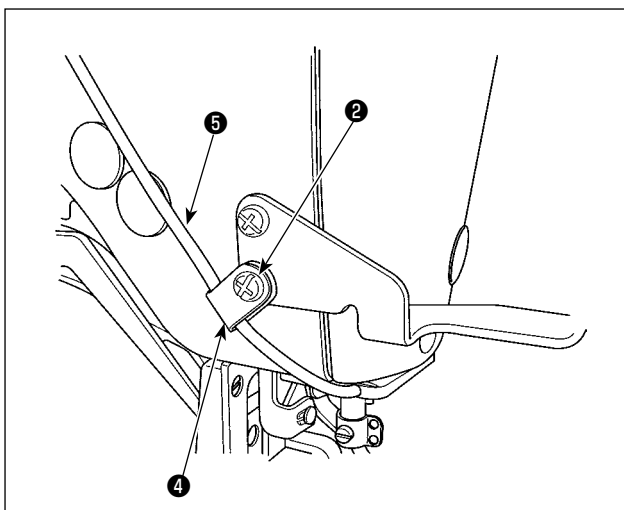

Pass LED cord **5** through accessory cord clamp **4** supplied with the unit as shown in the figure. Fix the LED cord with screw **2** located at the lower section of eye protection cover **1** .

3-15. Installing the thread stand

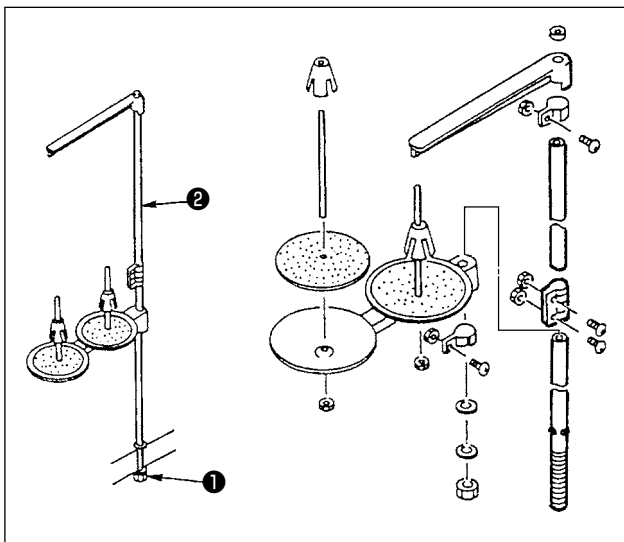

- 1) Assemble the thread stand unit, and insert it in the hole in the machine table.
- 2) Tighten locknut **1** to fix the thread stand.
- 3) For ceiling wiring, pass the power cord through spool rest rod **2**.

3-16. In the case the machine is transported after factory-completed at the time of shipment

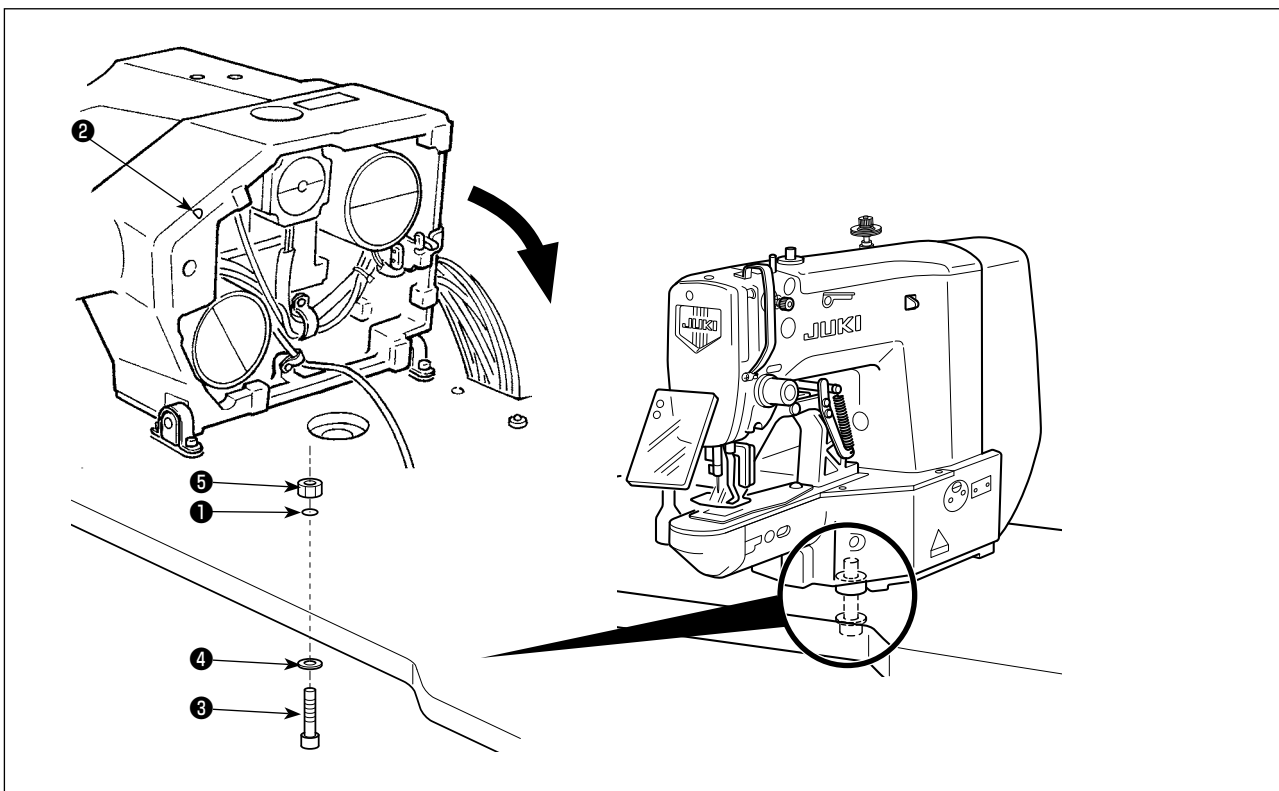

Pass bed fixing bolt **3**, plain washer **4** and nut **5** through hole **1** in the table and hole **2** in the sewing machine bed to fix the bed on the table.

4. OPERATION OF THE SEWING MACHINE

4-1. Lubrication



WARNING :

Turn OFF the power before starting the work so as to prevent accidents caused by abrupt start of the sewing machine.

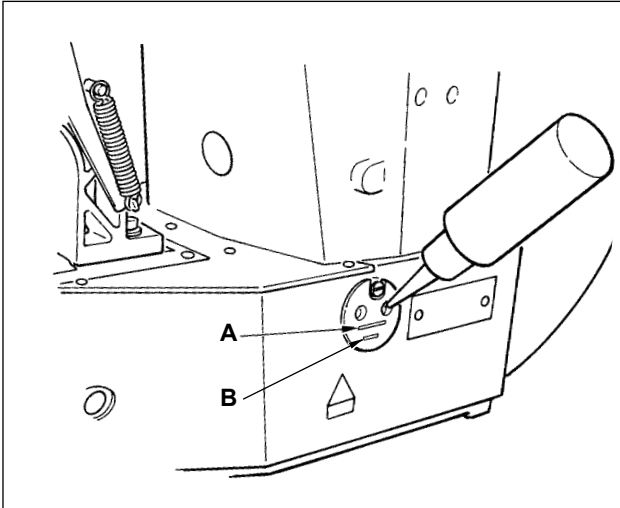

Check that the place between lower line **B** and upper line **A** is filled with oil. Fill there with oil using the oiler supplied with the machine as accessories when oil is short.

* The oil tank which is filled with oil is only for lubricating to the hook portion. It is possible to reduce the oil amount when the number of rotation used is low and the oil amount in the hook portion is excessive. (Refer to "[I.7-8. Amount of oil supplied to the hook](#)" p.53.)

1. Do not lubricate to the places other than the oil tank and the hook of Caution 2 below. Trouble of components will be caused.



2. When using the sewing machine for the first time or after an extended period of disuse, use the machine after lubricating a small amount of oil to the hook portion. (Refer to "[I.7-2. Adjusting the needle-to-shuttle relation](#)" p.50.)

4-2. Attaching the needle



WARNING :

Turn OFF the power before starting the work so as to prevent accidents caused by abrupt start of the sewing machine.

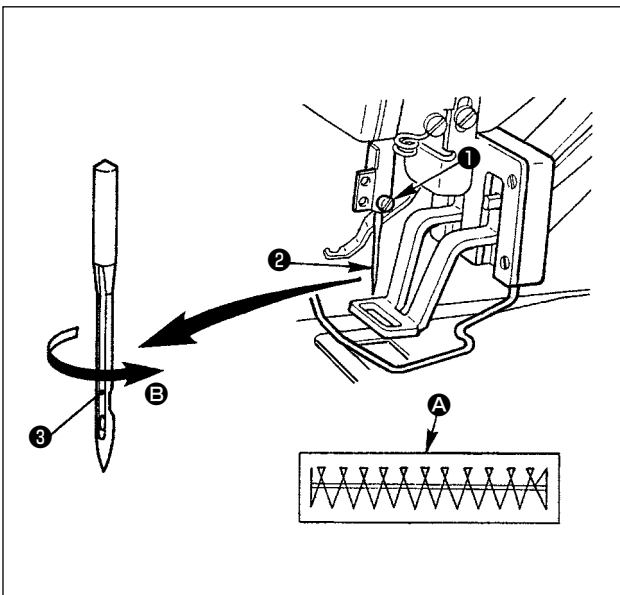

Loosen setscrew **1** and hold needle **2** with the long groove **3** facing toward you. Then fully insert it into the hole in the needle bar, and tighten setscrew **1**.



If the stitches are made as shown in **A**, attach the needle facing to the direction **B** to a small extent.

4-3. Threading the machine head



WARNING :

Turn OFF the power before starting the work so as to prevent accidents caused by abrupt start of the sewing machine.

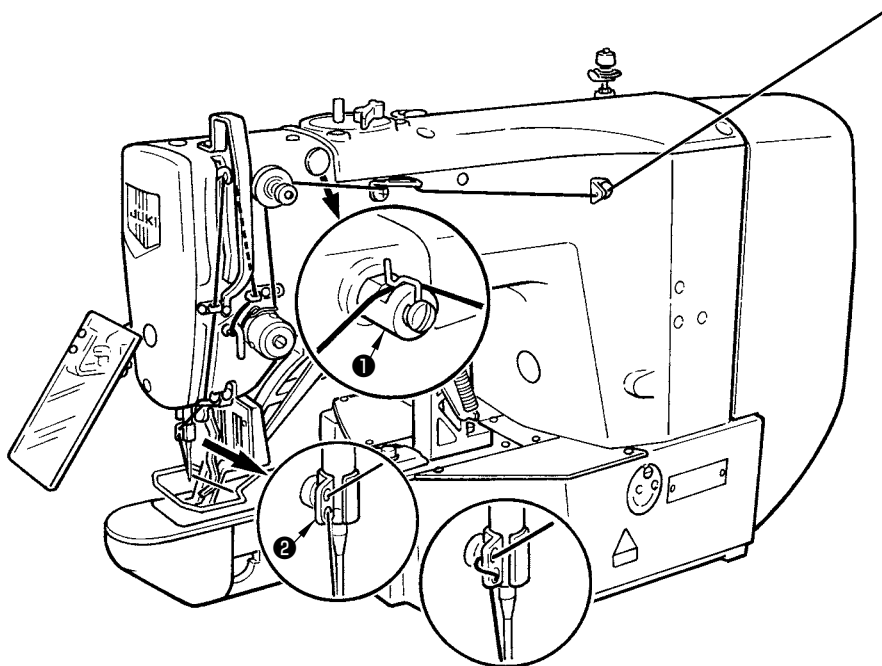

Thin filament thread or the like
1903BBNS sewing machine with the bird's nest preventing
and shorter-thread remaining type thread trimmer
(Polyester spun thread #80)

Pull out the thread by approximately 40 mm from the needle after threading through the needle.



1. When the silicon oil is used, thread through thread guide for silicon ① (Optional).
2. For thick thread, pass the thread through one hole only of needle bar thread guide ② .

4-4. Installing and removing the bobbin case



WARNING :

Turn OFF the power before starting the work so as to prevent accidents caused by abrupt start of the sewing machine.

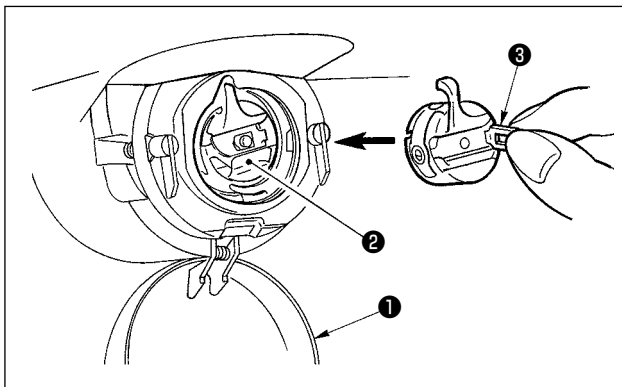

- 1) Open hook cover ① .
- 2) Raise latch ③ of bobbin case ② , and remove the bobbin case.
- 3) When installing the bobbin case, fully insert it into the shuttle shaft, and close the latch.



If it is not fully inserted, bobbin case ② may slip off during sewing.

4-5. Installing the bobbin



WARNING :

Turn OFF the power before starting the work so as to prevent accidents caused by abrupt start of the sewing machine.

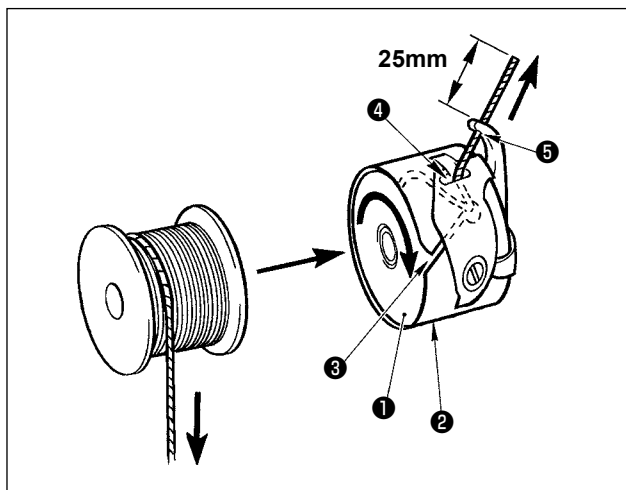

- 1) Set the bobbin ① into bobbin case ② in the direction shown in the figure.
- 2) Pass the thread through thread slit ③ of bobbin case ②, and pull the thread as it is. By so doing, the thread will pass under the tension spring and be pulled out from thread hole ④.
- 3) Pass the thread through thread hole ⑤ of the horn section, and pull out the thread by 25mm from the thread hole.



If the bobbin is installed in the bobbin case orienting the reverse direction, the bobbin thread pulling out will result in an inconsistent state.

4-6. Adjusting the thread tension

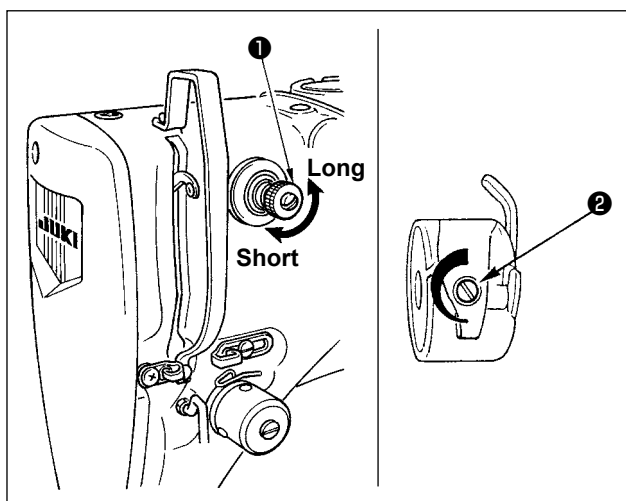

If thread tension controller No. 1 ① is turned clockwise, the length of remaining thread on the needle after thread trimming will be shorter. If it is turned counterclockwise, the length will be longer. Shorten the length to an extent that the thread is not slipped off.

Adjust needle thread tension from the operation panel and bobbin thread tension with ②.

Adjusting the needle thread tension

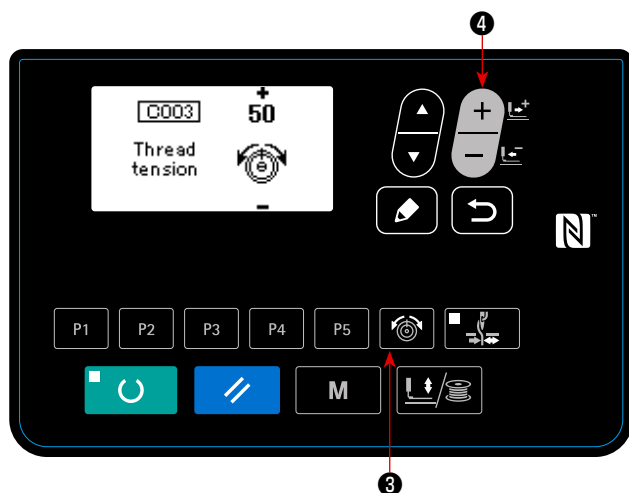

- 1) Press THREAD TENSION key ③ to display the thread tension input screen.
 - 2) Set a needle thread tension with DATA CHANGE key ④. The setting range is 0 to 200. Increasing the value increases the thread tension.
- * The sewing machine with standard specifications has been factory-set at 50 (the tension: 1.5 N when using spun thread #50) at the time of shipment. (When the thread tension No. 1 is opened.)

4-7. Adjusting the thread take-up spring

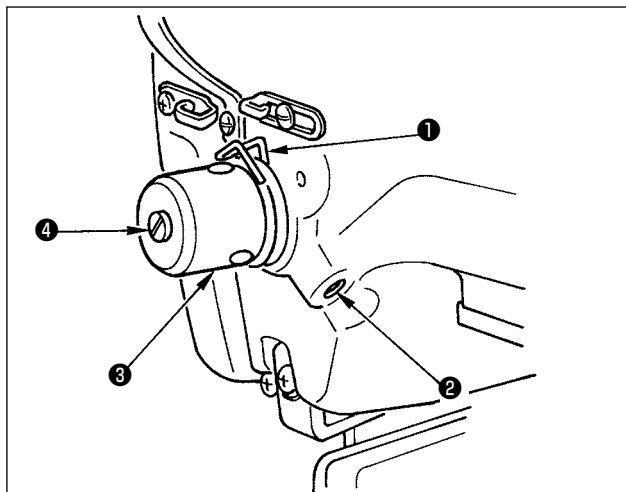

The standard stroke of thread take-up spring ① is 8 to 10 mm, and the pressure at the start is 0.1 to 0.3N.

1) Adjusting the stroke

Loosen setscrew ②, and turn thread tension asm. ③.

Turning it clockwise will increase the moving amount and the thread drawing amount will increase.

2) Adjusting the pressure

To change the pressure of the thread take-up spring, insert a thin screwdriver into the slot of thread tension post ④ while screw ② is tightened, and turn it. Turning it clockwise will increase the pressure of the thread take-up spring. Turning it counterclockwise will decrease the pressure.

4-8. Example of the thread tension

When using the sewing machine for the first time, adjust the thread tension referring to the table below.

Thread	Material	Needle thread tension setting	Thread take-up spring moving amount [Thread drawing amount]	Strength
Polyester filament thread #50	Wool	30 to 35	10mm [13mm]	0.1N
Polyester spun thread #50	Wool	50 to 55	10mm [13mm]	0.2N
Polyester spun thread #60 (Thread clamp OFF)	T/C broad	30 to 35	8 to 10mm [11 to 13mm]	0.1N
Cotton thread #50	Denim	35 to 45	10mm [13mm]	0.1N
Cotton thread #20	Denim	35 to 45	8 to 10mm [11 to 13mm]	0.1N

5. OPERATION OF THE SEWING MACHINE (BASIC)

Set each item following the procedure described below.

5-1. Selection of language

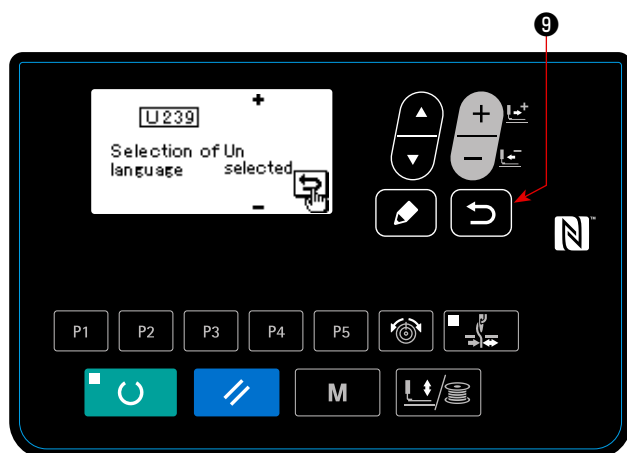

When you turn ON the power to the sewing machine for the first time after the purchase, the language selection screen is displayed. Select the language to be displayed, then press RETURN key  ⑨.

The language to be displayed on the screen can be changed by means of the memory switch U239 "Language selection". Refer to **"I.8. HOW TO USE THE MEMORY SWITCH"** p.56 for the details of the memory switch.

Caution If you terminate the language selection by pressing RETURN key  ⑨ without selecting the language, the language selection screen will be displayed every time you turn ON the power to the sewing machine.

5-2. Setting the pattern number

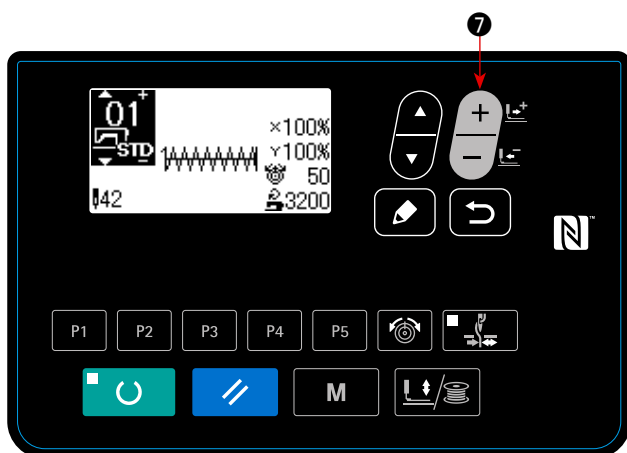

Turn ON the power switch.

Pattern number is displayed on the upper left section of the screen to indicate the pattern shape, X/Y enlargement/reduction ratios, thread tension value and sewing speed.

When you press DATA CHANGE key  7, the pattern number can be changed.



Refer the pattern No. to the separate table.

5-3. Setting the item data

When you press EDIT key  8, the item data input screen is displayed.

The items that can be edited are displayed on the left section of the screen and the set contents are displayed on the right section of the screen.

Select an item with ITEM SELECT key  6. Then, change the set content with DATA CHANGE key



(1) Inputting the X size

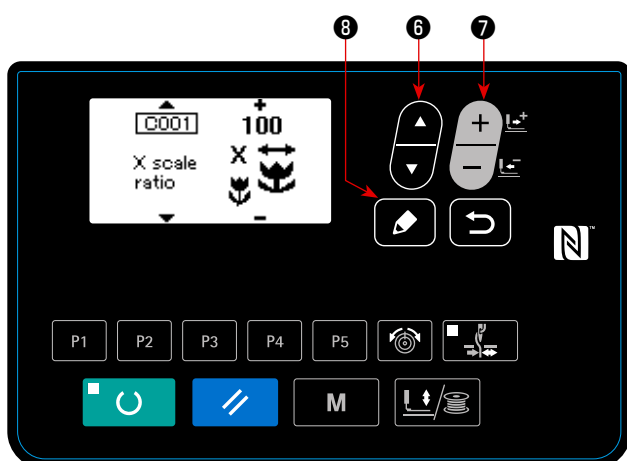

Press ITEM SELECT key  6 to display the C001 X size.

Press DATA CHANGE key  7 to display the value you desire.

One of the input method for the X/Y sizes can be selected; i.e., by inputting a percentage (%) with memory switch U064 or by inputting an actual value. (Initial value: Input in terms of percentage (%))



The setting exceeding 100% is dangerous since needle and the cloth presser interferes with each other and needle breakage or the like will occur.

(2) Inputting the Y size

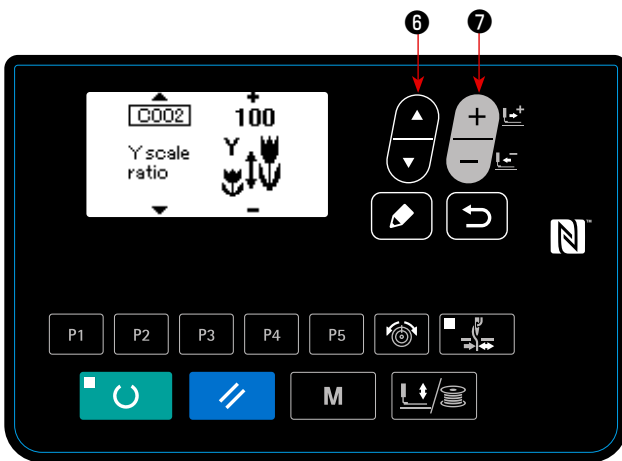

Press ITEM SELECT key  6 to display the C002 Y size.

Press DATA CHANGE key  7 to display the value you desire.

One of the input methods for the X/Y sizes can be selected; i.e., by inputting a percentage (%) with memory switch U064 or by inputting an actual value. (Initial value: Input in terms of percentage (%))

The setting exceeding 100% is dangerous since needle and the cloth presser interferes with each other and needle breakage or the like will occur.

(3) Inputting the sewing speed

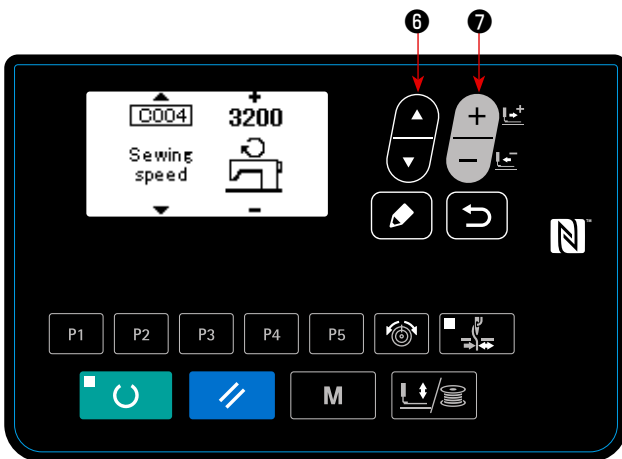

Press ITEM SELECT key  6 to display the C004 sewing speed.

Press DATA CHANGE key  7 to display the value you desire.

The maximum input range is the maximum sewing speed of the memory switch U001.

(4) Setting the comment

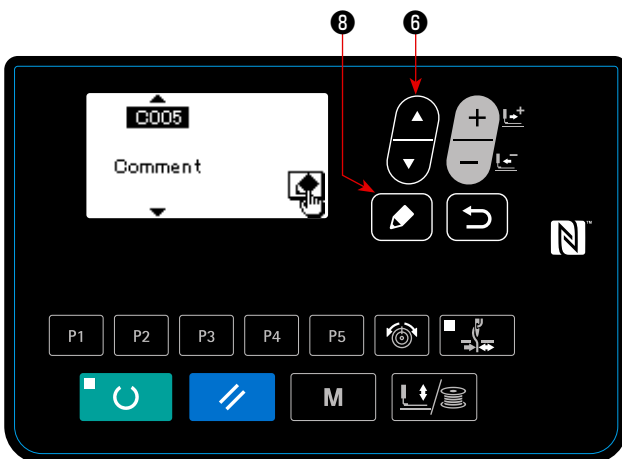



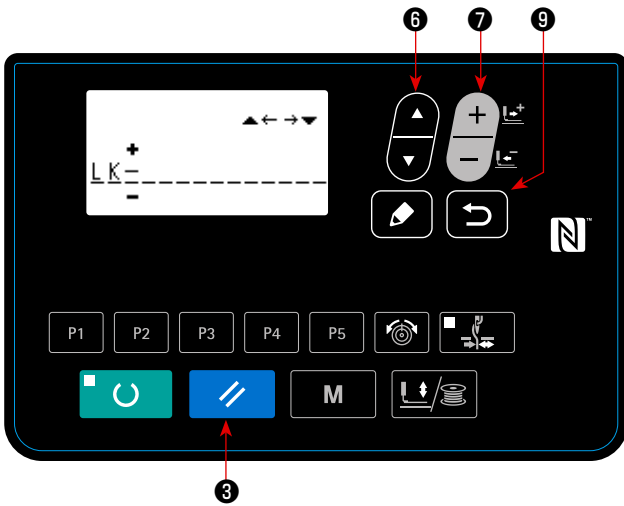

Press ITEM SELECT key  6 to display the C005 comment.

Press EDIT key  8 to display the comment input screen.



On the comment input screen, as many as 14 characters can be input. The characters that can be input are alphabets, numbers and symbols.

Press ITEM SELECT key  6 to specify the input position. Press DATA CHANGE key  7 to select the characters to be entered.

When you press RESET key  3, the character at the current input position is erased. When you keep RESET key  3 held pressed, all characters which have been input are erased.

After the completion of input of a comment, the screen is returned to the previous screen by pressing RETURN key  9.

(5) Setting the thread tension

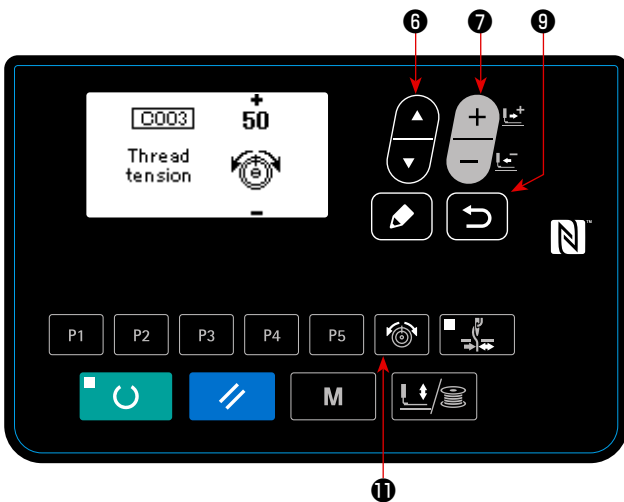

Press THREAD TENSION key  11 to display the C003 thread tension.

Press DATA CHANGE key  7 to display the value you desire. (Input range: 0 - 200)

After setting the sewing data, press RETURN key  9 to return to the input screen.

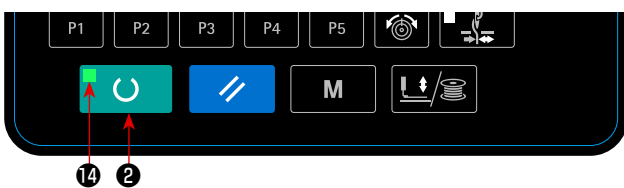

(6) Completing the setting



Press READY key  2.

The work clamp moves. Then, SET READY LED 14 lights up after the work clamp has gone up to enable sewing.

Caution When the presser is raised, be careful that fingers are not caught in the presser since the presser moves after having lowered.

- * When READY key  2 is pressed, the set values of pattern No., X/Y scale, etc. are memorized.
- * When READY key  2 is pressed, SET READY LED 14 goes out. Setting of each item can be changed.
- * The thread tension can be changed even when the SET READY 14 LED lights up. The thread tension is stored in memory with the start switch.
- * Check the pattern number before use. If you press READY key  2 with pattern number 0 displayed, error display E010 will be shown on the screen. At this time, re-set the pattern number.

Important When turning OFF the power without pressing READY key  2, the set values of pattern No., X/Y scale, number of max. rotation, and thread tension are not memorized.



5-4. Checking the contour of a sewing pattern

WARNING :

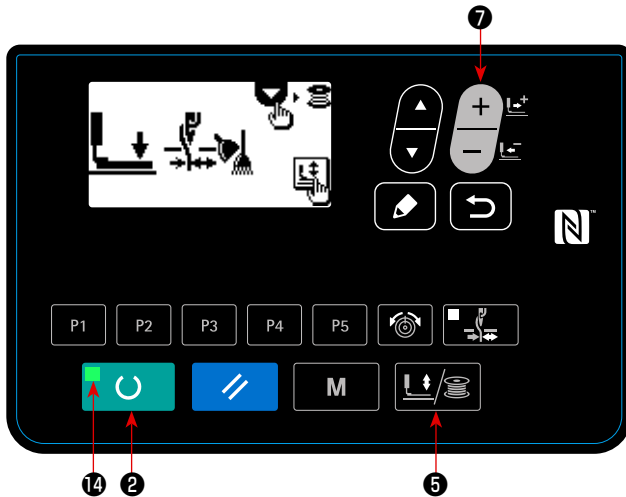

1. Make sure without fail of the contour of the sewing pattern after selection of the sewing pattern. If the sewing pattern extends outside the work clamp feet, the needle will interfere with the work clamp feet during sewing, causing dangerous troubles including needle breakage.
2. When making sure of the contour of the sewing pattern, press + / - key with the needle bar lowered, and the work clamp feet move after automatically making the needle bar return to the upper position.





- 1) Press READY key  (2) to light up the SET READY LED (14) .
- 2) Press work PRESSER and WINDER key  (5) to display "work clamp lowering screen".
- 3) Display the shape check screen with + key  (7) .

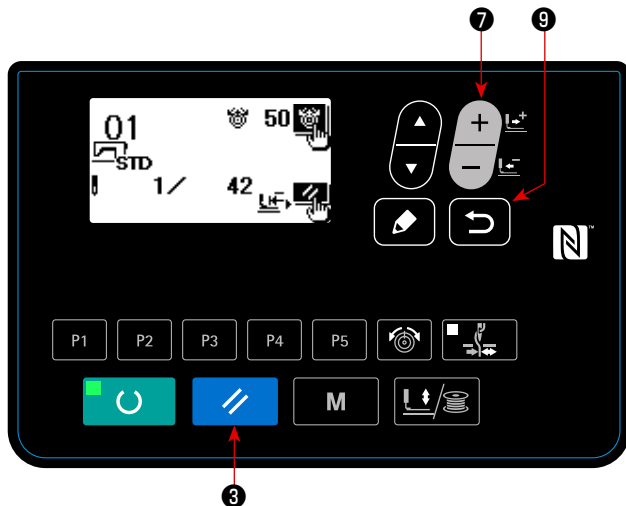

Under this mode, the sewing machine will not start running even if you depress the pedal.



- 4) Check the shape with DATA CHANGE key  (7) .
- 5) Press RESET key  (3) to return to the sewing starting position and lift the work clamp. When you press RETURN key  (9) , the sewing screen is displayed at the current position. When you depress the pedal in the aforementioned state, the sewing machine starts sewing from the current position.

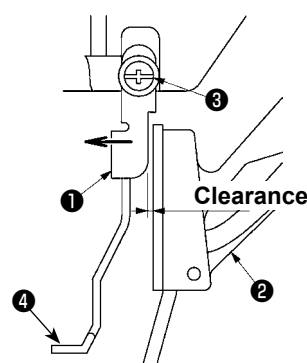
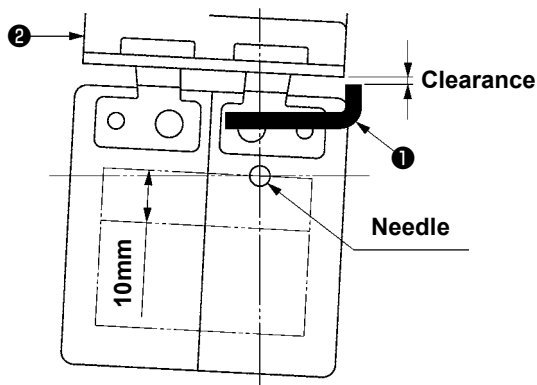

When using a sewing pattern which is full in lengthwise direction (+10 mm), make sure of the clearance between cloth feed base (2) and wiper base (1) . If there is no clearance, loosen setscrew (3) and move the wiper (4) to the needle side. Especially when the needle position comes to the rear on the right side, the clearance is decreased.

5-5. Sewing

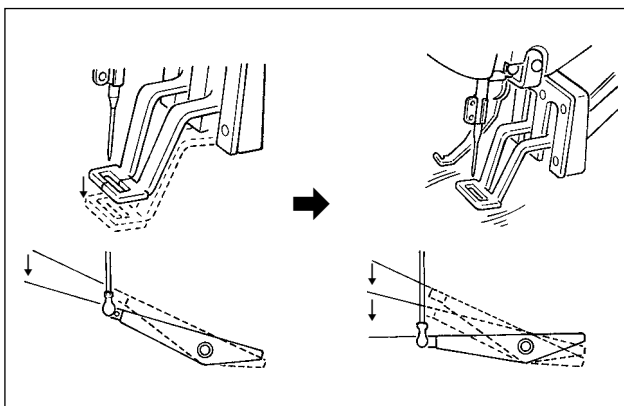

- 1) Set a workpiece on the work clamp foot section.
- 2) When you depress the pedal to the first step, the work clamp comes down. When you release the pedal, the work clamp goes up.
- 3) Depress the pedal switch to the second step after descending the work clamp feet at the first step, and the sewing machine will start sewing.
- 4) After the sewing machine completes sewing, the work clamp feet will go up, and return to the sewing start position.

5-6. Changing the pattern to a different one

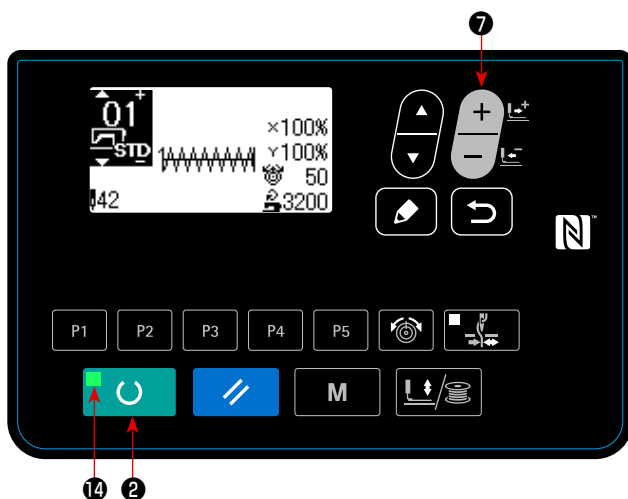

Press READY key  ② to turn off SET READY LED ⑭ .

Set a pattern number with DATA CHANGE key



Set the XY enlargement/reduction scale and speed as with "1.5-3. Setting the item data" p.18.

Press READY key  ② to light up SET READY LED ⑭ to enable sewing.



WARNING :

Make sure without fail of the contour of the sewing pattern after selection of the sewing pattern.

If the sewing pattern extends outside the work clamp feet, the needle will interfere with the work clamp feet during sewing, causing dangerous troubles including needle breakage.

5-7. Winding a bobbin

(1) To wind a bobbin while the sewing machine is performing sewing

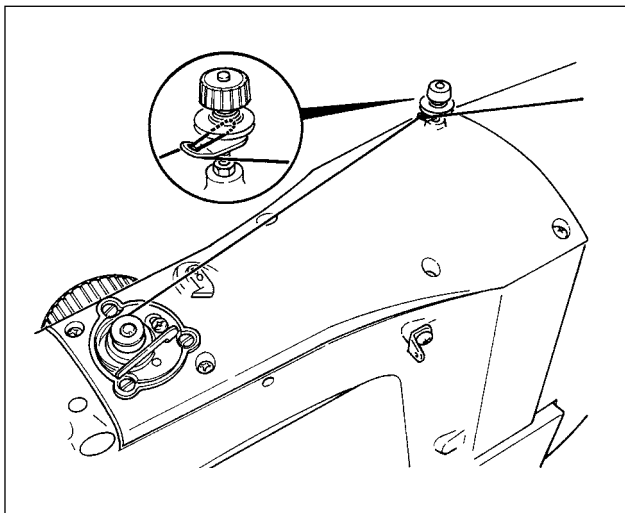

Thread the bobbin winder and wind the bobbin thread onto the bobbin as illustrated in the figure.

(2) For winding a bobbin only

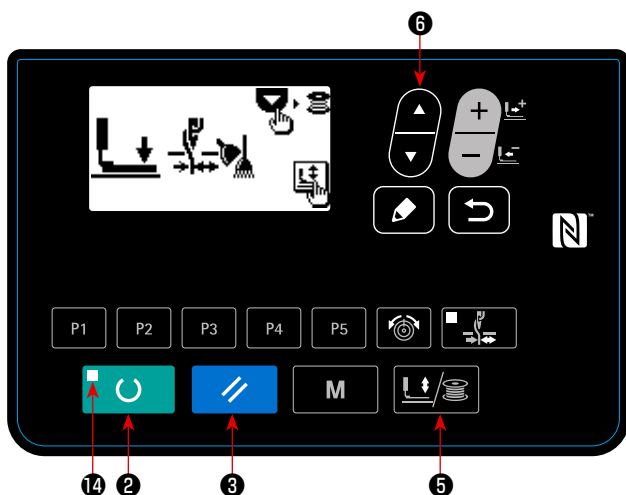

1) Press READY key  ② to turn off SET READY LED ⑭ .



2) Press work PRESSER and WINDER key  ③ and select lowering of the work clamp.

Caution Selection cannot be performed when the SET READY LED is lit up.

3) Press ▼ key  ⑥ . The bobbin winding screen is displayed.

4) When you depress the pedal, the sewing machine starts rotating.

5) Depress the pedal switch again or press RESET key  ③ to stop the sewing machine.

6) Press READY key  ② and RETURN key  ⑨ to exit from the bobbin winding screen.

Caution Bobbin winder does not work immediately after turning ON the power. Perform the bobbin winding after setting pattern No. or the like once, pressing the READY key  ② , and making the SET READY LED ⑭ light up.



For the LK-1903BN and LK-1903BN/BR35, wind the bobbin after removing the button and needle.

5-8. Thread clamp device

Trouble of sewing (slip-off of needle thread, stitch skipping, or stain of needle thread) at the time of high-speed start can be prevented with the thread clamp device. The thread clamp device works in the state that the thread clamp indication LED lights up and does not work when the LED goes off. Changeover of ON/OFF motion is performed with THREAD CLAMP key . When the thread clamp device is OFF, the start automatically becomes the slow start.



1. When memory switch No. 35 is "1" (prohibited), the thread clamp does not work. In addition, THREAD CLAMP key  is ineffective.
2. Memory switch, refer to "I.8. HOW TO USE THE MEMORY SWITCH" p.56.

* Matters that demand special attention when using the needle thread clamp device

- (1) In case of with the needle thread clamp (motion), make shorter the length of needle thread remaining on the needle at the sewing start for use. When the length of needle thread is lengthened, needle thread on the wrong side of material is apt to protrude. In addition, when the length is excessively lengthened, the end of needle thread held by the needle thread clamp may be rolled in the seams.

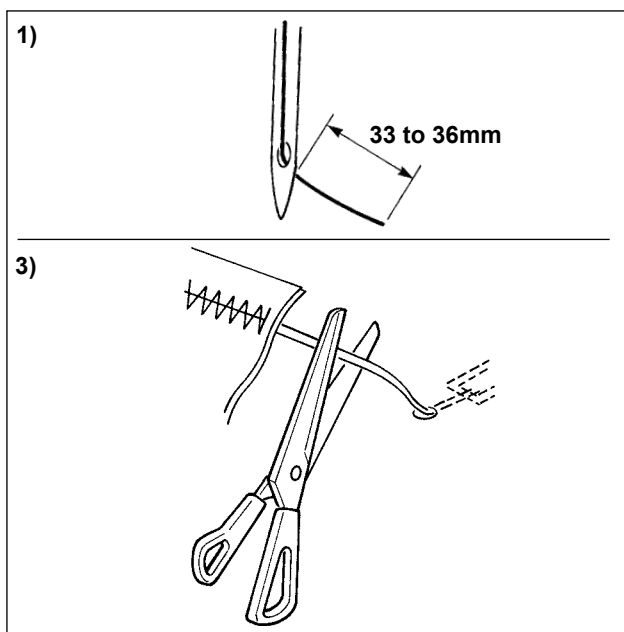

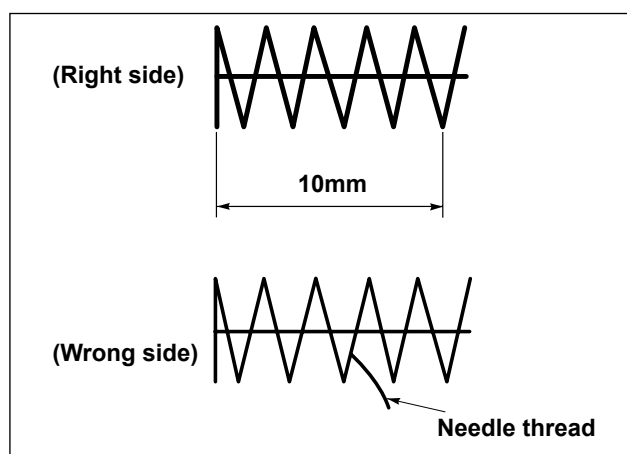

- 1) In case of with the needle thread clamp, the standard of the length of needle thread is 33 to 36 mm.
- 2) When needle thread is long after replacing thread or the like or sewing while holding needle thread by hand, turn OFF the THREAD CLAMP key .
- 3) When the needle thread held with the thread clamp is rolled in the seams, do not draw the material forcibly and cut the connecting needle thread with the scissors or the like. The seams are not damaged since it is the needle thread at the sewing start.

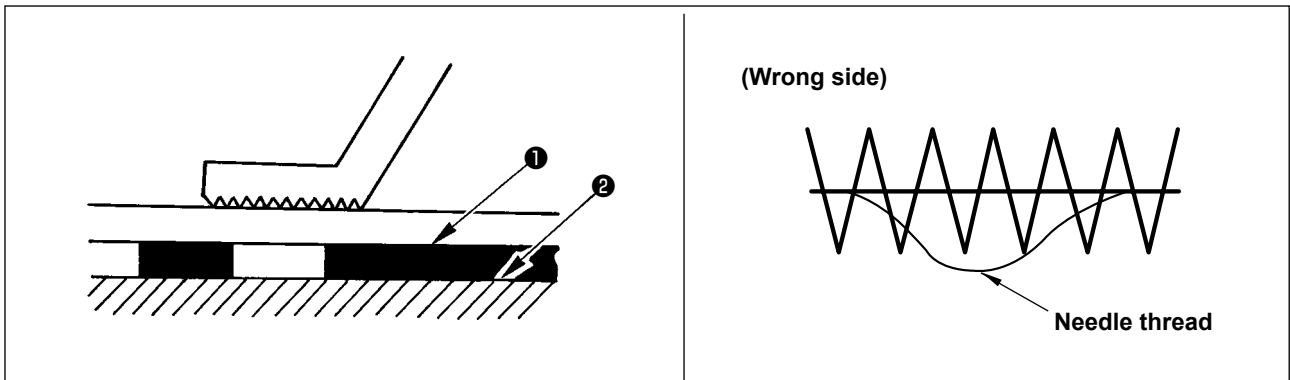

- (2) It is possible to adjust needle thread shorter by making the needle thread clamp work while holding the stabilized sewing at the start of sewing and the gathering (bird's nest) of needle thread on the wrong side of material can be lessened. However, for the pattern which the stitch length for neatly rolling in needle thread is short, needle thread may protrude from the wrong side of material. Select with/without thread clamp referring to the item below.
- 1) When the sewing length is short (less than approximately 10 mm), the end of needle thread may protrude like beard even when adjusting needle thread shorter.

(3) In the case feed plate ① which prevents the material from coming in close contact with throat plate ② is used, the needle thread which appears on the wrong side of the material can run off the seam regardless of the sewing length.



(4) For LK-1903BN (button sewing), the thread clamp is set to the motion prohibited in the state of standard delivery due to the aforementioned (2) and (3). For (memory switch No. 35) with cross-over stitch (, etc.) or X shape (, etc.), needle thread on the wrong side of material becomes easy to be rolled in. In this case, it is recommended to use the thread clamp.

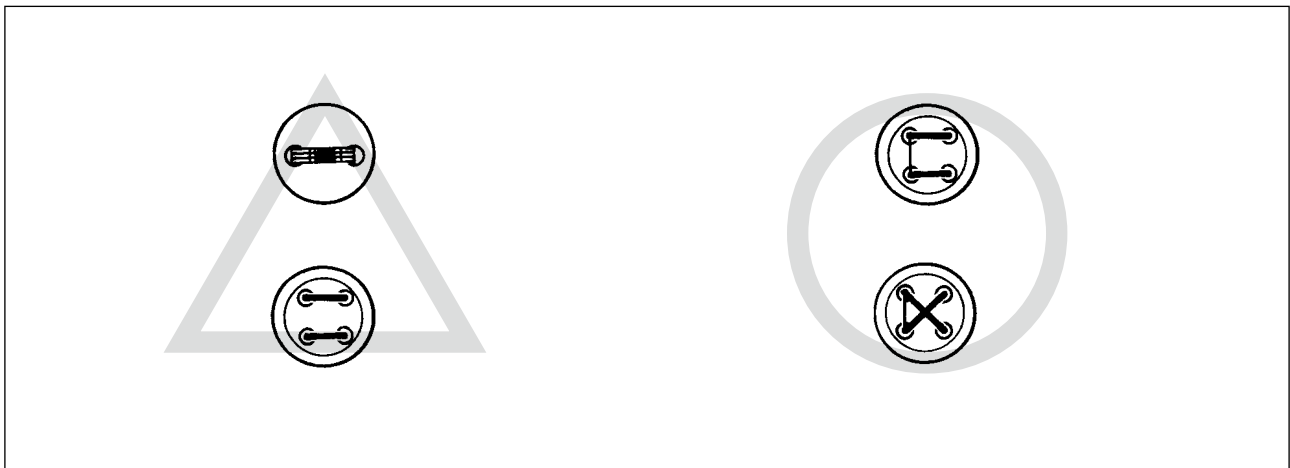

(5) When the thread clamp is used, and bobbin thread at the sewing start appears on the right side of material, reduce thread tension at the sewing start (2 to 3 stitches) and bobbin thread becomes less conspicuous.

[Example of setting] Tension of 1 to 2 stitches at the sewing start is “20” when sewing tension setting is “35”.

* For the setting of tension at the sewing start, refer to "[1.6-5. Setting the pattern thread tension](#)" p.39.

5-9. LED hand light



WARNING :

In order to protect against personal injury due to unexpected start of the sewing machine, never bring hands near the needle entry area or place foot on the pedal during the adjustment of intensity of the LED.

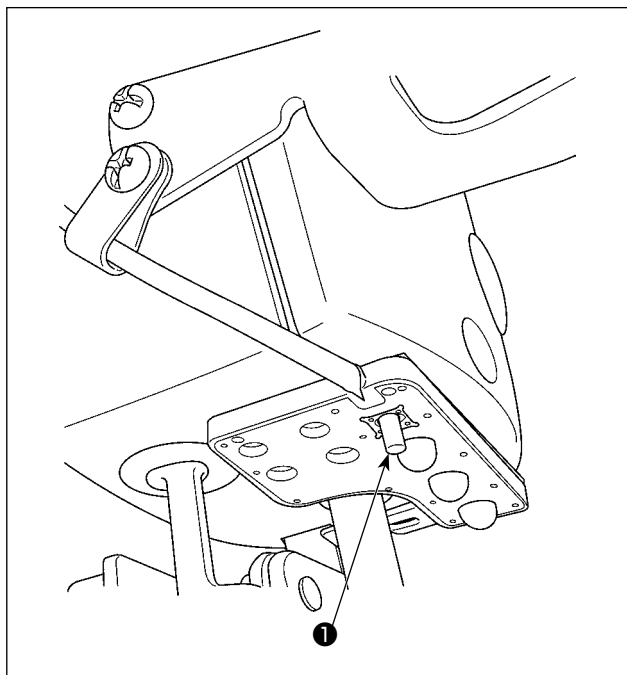

This LED is intended to improve operability of the sewing machine and is not intended for maintenance.



If the LED light is too bright when sewing a narrow sewing material or changing over the sewing material on the sewing machine, the LED light should be dimmed or turned OFF.

The sewing machine is provided as standard with an LED light which illuminates the needle entry area. Intensity adjustment and turn-off of the light is carried out by pressing switch ❶. Every time the switch is pressed, the light is adjusted in intensity in five steps and is turned off in turn.

[Change of intensity]

1 ⇒ 4 ⇒ 5 ⇒ 1
Bright ⇒ Dim ⇒ Off ⇒ Bright

In this way, every time the switch ❶ is pressed, the hand lamp status is changed in repetition.

6. OPERATION OF THE SEWING MACHINE (ADVANCED)

6-1. Performing sewing using the pattern keys

Patterns (No.1 to 200) which have been already registered can be registered to P1 to P50. It is possible to change and register the scale, max. speed limitation, thread tension and sewing position. Same as the patterns (No.1 to 200), P1 to P25 are used by the selection by scrolling the pattern Nos. The pattern calling from P1 to P25 can be made by one-touch as well.

* When selecting P6 to P25, perform the selection by combination (simultaneous pressing) of **P1**

P2 **P3** **P4** and **P5** keys as shown in the table below.

P-No.	Selection key	P-No.	Selection key	P-No.	Selection key	P-No.	Selection key
P1	P1	P8	P1+P4	P15	P4+P5	P22	P2+P3+P4
P2	P2	P9	P1+P5	P16	P1+P2+P3	P23	P2+P3+P5
P3	P3	P10	P2+P3	P17	P1+P2+P4	P24	P2+P4+P5
P4	P4	P11	P2+P4	P18	P1+P2+P5	P25	P3+P4+P5
P5	P5	P12	P2+P5	P19	P1+P3+P4		
P6	P1+P2	P13	P3+P4	P20	P1+P3+P5		
P7	P1+P3	P14	P3+P5	P21	P1+P4+P5		

(1) Register to the pattern key

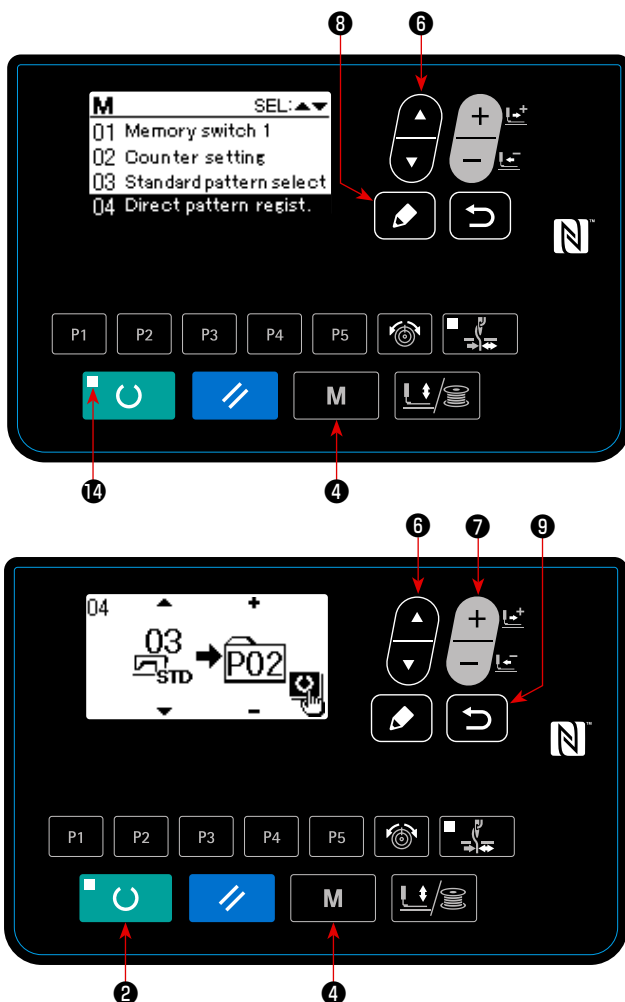

Setting example : Register following setting to the P2., Pattern No. 3, X scale rate : 50%, Y Scale rate : 80%, Max. speed limitation : 2,000 sti/min, Thread tension : "50", Pattern position : 0.5 mm to the right and 1 mm to the front



1) Turn ON the power switch and press MODE key **M** (4) to enter mode setting (memory switch setting). (SET READY LED (14) should be put out.)

Press ITEM SELECT key  (6) to select "04 Direct pattern regist".

Press EDIT key  (8) to display the pattern registration mode.

2) Press ITEM SELECT key  (6) to set the standard pattern to No. 3. Press DATA CHANGE key  (7) to set P-No. to 2.

When you press the READY key  (2), P2 is registered and the mode screen is displayed.

Press MODE key **M** (4) or RETURN key  (9).

* When the select key is held pressed for one second in the state where the standard pattern or user pattern is selected on the data input screen, this screen can be displayed.

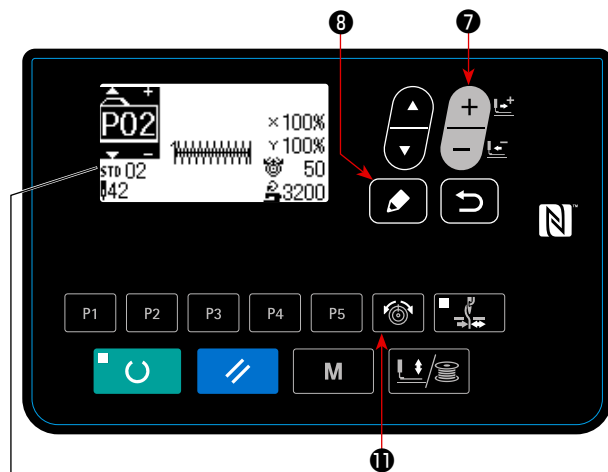

3) Press EDIT key  8 . Edit the item data with DATA CHANGE key  7 .

The item data that can be edited are as described in "(2) Listing of item data" p.30 .

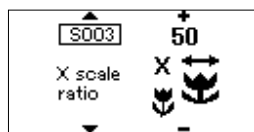

4) Respectively set the X reduction ratio to "50" (%), Y reduction ratio to "80" (%), sewing speed to "2000" (sti/min) and thread tension to "50".

* Press thread tension key  11 to display "S005" and set the thread tension.

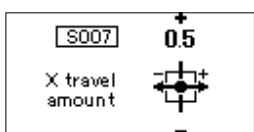
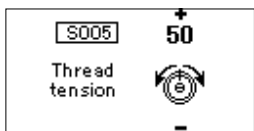
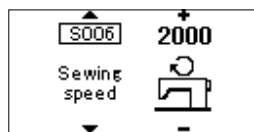
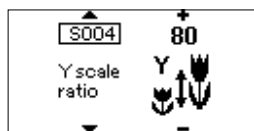

5) The "X enlargement/reduction ratio" display 0.0 is displayed by pressing EDIT key  8 .

The amount of travel in X direction can be set in increments of 0.1 mm. Change the set value to

"0.5" with DATA CHANGE key  7 .



6) The "Y enlargement/reduction ratio" display 0.0 is displayed by pressing EDIT key  8 .

The amount of travel in Y direction can be set in increments of 0.1 mm. Change the set value to

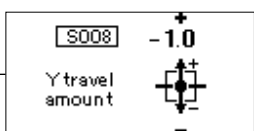

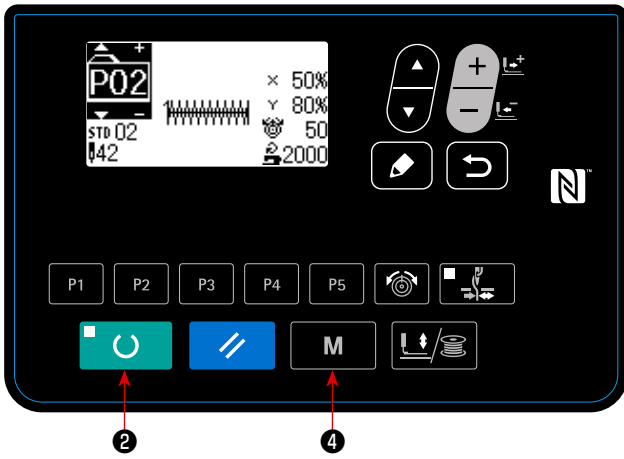







"-1.0" with DATA CHANGE key  7 .





- 7) Press READY key  ② , key to finalize the setting.
- 8) Press MODE key  ④ .
Pattern register mode is finalized.
- 9) Press MODE key  ④ .
Mode setting is finalized and the mode returns to the normal mode.

(2) Listing of item data

No.	Item name	Pictograph	Input range	Remarks:
S001	Type of pattern		Standard pattern / User pattern	* This data is for display only. To edit the data, delete the direct pattern and create a new direct pattern.
S002	Pattern No.		Standard pattern : 1 to 51 User pattern : 1 to 200	* This data is for display only. To edit the data, delete the direct pattern and create a new direct pattern.
S003	X enlargement/ reduction scale/ actual dimension		When inputting in terms of percentage (%): 20 - 200 % When inputting an actual dimension: Within the range of actual dimensions corresponding to the percentage	Input method (percentage or actual dimension) can be selected by setting the memory switch U064. (Initial value: Input in percentage)
S004	Y enlargement/ reduction scale/ actual dimension		When inputting in terms of percentage (%): 20 - 200 % When inputting an actual dimension: Within the range of actual dimensions corresponding to the percentage	Input method (percentage or actual dimension) can be selected by setting the memory switch U064. (Initial value: Input in percentage)
S005	Thread tension		0 to 200	Directly specify the thread tension with the THREAD TENSION key. The thread tension cannot be selected with ▼▲ key.
S006	Sewing speed		400 to 3200	The maximum input range depends on the maximum sewing speed set with the memory switch U001.
S007	X travel amount		- 20 to 20	
S008	Y travel amount		- 20 to 10	
S009	2-step stroke work clamp stroke height		50 to 90	Display/hide of the stroke height can be selected using the memory switch U069. (Initial value: Hide) When the hide is selected, the stroke height is not displayed on the data edit screen.
S010	Position of the last stitch X travel amount		- 2.0 to 2.0	Display/hide of the stroke height can be selected using the memory switch U070. (Initial value: Hide) When the hide is selected, the stroke height is not displayed on the data edit screen.
S011	Position of the last stitch Y travel amount		- 2.0 to 2.0	Display/hide of the stroke height can be selected using the memory switch U070. (Initial value: Hide) When the hide is selected, the stroke height is not displayed on the data edit screen.
S012	Comment		The number of characters that can be input: 14	

(3) Sewing operation

Operation example : After performing sewing with the contents of the registered P2, perform sewing with the contents of P3.

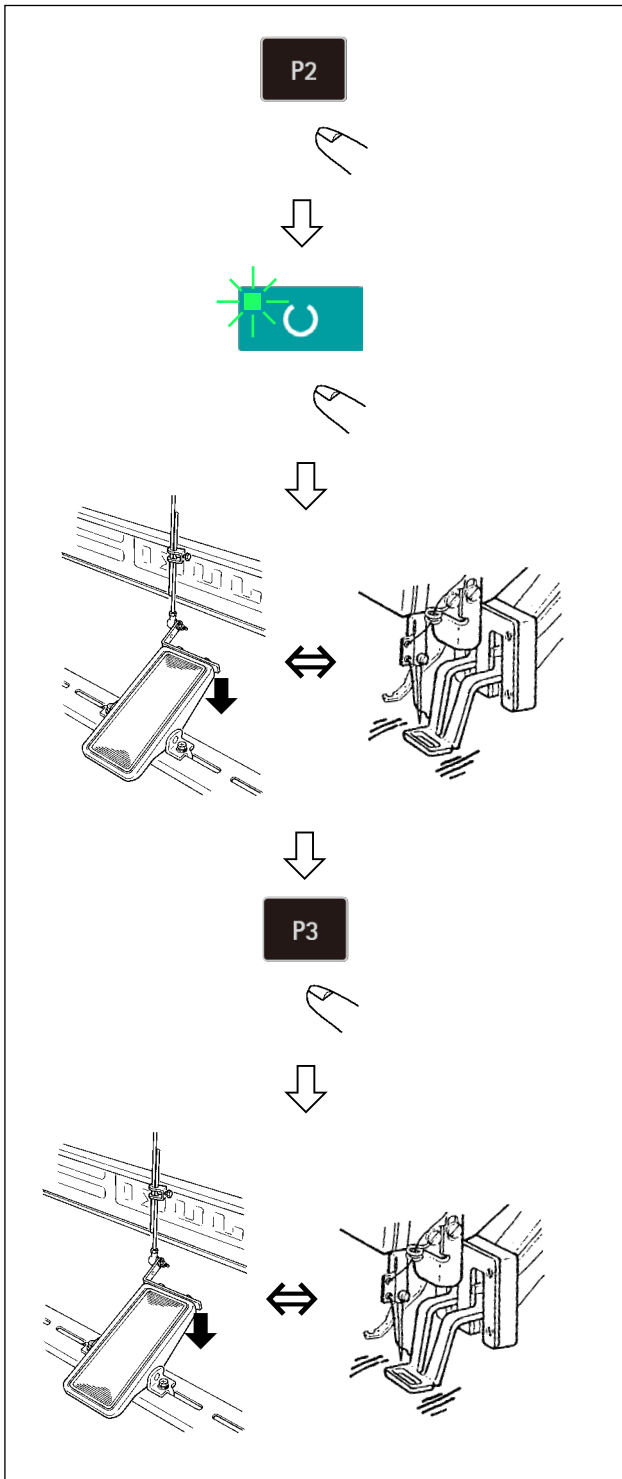

- 1) Turn ON the power switch.
- 2) Press direct pattern **P2**.
- 3) Press READY key  to light up SET READY LED. Once the LED lights up, the work clamp goes up after traveling.
- 4) Check the contour of the sewing pattern.
(Refer to the item "1.5-4. Checking the contour of a sewing pattern" p.21.)
- 5) If the contour of the sewing pattern is acceptable, the sewing can be made.
- 6) After the completion of sewing, press direct pattern **P3**. Then, the work clamp comes down, retrieves the origin, travels to the sewing starting point and goes up. Then, the origin is retrieved. After the origin retrieval, the work clamp travels to the sewing starting point and goes up. (The P keys can operate the pattern change by one-touch even when the SET READY LED is lighting up.)
- 7) Perform the above items 4) and 5).

* P1 to P25 can be specified by selecting the pattern. Display the target pattern using DATA

CHANGE key .

→ 0 to 200 ↔ P1 to 25 ←

P1 to P25 which have not been registered are not indicated.

Caution Press P1 to P25 key while the SET READY LED lights up and the presser comes down. Be careful that your fingers are not caught in the presser.

Pattern register from P26 to P50 can be performed. Register can not be performed in **P1** to **P5** key. Designate the pattern by the pattern selection only. Indicate the

Reference pattern with  key.

→ 0 to 200 ↔ P1 to P25 ↔ P26 to P50 ←

Pattern selection from P26 to P50 cannot be performed while the SET READY LED lights up.

6-2. Sewing using the combination function (cycle sewing)

This sewing machine can perform sewing of plural sewing pattern data in one cycle in the order of the data. As many as 99 patterns can be input. Use this function for sewing two or more different patterns on the sewing product. In addition, registration of as many as 99 cycles can be performed. Copy and use the data to fill the needs.

→ Refer to "1.6-6. Copying or deleting various kinds of pattern data" p.40

(1) Selection of cycle data

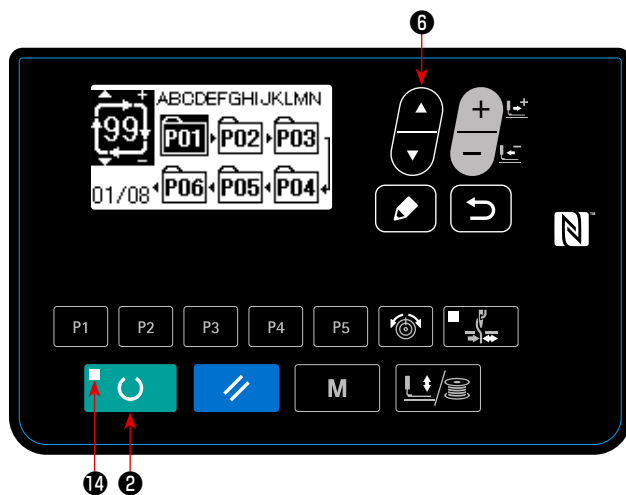

1) Set the mode to the input mode.

Under the input mode where SET READY LED 14 goes out, selection of the cycle data is enabled.

If the current mode is the sewing mode, press READY key  2 to change over the mode to the input mode.

Only under the input mode, selection of the cycle data is enabled.

2) Select cycle stitching data.

Press ITEM SELECT key  6, and pat-

terns which have been registered are changed over and displayed in order. Cycle data No. and continuous stitching data No. which have been registered after the last registered pattern No. are displayed. Here, select the cycle data No. which you desire to sew.

3) Perform sewing.

When READY key  2 is pressed in the state where the cycle data is selected, SET READY LED 14 lights up to show that the sewing is enabled.

Cycle data No. 1 only has been registered at the time of your purchase. However, sewing status cannot be obtained since the sewing pattern has not been inputted. Perform inputting of sewing pattern referring to (2) Method of editing cycle data on the next page.

(2) Method of editing cycle data

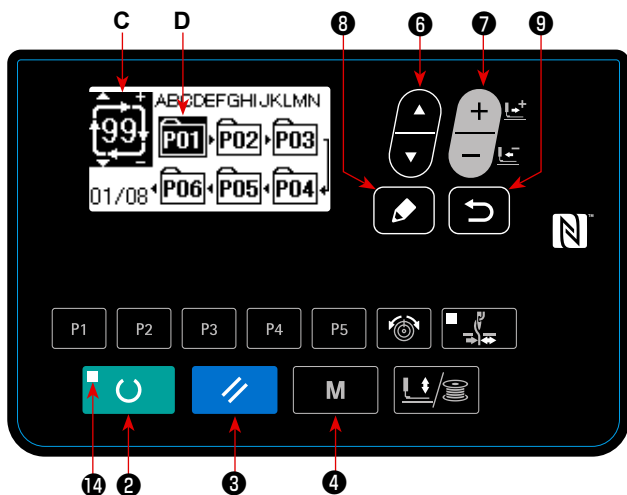

1) Set the mode to input mode.

Under the input mode where SET READY LED 14 goes out, entry of the cycle data is enabled. If the current mode is the sewing mode, press READY key 2 to change over the mode to the input mode.

2) Set cycle data to editing status.

When EDIT key 8 is pressed, the cycle data editing display C appears on the screen. The pattern No. D to be sewn is displayed in reverse video. In this state, it is possible to edit the data.

3) Selecting the edit point

When you press ITEM SELECT key 6, the edit point is changed and the current point is displayed in reverse video. When you move the edit point forward until the last point is reached, additional indication pictograph  is displayed.

When you press EDIT key 8 while selecting the edit point, the additional indication pictograph  is displayed at the selected position to enable insertion of pattern data.

4) Change data of selected editing point.

Press DATA CHANGE key 7 and data of editing point can be changed.

Pattern No. which has been registered is displayed and it is possible to select.

In addition, press RESET key 3, and the pattern data of editing point can be deleted.

When RESET key 3 is held pressed for one second, all the registered pattern data can be deleted.

Repeat steps 3) and 4) to perform editing data.

5) Cancelling insertion of pattern data

Insertion of the pattern data is cancelled and the mode is changed over to the input mode by pressing RETURN key 9.

(3) Sewing operation

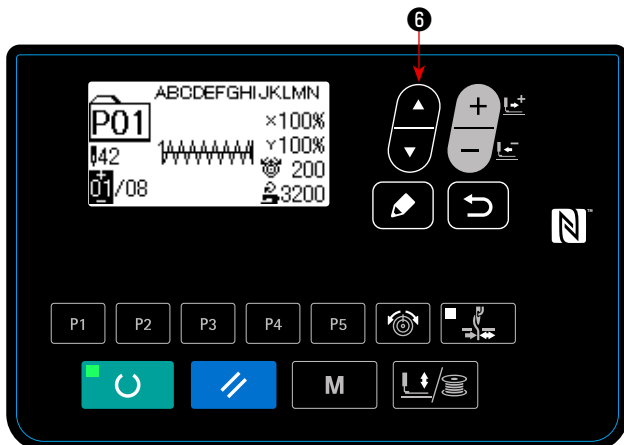
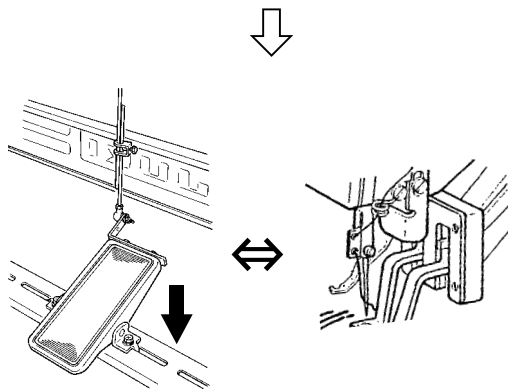

- 1) Turn the power ON.
- 2) Select the cycle pattern using ITEM SELECT key



6 . Select the cycle pattern number with

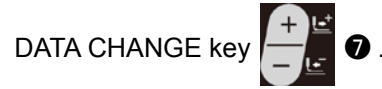

DATA CHANGE key 7 .

- 3) Press READY key  2 to light up SET READY LED 14 . Then, the work clamp goes up after travelling.

- 4) If the pattern shape is correct, start sewing.

- 5) The step of pattern numbers combined on a sewing-by-sewing basis advances until one cycle is completed. After the completion of the cycle, the sewing machine returns to the first step of the cycle to permit sewing in repetition.

* When you want to return to the previous pattern after the completion of sewing or to skip the next

pattern, press DATA CHANGE key  7

while SET READY LED 14 lights up.

The pattern display changes and the work clamp travels to the sewing starting point.

* Be aware that the contents of P1 to P50 used for C1 to C99 will be changed if you change the contents of P1 to P50 after the registration of C1 to C99.

* Check the pattern shape on a pattern-by-pattern basis. (Refer to ["I.5-4. Checking the contour of a sewing pattern" p.21.](#))

* When you press ITEM SELECT key  6 on

the sewing screen, the details of the pattern to be sewn can be displayed.

6-3. Sewing through the use of the counter

(1) Setting procedure of the counter value

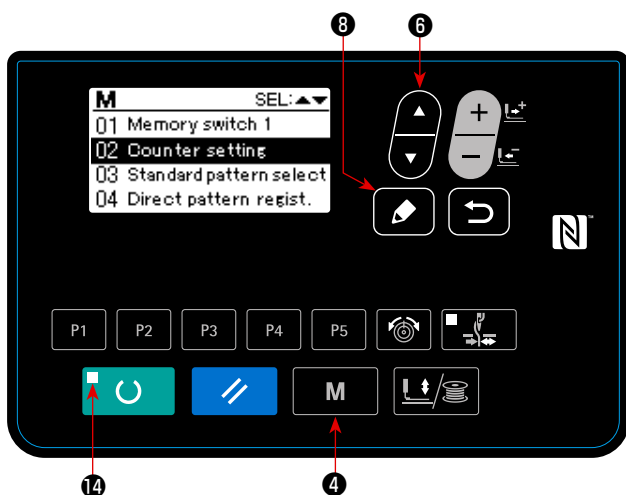

1) Call counter setting screen.

Press MODE key **M** ④, in the state where SET READY LED ⑭ goes out, to display the mode screen.

Place "02 Counter setting" in the selected state

with ITEM SELECT key  ⑥. Press EDIT key

EDIT key  ⑧ to display the counter screen

A.

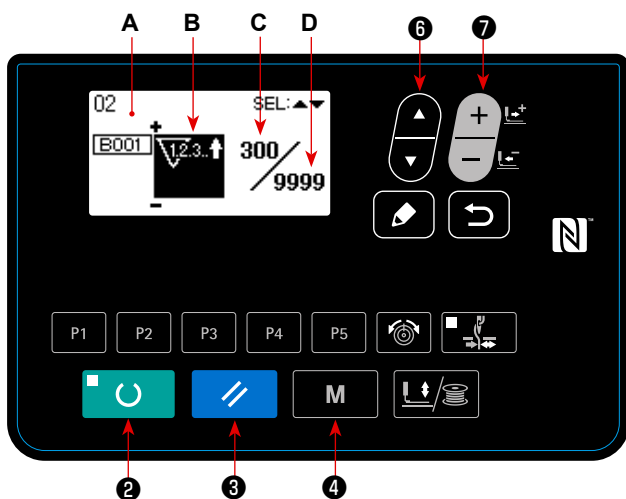

Counter screen **A** is displayed to accept setting.

The value for the counter can only be set under the input mode. In the case of the sewing mode, press READY key  ② to enter the input mode.

2) Selection of kinds of counters.

Press ITEM SELECT key  ⑥ to display the pictograph **B** which indicates the counter type in reverse video.

Press DATA CHANGE key  ⑦, and select the counter you desire from among the kinds of counters below.

3) Change of counter set value.

Press ITEM SELECT key  ⑥ to display the set value **C** of the counter in reverse video.

Press DATA CHANGE key  ⑦ and input the set value until count-up is reached.

4) Change of existing counter value.

Press ITEM SELECT key  ⑥ to display the current value **D** of the counter in reverse video.

Press RESET key  ③ and the value on the way of counting can be cleared.

In addition, it is possible to edit the numerical value with DATA CHANGE key  ⑦.

(2) Kind of counter

① Sewing UP counter

 Every time the sewing of one shape is performed, the existing value is counted up. When the existing value is equal to the set value, count-up screen is displayed.

② Sewing DOWN counter

 Every time the sewing of one shape is performed, the existing value is counted down. When the existing value is reached to "0", count-up screen is displayed.

③ No. of pcs. UP counter

 The current value shown on the counter is added by one every time the cycle sewing is carried out. When the existing value is equal to the set value, count-up screen is displayed.

④ No. of pcs. DOWN counter

 The current value shown on the counter is subtracted by one every time the cycle sewing is carried out. When the existing value is reached to "0", count-up screen is displayed.

⑤ Bobbin thread count-up counter

 The current value on the counter is increased by one every time 10 stitches are sewn. When the current value equals to the set value, the count-complete screen is displayed.

⑥ Bobbin thread count-down counter

 The current value on the counter is decreased by one every time 10 stitches are sewn. When the current value is decreased to zero (0), the count-complete screen is displayed.

 ⑦ Counter not used

(3) Count-up releasing procedure

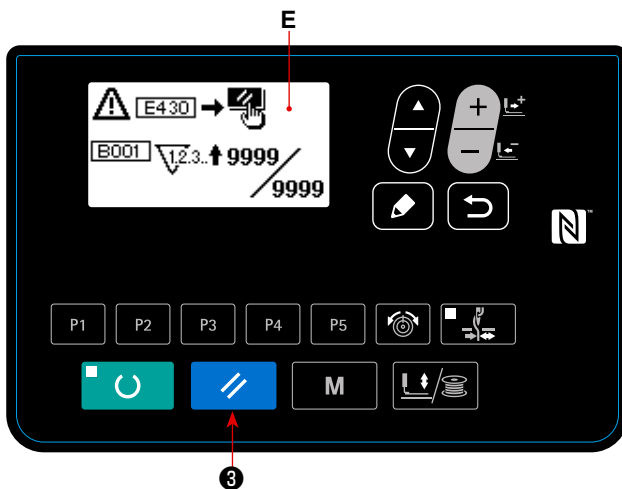

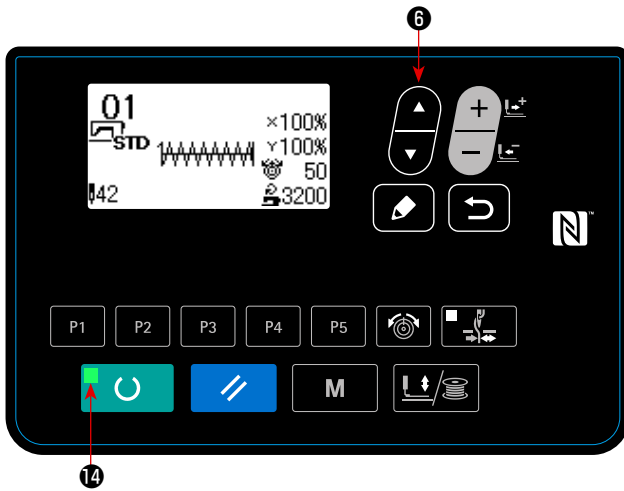

When count-up condition is reached during sewing work, the whole count-up screen **E** flashes on and off. Press RESET key  **3** to reset the counter, and the mode returns to the sewing mode. Then the counter starts counting again.

(4) How to check the counter in the ready state

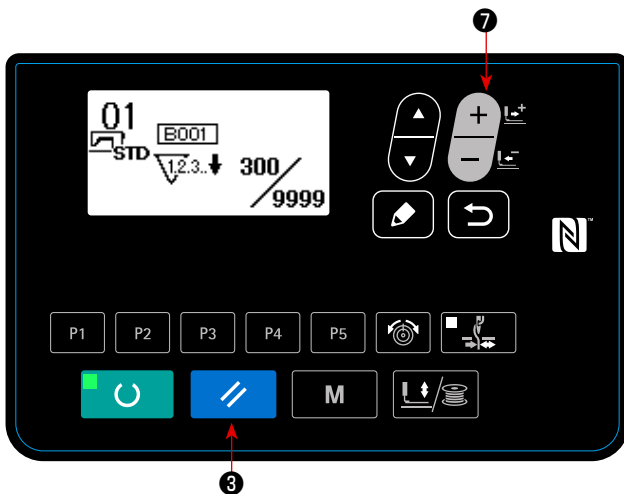

- 1) Under the sewing mode where SET READY LED **14** lights up, press ITEM SELECT key  **6** to display the counter screen.





- 2) On the counter screen, the current value on the counter can be updated with DATA CHANGE key  **7**. The current value on the counter can be cleared with RESET key  **3**.

* In the case the panel reset key is so set, with the memory switch U031, as to function as the pause switch, the pause function is disabled on this screen.



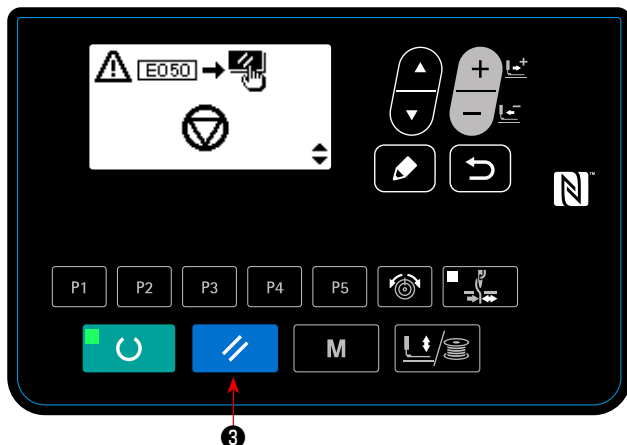

6-4. How to use the temporary stop

Once the RESET key function is set to the "pause" by means of the memory switch U031, the RESET key will function as the pause key to allow the sewing machine to be stopped during sewing. (Refer to "[I.8-2. List of the memory switch functions](#)" p.57.)

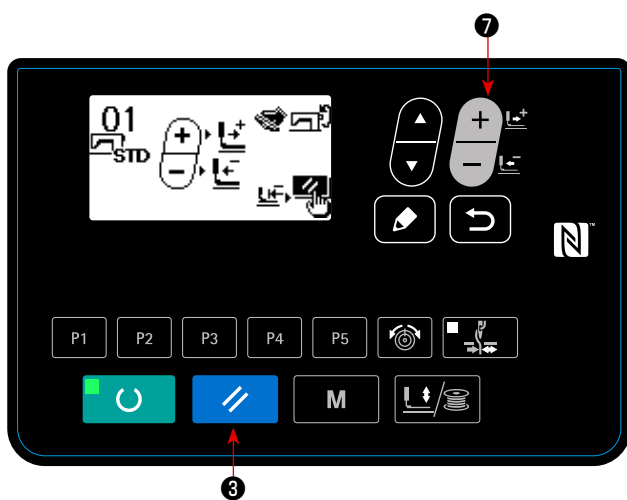

- 1) The sewing machine is stopped by pressing RESET key  **3** . At this time E050 is displayed. The error is reset by pressing RESET key  **3** . Then, the feed forward/backward screen is displayed.



- 2) Three operations can be carried out after the error is reset.
 1. Re-starting of sewing with the start switch
 2. Thread trimming by pressing RESET key  **3** , position adjustment with DATA CHANGE key  **7** , then re-starting of sewing with the start switch.
 3. Thread trimming by pressing RESET key  **3** . Then, origin retrieval by re-pressing RESET key  **3** .

6-5. Setting the pattern thread tension

Needle thread tension for 6 stitches at the sewing start, the portion which is changed over from basting stitch to zigzag stitch, and the portion of tie stitch at the sewing end can be individually set.

For the user pattern, the needle thread tension can be individually set as desired.

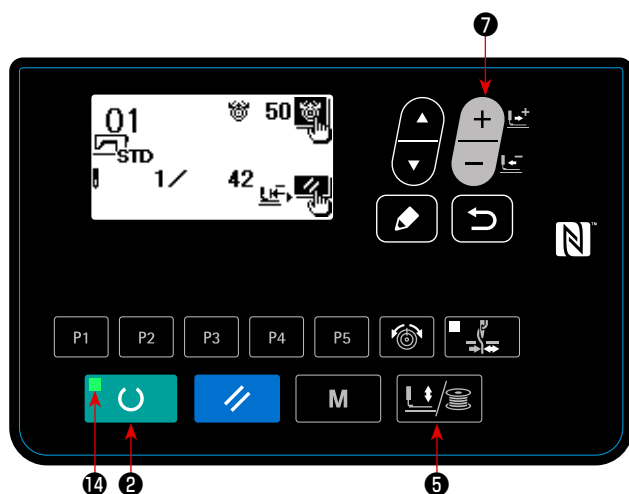



1) Press READY key  ② to light up SET READY LED ⑭ .

2) Turn ON work PRESSER and WINDER key  ⑤ to display the shape check screen.

3) Move the work clamp with DATA CHANGE key  ⑦ . When the point at which the thread

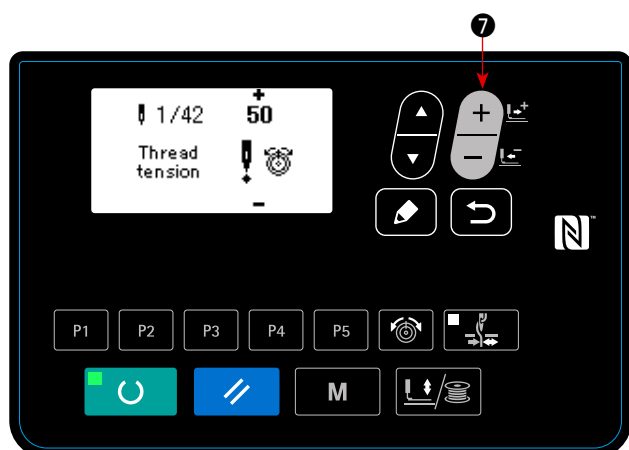
tension can be set is reached, the thread tension pictograph is displayed.





4) Press the THREAD TENSION key  ⑪ . Input the individual thread tension with DATA

CHANGE key  ⑦ . Then, press the RETURN key  ⑨ .

5) Repeat the steps 3) and 4) to set thread tension.

6) After the completion of setting of the thread tension, press RETURN key  ⑨ or RESET key

 ③ . When you press RESET key  ③ , the work clamp travels to the origin and goes up.

6-6. Copying or deleting various kinds of pattern data

Data of pattern No. which has been already registered can be copied to pattern No. which has not been used. Overwriting copy of the pattern is prohibited. When you desire to overwrite, perform it after erasing the pattern once.

The patterns that can be copied are the following three types.

- * To copy a standard pattern and user pattern to another user pattern.
- * To copy the pattern key
- * To copy the cycle pattern

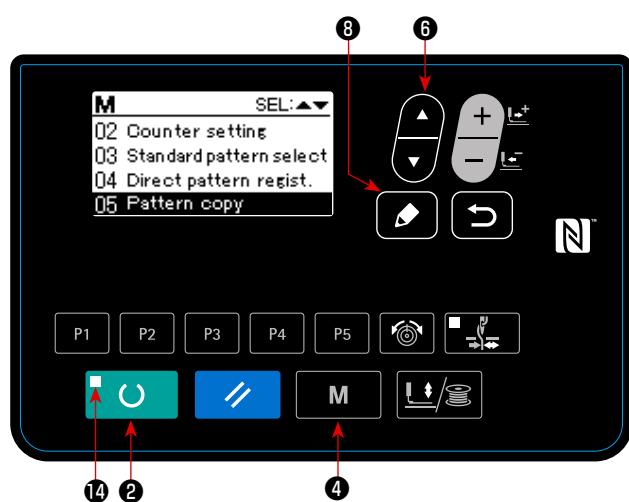

1) Set the mode to input mode.

Under the input mode where SET READY LED

14 goes out, copy is enabled.

If the current mode is the sewing mode, press READY key  2 to change over the mode to the input mode.

2) Displaying the mode screen

Press MODE key  4 to display the mode screen. Put the pattern copy in the selected state with ITEM SELECT key  6. Then, press

EDIT key  8.

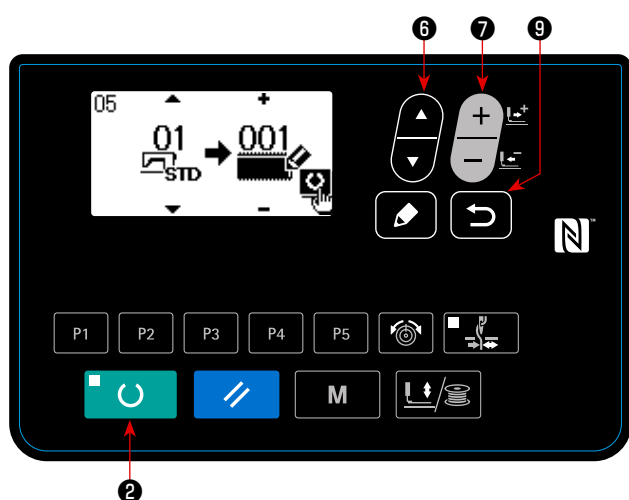

3) Call copy screen.

Press ITEM SELECT key  6 to select the source pattern number for copying.

The type of pattern that can be selected is the standard pattern and user pattern. Only the pattern numbers which have been registered are displayed.

When you press RETURN key  9, the copy function is cancelled and the screen returns to the mode screen.





4) Select pattern No. of copy destination.

Press DATA CHANGE key  7 to select the pattern number to be copied.

5) Start copying.

When READY key  2 is pressed, the copy starts. Then, the screen returns to the input screen on which the pattern No. which is created by copying is selected.

6) Erasing the pattern



In the case of erasing the pattern, select ITEM SELECT key  ⑥ to select the pattern number you want to delete. Press DATA CHANGE key  ⑦ to select Trash . Then, press READY key  ②. The delete confirmation screen is displayed. The pattern is deleted by pressing RESET key  ③ on this screen.

* The standard pattern cannot be deleted.

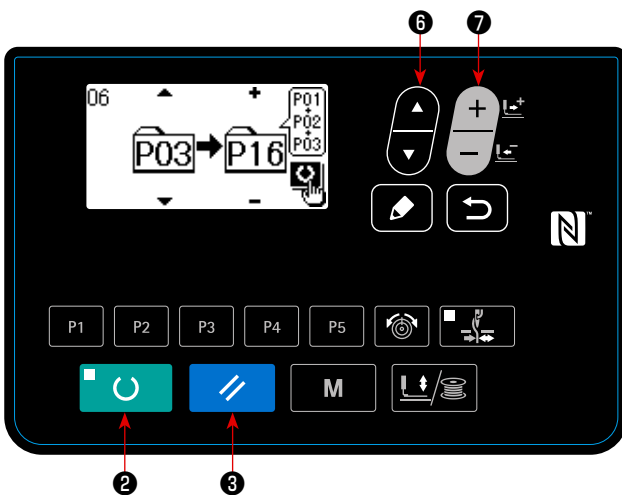

* In the case of copying the direct pattern, select "06 Direct pattern copy" on the mode screen. In the case of copying the cycle pattern, select "07 Cycle pattern copy" on the mode screen. Both the direct pattern and the cycle pattern can be copied in the similar procedure.

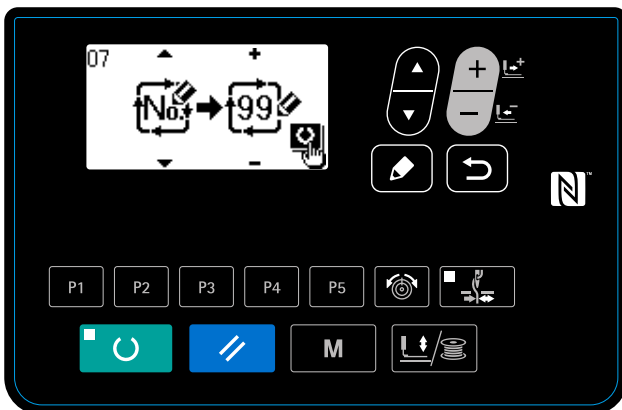

* The pattern key and the cycle pattern can be copied in the similar procedure. To create a new

cycle pattern, press ITEM SELECT key  ⑥ to select new creation .



* To select a copied user pattern, press ITEM SELECT key  ⑥ to display  when the pattern number is displayed on the upper left section of the screen. Then, press DATA CHANGE key  ⑦ to select a pattern number.

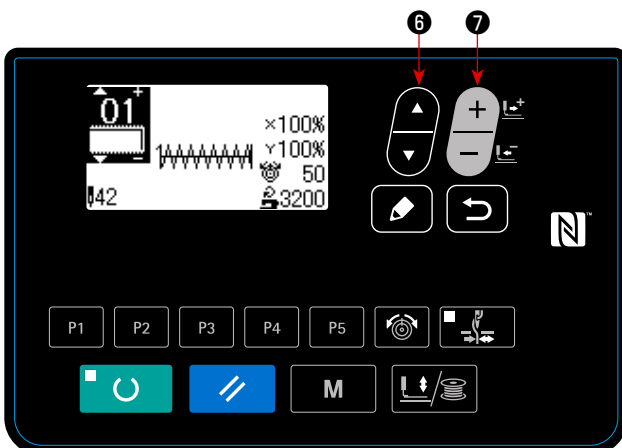

6-7. Communication

(1) USB thumb drive

① Precautions to be taken when handling USB devices

- Do not leave the USB device or USB cable connected to the USB port while the sewing machine is in operation. The machine vibration can damage the port section resulting in loss of data stored on the USB device or breakage of the USB device or sewing machine.
- Do not insert/remove a USB device during reading/writing a program or sewing data. It may cause data breakage or malfunction.
- When the storage space of a USB device is partitioned, only one partition is accessible.
- Some type of the USB device may not be properly recognized by this sewing machine.
- JUKI does not compensate for loss of data stored on the USB device caused by using it with this sewing machine.
- When the panel displays the communication screen or pattern data list, the USB drive is not recognized even if you insert a medium into the slot.
- For USB devices and media such as CF(TM) cards, only one device/medium should be basically connected/inserted to/into the sewing machine. When two or more devices/media are connected/inserted, the machine will only recognize one of them. Refer to the USB specifications.
- Insert the USB connector into the USB terminal on the IP panel until it will go no further.
- Do not turn the power OFF while the data on the USB flash drive is being accessed.

② USB specifications

- Conform to USB 1.1 standard
- Applicable devices *1 ___ Storage devices such as USB memory, USB hub, FDD and card reader
- Not-applicable devices ___ CD drive, DVD drive, MO drive, tape drive, etc.
- Format supported ___ FD (floppy disk) FAT 12
___ Others (USB memory, etc.), FAT 12, FAT 16, FAT 32
- Applicable medium size ___ FD (floppy disk) 1.44MB, 720kB
___ Others (USB memory, etc.), 4.1MB ~ (2TB)
- Recognition of drives ___ For external devices such as a USB device, the device which is recognized first is accessed. However, when a medium is connected to the built-in media slot, the access to that medium will be given the highest priority. (Example: If a medium is inserted into the media slot even when the USB memory has already been connected to the USB port, the medium will be accessed.)
- Restriction on connection ___ Max. 10 devices (When the number of storage devices connected to the sewing machine has exceeded the maximum number, the 11th storage device and beyond will not be recognized unless they are once disconnected and re-connected.)
- Consumption current ___ The rated consumption current of the applicable USB devices is 500 mA at the maximum.



*1: JUKI does not guarantee operation of all applicable devices. Some device may not operate due to a compatibility problem.

(2) How to use the communication function

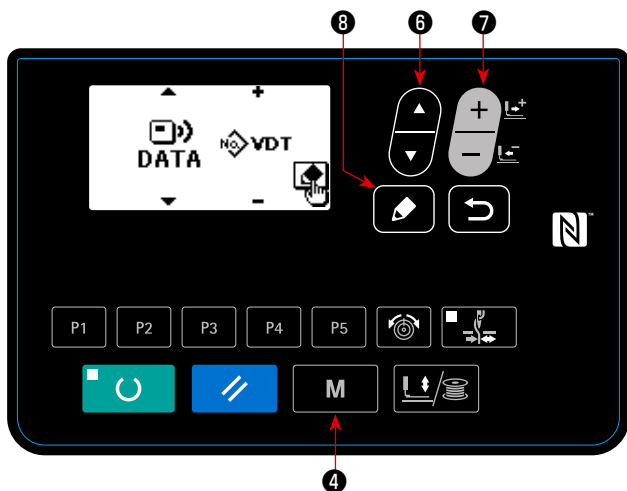
This sewing machine is capable of inputting/outputting data by means of an USB thumb drive.



1) Entering the communication mode.

Press MODE key **M** ④ to display the mode screen. Put the pattern copy in the selected state with ITEM SELECT key  ⑥. Then, press EDIT key  ⑧.

2) Selecting the type of communication.

Press DATA CHANGE key  ⑦ to select the type of communication.

Name of data		Extension	Description of data
Vector form data		VD00 XXX .VDT (XXX:001 to 999)	Data on needle entry points created with the PM-1. The data form is commonly used among JUKI sewing machine. (User pattern)

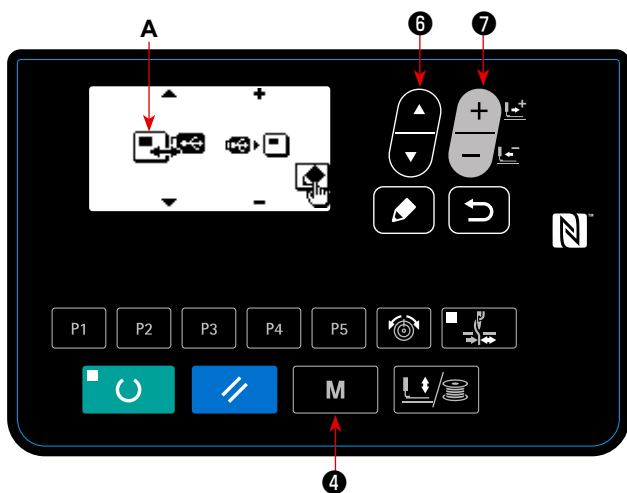

3) Selecting the communication direction

Press ITEM SELECT key  ⑥ to display pictograph **A** which shows the communication direction selection.

Press DATA CHANGE key  ⑦ to select the communication direction.

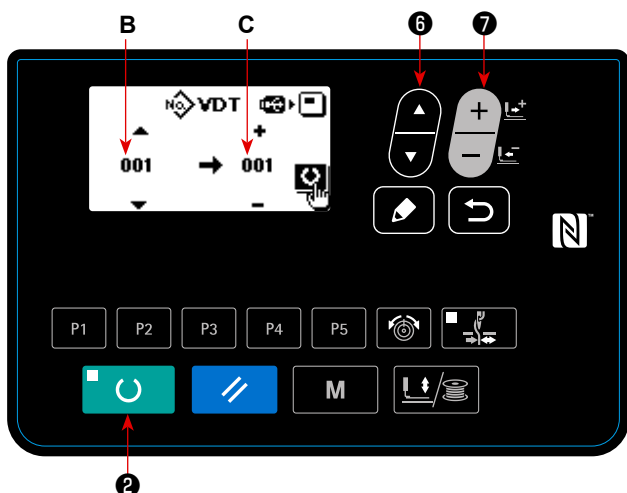

 : Data shown on the operation panel is written on the USB thumb drive.

 : Data stored on the USB thumb drive is read into the operation panel.



4) Selecting the number.

Press ITEM SELECT key  ⑥ to select file No. **B** to be read.

Press DATA CHANGE key  ⑦ to select file No. **C** to be written. Press set READY key  ② to write the data in file No. **C**.

(3) NFC

The operation panel supports NFC (Near Field Communication).

Sewing data, maintenance information or the like can be viewed, edited, copied, etc., on an Android terminal (such as tablet and smartphone) on which JUKI application for Android "JUKI Smart App" has been installed, by means of the NFC communication function.

Refer to the Instruction Manual for JUKI Smart App for details of JUKI application for Android "JUKI Smart App".

① Position of the NFC antenna

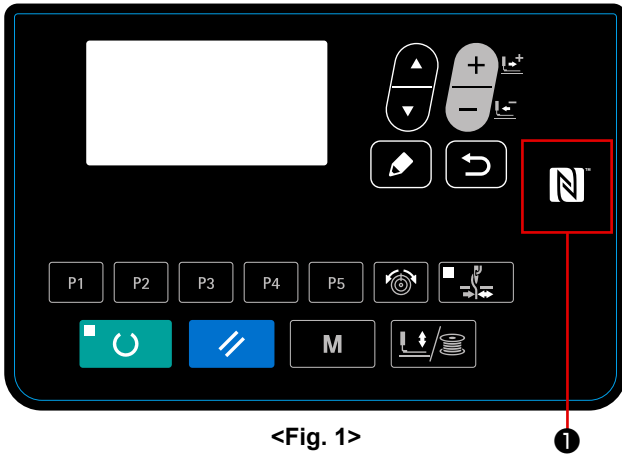

<Fig. 1>

[Position of the NFC antenna]

In the case of carrying out the NFC communication between the sewing machine and a tablet or smartphone, bring the antenna of the tablet or smartphone near to NFC mark ❶ as shown in Fig. 2.

* If the NFC communication has failed, error message will be displayed on the tablet/smartphone screen.

When the error message is displayed on the screen, carry out the NFC communication again.

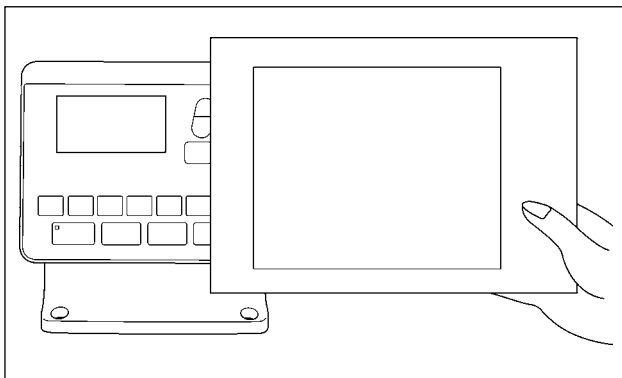

<Fig. 2>

② Precautions to be taken when handling NFC

- The position of the NFC antenna varies according to the tablet/smartphone used. Be sure to read the instruction manual of your device before using the NFC communication function.
- To use the NFC communication function, place the NFC communication function setting in "Enable" while referring to the instruction manual for your tablet/smartphone.

6-8. Cautions in operation

- (1) When the error indicator lamp lights up, be sure to check the cause of trouble and take a proper corrective measure.
- (2) Do not draw, by hand, the material being sewn during sewing. Doing so will cause the needle shift from the correct position. If the needle moves from the correct position, press READY key  two times. This will return the needle to the normal origin.
- (3) Do not turn OFF the power in a state that the needle is lowered. The presser comes down and the wiper interferes with needle. As a result, there is a danger of needle breakage or the like.

Reference for the sewing speed to be applied

Sewn product / thread / needle	Head type / Sewing speed
8-layered denim / Cotton thread #50 / DPx5 #16	S (Standard) / 3,200 sti/min
8-layered woolen gabardine / Polyester filament #50 / DPx5 #14	S (Standard) / 2,300 sti/min
8-layered denim / Cotton thread #20 / DPx17 #19	H (Heavy-weight material)/3,200 sti/min, W (Double-capacity hook)/2,700 sti/min
Overlapped sewing of 6 x 12-layered denim / Cotton thread #20 / DPx17 #19	H (Heavy-weight material) / 2,500 sti/min
Tricot + shoulder strap (3 + 1) layered section / Polyester spun #60 / DPx5 #11	F (Foundation) / 2,000 sti/min

- * To prevent the thread breakage due to the needle heat, set the sewing speed referring to the above table in accordance with the sewing conditions.
- * For sewing the foundation or the like, lower the height of the needle bar to prevent the stitch skipping. (Refer to the item "[I.7-1. Adjusting the height of the needle bar](#)" p.49).

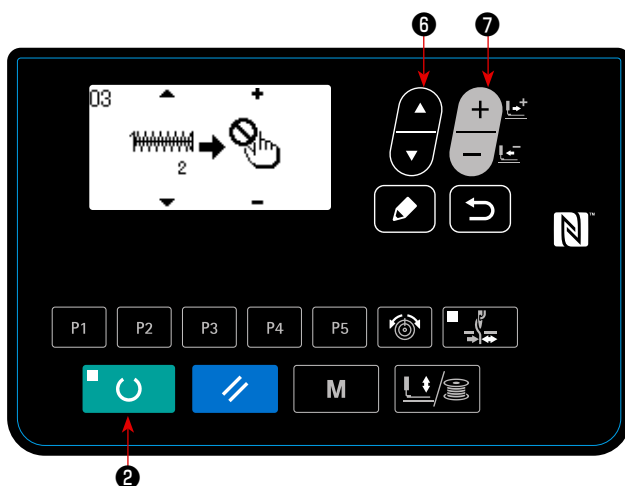
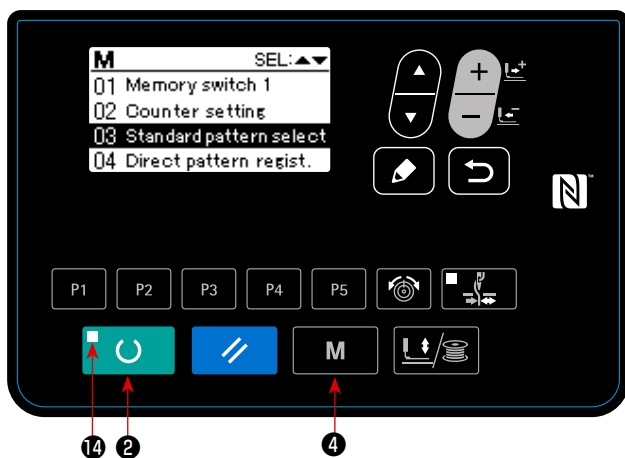

6-9. Setting enable/disable of standard pattern invoking

Invoking of a wrong pattern is prevented by disabling invoking of unnecessary patterns.
In addition, necessary patterns can be invoked and used.





Example of setting: Invoking of pattern No. 2 is disabled.

1) Putting the sewing machine in the input mode
Under the input mode where the SET READY LED 14 goes out, setting of data is enabled.
Under the sewing mode, press READY key  2 to change over the mode to the input mode.

2) Press MODE key  4 to display the mode screen. Set the standard pattern use/disuse selection in the "use" state with ITEM SELECT key  6. Then, press the select key.

3) Press ITEM SELECT key  6 to display pattern No. 2.

4) Press DATA CHANGE key  7 to select use/disuse of the pattern.

 : Use

 : Disuse

6-10. Setting the irregular work



In the case the sewing machine is not operated for a certain period of time, the work descriptions for that period can be input through the operation panel.

The data on the input work description can be collected and displayed by means of "JUKI Smart App".

Setting of irregular work should be carried by means of "JUKI Smart App". The set details can be checked on the operation panel.

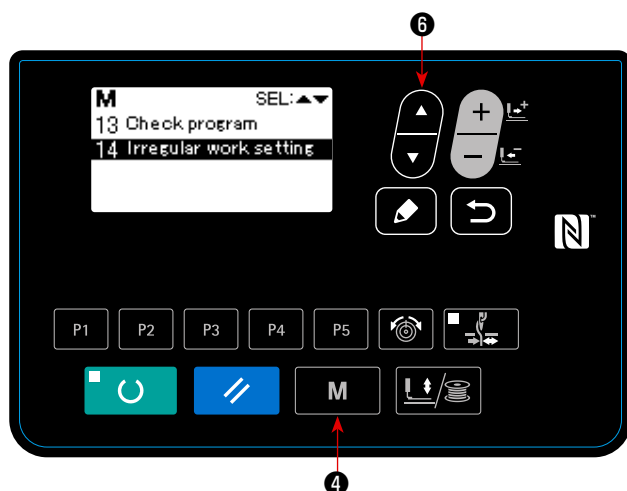
① Selecting the irregular work setting function



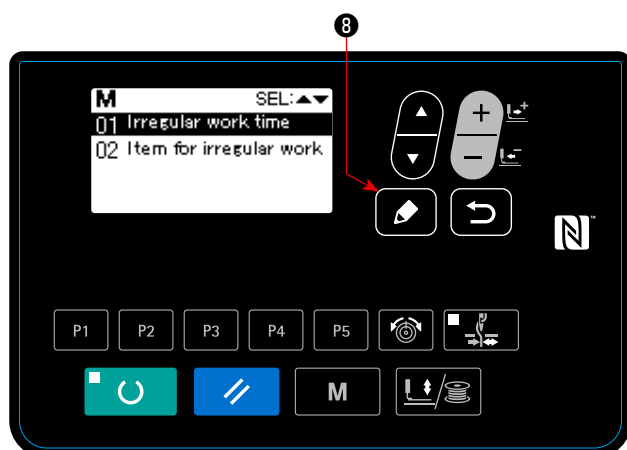

1. Keep MODE key **4**  held pressed for three seconds. Then, select "14. Setting the irregular work" with ITEM SELECT key **6** . The "irregular work setting screen" is displayed.

② Inputting the irregular work



Enter the time during which the irregular work input screen is displayed in the case the sewing machine is not operated.

1. In the state where the "irregular work setting screen" is selected, press EDIT key **8** . Select the "irregular work time" and press EDIT key **8** . The "irregular work hours input screen" is displayed.

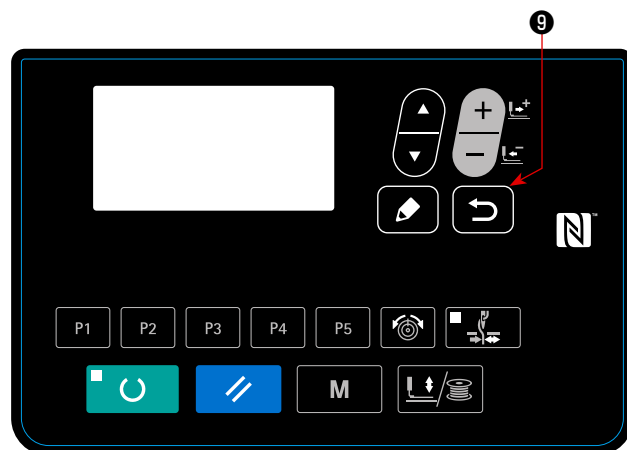



2. The preset time (in seconds) during which the irregular work input screen is displayed is displayed.
Range : 0 to 1800 (Seconds)
Initial value : 0 (Function is turned)
Press RETURN key **9**  to display the "irregular work setting screen".

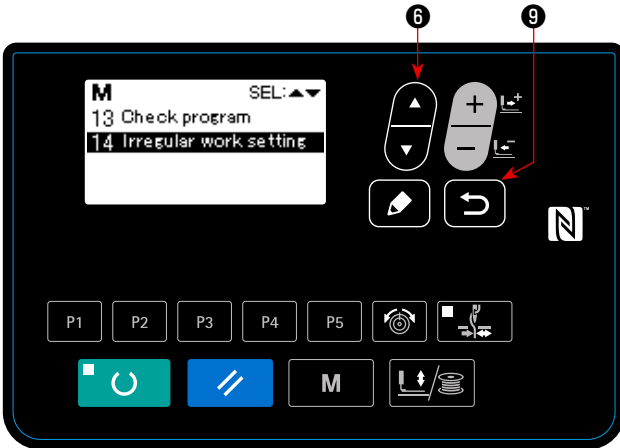

③ Displaying the "irregular work setting function"

Work items that are displayed on the irregular work input screen are displayed.
Carry out setting of work items by means of "JUKI Smart App".

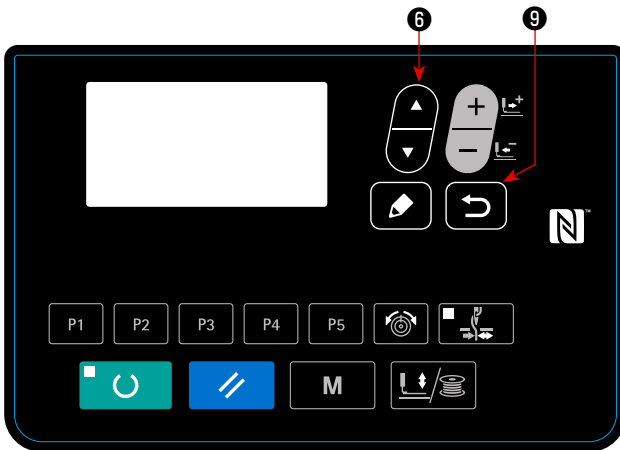

1. Press ITEM SELECT key  6 on the "Irregular work items setting screen".
Select the "setting irregular work items" and press RETURN key  9 to confirm the selection.
The "irregular work items setting screen" is displayed.



2. Work items can be checked by pressing ITEM SELECT key  6 .
Press RETURN key  9 to display the "irregular work setting screen".

* The work items are as listed below.

No.	Work items	No.	Work items
01	Condition maintenance	08	Work meeting
02	Product arrangement	09	Transport
03	Thread change	10	Transfer
04	Record	11	Waiting for work
05	Failure	12	Fatigue
06	Judgment	13	Errand
07	Correction	14	Omission of duty

7. MAINTENANCE

7-1. Adjusting the height of the needle bar



WARNING :

Turn OFF the power before starting the work so as to prevent accidents caused by abrupt start of the sewing machine.

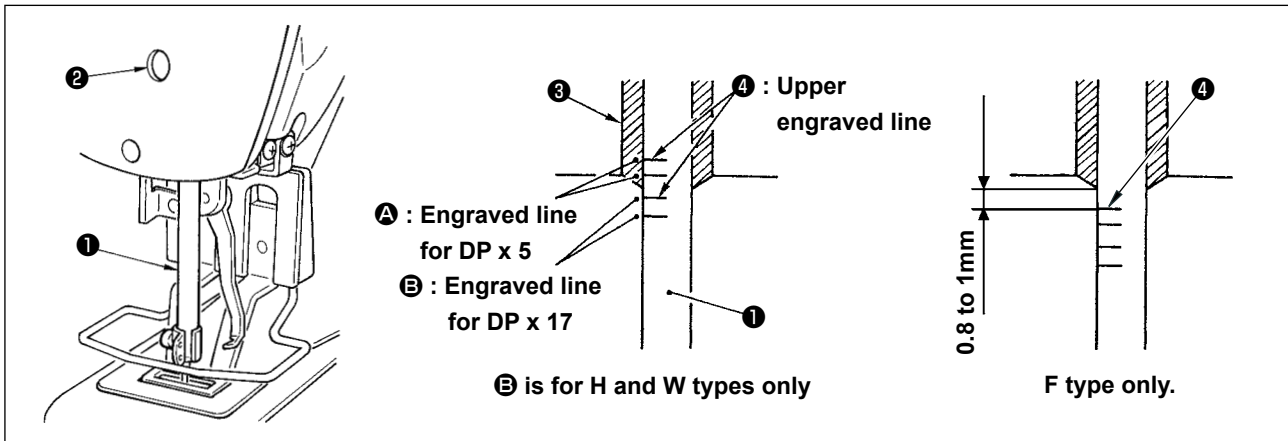

Bring needle bar **1** to the lowest position of its stroke. Loosen needle bar connection screw **2** and adjust so that upper marker line **4** engraved on the needle bar aligns with the bottom end of needle bar bushing, lower **3**. For F type only, adjust the needle bar to the position where it is lowered by 0.8 to 1 mm from the center of upper marker line **4** engraved on the needle bar.



After the adjustment, make sure that there is no uneven torque.

* When stitch skipping occurs in accordance with the sewing conditions, adjust the height of the needle bar so as to lower it by 0.5 to 1 mm from the needle bar engraved line **4**.

7-2. Adjusting the needle-to-shuttle relation



WARNING :

Turn OFF the power before starting the work so as to prevent accidents caused by abrupt start of the sewing machine.

Relation between needle and engraved lines

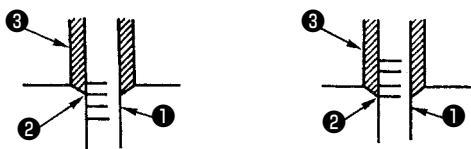

- 1) Turn the handwheel by hand. When needle bar ① has gone up, adjust so that lower marker line ② engraved on the needle bar aligns with the bottom end of the needle bar bushing ③, lower.

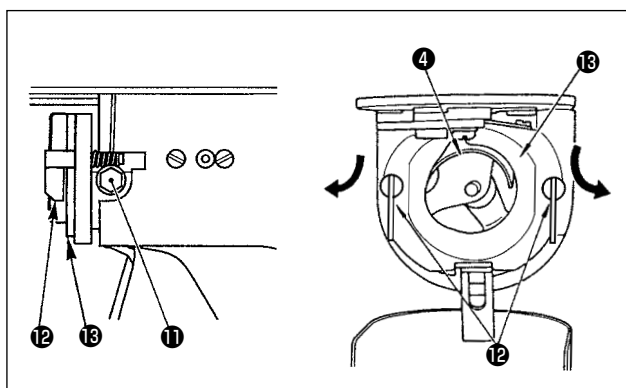

- 2) Loosen setscrew ⑪ in the driver. Open inner hook pressers ⑫ to the right and left, and remove inner hook presser ⑬.

Caution At this time, be careful not to let inner hook ④ come off and fall.

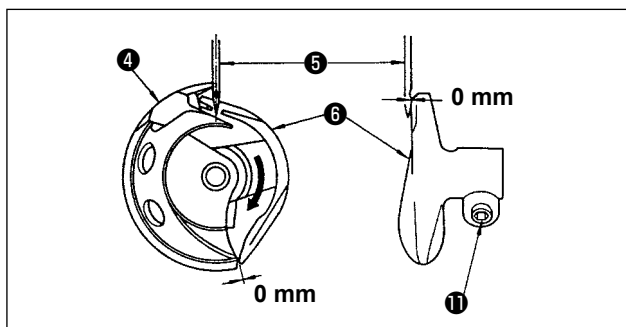

- 3) Adjust so that the blade point of inner hook ④ aligns with the center of needle ⑤, and that a clearance of 0 mm is provided between the front end of the driver and the needle as the front end face of driver ⑥ receives the needle to prevent the needle from being bent. Then tighten setscrew ⑪ of the driver.

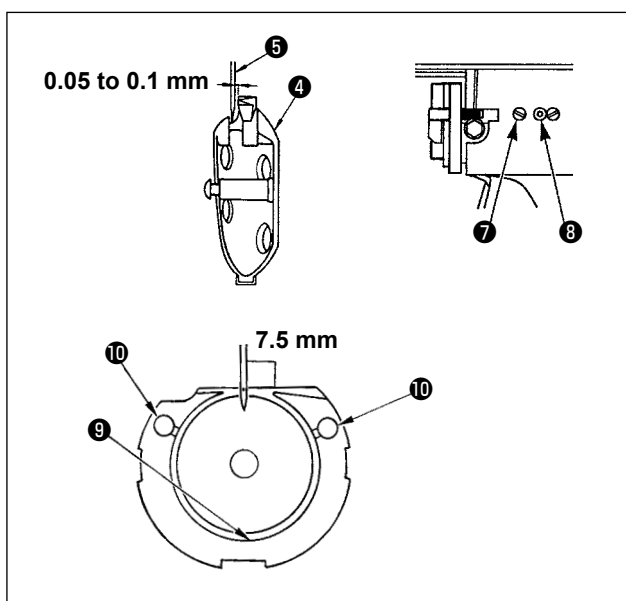

- 4) Loosen setscrew ⑦ of the shuttle, and adjust the longitudinal position of the shuttle. To do this adjustment, turn shuttle race adjusting shaft ⑧ clockwise or counterclockwise to provide a 0.05 to 0.1 mm clearance between needle ⑤ and the blade point of inner hook ④.
- 5) After adjusting the longitudinal position of the shuttle, further adjust to provide a 7.5 mm clearance between the needle and the shuttle by adjusting the rotating direction. Then tighten setscrew ⑦ of the shuttle.

Caution If the sewing machine is left unused for a long time, or after clearing the area surrounding the hook section, apply a little quantity of oil to race section ⑨ and felt ⑩ before using the sewing machine.

7-3. Adjusting the lift of the work clamp foot



WARNING :

As the work is performed while the power is ON, never touch the switches other than the necessary one so as to prevent accidents caused by the malfunction of switches.

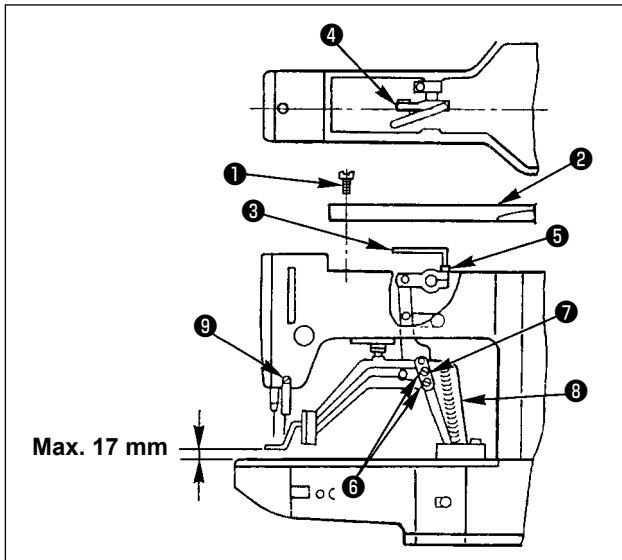

- 1) With the machine in stop mode, remove six set-screws ① of the top cover, and take off top cover ② .
- 2) Apply L-shaped wrench ③ to socket bolt ⑤ of clamp ④ , and loosen the socket bolt.
- 3) Push down L-shaped wrench ③ to increase the lift of the work clamp foot, or pull it up to decrease the lift.
- 4) After the adjustment, securely tighten socket bolt ⑤ .
- 5) If the right and left work clamp feet are not levelled, loosen fixing screw ⑥ and adjust the position of the work clamp foot lever support plate ⑦ to level them.



At this time, be careful not to cause work clamp foot lever support plate ⑦ to interfere with feed bracket ⑧ .

If the work clamp foot lever support plate interferes with the wiper, readjust the height of the wiper using setscrew ⑨ in the wiper installing base.

7-4. The moving knife and counter knife



WARNING :

Turn OFF the power before starting the work so as to prevent accidents caused by abrupt start of the sewing machine.

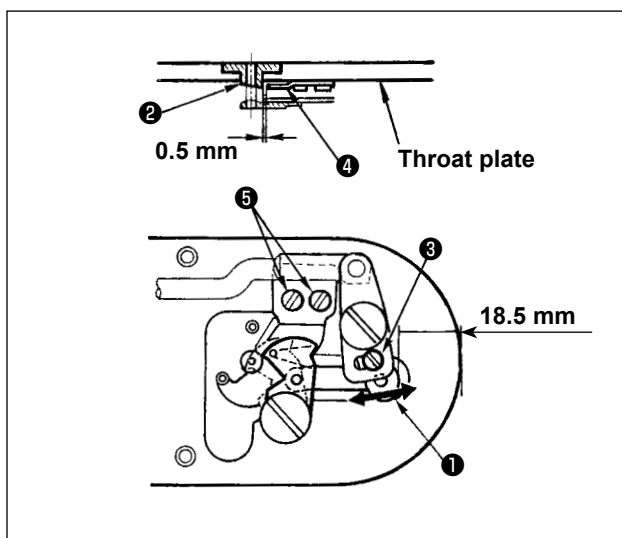

- 1) Loosen adjusting screw ③ so that a clearance of 18.5 mm is provided between the front end of the throat plate and the top end of thread trimmer lever, small ① . To adjust, move the moving knife in the direction of arrow.
- 2) Loosen setscrew ⑤ so that a clearance of 0.5 mm is provided between needle hole guide ② and counter knife ④ . To adjust, move the counter knife.

7-5. Needle thread clamp device



WARNING :

Turn OFF the power before starting the work so as to prevent accidents caused by abrupt start of the sewing machine.

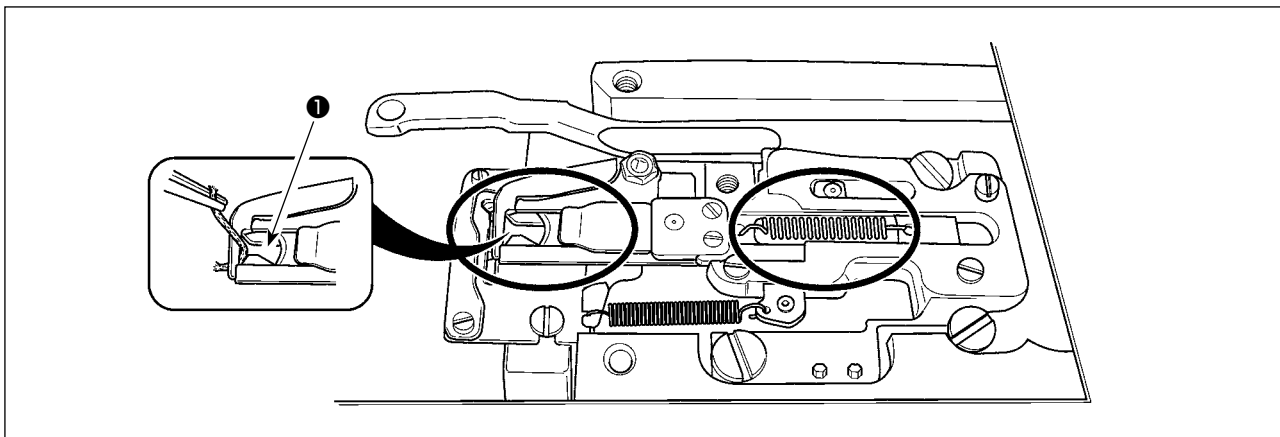

When thread is caught at top end ❶ of the thread clamp, thread clamp becomes incomplete and sewing trouble at the sewing start will be caused. Lint and thread dust are likely to gather in the circled section. It is necessary to remove the throat plate to periodically clean the section.

7-6. Adjustment of the wiper



WARNING :

Turn OFF the power before starting the work so as to prevent accidents caused by abrupt start of the sewing machine.

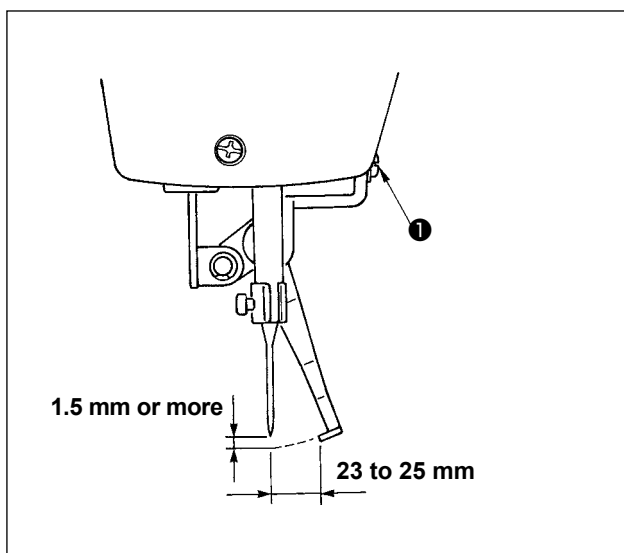

- 1) Loosen screw ❶ to adjust so that a clearance of 1.5 mm or more is provided between the wiper and the needle.

At this time, the standard of the distance between the wiper and the needle is 23 to 25 mm. By adjusting the distance wide, the work clamp foot can prevent stepping on needle thread when it comes down.

Especially when the thin needle is used, adjust the distance wide to such an extent of 23 mm.

- * The position of the needle is when the sewing machine has stopped after the sewing finished.

7-7. Draining waste oil

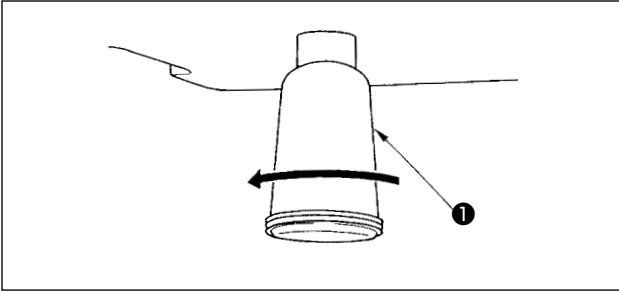

When polyethylene oiler ① becomes filled with oil, remove polyethylene oiler ① and drain the oil.

7-8. Amount of oil supplied to the hook

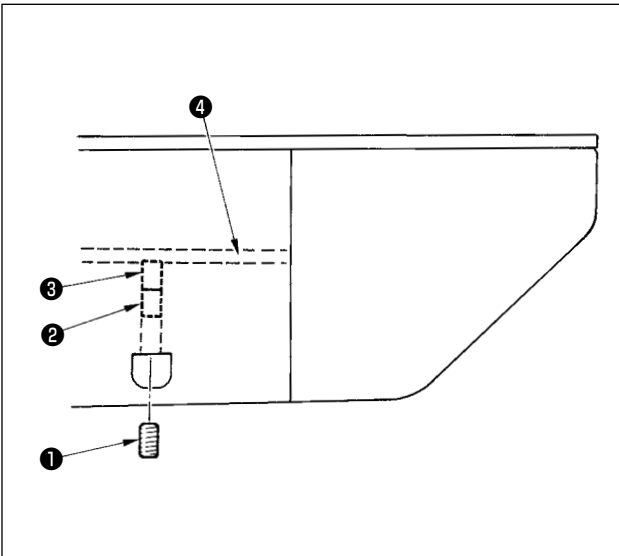

- 1) Loosen setscrew ① and remove setscrew ① .
- 2) When screwing in adjustment screw ② , the amount of oil of oil pipe, left ④ can be reduced.
- 3) After the adjustment, screw in setscrew ① and fix it.

1. The state of standard delivery is the position where ③ is lightly screwed in and returned by 4 turns.

2. When reducing the amount of oil, do not screw in the screw at once. Observe the state for approximately half a day at the position where ③ is screwed in and returned by 2 turns. If reducing is excessive, worn-out of the hook will result.



7-9. Replacing the fuse

DANGER :



1. To avoid electrical shock hazards, turn OFF the power and open the control box cover after about five minutes have passed.
2. Open the control box cover after turning OFF the power without fail. Then, replace with a new fuse with the specified capacity.

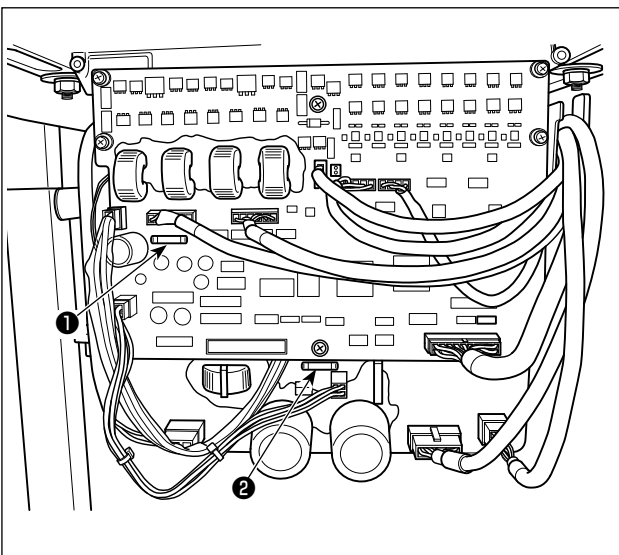

The machine uses the following two fuses :

MAIN PWB

- ① For pulse motor power supply protection
5A (time-lag fuse)

SDC PWB

- ② For control power supply protection
2A (fast-blow type fuse)

7-10. Replenishing the designated places with grease

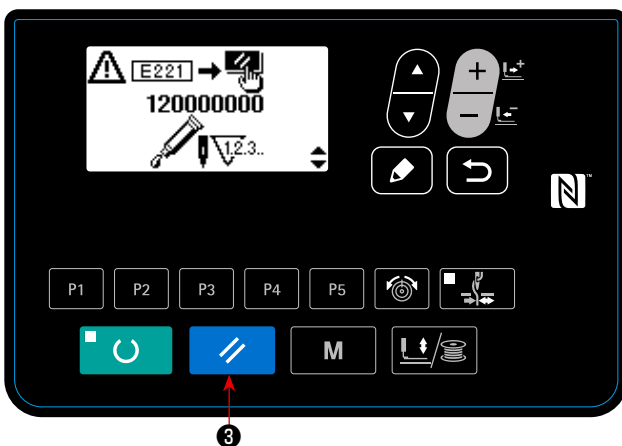
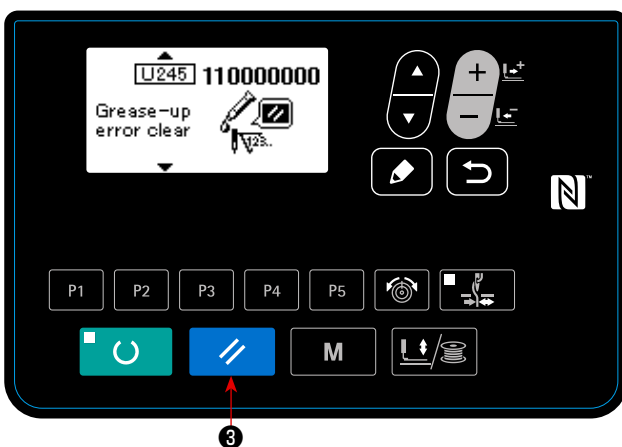
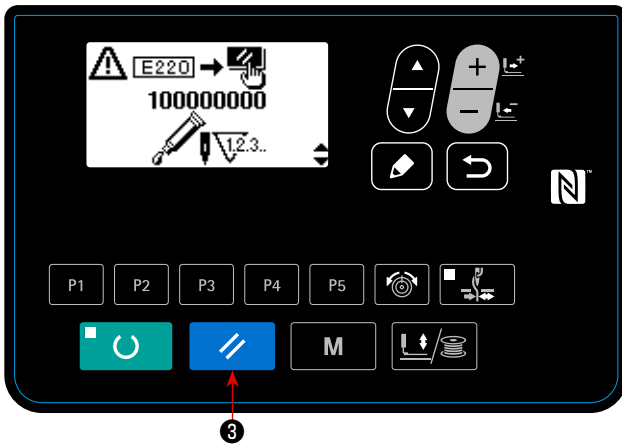

When the sewing machine has been used for a certain number of times of sewing, error code No. E220 is displayed on the operation panel at the time of turning ON the power. This display informs the operator of the time of replenishing the designated places with grease. Be sure to replenish the places with the grease below. Then call the memory switch No. 245 and set it to "0" with the RESET key  ③.

Even after the display of the error No. E220, when the RESET key  ③ is pressed, the error is released, and the sewing machine can be continuously used. Afterwards, however, the error No. E220 is displayed every time the power is turned ON.

In addition, when the sewing machine is used further for a certain period of time after the display of error No. E220, the error No. E221 is displayed and the sewing machine fails to operate since the error cannot be released even when the RESET key  ③ is pressed.

When the error No. E221 is displayed, be sure to replenish the designated places below with grease. Then start up the memory switch and set No. 245 to "0" with the RESET key  ③.



1. After replenishing the places with grease, the error No. E220 or No. E221 is displayed again unless the memory switch No. 245 is changed to "0".
2. Use grease tube (Part No. 40006323) supplied as accessories to replenish the designated places below with grease. If grease other than the designated one is replenished, damage of components will be caused.

**WARNING :**

Turn OFF the power before starting the work so as to prevent accidents caused by abrupt start of the sewing machine.

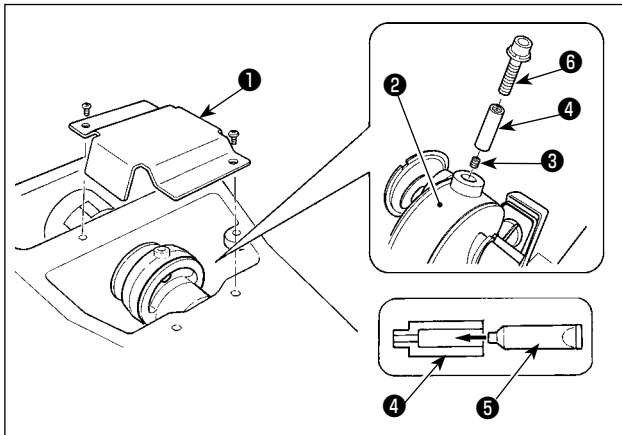
(1) Replenishing the eccentric cam section with grease

- 1) Open crank rod cover ① .
- 2) Remove setscrew ③ from the grease inlet cover located at periphery of crank rod ② .
- 3) Fill coupling ④ with grease through JUKI Grease A tube ⑤ .
- 4) Sink screw ⑥ supplied with the unit into the coupling to add the grease.
- 5) After adding the grease, securely tighten setscrew ③ which has been removed.

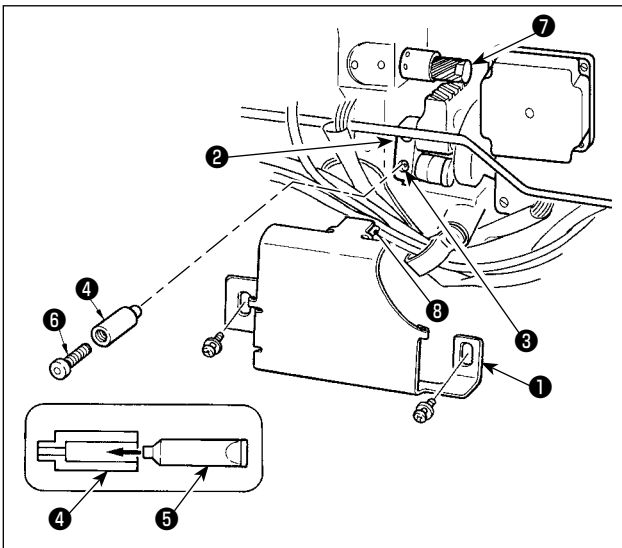
(2) Replenishing the oscillator pin section with grease

- 1) Tilt the machine head and remove the grease cover ① .
- 2) Remove setscrew ③ in oscillator gear ② .
- 3) Fill coupling ④ with grease through JUKI Grease A tube ⑤ .
- 4) Sink screw ⑥ supplied with the unit into the coupling to add the grease.
- 5) Securely tighten setscrew ③ which has been removed after replenishing with the grease.
- 6) Install grease cover ① at the location where felt ⑧ comes in contact with gear ⑦ .



**Do not strongly press felt ⑧ against gear ⑦ .
It can cause a moving failure.**

8. HOW TO USE THE MEMORY SWITCH

8-1. Method of changing memory switch data

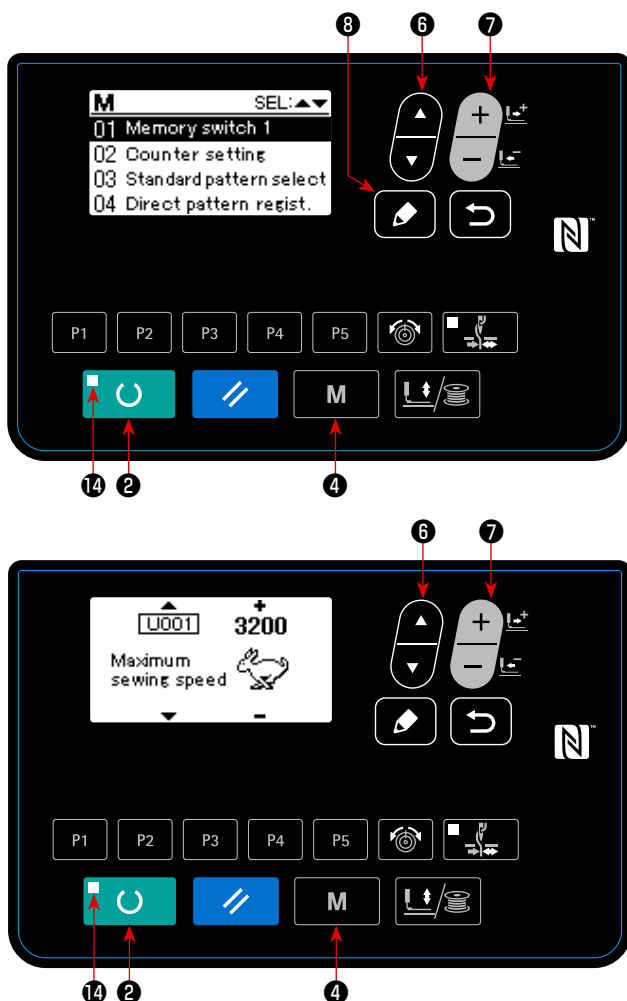



1) Set the mode to input mode.

Under the input mode where SET READY LED 14 goes out, change to the memory switch data is enabled.

If the current mode is the sewing mode, press READY key  2 to change over the mode to the input mode.

2) Call memory switch data edit screen.

When MODE key  4 is pressed, the mode screen (operator level) is displayed. On this screen, select the memory switch data (level 1).

Press ITEM SELECT key  6 to select "01 Memory switch 1". When you press EDIT key  8, the memory switch data screen appears.

3) Select memory switch data to change.

Press ITEM SELECT key  6 and select the data item which you desire to change.

4) Change data.

There are one data item to change the numerical value and the other data item to select the pictograph in the memory switch data.



























No. such as **U001** is attached to the data item to change the numerical value. Set value can be changed by increasing/decreasing the value with DATA CHANGE key  7.







































No. such as **U019** is attached to the data item to select the pictograph. Pictograph can be selected with DATA CHANGE key  7.







































→ For the details of memory switch data, refer to "[I.8-2. List of the memory switch functions](#)" p.57.









8-2. List of the memory switch functions

Various operations of the sewing machine can be set by programming the memory switch.
The initial setting values at the time of shipment differ with models.

No.	Function	Setting range	State when delivered	Remarks
U001	Max. sewing speed (Speed can be set in a unit of 100 sti/min.) 	400 to 3200	3200	For LK-1901BN and LK-1902B set to 3000. For LK-1903BN and LK-1900BNW set to 2700.
U002	Sewing speed of 1st stitch (With needle thread clamp) (Speed can be set in a unit of 100 sti/min.) 	400 to 1500	1500	
U003	Sewing speed of 2nd stitch (With needle thread clamp) (Speed can be set in a unit of 100 sti/min.) 	400 to 3200	3200	
U004	Sewing speed of 3rd stitch (With needle thread clamp) (Speed can be set in a unit of 100 sti/min.) 	400 to 3200	3200	
U005	Sewing speed of 4th stitch (With needle thread clamp) (Speed can be set in a unit of 100 sti/min.) 	400 to 3200	3200	
U006	Sewing speed of 5th stitch (With needle thread clamp) (Speed can be set in a unit of 100 sti/min.) 	400 to 3200	3200	
U007	Thread tension of 1st stitch (With needle thread clamp) 	0 to 200	200	
U008	Thread tension at the time of thread trimming 	0 to 200	0	
U009	Changeover timing of thread tension at the time of thread trimming 	-6 to 4	0	
U010	Sewing speed of 1st stitch (Without needle thread clamp) (Speed can be set in a unit of 100 sti/min.) 	400 to 1500	400	
U011	Sewing speed of 2nd stitch (Without needle thread clamp) (Speed can be set in a unit of 100 sti/min.) 	400 to 3200	900	
U012	Sewing speed of 3rd stitch (Without needle thread clamp) (Speed can be set in a unit of 100 sti/min.) 	400 to 3200	3200	
U013	Sewing speed of 4th stitch (Without needle thread clamp) (Speed can be set in a unit of 100 sti/min.) 	400 to 3200	3200	
U014	Sewing speed of 5th stitch (Without needle thread clamp) (Speed can be set in a unit of 100 sti/min.) 	400 to 3200	3200	
U015	Thread tension of 1st stitch (Without needle thread clamp) 	0 to 200	0	
U016	Changeover timing of thread tension at the sewing start (Without needle thread clamp) 	-5 to 2	-5	
U019	Selection of pedal  : Standard pedal  : Standard pedal (2-step stroke)  : Optional pedal  : Optional pedal (2-step stroke)	-		
U020	Selection of start pedal  : Standard pedal  : Optional pedal	-		
U024	Optional pedal 1 operation  : OFF when depressing pedal again  : OFF when detaching from pedal	-		

No.	Function	Setting range	State when delivered	Remarks
U025	Optional pedal 2 operation  OFF when depressing pedal again  OFF when detaching from pedal	-		
U026	Height of work clamp foot at the time of 2-step stroke 	50 to 90	70	Height is lowered when the set value is increased.
U030	Selection of base point of pattern enlargement/reduction  : Origin  : Sewing start point	-		
U031	Sewing machine operation can be stopped with panel key (clear key).  : Ineffective  : Panel RESET key  : External switch	-		
U032	Buzzer sound can be prohibited.  : Without buzzer sound  : Panel operation sound  : Panel operation sound + error sound	-		
U033	Number of stitches that needle thread clamp releases is set. 	1 to 20 stitches	2	
U034	Clamping timing of needle thread clamp can be delayed. 	- 10 to 4	4	Timing is delayed in "-" direction.
U035	Needle thread clamp control can be prohibited.  : Normal  : Prohibited	-		Misapplication of panel is protected. For LK-1903BN, set to "  ".
U036	Feed timing is selected. When stitches are not well-tightened, set the value in "-" direction. 	- 8 to 16	12	Setting on excessive "-" side may cause needle breakage. Be careful when sewing heavy-weight material.
U037	State of work clamp foot after completion of sewing can be selected.  : Work clamp foot goes up after moving at the sewing start  : Work clamp foot goes up immediately after the end of sewing.  : Work clamp foot goes up by pedal operation after moving at the sewing start.	-		For LK-1903BN/BR35, set to "  ".
U039	Execution of origin retrieval every time after completion of sewing can be performed. (Except cycle stitching)  : Without origin retrieval  : With origin retrieval	-		
U040	Setting of origin retrieval in cycle stitching can be set.  : Without origin retrieval  : Every time 1 pattern is completed  : Every time 1 cycle is completed	-		
U041	State of work clamp foot when machine stopped by temporary stop command can be selected.  : Work clamp foot goes up.  : Work clamp foot goes up with work clamp foot switch.  : Lift of work clamp foot is prohibited.	-		

No.	Function	Setting range	State when delivered	Remarks
U042	Needle bar stop position is set.  : UP position  : Upper dead point	-		Needle bar rotates in the reverse direction after the UP position stop and stops when upper dead point stop is set.
U046	Thread trimming can be prohibited.  : Normal  : Thread trimming prohibited	-		
U048	Route of origin return by means of clear key can be selected.  : Straight line return  : Reverse return of pattern	-		This function is used when straight line return from the midway of pattern to the start of sewing is not possible.
U049	Bobbin winding speed can be set.	800 to 2000	1600	Max. speed limitation has priority.
U050	Operation timing of material closing is selected. LK-1901BN only  : Output prohibited  : Operation when work clamp foot comes down.  : Operation at the time of start	-		For the machines other than LK-1901BN, this function is not indicated.
U051	Wiper operation method can be selected.  : Without wiper at the time of thread trimming on the way  : With wiper at the time of thread trimming on the way ①  : With wiper at the time of thread trimming on the way ②  : Magnet wiper	-		① : Without return of the last wiper ② : With return of the last wiper
U055	Effective/ineffective of tie stitching for button sewing can be selected.  : Tie stitching effective  : Tie stitching ineffective	-		-
U064	The dimension input increment can be selected.  % : In percentage (%)  mm : In dimension	-		
U065	Y origin shift method can be selected.  : Standard  : Offset by -5 mm (for 1904 work clamp)	-		
U069	Common/individual of the 2-step stroke height is selected.  : Common  : Individual (the height can be set with respect to each direct pattern)	-		
U070	Display/hide of the travel of the last stitch can be set.  : Hide  : Display	-		
U074	The fan operation can be set.  : Energy saving mode  : Constantly operates	-		
U075	With/without air pressure detection  : Without  : With * This memory switch is displayed only for the LK-1900BBN, LK-1903BBN.	-		

No.	Function	Setting range	State when delivered	Remarks
U076	Correction of thread waste retaining position With this switch, the timing to start traveling from the thread clamping position to the thread releasing/thread waste retaining position can be changed. * This memory switch is displayed only for the LK-1900BBN, LK-1903BBN. 	-10 to 10 (In the range of -344° to 64° in increments of 4°)	0	
U085	Thread waste suction actuation time Length of time to be elapsed from the turning-ON to the turning-OFF of the thread waste suction device. * This memory switch is displayed only for the LK-1900BBN, LK-1903BBN. 	110 to 1000 ms	LK-1900BBN :110 LK-1903BBN :140	
U086	Thread waste suction actuation time Length of time to be elapsed from the turning-ON of the thread waste suction nozzle/thread waste suction to the turning-OFF of it * This memory switch is displayed only for the LK-1900BBN, LK-1903BBN. 	LK-1900BBN : 110 to 1000 ms LK-1903BBN : 140 to 1000 ms	LK-1900BBN :110 LK-1903BBN :140	
U087	Thread waste suction nozzle actuation time Length of time to be elapsed from the turning-ON of the thread waste suction nozzle to the turning-OFF of it * This memory switch is displayed only for the LK-1900BBN, LK-1903BBN. 	110 to 1000 ms	110	
U088	Number of stitches for releasing thread-waste Time lapse (i.e., the number of stitches to be sewn) from trimming of thread at the beginning of sewing to releasing of thread * This memory switch is displayed only for the LK-1900BBN, LK-1903BBN. 	0 to 100 stitches	LK-1900BBN :5 LK-1903BBN :0	
U089	Bird's nest suction time Time during which the thread tangling in at the beginning of sewing (so-called bird's nest) is being sucked * This memory switch is displayed only for the LK-1900BBN, LK-1903BBN. 	100 to 1000 ms	100	
U090	Rest time to the start of suction of bird's nest Time lapse from trimming of shorter thread remaining on the material to suction of thread tangling in at the beginning of sewing * This memory switch is displayed only for the LK-1903BBN. 	80 to 500 ms	80	
U239	Choice of language. With this switch, the language to be displayed on the panel is selected. * The number of selectable languages differs with the type of sewing machine shipped English : Not yet selected (display in English) 日本語 : Japanese English : English 中文 简体字 : Chinese (simplified characters) 中文 繁體字 : Chinese (traditional Chinese) Español : Spanish Italiano : Italian Français : French Deutsch : German Português : Portuguese Türkçe : Turkish Tiếng Việt : Vietnamese 한국어 : Korean Indonesia : Indonesian Русский : Russian	-	Not yet selected (display in English)	
U245	Grease-up needle. 	0 to 120000000 (Stitches) (Cannot be set)		The number of stitches can be cleared by keeping the RESET key held pressed.

9. OTHERS

9-1. Table of the standard pattern specifications

No.	Lengthwise	Crosswise	Number of stitches	Pattern	S, F, H	M
1 (51)	2.0	16	42	Large size bartacking	*	
2	2.0	10	42	Large size bartacking	*	
3	2.5	16	42	Large size bartacking	*	
4	3.0	24	42	Large size bartacking		
5	2.0	10	28	Large size bartacking	*	
6	2.5	16	28	Large size bartacking	*	
7	2.0	10	36	Large size bartacking	*	
8	2.5	16	36	Large size bartacking	*	
9	3.0	24	56	Large size bartacking		
10	3.0	24	64	Large size bartacking		
11	2.5	6	21	Small size bartacking (eyelet)	*	
12	2.5	6	28	Small size bartacking (eyelet)	*	
13	2.5	6	36	Small size bartacking (eyelet)	*	
14	2.0	8	14	Knit goods bartacking	*	*
15	2.0	8	21	Knit goods bartacking	*	*
16	2.0	8	28	Knit goods bartacking	*	*
17	0	10	21	Straight line bartacking	*	
18	0	10	28	Straight line bartacking	*	
19	0	25	28	Straight line bartacking		
20	0	25	36	Straight line bartacking		
21	0	25	41	Straight line bartacking		
22	0	35	44	Straight line bartacking		
23	20	4.0	28	Lengthwise bartacking		
24	20	4.0	36	Lengthwise bartacking		
25	20	4.0	42	Lengthwise bartacking		
26	20	4.0	56	Lengthwise bartacking		
27	20	0	18	Lengthwise straight line bartacking		
28	10	0	21	Lengthwise straight line bartacking		
29	20	0	21	Lengthwise straight line bartacking		
30	20	0	28	Lengthwise straight line bartacking		
38	2.0	8	28	Knit goods bartacking	*	*

In the condition of delivery from the factory, the pattern sewing with * marks can be made.

When using the standard patterns other than the patterns with * marks, refer to **"I.6-9. Setting enable/disable of standard pattern invoking" p.46** described in the item of the how to use the memory switch.

9-2. Table of the standard patterns

	No.	Stitch diagram	Number of stitches	Sewing size (mm)		(Note 2) No. of work clamp foot
				Length-wise	Cross-wise	
Large size bartacking	1 (51)		42	2.0	16	1
	2					2
						3
	3 ※		2.5	16	1	
					4	
	4 ※		3.0	24	6	
					7	
	5		2.0	10	1	
					2	
	6 ※		2.5	16	1	
4						
7		2.0	10	1		
				2		
8 ※		2.5	16	1		
				4		
9 ※		3.0	24	6		
				7		
10 ※		3.0	24	6		
				7		
Small size bartacking	11		21	2.5	6	8
	12		28	2.5	6	
	13		36	2.5	6	
Knit goods bartacking	14		14	2.0	8	5
	15		21	2.0	8	
	16		28	2.0	8	
Straight line bartacking	17		21	0	10	1
	18					2
						3
	19		0	25	6	
					7	
	20		36	0	25	6
						7
	21		41	0	25	6
						7
	22		44	0	35	(Note3)
Lengthwise bartacking	23		28	20	4.0	9
	10					
	24		36	20	4.0	9
	10					
	25		42	20	4.0	9
	10					
26		56	20	4.0	9	
10						
Lengthwise straight line bartacking	27		18	20	0	11
	28					
	28		21	10	0	
	29					
29		21	20	0		
30						
30		28	20	0		

- (Note) 1. Sewing size shows the dimensions when the scale rate is 100%.
 2. Refer the No. of work clamp foot to the separate table of work clamp foot.
 3. For No. 22, process the work clamp foot blank for use.
 4. Use the patterns with ※ marks for sewing denim.
 5. No. 51 is for the machine without thread clamp device.

	No.	Stitch diagram	Number of stitches	Sewing size (mm)		(Note 2) No. of work clamp foot
				Length-wise	Cross-wise	
Semi-lunar bartacking	31		52	7	10	13
	32		63	7	12	13
	33		24	6	10	13
	34		31	6	12	13
	35		48	10	7	14
	36		48	10	7	14
Large size bartacking	37		90	3	24	6
						7
Knit goods bartacking	38		28	2	8	5
Round bartacking	39		28	ø12		16
	40		48			

Pattern Nos. 41 to 46 are for the optional work clamp foot No. 12. The origin of the patterns is different by 5 mm up and down from that of lengthwise bartacking pattern Nos. 23 to 26.



	No.	Stitch diagram	Number of stitches	Sewing size (mm)		(Note 2) No. of work clamp foot	
				Length-wise	Cross-wise		
Lengthwise bartacking	41		29	20	2.5	12	
	42		39	25	2.5	12	
	43		45	25	2.5	12	
	44		58	30	2.5	12	
	45		75	30	2.5	12	
	46		42	30	2.5	12	
	Radial bartacking	47		91	ø8		15
		48		99			
		49		148			
		50		164			

9-3. Table of the work clamp foot

	1	2	3	4	5
Work clamp foot	13518659 (asm.)			13548557 (asm.)	13542964 (asm.)
Feed plate	14116107	14116404	14116800	14116305	14116206
	(With knurl)	(Without knurl)	(Without knurl)	(With knurl)	(With knurl)
Sewingspecification	S	F	F	H / W	M
※ Finger guard	13533104				
Remarks	Standard accessory for S (standard) type machine head.	Supplied with F (foundation) type machine head. (Depends on the destination)		Optional	Standard accessory for M (knit goods) type machine head.

※ Install a finger guard suitable for each work clamp foot when replacing the work clamp foot.

	6	7	8	9	10	11
Work clamp foot	13548151(asm.)		13542451 (asm.)	13571955 (asm.)		13561360 (asm.)
Feed plate	13548003 (With knurl)	13554803 (With knurl)	14116602 (With knurl)	14116503 (Without knurl)	14116909 (Without knurl)	14116701 (Without knurl)
Sewing specification	S	H / W	S	F	F	F
※ Finger guard	13548300		13533104	13573407		
Remarks	Optional	Standard accessory for H type (Heavy-weight material) and W type(Double-capacity hook) machine head.	Optional	Accessory part for F (foundation) type. (Depends on the destination)		Optional

	12	13	14	15	16
Work clamp foot	14137509 (right) 14137608 (left)	40021871 (right) 40021872 (left)	40021874 (right) 40021875 (left)	40021877 (right) 40021878 (left)	40021880 (right) 40021881 (left)
Feed plate	14137707 (Without knurl)	40021873 (With knurl)	40021876 (With knurl)	40021879 (With knurl)	40021882 (With knurl)
Sewing specification	F	S	S	S	S
※ Finger guard	14135305	13533104			
Remarks	Optional	Optional	Optional	Optional	Optional

※ Install a finger guard suitable for each work clamp foot when replacing the work clamp foot.

9-4. Installing the foot pedal switch (optional)



DANGER :

To prevent personal injuries caused by electric shock hazards or abrupt start of the sewing machine, carry out the work after turning OFF the power switch and a lapse of 5 minutes or more. To prevent accidents caused by unaccustomed work or electric shock, request the electric expert or engineer of our dealers when adjusting the electrical components.

The hand switch is provided on the standard type machine.

To use the optional foot pedal switch (part number: GPK570010B0), connect it in the procedure described below. When installing the foot pedal switch, the foot pedal switch junction cable asm. (part number: M90135900A0) is also required. Refer to "[I.9-8. Table of the optional parts](#)" p.76

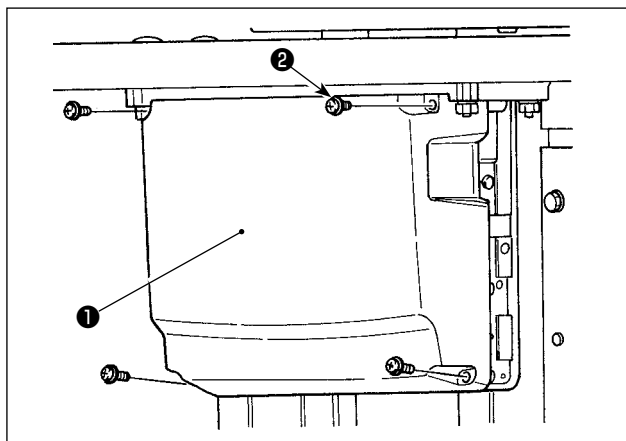

- 1) Loosen the four setscrews ② in the control box to remove cover ① .

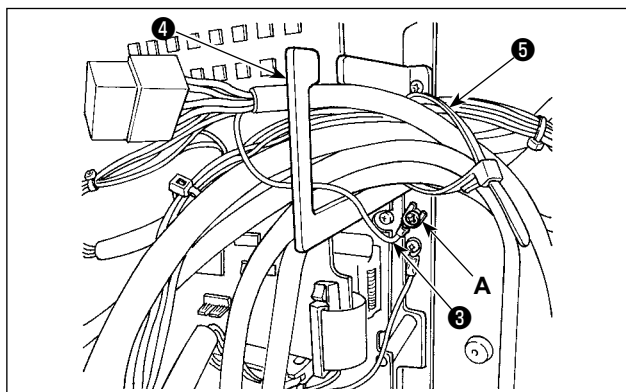

- 2) Fix earthing wire ③ of the foot pedal switch at location A of the control box.

Caution Pass the earthing wire ③ through cord exit plate ④ . If not, it can be caught under the cover when closing it.

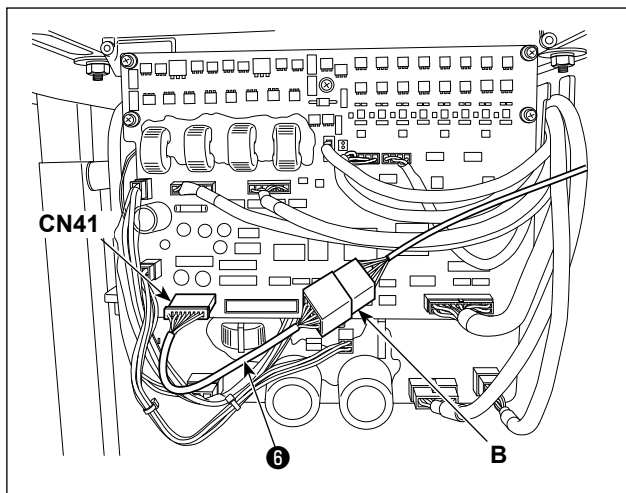

- 3) Connect foot pedal switch junction cable ⑥ to the foot pedal switch cable (B) and connect the opposite side of the junction cable to CN41 connector on the PWB.













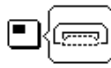

- 4) Loosen cable clip band ⑤ . Fix the foot pedal switch cables (excluding earthing wire ③) by means of cable clip band ⑤ together with other related cables.











DANGER :

















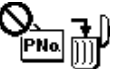
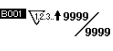







It is very important to carefully connect the cables to the correct connectors on the PWB. Wrong connection poses a great risk.





9-5. Error list

Error code	Indication	Description of error	Corrective measure	Remarks
E007		Machine lock error The main shaft of the sewing machine does not rotate due to some troubles.	Turn OFF the power switch and remove the cause of troubles.	
E010		Pattern No. error Back-uped pattern No. has not been registered in the data ROM, or it is set to readout inoperative. Pattern No. is set to "0".	Press the reset key and check the pattern No. Check the contents of memory switch No. 201.	
E011		External media not inserted USB thumb drive is not inserted.	Re-operation is enabled after resetting.	
E012		Read error Data cannot be read from the USB thumb drive.	Re-operation is enabled after resetting.	
E013		Write error Data cannot be written on the USB thumb drive.	Re-operation is enabled after resetting.	
E014		Write-protect USB thumb drive is write-protected.	Re-operation is enabled after resetting.	
E015		Format error USB thumb drive cannot be formatted.	Re-operation is enabled after resetting.	
E016		External media capacity over Memory capacity of the USB thumb drive to write pattern data is not sufficient.	Re-operation is enabled after resetting.	
E017		Machine memory capacity over Memory capacity of the sewing machine to write pattern data is not sufficient.	Re-operation is enabled after resetting.	
E019		File size over The pattern data to be read from the USB thumb drive is too large. (Max.: Approximately 20000 stitches)	Re-operation is enabled after resetting.	
E022		File No. error There is no designated file in the external media.	Possible to recover by reset.	Previous screen
E024		Pattern data size over The pattern data to be written on the sewing machine memory is too large. (Max.: Approximately 20000 stitches)	Re-operation is enabled after resetting.	
E030		Needle bar position error Needle bar is not in the specified position.	Turn the hand pulley to return the needle bar to its specified position.	
E031		Air pressure drop Air pressure is dropped.	Supply air and reset the sewing machine. Then, the operation is enabled again.	



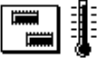
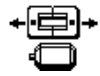
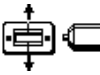

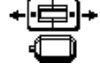
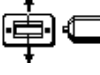
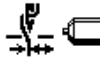



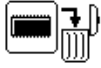
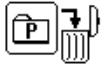
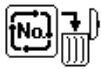

Error code	Indication	Description of error	Corrective measure	Remarks
E040		Sewing area over The sewing area is beyond the limit.	Press the reset key and check the pattern and X/Y scale rate.	This error is output when max. sewing area, 30 x 40 is over. Interference of the work clamp foot with needle is not protected.
E043		Enlargement error The sewing pitch is beyond 10 mm.	Press the reset key and check the pattern and X/Y scale rate.	
E045		Pattern data error The pattern data cannot be adopted.	Re-operation is enabled after resetting.	
E050		Temporary stop Temporary stop by operating the reset key while the sewing machine is running. (Refer to memory switch No. 31.)	Re-start or return-to-origin after thread trimming by means of the reset key (For the details, refer to the item " I.6-4. How to use the temporary stop " p.38.)	
E061		Memory switch data error Memory switch data is broken or revision is old.	Re-operation is enabled after resetting.	
E063	TYPE 	Machine head identification error The type of machine head and the type of control box do not match.	Turn the power OFF and contact JUKI or your distributor.	
E204		Connection alert for the USB thumb drive which is used for sewing Sewing has been carried out by 10 or more times with the USB thumb drive inserted in the USB port.	Re-operation is enabled after resetting.	
E220	100000000 	Grease replenishing time information Information as to the time of replenishing the designated places with grease Refer to " I.7-10. Replenishing the designated places with grease " p.54.	Replenish the designated places with grease and set memory switch No. 245 to "0" with the RESET key. Error can be released with the RESET key when immediate replenishing with grease cannot be performed during sewing operation.	
E221	120000000 	Grease replenishing warning error Sewing machine has stopped since the time of replenishing the designated places with grease has come. Refer to " I.7-10. Replenishing the designated places with grease " p.54.	Immediately perform replenishing with grease and set memory switch No. 245 to "0" with the RESET key.	
E302		Head tilt error Head tilt detection switch is turned OFF.	The sewing machine cannot be operated with the head tilted. Return the sewing machine head to its proper position.	

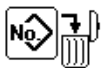





Error code	Indication	Description of error	Corrective measure	Remarks
E303		Z phase detection error Detection of the upper dead point of the sewing machine cannot be performed.	Turn OFF the power switch. Check whether the pin of the SDC board CN15 has come off or has loosened.	
E305		Thread trimmer position error The thread trimmer is not in the proper position.	Turn OFF the power switch and check whether CN72 has come off or has loosened.	
E396		Shorter-thread remaining type thread trimmer cylinder error The shorter-thread remaining thread trimmer cylinder fails to operate. (The shorter-thread remaining type thread trimmer cylinder sensor fails to turn OFF when the cylinder operates.)	Turn OFF the power switch. Check whether the air pressure is adequate and whether the shorter-thread remaining thread trimming cylinder sensor and MAIN PCB CN53 have loosened or fallen off.	
E397		Suction nozzle cylinder error The suction nozzle cylinder fails to operate. (The suction nozzle cylinder sensor fails to turn OFF when the cylinder operates.)	Turn OFF the power switch. Check whether the air pressure is adequate and whether the suction nozzle cylinder sensor and MAIN PCB CN54 have loosened or fallen off.	
E398		Shorter-thread remaining type thread trimmer cylinder sensor error The shorter-thread remaining type thread trimmer cylinder sensor fails to detect.	Turn OFF the power switch. Check whether the air pressure is adequate and whether the shorter-thread remaining thread trimming cylinder sensor and MAIN PCB CN53 have loosened or fallen off.	
E399		Suction nozzle cylinder sensor error The suction nozzle cylinder sensor fails to detect.	Turn OFF the power switch. Check whether the air pressure is adequate and whether the suction nozzle cylinder sensor and MAIN PCB CN54 have loosened or fallen off.	
E405		Prohibition of deletion of direct patterns The direct pattern is set in the cycle sewing data.	Re-operation is enabled after resetting.	
E430		Counter set-value is reached The set value of the counter is reached. * For the type of counter and the counter value displayed depends on the predetermined counter.	Re-operation is enabled after resetting.	
E730		Encoder trouble A Encoder A or B phase cannot be detected.	Turn OFF the power switch. Check whether the pin CN15 has come off or has loosened.	
E731		Encoder trouble B Encoder U, V or W phase cannot be detected.	Turn OFF the power switch. Check whether the pin CN15 has come off or has loosened.	
E733		Reverse rotation of motor The motor is reversing.	Turn OFF the power switch and check whether coupling of the main motor is loose.	

Error code	Indication	Description of error	Corrective measure	Remarks
E811		Overvoltage error Power source voltage is beyond the specified value.	Check the power supply voltage.	
E813		Low voltage error Power source voltage is short.	Check the power supply voltage.	
E901		Motor driver trouble Error from the motor driver is detected.	Turn OFF the power switch and turn ON the power switch again after some time.	
E903		Stepping motor power supply trouble Power source of the stepping motor is not output.	Turn OFF the power switch and check F1 fuse of SDC board.	
E904		Solenoid power supply trouble Power source of the solenoid is not output.	Turn OFF the power switch and check F2 fuse of SDC board.	
E905		SDC board overheat Overheat of SDC board	Turn OFF the power switch and turn ON the power switch again after some time.	
E907		X origin retrieval error X origin sensor does not change.	Turn OFF the power switch and check whether CN62 of INT board or CN42 of MAIN board is disconnected or loose.	
E908		Y origin retrieval error Y origin sensor does not change.	Turn OFF the power switch and check whether CN63 of INT board or CN43 of MAIN board is disconnected or loose.	
E910		Work clamp foot origin retrieval error Work clamp foot origin sensor does not change.	Turn OFF the power switch and check whether CN71 of INT board or CN44 of MAIN board is disconnected or loose.	
E913		Needle thread clamp origin retrieval error Needle thread clamp origin sensor does not change.	Turn OFF the power switch and check whether CN77 of INT board or CN45 of MAIN board is disconnected or loose.	
E914		Feed trouble error Timing lag between feed and main shaft has occurred.	Turn OFF the power switch and check whether coupling of the main motor is loose.	
E915		Communication error between panel and MAIN Communication between the panel and MAIN cannot be performed.	Turn OFF the power switch and check whether CN34 of MAIN board is disconnected or loose.	
E916		Communication error between MAIN and SDC Communication between MAIN and SDC cannot be performed.	Turn OFF the power switch and check whether CN32 of MAIN board or CN15 of SDC board is disconnected or loose.	

Error code	Indication	Description of error	Corrective measure	Remarks
E918		MAIN board overheat Overheat of MAIN board	Turn OFF the power switch and turn ON the power switch again after some time.	
E926		X motor displacement error X feed motor is out of position.	Turn OFF the power.	
E927		Y motor displacement error Y feed motor is out of position.	Turn OFF the power.	
E929		Needle thread clamp motor displacement error Needle thread clamp motor is out of position.	Turn OFF the power switch and check whether CN45 of MAIN board is disconnected or loose.	
E931		X motor overload error The load applied to the X feed motor is excessive.	Turn OFF the power.	
E932		Y motor overload error The load applied to the Y feed motor is excessive.	Turn OFF the power.	
E934		Thread clamp motor overload error The load applied to the thread clamp motor is excessive.	Turn OFF the power.	
E943		MAIN memory write-in trouble Memory write-in of MAIN board cannot be performed.	Turn OFF the power switch and check the insertion of ROM of U022 of MAIN board.	
E946		INT memory write-in trouble Memory write-in of the head board cannot be performed.	Turn OFF the power switch and check whether CN30 of MAIN board is disconnected or loose.	
-		Power supply fault, connector disconnection The supply voltage specification is not correct. The connector has dropped off.	Turn OFF the power switch. Check the supply voltage, and check the CN3 of the FLT board and CN13 of the SDC board is disconnected or loose.	

9-6. Message list

Message No.	Display	Display message	Description
M520		Erase is performed. OK ?	Erase confirmation of Users' pattern
M521		Erase is performed. OK ?	When deletion of the direct pattern is checked
M522		Erase is performed. OK ?	Erase confirmation cycle pattern
M523		Pattern data is not stored in memory. Erase is OK ?	Erase confirmation of backup data
M524		Erase is performed. OK ?	When deletion (of pattern data) is checked on the communication screen
M525		Erase is performed. OK ?	When deletion (of machine data) is checked on the communication screen
M528		Overwriting is performed. OK ?	Overwriting confirmation of users' pattern
M529		Overwriting is performed. OK ?	Overwriting confirmation of media
M530		Overwriting is performed. OK ?	When overwrite is checked on the communication screen (Panel + pattern data)
M531		Overwriting is performed. OK ?	When overwrite is checked on the communication screen (Media+ pattern data)
M533		Overwriting is performed. OK ?	When overwrite is checked on the communication screen (Panel + machine data)
M537		Deleting is performed. OK ?	When deletion of (thread tension) data is checked on the communication screen
M542		Formatting is performed. OK ?	Format confirmation

Message No.	Display	Display message	Description
M547		Overwriting cannot be performed since data exists.	Overwrite is disabled (panel)
M548		Overwriting cannot be performed since data exists.	Overwrite is disabled (media)
M581		Registration is canceled.	Registration of a direct pattern
M582		Copy is cancelled.	Exited from the pattern data screen without copying
M583		Copy is cancelled.	Exited from the direct pattern screen without copying
M584		Copy is cancelled.	Exited from the cycle pattern screen without copying

9-7. Troubles and corrective measures (sewing conditions)

Trouble	Cause	Corrective measures	Page
1. The needle thread slips off at the start of bar-tacking.	① Stitches are slipped at the start.	○ Adjust the clearance between the needle and the shuttle to 0.05 to 0.1 mm.	50
	② The needle thread remaining on the needle after thread trimming is too short.	○ Set soft-start sewing at the start of bartacking.	56
	③ The bobbin thread is too short.	○ Correct the thread tension release timing of the thread tension controller No. 2.	17
	④ Needle thread tension at 1st stitch is too high.	○ Increase the tension of the thread take-up spring, or decrease the tension of the thread tension controller No. 1.	
	⑤ Thread clamp is unstable (material is apt to be expanded, thread is hard to slide, thread is thick, etc.).	○ Decrease the tension of the bobbin thread.	16
	⑥ Pitch at 1st stitch is too small.	○ Increase the clearance between the needle hole guide and the counter knife.	51
2. Thread often breaks or synthetic fiber thread splits finely.	① The shuttle or the driver has scratches.	○ Decrease the tension at 1st stitch.	51
	② The needle hole guide has scratches.	○ Decrease the number of rotation at 1st stitch at the sewing start. (Extent of 600 to 1,000 sti/min)	
	③ The needle strikes the work clamp foot.	○ Increase the number of stitches of thread clamp to 3 to 4 stitches.	16
	④ Fibrous dust is in the groove of the shuttle race.	○ Make the pitch at 1st stitch longer.	
	⑤ The needle thread tension is too high.	○ Decrease the needle thread tension at 1st stitch.	17
	⑥ The tension of the thread take-up spring is too high.		15
	⑦ The synthetic fiber thread melts due to heat generated on the needle.	○ Use silicone oil.	
3. The needle often breaks.	① The needle is bent.	○ Replace the bent needle.	14
	② The needle hits the work clamp foot.	○ Correct the position of the work clamp foot.	51
	③ The needle is too thin for the material.	○ Replace it with a thicker needle according to the material.	50
	④ The driver excessively bends the needle.	○ Correctly position the needle and the shuttle.	
	⑤ Needle thread is stepped on by the work clamp foot at the start of sewing. (Needle bend)	○ Widen the distance between the needle and the wiper. (23 to 25 mm)	52
4. Threads are not trimmed. (Bobbin thread only)	① The counter knife is dull.	○ Replace the counter knife.	51
	② The difference in level between the needle hole guide and the counter knife is not enough.	○ Increase the bend of the counter knife.	
	③ The moving knife has been improperly positioned.	○ Correct the position of the moving knife.	50
	④ The last stitch is skipped.	○ Correct the timing between the needle and the shuttle.	
	⑤ Bobbin thread tension is too low.	○ Increase the bobbin thread tension.	

Trouble	Cause	Corrective measures	Page
5. Stitch skipping often occurs.	① The motions of the needle and shuttle are not properly synchronized.	○ Correct the positions of the needle and shuttle.	50
	② The clearance between the needle and shuttle is too large.	○ Correct the positions of the needle and shuttle.	50
	③ The needle is bent.	○ Replace the bent needle.	14
	④ The driver excessively bends the needle.	○ Correctly position the driver.	50
6. The needle thread comes out on the wrong side of the material.	① The needle thread tension is not high enough.	○ Increase the needle thread tension.	16
	② The tension release mechanism fails to work properly.	○ Check whether or not the tension disc No. 2 is released during bar-tracking.	16
	③ The needle thread after thread trimming is too long.	○ Increase the tension of the thread tension controller No. 1.	
	④ Number of stitches is too few.	○ Turn OFF the thread clamp.	
	⑤ When sewing length is short (End of needle thread protrudes on the wrong side of sewing product.)	○ Turn OFF the thread clamp.	
	⑥ Number of stitches is too few.	○ Use the lower plate, the hole of which is larger than the presser.	
7. Threads break at time of thread trimming.	① The moving knife has been improperly position.	○ Correct the position of the moving knife.	
8. The thread clamp is entangled with needle thread.	① The needle thread at the sewing start is too long.	○ Tighten thread tension controller No. 1 and make the length of needle thread 33 to 36 mm.	
9. Uneven length of the needle thread	① The tension of thread take-up spring is too low.	○ Increase the tension of the thread take-up spring.	
10. The length of needle thread does not become short.	① The tension of thread tension controller No. 1 is too low.	○ Increase the tension of thread tension controller No. 1.	
	② The tension of thread take-up spring is too high.	○ Decrease the tension of thread take-up spring.	
	③ The tension of thread take-up spring is too low and motion is unstable.	○ Increase the tension of thread take-up spring and lengthen the stroke as well.	
11. The knotting section of bobbin thread at 2nd stitch at the sewing start appears on the right side.	① Idling of bobbin is large.	○ Adjust the position of the moving knife.	
	② The bobbin thread tension is too low.	○ Increase the bobbin thread tension.	
	③ The needle thread tension at 1st stitch is too high.	○ Decrease the needle thread tension at 1st stitch. ○ Turn OFF the thread clamp.	

9-8. Table of the optional parts

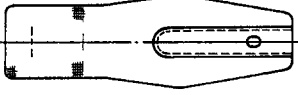
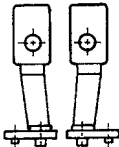
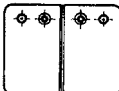
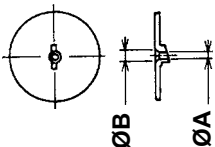
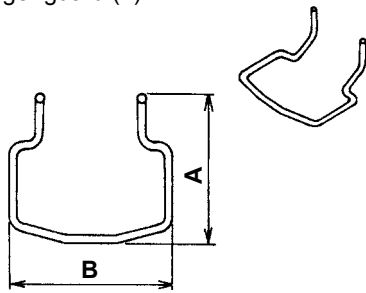
Name of Parts	Type	Part No.	Remarks
Feed plate blank  t = 1.2	Without knurl / processed Sewing area lengthwise 20 X crosswise 40	14120109	
	With knurl / processed Sewing area lengthwise 20 X crosswise 40	14120307	
	Without knurl / stainless steel Sewing area lengthwise 20 X crosswise 40	14120505	t = 0.5
	Without knurl / processed Sewing area lengthwise 30 X crosswise 40	40021855	
	Without knurl / without processing Sewing area lengthwise 30 X crosswise 40	40021856	
	Without knurl / stainless steel Sewing area lengthwise 30 X crosswise 40	40021857	t = 0.5
	With knurl / processed Sewing area lengthwise 30 X crosswise 40	40021858	
	With knurl / without processing Sewing area lengthwise 30 X crosswise 40	40021859	
	Work clamp foot face plate (asm.) 		14121263
Presser blank  t = 3.2	With knurl / Processed (right) Sewing area lengthwise 20 X crosswise 40	14121701	
	With knurl / Processed (Left) Sewing area lengthwise 20 X crosswise 40	14121800	
	With knurl / Processed (right) Sewing area lengthwise 30 X crosswise 40	40021851	
	With knurl / Processed (Left) Sewing area lengthwise 30 X crosswise 40	40021852	
	With knurl / without processing (right) Sewing area lengthwise 30 X crosswise 40	40021853	
	With knurl / without processing (Left) Sewing area lengthwise 30 X crosswise 40	40021854	
Needle hole guide  $\varnothing B$ $\varnothing A$	A=1.6 B=2.6 With relief slit	B2426280000	Standard type
	A=1.6 B=2.0 Without relief slit	D2426282C00	F and M types
	A=2.3 B=4.0 Without relief slit	14109607	H and W types
	A=2.7 B=3.7 Without relief slit	D2426MMCK00	For extra heavy-weight material
Finger guard (1)  A B	A=56.5 B=64	13533104	
	A=59 B=74	13548300	For large size bartacking

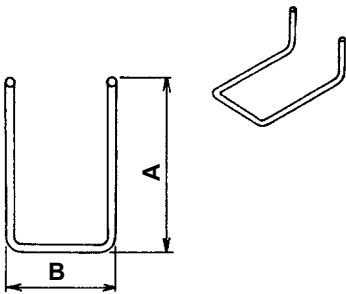
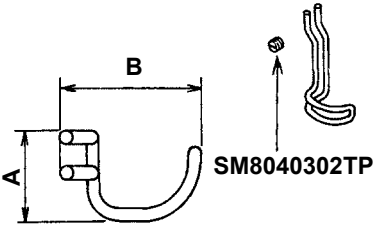
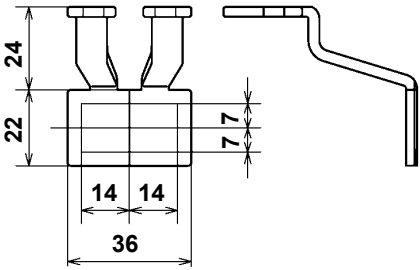
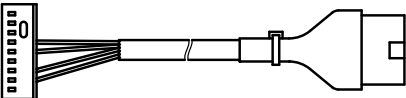
Name of Parts	Type	Part No.	Remarks
Finger guard (2) 	A=66.5 B=43	13573407	For lengthwise bartacking
Finger guard (3) 	A=21.5 B=35.5	14120000	For specially ordered work clamp
Work clamp foot blank 	With knurl / processed (right)	40021869	
	With knurl / processed (left)	40021870	
PK57 changing cable asm. 		M90135900A0	

II. EXPLANATION OF THE LK-1901BN, COMPUTER-CONTROLLED HIGH-SPEED EYELET BUTTONHOLE BARTACKING MACHINE

1. SPECIFICATIONS

Different specifications from those of the LK-1900BN only are described.

1	Max. sewing speed	3,000 sti/min
2	Needle	DPx5 #14, #16
3	Lift of the work clamp foot	Max. 17mm
4	Number of standard patterns	3 patterns

2. INSTALLATION OF THE SEWING MACHINE AND PREPARATION OF THE OPERATION



DANGER :

Be sure to perform the work with two persons or more when moving the sewing machine.

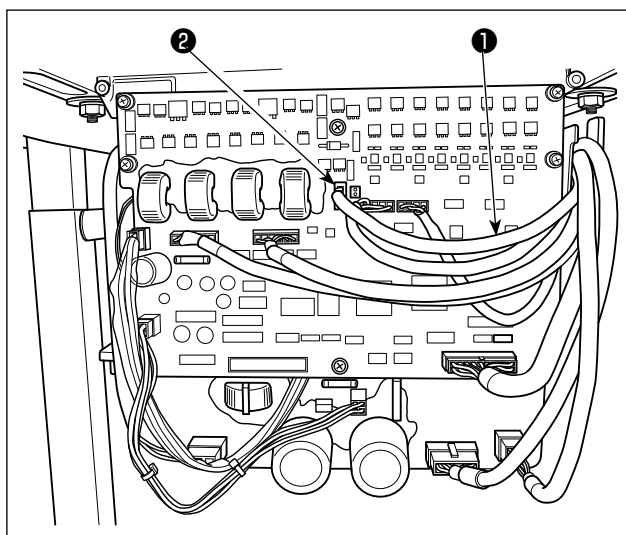

- 1) Except for the connection of the button clamp unit solenoid, installation of LK-1901BN and preparation of the operation are the same as those of the LK-1900BN.
Refer to the instruction manual for the LK-1900BN.
- 2) Connect connector CN47 ① of the relay cable of the button clamp unit with connector CN47 ② mounted on the MAIN board inside the control box.

3. PREPARATION OF THE SEWING MACHINE

3-1. Adjustment of the material closing amount



WARNING :

Turn OFF the power before starting the work so as to prevent accidents caused by abrupt start of the sewing machine.

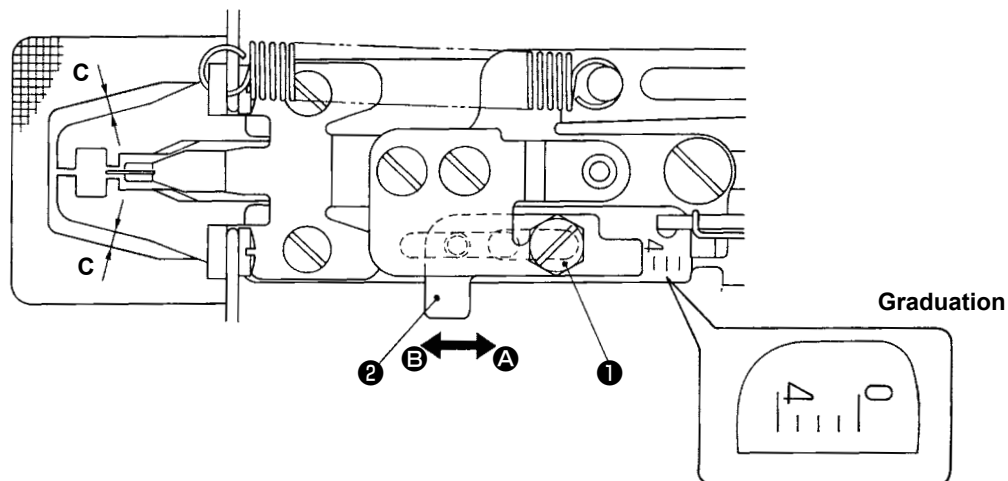

- 1) The maximum material closing amount is 4 mm. However, the amount is set to 2 mm at the time of delivery because of the relation of the feed plate window and the work clamp foot (dimension C). (Graduation position : 2)
- 2) Loosen bolt ① and move work clamp foot regulator ② in the direction of arrow to adjust the material closing amount. The material closing amount will be decreased when work clamp foot regulator ② is moved in the direction of A , and be increased when it is moved in the direction of B .



To increase the material closing amount more than 3 mm, widen the feed plate window by additional work (increase the dimension C.) so that the feed plate window does not interfere with the work clamp foot.

3-2. Adjustment of the lift of the work clamp foot



WARNING :

Turn OFF the power before starting the work so as to prevent accidents caused by abrupt start of the sewing machine.

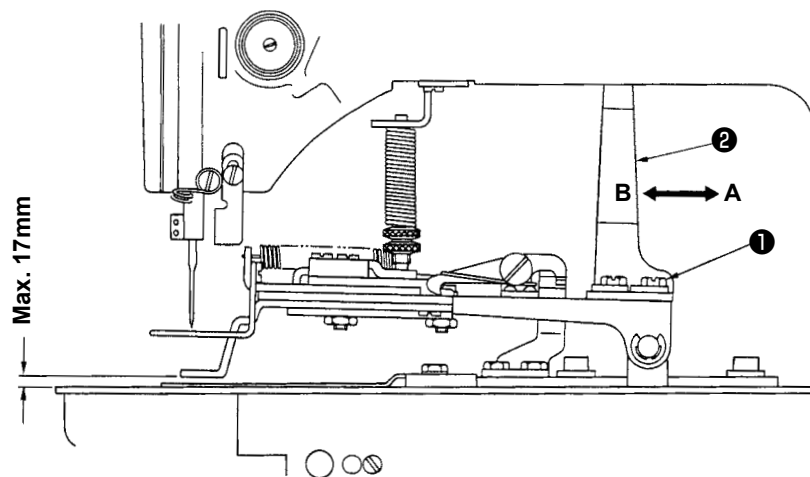

Loosen two setscrews ① and adjust by moving work clamp foot lifting plate ② back and forth in the direction of arrow. The amount of the lift of the work clamp foot will be decreased when work clamp lifting plate ② is moved in the direction of A , and be increased when it is moved in the direction of B . After the adjustment, securely tighten setscrews ① .

3-3. Adjustment of the pressure of the work clamp unit



WARNING :

Turn OFF the power before starting the work so as to prevent accidents caused by abrupt start of the sewing machine.

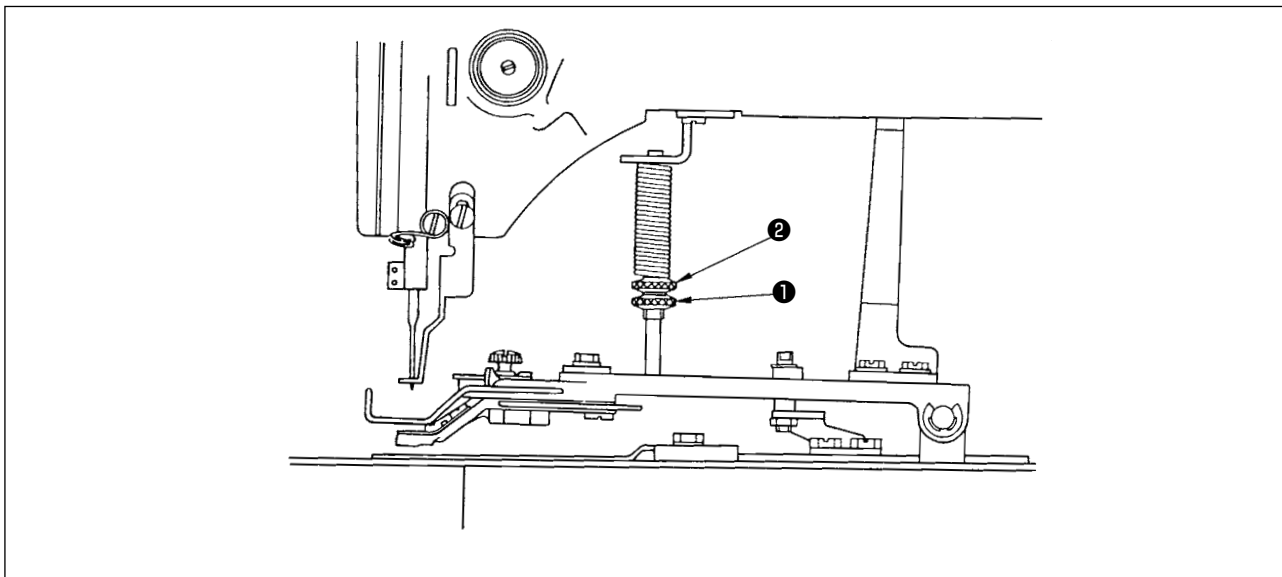

The pressure of the work clamp unit should be minimized as long as the material does not warp during sewing. Loosen adjusting screw ① and turn adjusting screw ② to obtain the aforementioned pressure.

3-4. Setting of the material closing operation

- 1) The material closing operation is performed by the electromagnetic solenoid, and change-over of the operation setting (effective / ineffective) is available. The material closing has been set to work simultaneously with sewing at the time of delivery.
- 2) If the material closing is not performed, the change-over is made by the memory switch. For the way of operation, refer to item **"1.8. HOW TO USE THE MEMORY SWITCH" p.56** described in the instruction manual for the LK-1900BN.

◎ List of memory switch functions

No.	Function	Setting range	State at time of delivery
U050	Setting of material closing operation	: Ineffective : Synchronized with work clamp foot : Synchronized with start	

※ Setting range “” : The material closing simultaneously works when the work clamp foot comes down.

Setting range “” : The material closing simultaneously works with the sewing after the work clamp foot has come down.

※ As for the contents of memory switch function Nos. other than memory switch No. 50, refer to the **"1.8-2. List of the memory switch functions" p.57** described in the Instruction Manual for the LK-1900BN.

4. OPERATION OF THE SEWING MACHINE

4-1. Selection and confirmation of the sewing patterns



WARNING :

In case of using an exclusive work clamp foot, make sure of the shape of the sewing pattern. If the sewing pattern extends outside the work clamp foot, the needle interferes with the work clamp foot during sewing, resulting in the danger of the needle breakage or the like.

- 1) The patterns for eyelet buttonhole bartacking are from No. 11 to No. 13.
- 2) When the material closing operation is performed, the maximum sewing size is 3x7mm. Set the most appropriate size using the enlargement/reduction function. As for the way of operation for setting, checking or changing the sewing pattern, refer to the item **"I.5. OPERATION OF THE SEWING MACHINE (BASIC)" p.17** described in the instruction material for the LK-1900BN.



After setting, check the needle entry point whether or not the needle interferes with the work clamp foot.

Pattern No.	Sewing size (mm)		Number of stitches
	Lengthwise	Crosswise	
11	2.5	6	21
12	2.5	6	28
13	2.5	6	36

Sewing size is the dimension when the enlargement rate is 100%.

III. EXPLANATION OF THE LK-1902B, COMPUTER-CONTROLLED HIGH-SPEED BELT-LOOP ATTACHING MACHINE

1. SPECIFICATIONS

Different specifications from those of the LK-1900BN only are described.

1	Max. sewing speed	3,000 sti/min
2	Needle	DPx5 #14, #16
3	Lift of the work clamp foot	Max. 17mm
4	Number of standard patterns	6 patterns

2. PREPARATION OF THE SEWING MACHINE

2-1. Threading the machine



WARNING :

Turn OFF the power before starting the work so as to prevent accidents caused by abrupt start of the sewing machine.

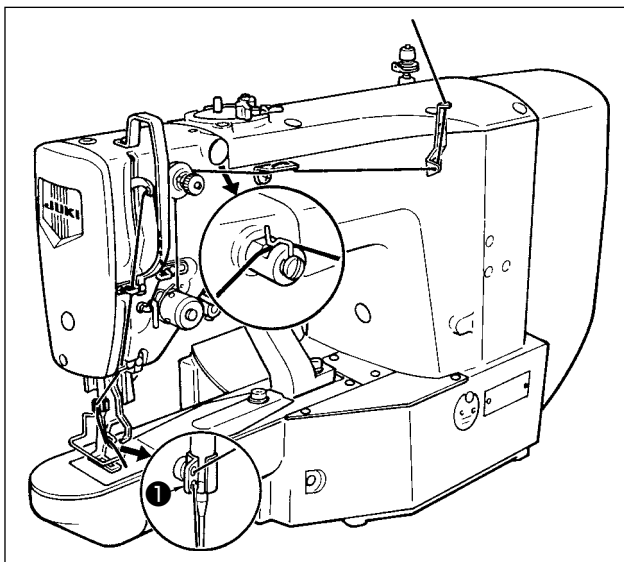

Thread the machine in the order as illustrated in the left figure. Leave thread of approximately 40 mm after passing through the needle.



For a thick thread, pass the thread through only one of the two holes in needle bar thread guide ①.

3. OPERATION OF THE SEWING MACHINE

3-1. Selection and confirmation of the sewing patterns



WARNING :

In case of using an exclusive work clamp foot, make sure of the shape of the sewing pattern. If the sewing pattern extends outside the work clamp foot, the needle interferes with the work clamp foot during sewing, resulting in the danger of the needle breakage or the like.

The patterns for the belt-loop attaching are from No. 17 to No. 22.

As for the way of operation for setting, checking or changing the sewing pattern, refer to the item **"I.5. OPERATION OF THE SEWING MACHINE (BASIC)" p.17** described in the instruction manual for the LK-1900BN.



After setting, make sure of the needle entry point whether or not the needle interferes with the work clamp foot.

* The calling has been set to ineffective at the time of delivery since the needle interferes with the standard work clamp foot which has been provided with the machine. When using this function, use "Setting the pattern data calling effective or ineffective" of the memory switch function to make the calling effective. As for the way of operation for setting, refer to the item **"I.8. HOW TO USE THE MEMORY SWITCH" p.56** described in the instruction manual for the LK-1900B.

Pattern No.	Sewing size (mm)		Number of stitches
	Lengthwise	Crosswise	
17	0	10	21
18	0	10	28
※ 19	0	25	28
※ 20	0	25	36
※ 21	0	25	42
※ 22	0	35	42

Sewing size is the dimension when the enlargement rate is 100%.

3-2. Combination of the work clamp foot and the feed plate



WARNING :

In case of using an exclusive work clamp foot, make sure of the shape of the sewing pattern. If the sewing pattern extends outside the work clamp foot, the needle interferes with the work clamp foot during sewing, resulting in the danger of the needle breakage or the like.

Make use of the appropriate combination of the work clamp foot and the feed plate in accordance with the sewing conditions. The combination for the standard delivery and the special order is shown in the following table.

Spec	Feed plate	Part No.	Work clamp foot	Part No.
LK-1902B Standard		13544465		14143002
For large size (Special order part)		13545660		13545504
For extra large size (Special order part)		13547161		13545801
				13547005

IV. EXPLANATION OF THE LK-1903BN, COMPUTER-CONTROLLED HIGH-SPEED LOCKSTITCH BUTTON SEWING MACHINE

1. SPECIFICATIONS

Different specifications from those of the LK-1900BN only are described.

1	Max. sewing speed	2,700 sti/min
2	Needle	DPx17 #14
3	Lift of the work clamp foot	Max. 13mm
4	Number of standard patterns	50 patterns

* The needle thread clamp device is set to prohibition (state of standard delivery) with memory switch U035. Refer to "1.5-8. Thread clamp device" p.24.

2. PREPARATION OF THE SEWING MACHINE

2-1. Installation of the sewing machine and preparation of the operation



DANGER :

Be sure to perform the work with two persons or more when moving the sewing machine.

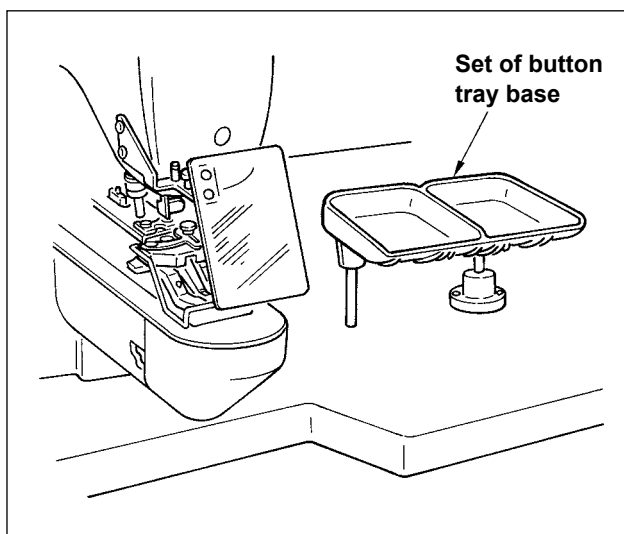

- 1) Installation of the sewing machine head and the control box is the same as that of the LK-1900BN. Refer to the instruction manual for the LK-1900BN.
- 2) Install a set of the button tray base to a convenient place for the work as the set is included in the accessories.
- 3) The way of operation is the same as that of the LK-1900B.

2-2. Needle and thread

Needle	Needle thread	Bobbin thread
DPx17 #14	#60	#80
	#60	#60
	#50	#60
	#40	#60

Needle and thread will vary in accordance with the sewing conditions. When using the needle and the thread, select them referring to the left table. Cotton thread and polyester spun thread are recommended.

2-3. Various sewing modes

(1) List of sewing patterns

Number of threads and standard sewing size of X and Y are as shown in the following list.

< Sewing program list >

Pattern No.	Stitch shape	Number of threads (thread)	Standard sewing size X (mm)	Standard sewing size Y (mm)	Pattern No.	Stitch shape	Number of threads (thread)	Standard sewing size X (mm)	Standard sewing size Y (mm)
1 • 34		6-6	3.4	3.4	18 • 44		6	3.4	0
2 • 35		8-8			19 • 45		8		
3		10-10			20		10		
4		12-12			21		12		
5 • 36		6-6			22		16		
6 • 37		8-8			23 • 46		6	0	3.4
7		10-10			24		10		
8		12-12			25		12		
9 • 38		6-6			26 • 47		6-6	3.4	3.4
10 • 39		8-8			27		10-10		
11		10-10			28 • 48		6-6		
12 • 40		6-6			29		10-10		
13 • 41		8-8			30 • 49		5-5-5	3.0	2.5
14		10-10			31		8-8-8		
15 • 42		6-6			32 • 50		5-5-5		
16 • 43		8-8			33		8-8-8		
17		10-10							

* The standard sewing sizes of X and Y are when the enlargement / reduction rate is 100%.
Use the pattern No. 34 to No.50 when the button hole is small (ø1.5 mm or less).

(2) Selection of the sewing pattern and the sewing width

- Selection of the sewing pattern is the same as that of the LK-1900BN.
- When the distance between holes of the button used does not fit the standard sewing width of the sewing pattern No., adjust the sewing width by enlarging/reducing the sewing width.
The way of enlarging/reducing is the same as that of the LK-1900BN. Refer to the table given below for the scale for enlargement/reduction in terms of the sewing width.
- After changing the sewing pattern No. and the sewing width, make sure of the needle entry point.
As for the way of confirmation, refer to the **"I.5-4. Checking the contour of a sewing pattern" p.21** in the instruction manual for the LK-1900BN.

◎ Table of XY scale in terms of the sewing width

X*Y (mm)	2.4	2.6	2.8	3.0	3.2	3.4	3.6	4.0	4.3	4.5	4.7	5.2	5.6	6.0	6.2	6.4
%	71	76	82	88	94	100	106	118	126	132	138	153	165	176	182	188

3. ADJUSTMENT OF THE SEWING MACHINE

3-1. Position of the button clamp jaw lever

WARNING :

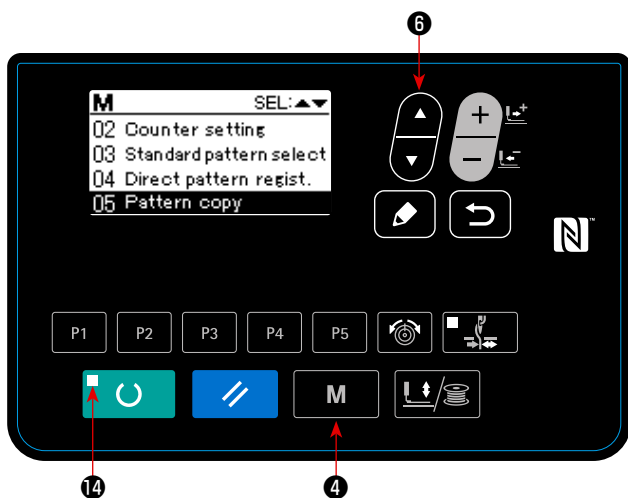
 When change of the shape of button, change of the sewing pattern or enlargement/reduction of the sewing width is performed, make sure the needle entry point. If the needle extends outside the button hole or the sewing pattern extends outside the button clamp unit, the needle interferes with the button hole or the button clamp unit, resulting in the danger of the needle breakage or the like.

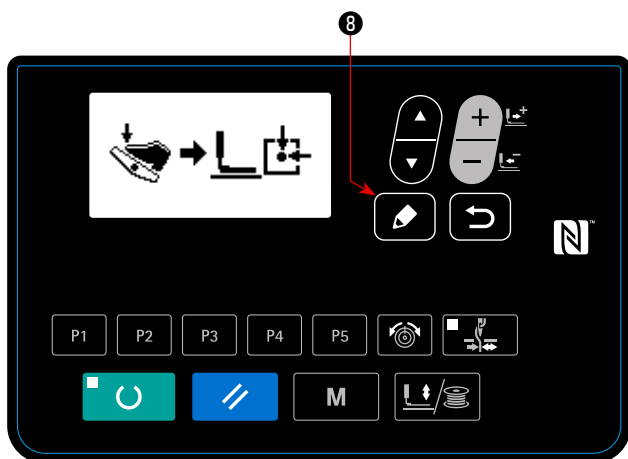

1) Press MODE key **M** 4 in the state where sewing LED 14 goes out on the operation panel.

2) Put "08 Work clamp adjustment" in the selected state with ITEM SELECT key 6.



3) Press EDIT key 8. The button clamp unit travels to the origin and goes up.

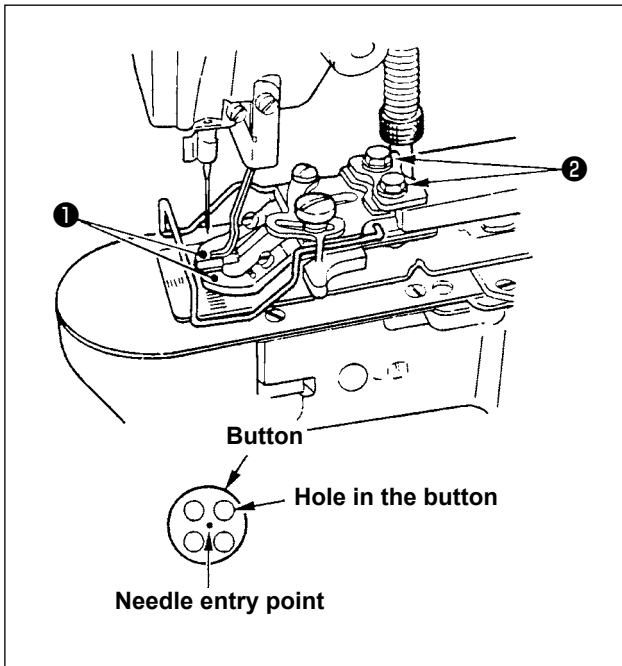

- 4) Place a button in button clamp jaw levers ❶ .
- 5) Depress the pedal to the first step and detach your foot from the pedal when the button clamp unit comes down.
- 6) Turn the hand pulley and check that the center of the needle enters the center of the button.
- 7) If the center of the needle is not located in the center of the button, loosen screws ❷ in the button clamp jaw lever base to adjust so that the center of the needle enters the center of the button.
- 8) When depressing the pedal to the second step at step 5), the button clamp unit moves again to the origin position. In addition, when the button clamp unit comes down, depress the pedal to the first step and detach the foot from the pedal. Then the button clamp unit goes up.
- 9) After the adjustment, perform the confirmation of the pattern shape and make sure that the needle surely has entered the button hole.

3-2. Adjusting the feed plate



WARNING :

When change of the shape of the button, change of the sewing pattern or enlargement/reduction of the sewing width is performed, make sure of the shape of the sewing pattern. If the feed plate interferes with the needle hole guide, it will result in the danger of the needle breakage or the like. Also, if the pedal is depressed during the adjustment, the button clamp unit will go up or come down. So, be careful.

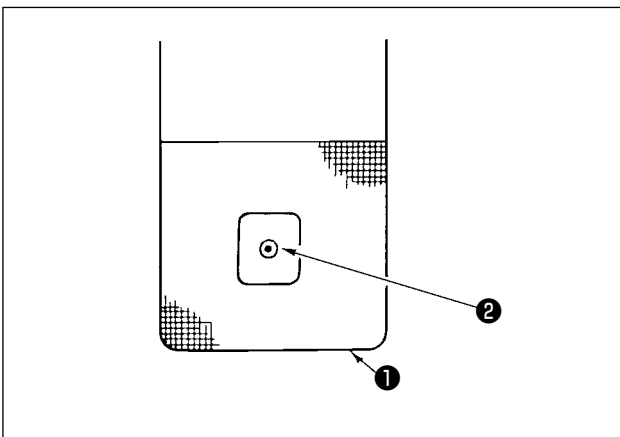

- 1) Put "08 Work clamp adjustment" in the selected state, referring to 1) and 2) in ["IV.3-1. Position of the button clamp jaw lever" p.86](#).
- 2) Press EDIT key  . The button clamp unit goes to the origin position and goes up.
- 3) Adjust feed plate ❶ so that needle hole guide ❷ comes to the center of the recessed part of feed plate ❶ .

3-3. Adjusting the button clamp jaw lever



WARNING :

Turn OFF the power before starting the work so as to prevent accidents caused by abrupt start of the sewing machine.

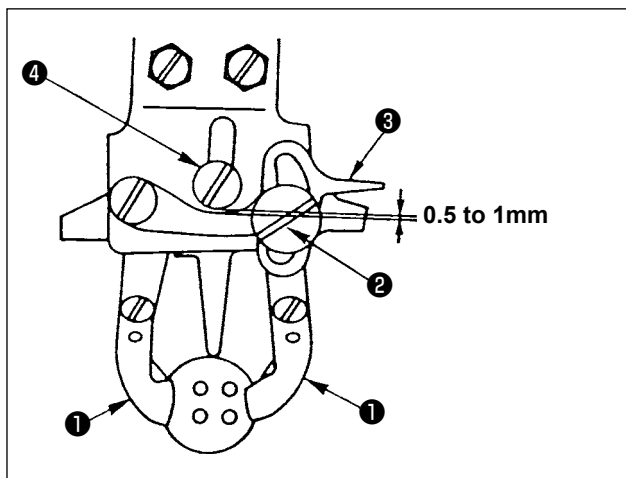

Bring the machine to its stop-motion state. Then lift button clamp ① . Loosen screw ② in the button clamp jaw lever and adjust so that a clearance of 0.5 to 1 mm is provided between button clamp jaw lever ③ and hinge screw ④ when placing a button in between button clamps ① . Then tighten screw ② in the button clamp jaw lever.

3-4. Adjusting the lifting amount of the button clamp



WARNING :

Turn OFF the power before starting the work so as to prevent accidents caused by abrupt start of the sewing machine.

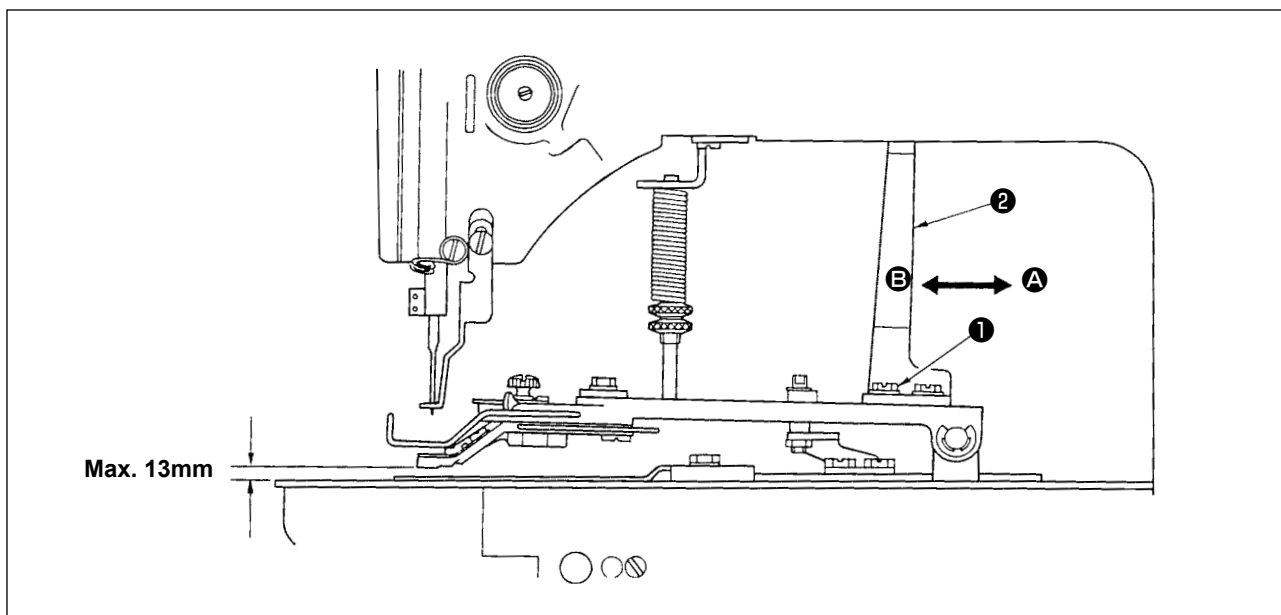

Loosen two setscrews ① , and move moving plate ② back and forth in the direction of arrow to adjust. The lifting amount of the button clamp will be decreased when moving plate ② is moved in the direction of A , and be increased when it is moved in the direction of B . After the adjustment, securely tighten setscrews ① .

3-5. Adjustment of the pressure of the work clamp unit



WARNING :

Turn OFF the power before starting the work so as to prevent accidents caused by abrupt start of the sewing machine.

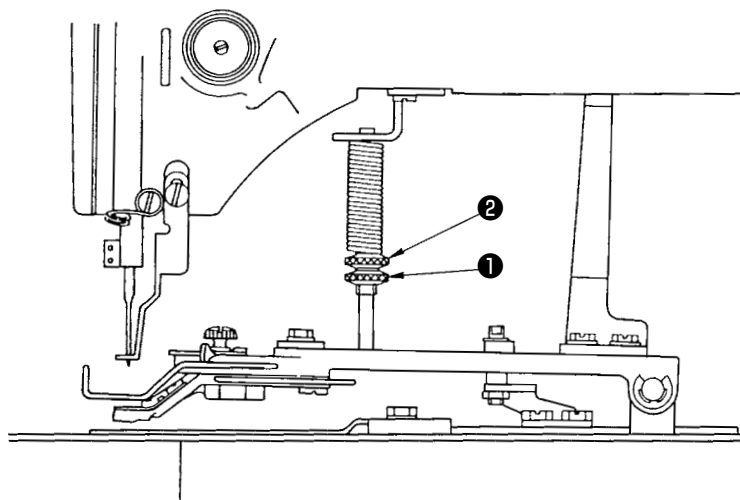

The pressure of the work clamp unit should be minimized as long as the material does not warp during sewing. Loosen adjusting screw ① and turn adjusting screw ② to obtain the aforementioned pressure.

3-6. Adjustment of the wiper spring



WARNING :

Turn OFF the power before starting the work so as to prevent accidents caused by abrupt start of the sewing machine.

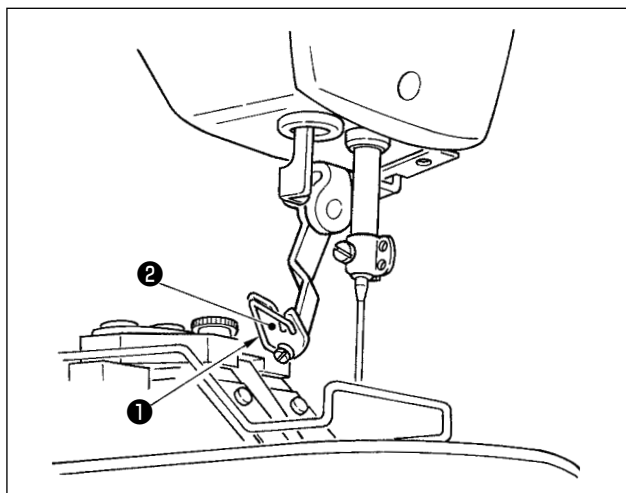

Wiper spring ① retains the needle thread after thread trimming in between wiper ② and the wiper spring. Correct properly the tension of wiper spring ① so that the tension at that time becomes 0.2 to 0.3N (a little higher tension than that of the bobbin thread coming out of the bobbin case).



If the retaining of the needle thread is excessive, the thread may protrude from the upper side of the button.

4. OTHERS

4-1. Installing the save button bar (accessory part)



WARNING :

Turn OFF the power before starting the work so as to prevent accidents caused by abrupt start of the sewing machine.

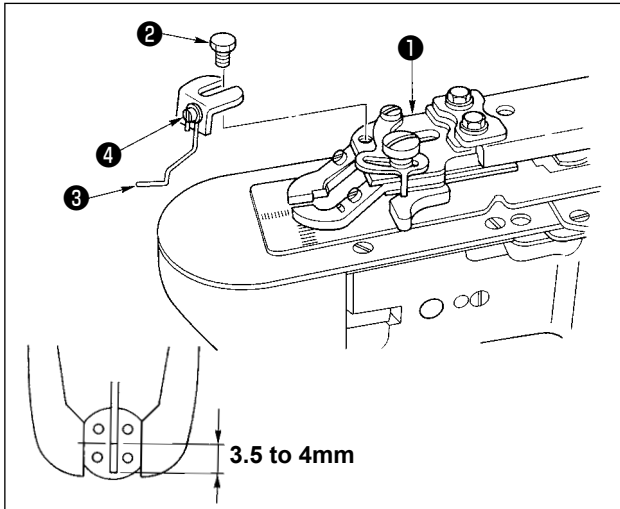

- 1) Install save button bar ③ on button clamp base ① with hexagon screw ② .
- 2) Adjust so that a clearance of 3.5 to 4 mm is provided between the center of the button and the top end of the save button bar.
- 3) To adjust the raising amount of the save button bar, loosen screw ④ , and move the save button bar up or down.

4-2. Model classification according to the button size

Model		LK-1903BN-301	LK-1903BN-302			
Button size classification		For small-sized buttons	For medium-sized button			
Outside diameter of applicable buttons (mm)		ø10 to ø20	ø10 to ø20			
Sewing size (mm)	Length	0 to 3.5	0 to 4.5			
	Width	0 to 3.5	0 to 4.5			
Button clamp jaw lever	Thickness (mm)	2.2 (2.7)	※	※		
	Part No.	Right	MAZ155070B0	B	MAZ156070B0	C
			(MAZ156070B0)	C	(MAZ155070B0)	B
	Left	MAZ155080B0	B	MAZ156080B0	C	
(MAZ156080B0)		C	(MAZ155080B0)	B		
Needle hole guide		MAZ15501000	MAZ15601000			
Feed plate		MAZ15502000	MAZ15602000			

The part in parentheses are those to be specially ordered.

※Engraved marker

4-3. Attaching the shank button (optional)

(1) Specifications

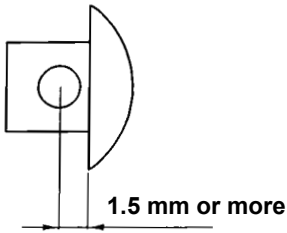
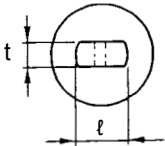
Model	Optional														
Needle	TQx3 #14														
Shape of button	Outside diameter	Max. $\phi 20$													
	Diameter of hole	Min. $\phi 1.5$													
	Position of hole														
Shape of shank section	 <table border="1" data-bbox="1059 775 1398 965"> <thead> <tr> <th rowspan="2">t</th> <th colspan="2">l(mm)</th> </tr> <tr> <th>Minimum</th> <th>Maximum</th> </tr> </thead> <tbody> <tr> <td>1</td> <td>4</td> <td>9</td> </tr> <tr> <td>3</td> <td>3</td> <td>8</td> </tr> <tr> <td>5</td> <td>-</td> <td>7</td> </tr> </tbody> </table> <p>As for the dimensions of the shape of shank section, refer to the above table for reference.</p>	t	l(mm)		Minimum	Maximum	1	4	9	3	3	8	5	-	7
t	l(mm)														
	Minimum	Maximum													
1	4	9													
3	3	8													
5	-	7													
Sewing speed	Max. speed of the pattern data is limited to 2,700 sti/min. However, set it to 1,500 sti/min for the shank button.														
Stitch shape	Sewing pattern program No.18 to No.22 (Refer to < Sewing program list > of "IV.2-3. Various sewing modes" p.85.)														

(2) Adjusting the height of the needle bar

WARNING :
 Turn OFF the power before starting the work so as to prevent accidents caused by abrupt start of the sewing machine.

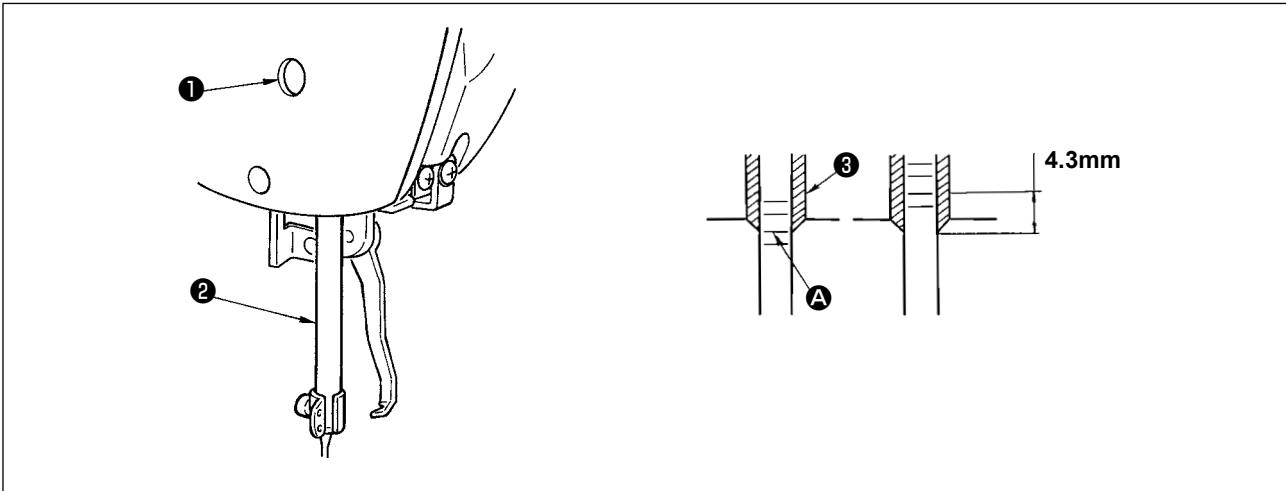

- 1) Loosen needle bar connection screw ① and move the needle bar ② up or down so that second engraved marker line A as counted from the bottom is aligned with the bottom end of needlebar bushing ③ when turning the hand pulley to bring the needle bar to its lowest position. Then further raise only the needle bar by 4.3mm, and tighten needle bar connection screw ① .
- 2) Attach the needle (TQx3 #14).

(3) Adjusting the feed plate base

WARNING :
 Turn OFF the power before starting the work so as to prevent accidents caused by abrupt start of the sewing machine.

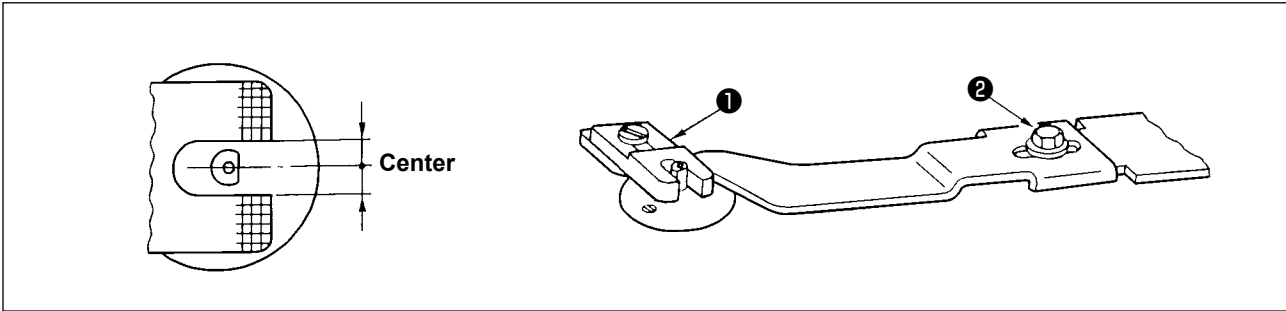

Adjust so that the slot of feed plate ① becomes the center of the boss section of the needle hole guide, and tighten setscrew ② .

Caution
 When the sewing state between the button and the material is loose, replace feed plate ① with the feed plate B to obtain a stronger sewing state. At this time, however, the outside diameter of the button is limited to max. $\varnothing 19$. So, be careful.

(4) Adjusting the button clamp support



WARNING :

Turn OFF the power before starting the work so as to prevent accidents caused by abrupt start of the sewing machine.

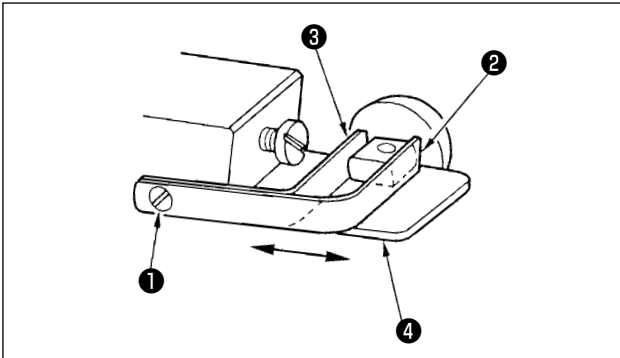

Loosen setscrew ①, and place the button to be used in between the button clamps. Then determine the longitudinal position of the button hole and the slot of button clamp base ④ by moving button clamp support, front ② and rear ③ back and forth. Then securely tighten the setscrew. At this time, if the clearance between button clamp support, front ② and rear ③ is a little smaller (approx. 0.5mm) than the outside diameter of the button to be placed, the button is securely clamped.

(5) Checking the needle entry point



WARNING :

Turn OFF the power before starting the work so as to prevent accidents caused by abrupt start of the sewing machine.

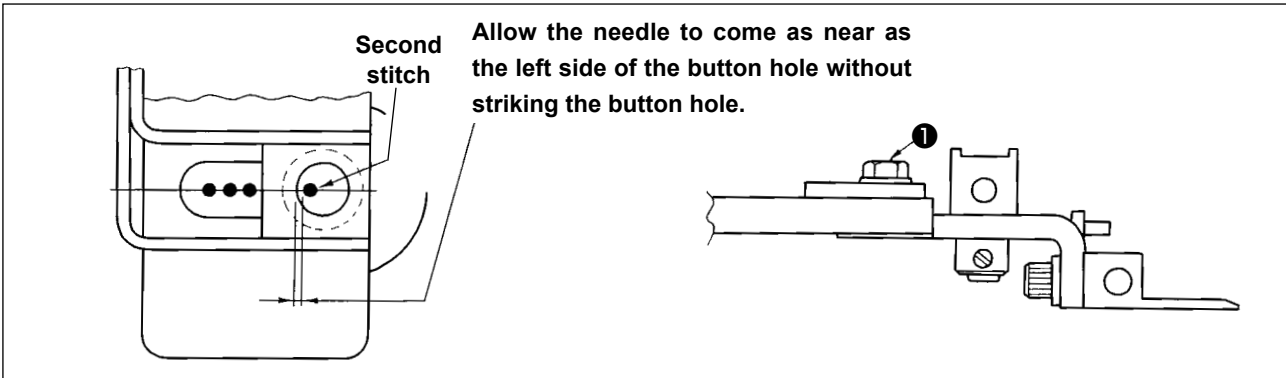

When checking the shape of the sewing pattern, fit the second stitch of the needle entry to the button hole, and tighten screw ①. (Refer to the item of checking the shape of the sewing pattern in the instruction manual for the LK-1900BN "I.5-4. Checking the contour of a sewing pattern" p.21.)

(6) Adjusting the button clamp base and the feed plate



WARNING :

Turn OFF the power before starting the work so as to prevent accidents caused by abrupt start of the sewing machine.

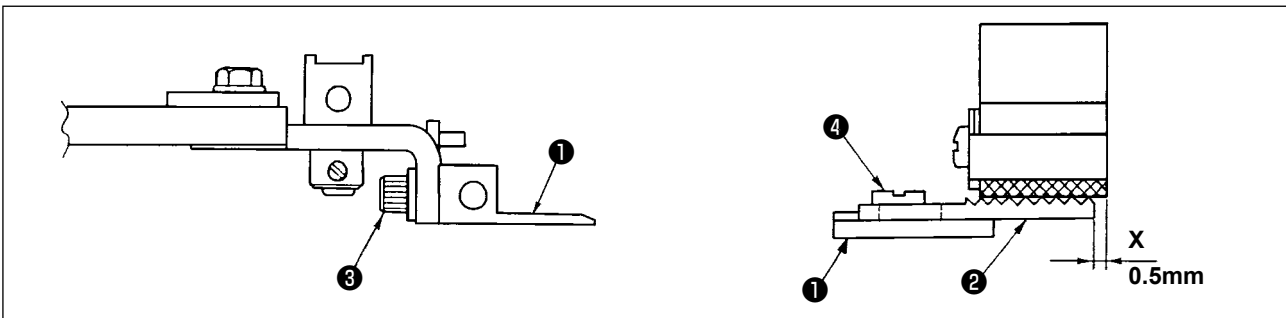

- 1) As for the attaching height of button clamp base ①, adjust the vertical position so that the bottom face of the button clamp base and the top face (knurl face) of feed plate A ② can equally press the material. Then tighten setscrew ③.
- 2) Adjust the position X (protrusion of the material), position of feed plate A ② against button clamp base ①, according to the thickness of the material using setscrew ④. The standard adjustment value is 0.5 mm.

(7) Adjusting the button support rubber



WARNING :

Turn OFF the power before starting the work so as to prevent accidents caused by abrupt start of the sewing machine.

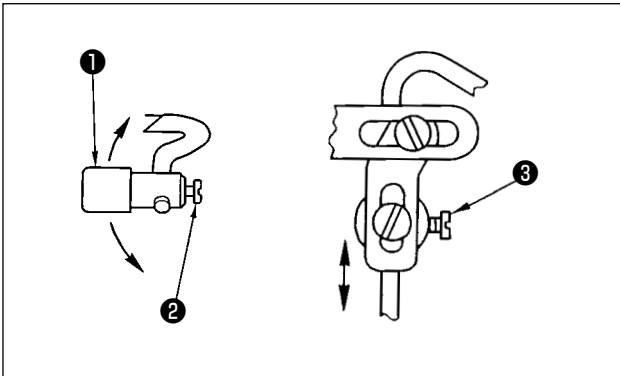

To adjust the position of button support rubber asm. ①, loosen setscrews ② and ③, and adjust so that the pressing section of the button support rubber can press the center of the button at right angles to the button. Then tighten the setscrews.

(8) Adjusting the button support link



WARNING :

Turn OFF the power before starting the work so as to prevent accidents caused by abrupt start of the sewing machine.

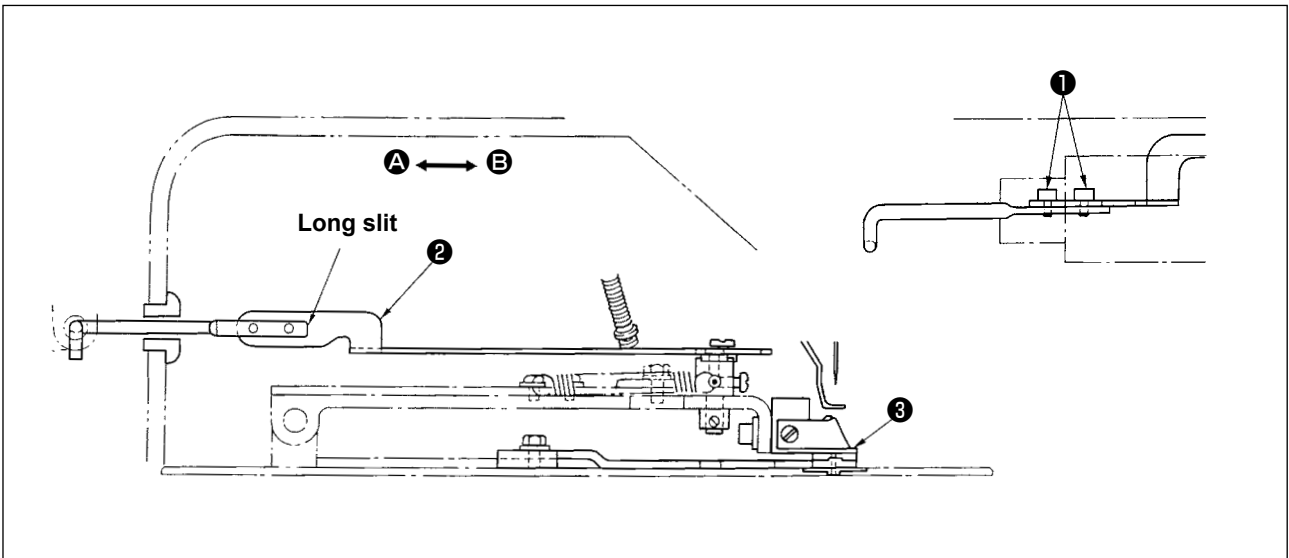

Loosen screw ①, and move button support link ② in the direction ① to make early the opening of the button support rubber when button clamp attaching base ③ goes up. Move it in the direction ② to retard the opening of the button support rubber. The standard adjustment is to adjust so that the button support rubber starts opening when button clamp attaching base ③ has gone up by 1 mm.

V. EXPLANATION OF THE LK-1903BBN HIGH-SPEED COMPUTER-CONTROLLED FLAT BUTTON SEWING MACHINE (WITH THE BIRD'S NEST PREVENTING AND SHORTER-THREAD REMAINING TYPE THREAD TRIMMER)

1. SPECIFICATIONS

Different specifications from those of the LK-1900BN only are described.

1	Max. sewing speed	2,700 sti/min
2	Thread	Polyester spun thread #60 - #80
3	Needle	DPx17 #11, #14
4	Lift of the work clamp foot	Max. 10mm
5	Number of standard patterns	34 patterns
6	Air pressure	0.5 MPa
7	Air consumption	18.7 dm ³ /min(ANR)

2. PREPARATION OF THE SEWING MACHINE

2-1. Installation of the sewing machine and preparation of the operation



DANGER :

Be sure to perform the work with two persons or more when moving the sewing machine.

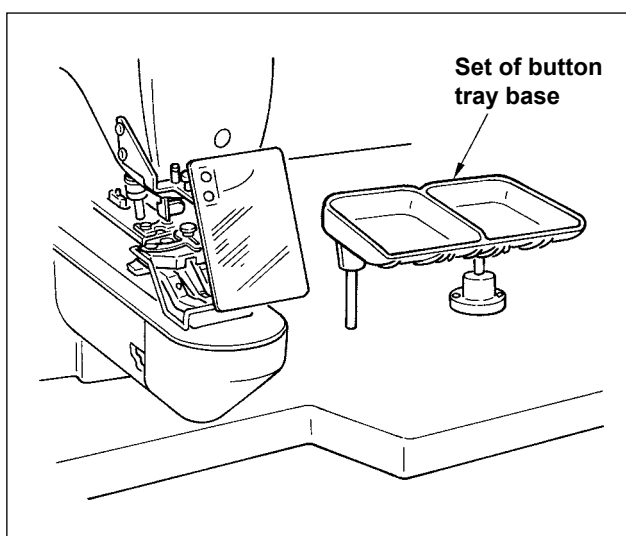

- 1) Installation of the sewing machine head and the control box is the same as that of the LK-1900BN. Refer to the instruction manual for the LK-1900BN.
- 2) Install a set of the button tray base to a convenient place for the work as the set is included in the accessories.
- 3) The way of operation is the same as that of the LK-1900BN.

2-2. Installing the regulator and solenoid valve asm.

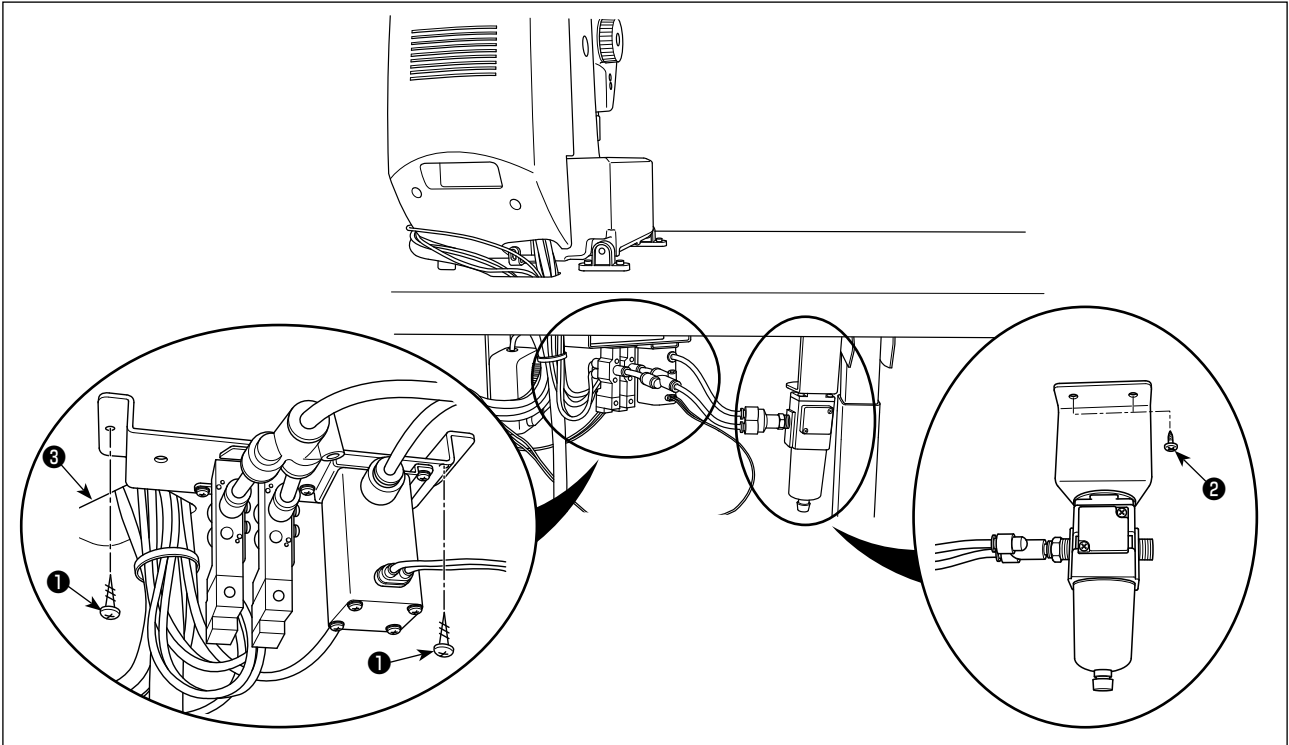

Mount the solenoid valve asm. and regulator asm. on the underside of the table respectively with two setscrews ① and two setscrews ② .

Mount the solenoid valve asm., near cord through-hole ③ (see the figure) in and regulator asm. on the far left section of the underside of the table as observed from the worker.

2-3. Connecting the air piping



WARNING :

Turn OFF the power before starting the work so as to prevent accidents caused by abrupt start of the sewing machine.

(1) Connecting the suction pipe

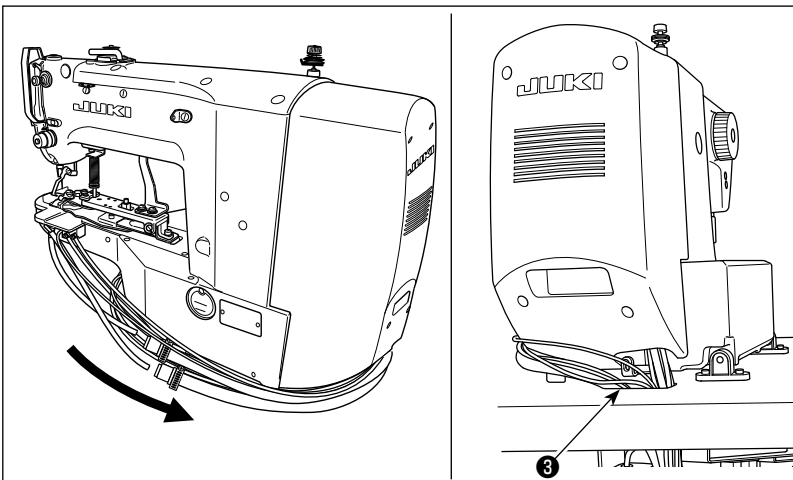

- 1) Pass the suction tube and air tube through hole ③ in the table from underside.

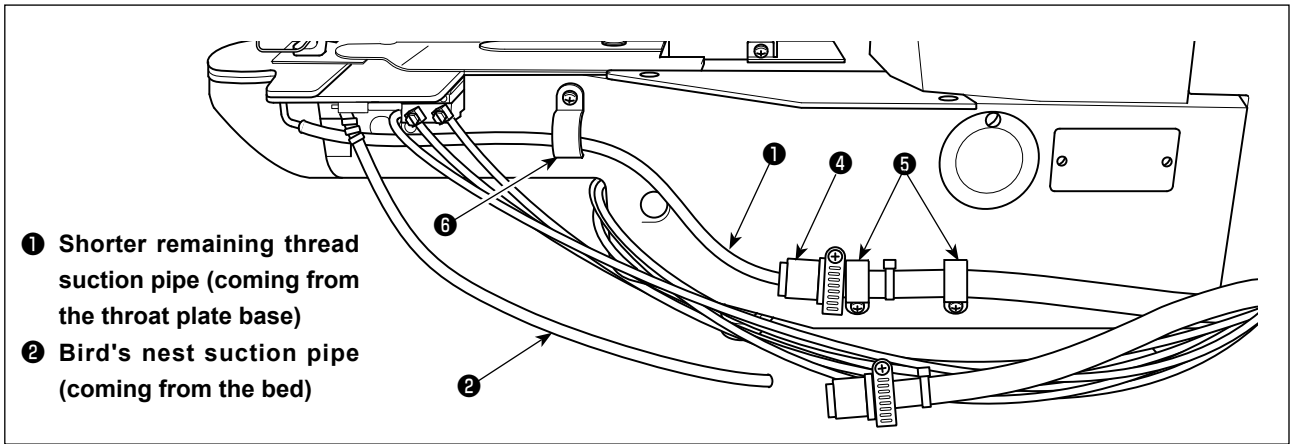

- ❶ Shorter remaining thread suction pipe (coming from the throat plate base)
- ❷ Bird's nest suction pipe (coming from the bed)

- 2) Connect shorter remaining thread suction pipe ❶ and suction tube asm. ❷ .
Fix suction tube asm. ❷ on the bed (at two locations) with cord clamp (small) ❸ .
- 3) Fix shorter remaining thread suction pipe ❶ at the cylinder section (one location) of bed with cord clamp (medium) ❹ .

Caution At this time, carefully prevent shorter remaining thread suction pipe ❶ from coming in contact with the moving section (including the cylinder rod). In addition, operate the sewing machine to check whether shorter remaining thread suction pipe ❶ moves smoothly without a hitch. If the pipe fails to move smoothly, re-check how it is fixed.

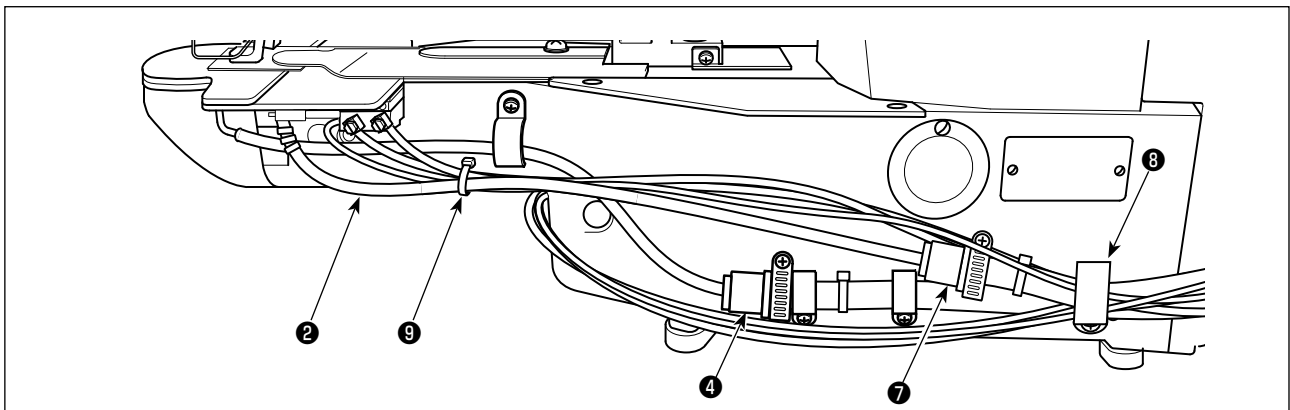

- 4) Connect bird's nest suction pipe ❷ and suction tube asm. ❸ .
Secure two suction tube asms. ❷ ❸ , and four air tubes and two sensor cords coming from the sewing machine head together on the bed with cord clamp (large) ❹ .
- 5) Bundle bird's nest suction pipe ❷ and two air tubes and one sensor cord coming from the sewing machine head together with cable clip ❺ .

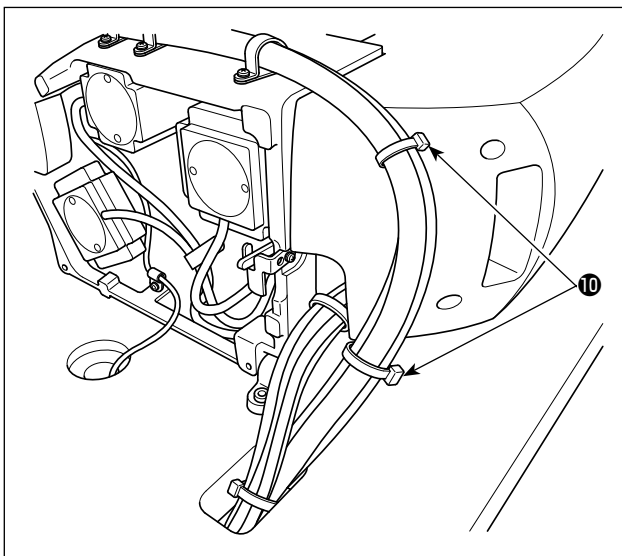

- 6) Secure the air tube and cylinder sensor cords with cable clip ❻ .

Caution Fix the air tube and cords so that they are neither crushed nor applied with unnecessary force when tilting the machine head.

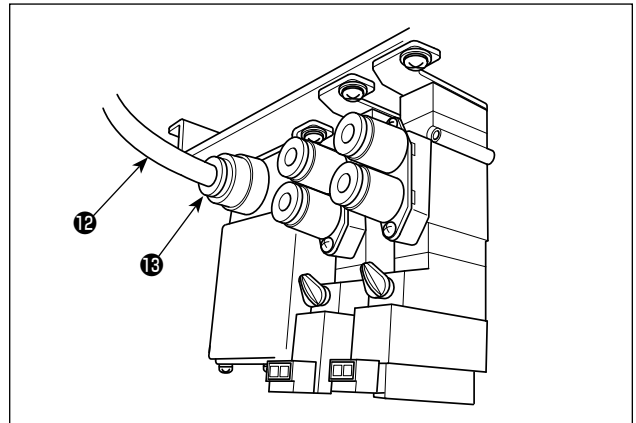
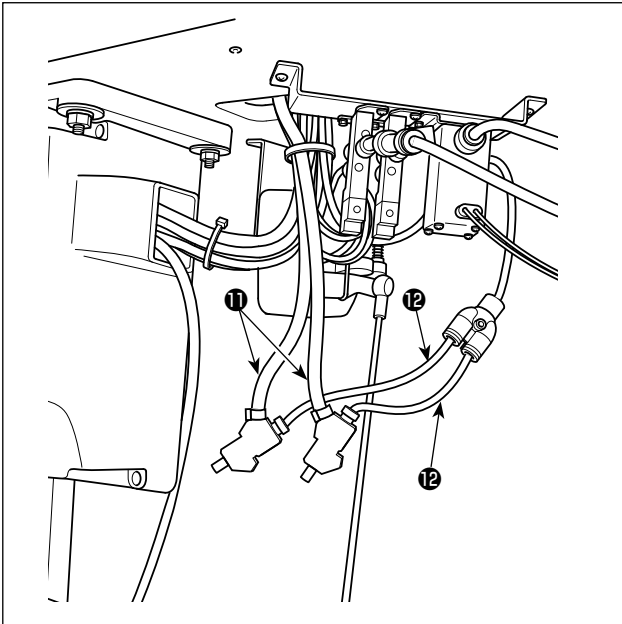

- 7) Connect shorter remaining thread suction pipe ① and suction tube asm. ② to which bird's nest suction pipe ② is connected respectively to air tube ⑫ .
- 8) Connect air tube ⑫ to solenoid valve ⑬ .

(2) Connecting the regulator and solenoid valve asm.

Connect coupling ① of the regulator and that of the solenoid valve asm. ⑤ with air tube asm. ② .
 Connect coupling ① of the regulator and solenoid valve ④ with air tube ø8 ③ .

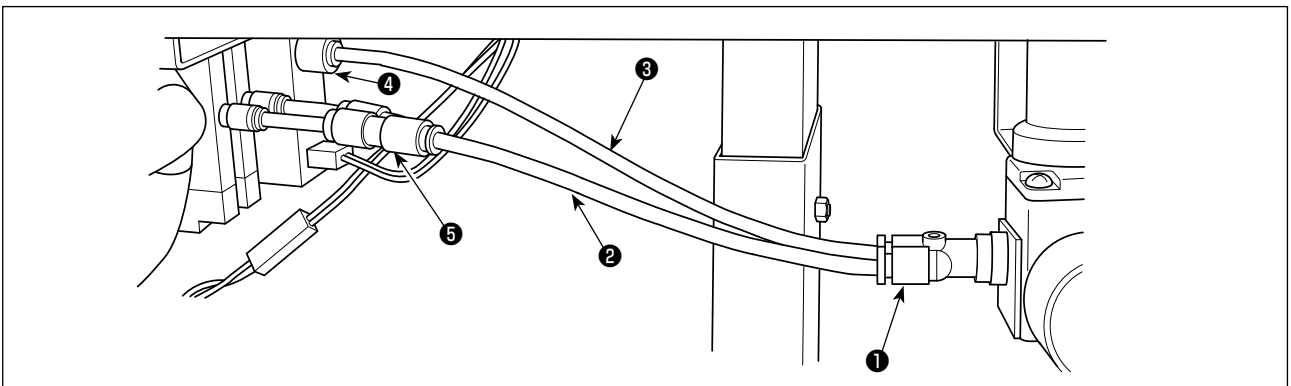

(3) Connecting the air tubes

Connect the air tubes coming from the sewing machine head to the solenoid valves matching the marked number on the tube with the valve number.

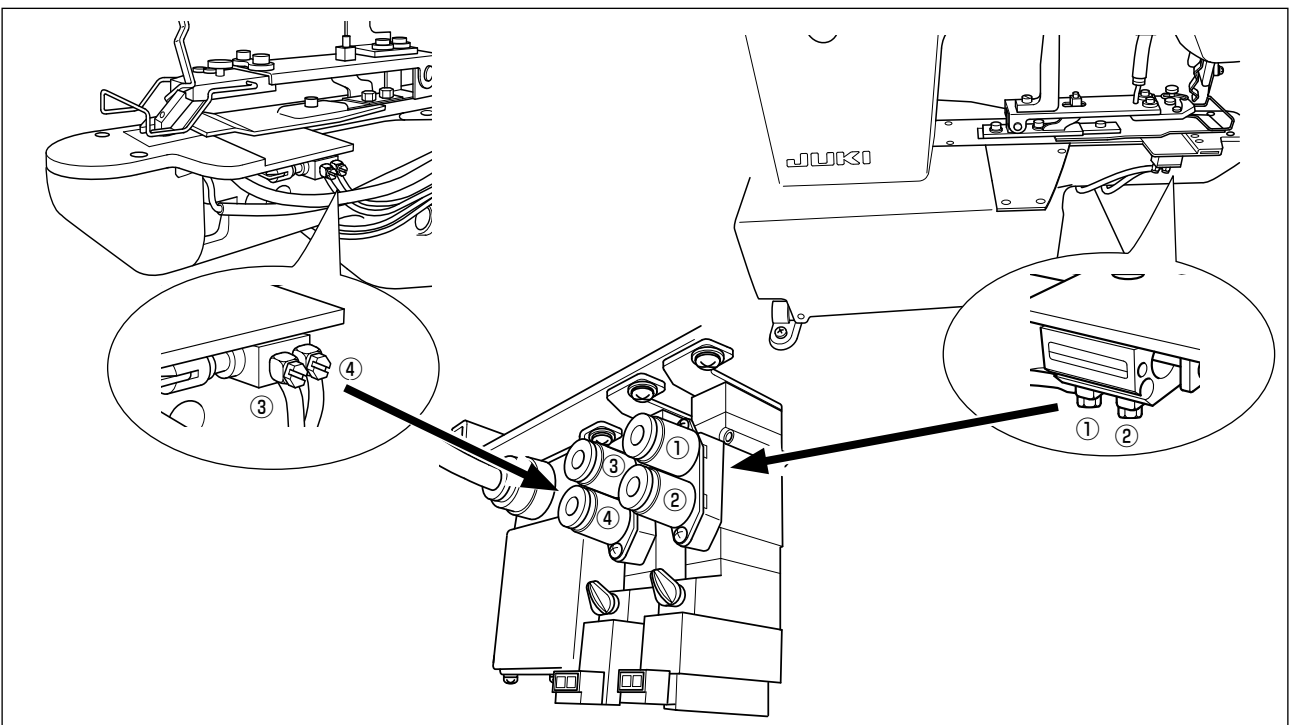

2-4. Connecting the cords



DANGER :

To prevent personal injuries caused by electric shock hazards or abrupt start of the sewing machine, carry out the work after turning OFF the power switch and a lapse of 5 minutes or more. To prevent accidents caused by unaccustomed work or electric shock, request the electric expert or engineer of our dealers when adjusting the electrical components.

For the sewing machine with the bird's nest preventing, shorter-thread remaining type thread trimmer, connect the cords listed below to the MAIN PCB.

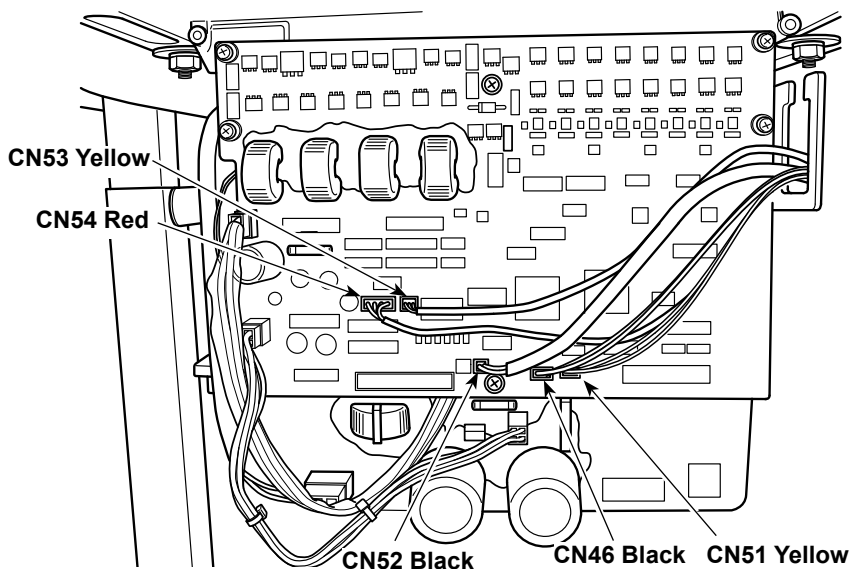
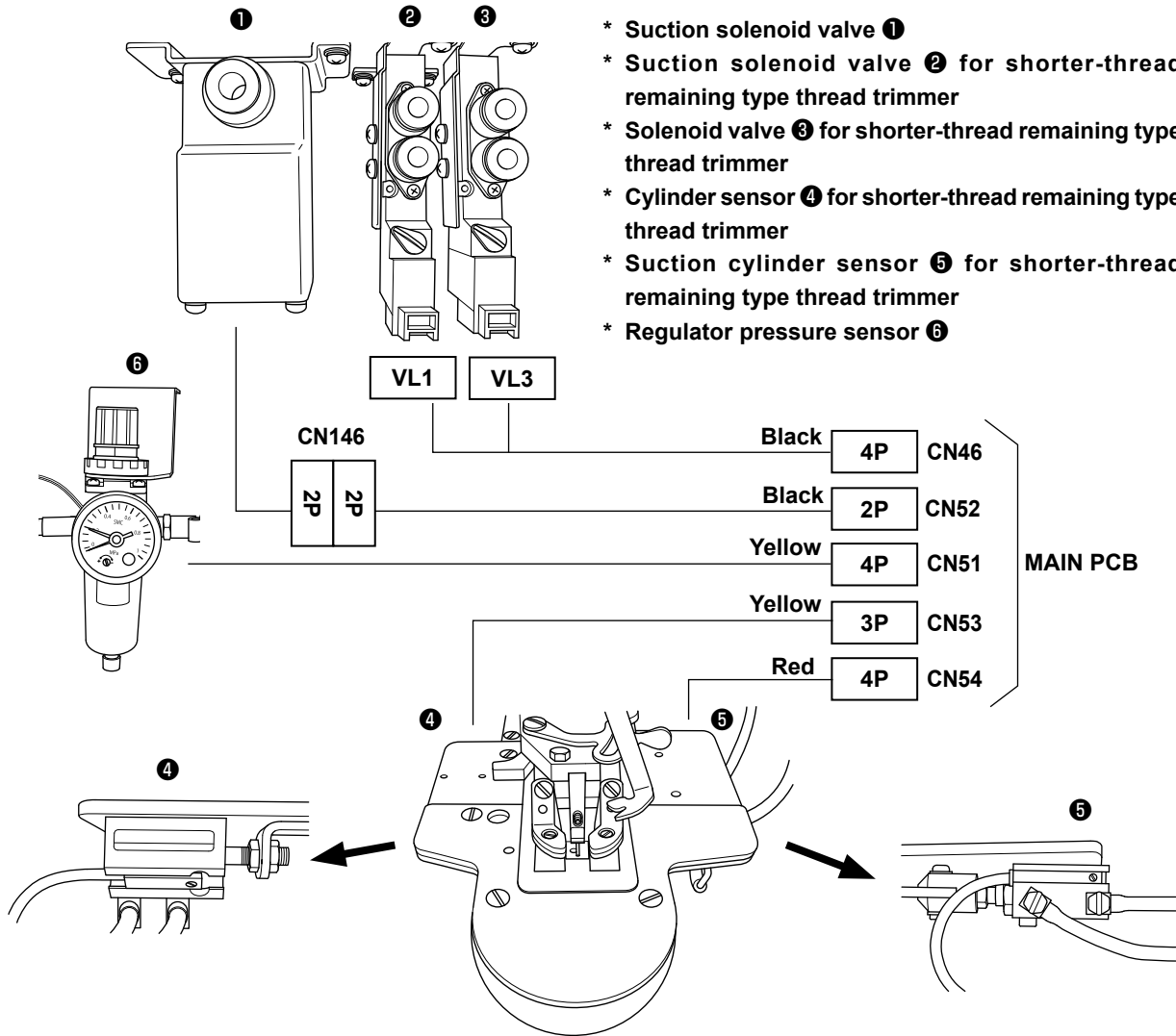

2-5. Installing the air hose

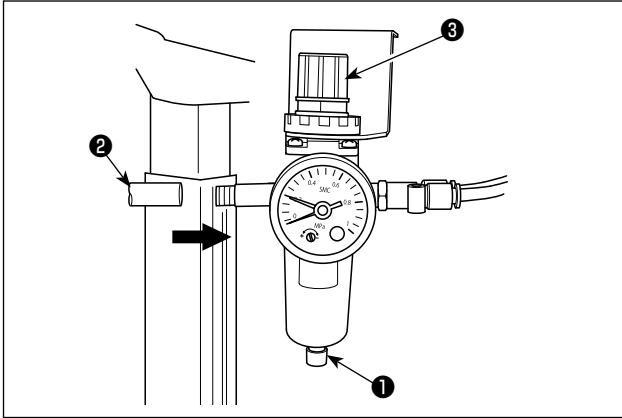

- * Air hose piping
Connect air hose ② to regulator ① .
- * Adjusting the pneumatic pressure
Pull up air regulating knob ③ of the regulator. Then, turn the knob to adjust the pneumatic pressure at 0.5 MPa. Push down the knob to its home position to fix it.
- * Adjusting the pressure sensor
The pressure sensor has been factory-set so that it detects when the air pressure drops below 0.3 MPa at the time of shipment. Do not change the setting of the pressure sensor.

2-6. Installing the cloth chip bag

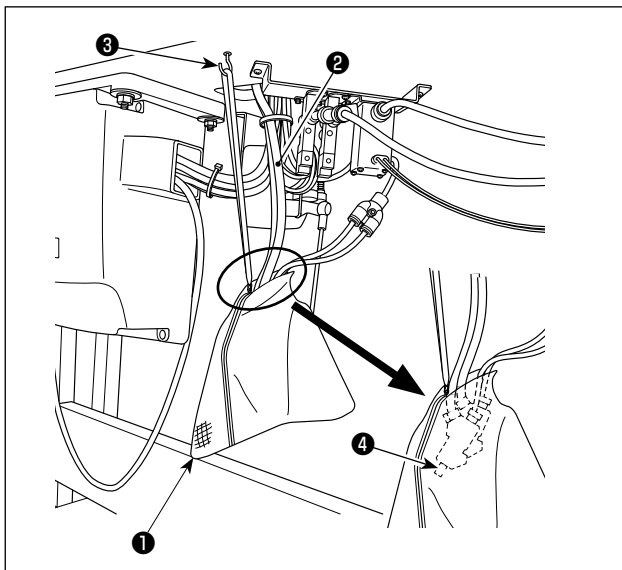

Put two suction pipes ② into cloth chip bag ① . Pass a string through the hole in zipper slider. Suspend the cloth chip bag from an easy-to-use location of the undersurface of the table with hanger ③ .

Attach cloth chip bag ① at a location where the air outlets ④ of the two suction pipes ② are brought to the upper section of the bag.



If the air outlet ④ of the pipe reaches the bottom of the cloth chip bag ① or is clogged with cloth chips, the suction force can be reduced.

2-7. Fixing the finger guard



DANGER :

Be sure to install the finger guard since it protects fingers from contact with the mechanical section.

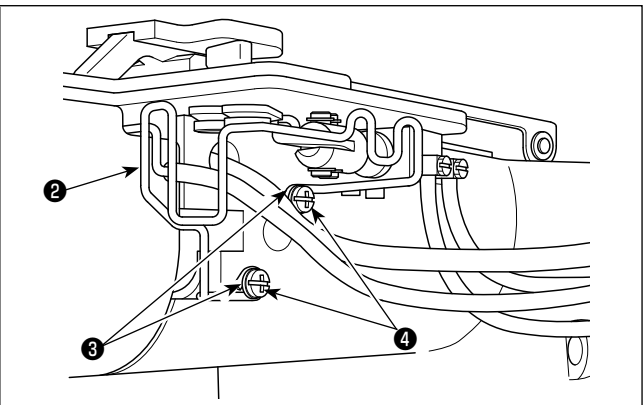
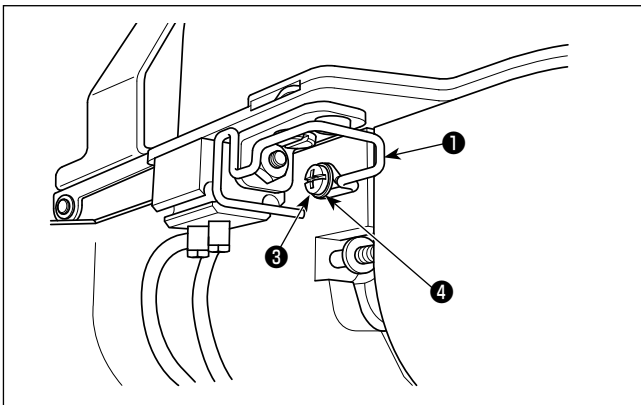

Install finger guard (left) ① and (right) ② on the machine head with screws ③ and washers ④ .



Install the finger guard, right ② while carefully preventing the air tubes to be caught under the guard to allow the shorter remaining thread suction pipe to operate smoothly. In the case the finger guards are mounted with excessively tilted, they can come in contact with the driving section, resulting in an error.

2-8. Needle and thread

Needle	Needle thread	Bobbin thread
DPx17 #11	# 80	# 80
DPx17 #14	# 60	# 80
	# 60	# 60























Needle and thread will vary in accordance with the sewing conditions. When using the needle and the thread, select them referring to the left table. Polyester spun thread are recommended.

2-9. Various sewing modes

(1) List of sewing patterns

Number of threads and standard sewing size of X and Y are as shown in the following list.

< Sewing program list >

Pattern No.	Stitch shape	Number of threads (thread)	Standard sewing size X (mm)	Standard sewing size Y (mm)	Pattern No.	Stitch shape	Number of threads (thread)	Standard sewing size X (mm)	Standard sewing size Y (mm)		
1 · 34		6-6	3.4	3.4	12 · 40		6-6	3.4	3.4		
2 · 35		8-8			13 · 41		8-8				
3		10-10			14		10-10				
4		12-12			15 · 42		6-6				
5 · 36		6-6			16 · 43		8-8				
6 · 37		8-8			17		10-10				
7		10-10			18 · 44		6			3.4	0
8		12-12			19 · 45		8				
9 · 38		6-6			20		10				
10 · 39		8-8			21		12				
11		10-10			22		16				

* The standard sewing sizes of X and Y are when the enlargement / reduction rate is 100%.
Use the pattern No. 34 to No.45 when the button hole is small (ø1.5 mm or less).

(2) Selection of the sewing pattern and the sewing width

- Selection of the sewing pattern is the same as that of the LK-1900BN.
- When the distance between holes of the button used does not fit the standard sewing width of the sewing pattern No., adjust the sewing width by enlarging/reducing the sewing width.
The way of enlarging/reducing is the same as that of the LK-1900BN. Refer to the table given below for the scale for enlargement/reduction in terms of the sewing width.
- After changing the sewing pattern No. and the sewing width, make sure of the needle entry point.
As for the way of confirmation, refer to the "1.5-4. Checking the contour of a sewing pattern"p.21 in the instruction manual for the LK-1900BN.

◎ Table of XY scale in terms of the sewing width

X•Y (mm)	2.4	2.6	2.8	3.0	3.2	3.4	3.6	4.0	4.3	4.5	4.7	5.2	5.6	6.0	6.2	6.4
%	71	76	82	88	94	100	106	118	126	132	138	153	165	176	182	188

3. ADJUSTMENT OF THE SEWING MACHINE

WARNING :
 Turn OFF the power before starting the work so as to prevent accidents caused by abrupt start of the sewing machine.

3-1. Adjusting the knife for the shorter thread remaining thread trimmer

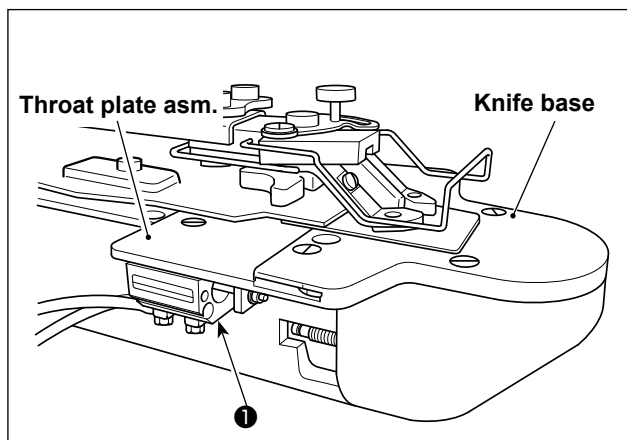

When the compressed air is supplied, shorter-thread remaining thread trimmer cylinder ① moves forward. This is the initial position.

Caution
 In the case cylinder ① does not move forward when the compressed air is supplied, the piping connection is not correct. Be aware mechanical failures such as needle breakage can occur, if sewing is carried out without correcting the connection of piping.

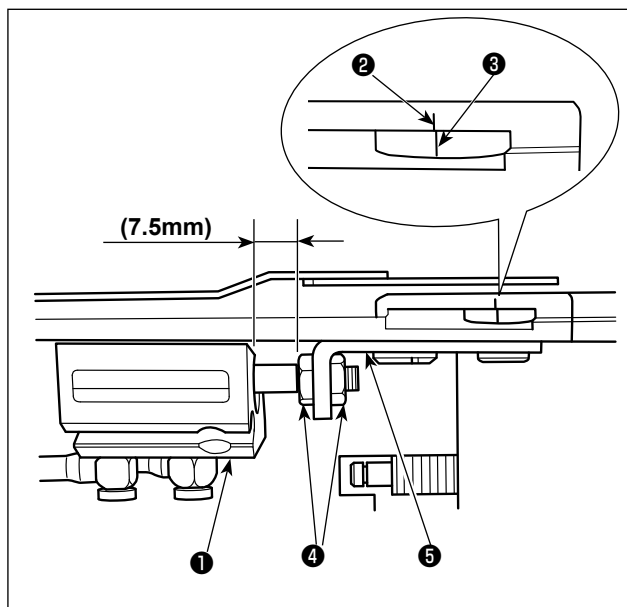

At the aforementioned initial position, loosen the nut ④ and adjust the cylinder guide ⑤ so that the notch mark ② in the knife base is aligned with the notch mark ③ on the moving knife base.

3-2. Adjusting the suction pipe for the shorter-thread remaining type thread trimmer

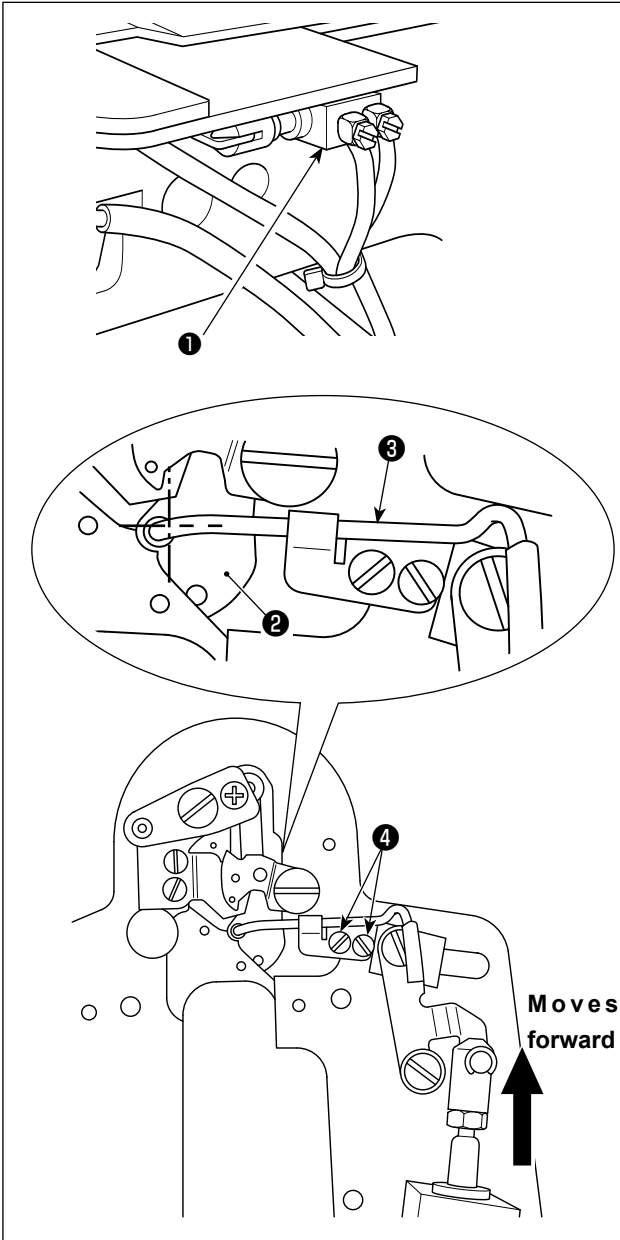

When the compressed air is supplied, suction cylinder ① for shorter-thread remaining type thread trimmer moves backward. This is the initial position.



Unless cylinder ① is in its recessed position when the pneumatic air is supplied, the piping connection is wrong. Be aware that mechanical failures such as needle breakage can occur, if sewing is continued in this state.

Loosen screw ④ and adjust so that the center of needle hole guide ② is aligned with the center of hole in suction pipe ③ when cylinder ① reaches its forward end.

3-3. Replacing the knife of the shorter-thread remaining thread trimmer

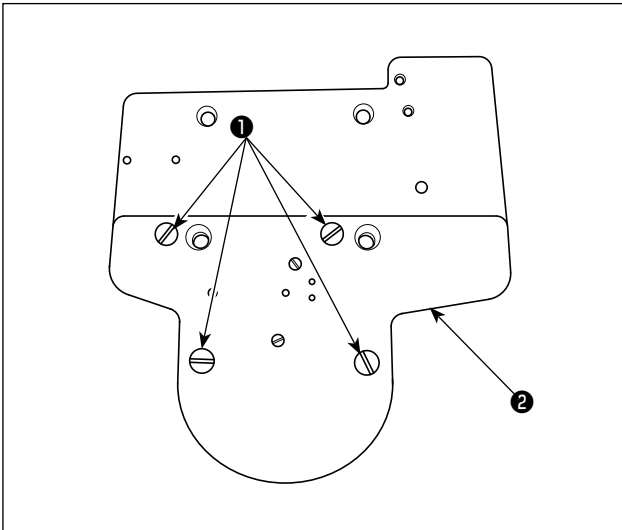

- 1) Remove screws **1** at four locations. Then, knife base **2** can be removed.

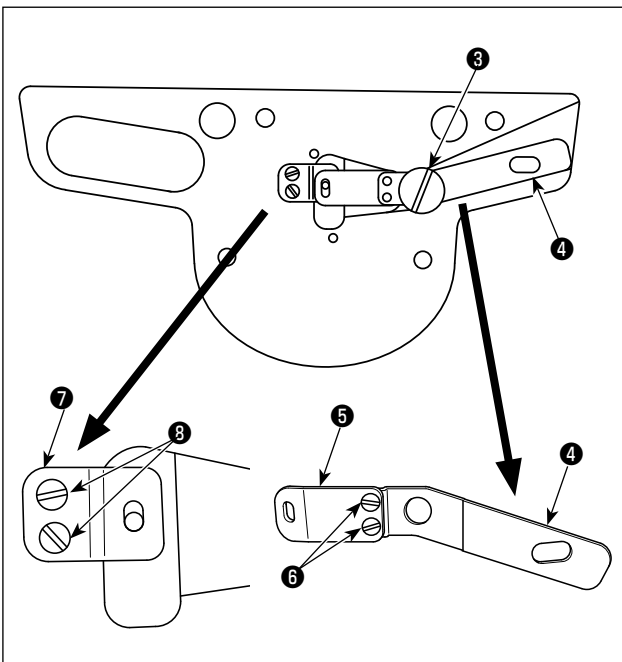

- 2) Moving knife support plate **4** and moving knife **5** removed in the joined state by removing hinge screw **3**. Remove two moving knife fixing screws **6** from the joined parts. Change moving knife **5** with a new one. In addition, remove two setscrews **7** and change counter knife **7** with a new one.

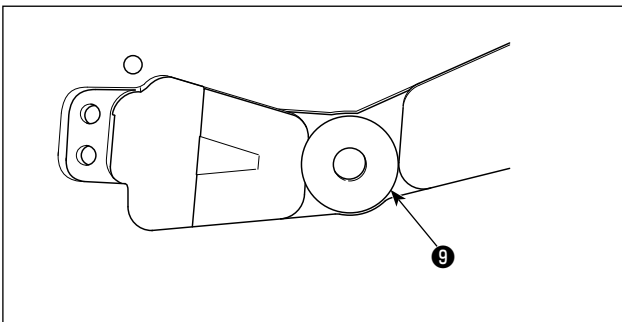

- 3) Place washer **9** (thickness: select one from 0.3 to 0.7 mm) between moving knife support plate **4** and knife base **2** to adjust the knife pressure.

3-4. Adjusting the work clamp rod (For 1903BBNS only)

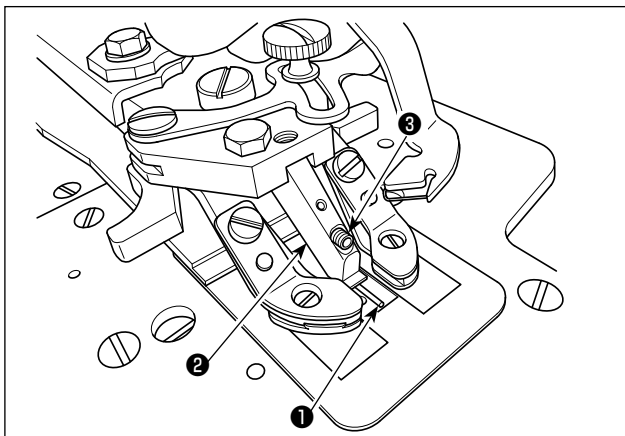

Fit work clamp rod ① in the slit in button guide foot ② . Fix the work clamp rod with setscrew ③ while pushing the rod upward.

The correct position of work clamp rod ① is as shown below.

Lateral position: The longitudinal center is aligned with the center of the button.

Vertical position: The undersurface of the work clamp rod is in parallel with the undersurface of button guide foot ② .

To adjust, check to be sure that work clamp rod ① is positioned as described above.

Be aware that loose stitches can be caused if work clamp rod ① is deformed or is positioned excessively low. Place the clamp rod at the correct position.

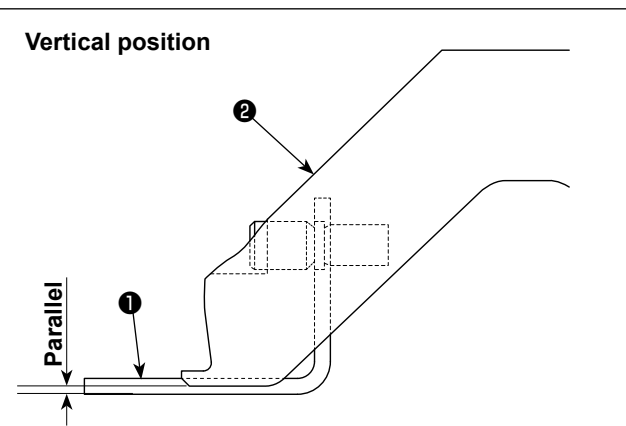
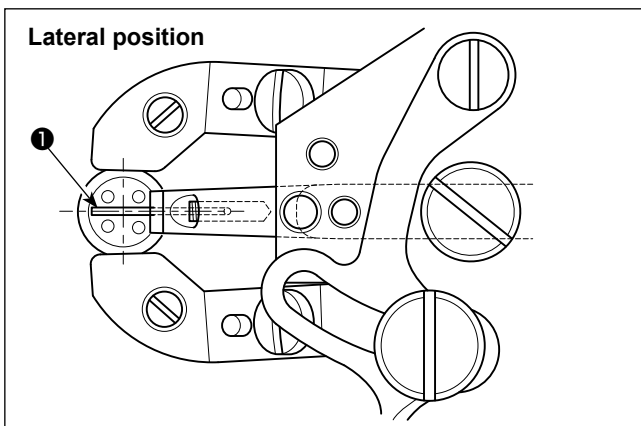

3-5. Replacing the non-slip sheet (For 1903BBNS only)

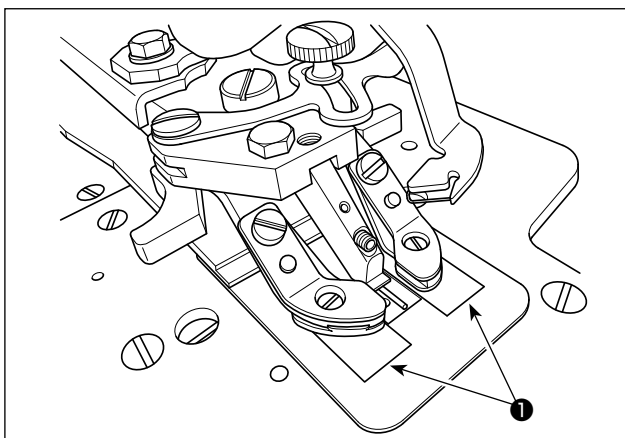

Non-slip unwoven cloths ① can become dirty. In such a case, cut the non-slip sheet supplied with the unit as an accessory into the size as shown in the figure and stick it after removing the dirty cloths.

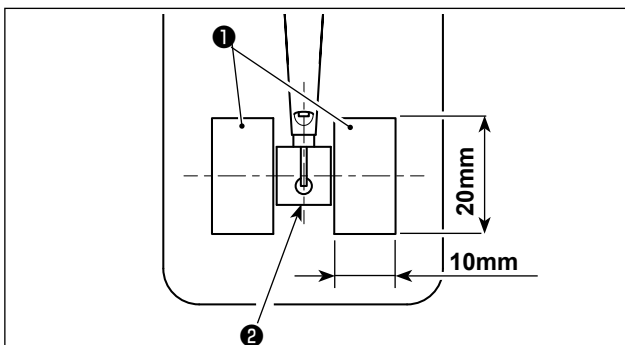

Stick the sheet (20 mm in length and 10 mm in width) so that its longitudinal center of the sheet is flush with the center of feed plate ② .

4. MAINTENANCE

4-1. Cleaning the inside of the hook cover

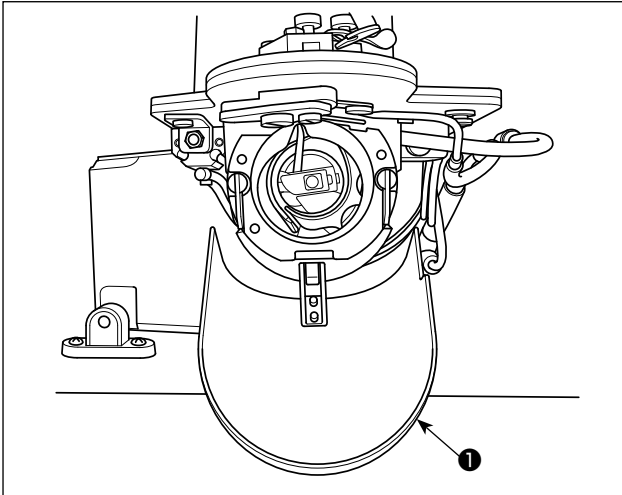

Periodically clean the inside of the hook cover ❶ to remove dust and thread waste.

4-2. Cleaning the thread clamp

When thread is caught at top end ❶ of the thread clamp, thread clamp becomes incomplete and sewing trouble at the sewing start will be caused. If sewing problems such as stitch skipping occur at the beginning of sewing, the below-stated cleaning should be carried out.

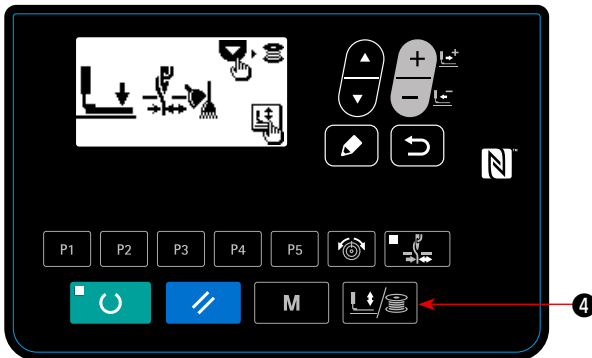

- 1) Press work PRESSER and WINDER key  ❷ to display "work clamp lowering screen".

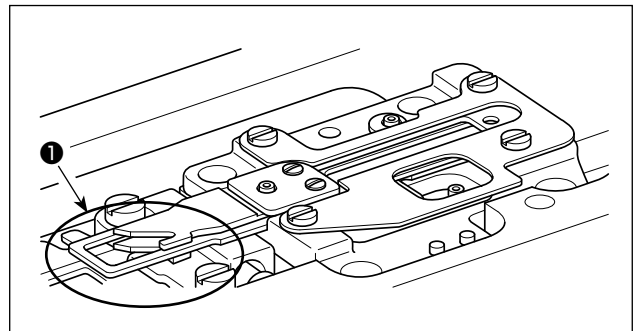

- 2) Open the hook cover. Blow cloth dust and thread waste off of the thread clamp by blowing air through the clearance between the throat plate base and the hook with an air gun or the like. Cloth dust is likely to gather in the circled section in the figure. Carefully blow cloth dust off of that section, in particular.

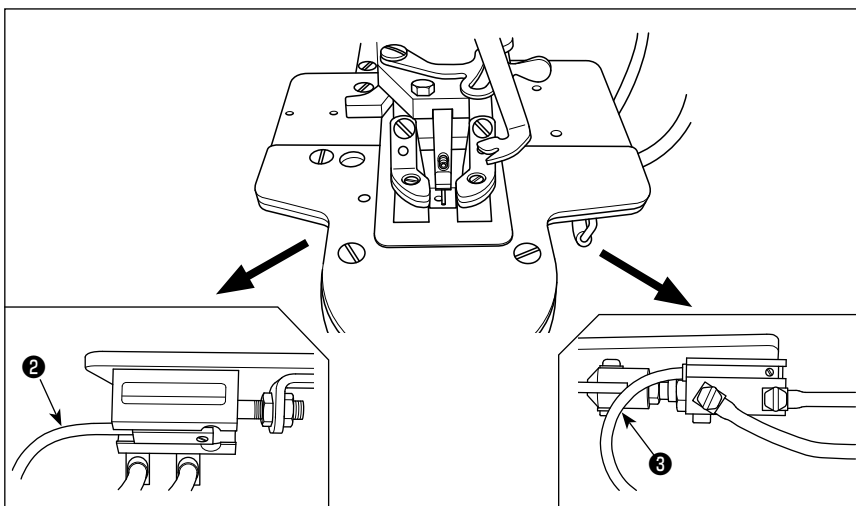

Caution
In the case of cleaning the inside of the hook with the throat plate base removed, take care not to stress right and left cylinder sensor cords ❷ and ❸.

VI. EXPLANATION OF THE LK-1900BBN COMPUTER-CONTROLLED, HIGH-SPEED BARTACKING MACHINE (WITH THE BIRD'S NEST PREVENTING AND SHORTER-THREAD REMAINING TYPE THREAD TRIMMER)

This chapter only describes the items which are different from the LK-1903BBNS.
All other items are same with the LK-1903BBNS.

1. SPECIFICATIONS

Different specifications from those of the LK-1900BN only are described.

1	Max. sewing speed	3,200 sti/min
2	Thread	Polyester spun thread #60 - #80
3	Needle	DPx17 #11, #14
4	Lift of the work clamp foot	Max. 10mm
5	Number of standard patterns	50 patterns
6	Air pressure	0.5 MPa
7	Air consumption	15.7 dm ³ /min(ANR)

2. PREPARATION OF THE SEWING MACHINE

2-1. Table of the sewing patterns

	No.	Stitch diagram	Number of stitches	Sewing size (mm)		(Note 2) No. of work clamp foot	
				Length-wise	Cross-wise		
Large size bartacking	1		42	2.0	16	1	
						2	
						3	
		2		42	2.0	10	1
			2				
			3				
		3 ※		42	2.5	16	1
			4				
		4 ※		42	3.0	24	6
			7				
	5		28	2.0	10	1	
						2	
						3	
	6 ※		28	2.5	16	1	
						4	
	7		36	2.0	10	1	
						2	
						3	
	8 ※		36	2.5	16	1	
						4	
	9 ※		56	3.0	24	6	
						7	
	10 ※		64	3.0	24	6	
						7	
Small size bartacking	11		21	2.5	6	8	
	12		28	2.5	6		
	13		36	2.5	6		
Knit goods bartacking	14		14	2.0	8	5	
	15		21	2.0	8		
	16		28	2.0	8		
Straight line bartacking	17		21	0	10	1	
						2	
						3	
		18		28	0	10	1
			2				
			3				
		19		28	0	25	6
			7				
		20		36	0	25	6
			7				
	21		41	0	25	6	
		7					
	22		44	0	35	(Note3)	
Lengthwise bartacking	23		28	20	4.0	9	
						10	
	24		36	20	4.0	9	
						10	
	25		42	20	4.0	9	
						10	
26		56	20	4.0	9		
					10		
Lengthwise straight line bartacking	27		18	20	0	11	
	28		21	10	0		
29		21	20	0			
30		28	20	0			

- (Note) 1. Sewing size shows the dimensions when the scale rate is 100%.
 2. Refer the No. of work clamp foot to the separate table of work clamp foot.
 3. For No. 22, process the work clamp foot blank for use.
 4. Use the patterns with ※ marks for sewing denim.

	No.	Stitch diagram	Number of stitches	Sewing size (mm)		(Note 2) No. of work clamp foot
				Length-wise	Cross-wise	
Semilunar bartacking	31		52	7	10	13
	32		63	7	12	13
	33		24	6	10	13
	34		31	6	12	13
	35		48	10	7	14
	36		48	10	7	14
Large size bartacking	37		90	3	24	6
						7
Knit goods bartacking	38		28	2	8	5
Round bartacking	39		28	ø12		16
	40		48			

	No.	Stitch diagram	Number of stitches	Sewing size (mm)		(Note 2) No. of work clamp foot	
				Length-wise	Cross-wise		
Lengthwise bartacking	41		29	20	2.5	12	
	42		39	25	2.5	12	
	43		45	25	2.5	12	
	44		58	30	2.5	12	
	45		75	30	2.5	12	
	46		42	30	2.5	12	
	Radial tacking	47		91	ø8		15
		48		99			
		49		148			
		50		164			



1. Pattern Nos. 41 to 46 are for the optional work clamp foot No. 12. The origin of the patterns is different by 5 mm up and down from that of lengthwise bartacking pattern Nos. 23 to 26.
2. In the case of linear bartacking, round bartacking and semilunar bartacking, the excess amount of needle thread is approximately same as that of the LK-1900BN.

3. ADJUSTMENT OF THE SEWING MACHINE



WARNING :

Turn OFF the power before starting the work so as to prevent accidents caused by abrupt start of the sewing machine.

3-1. Replacing the bird's nest preventing knife

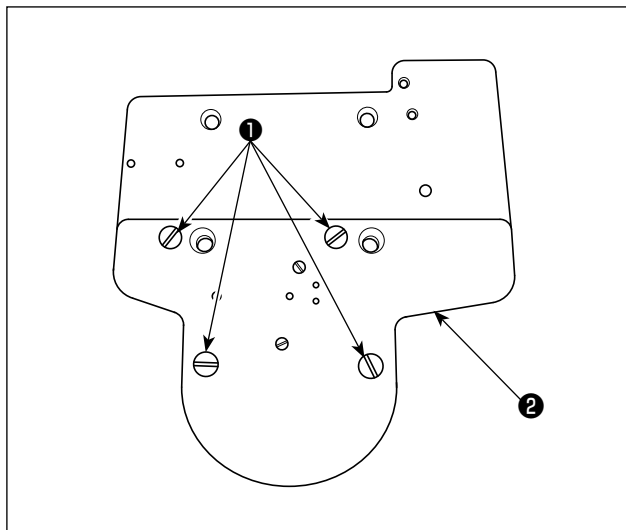

- 1) Remove screws ❶ at four locations. Then, knife base ❷ can be removed.

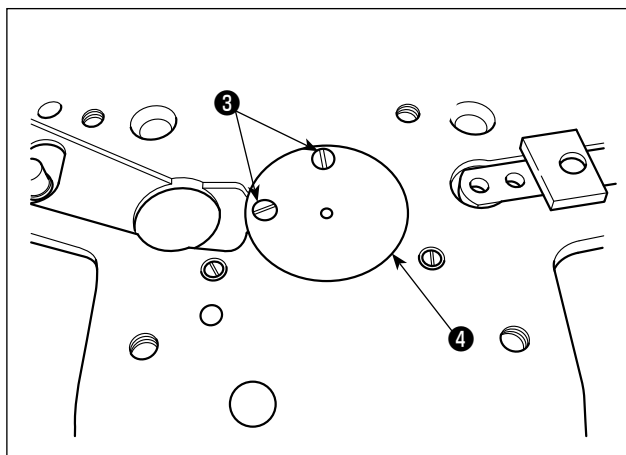

- 2) Remove two screws ❸ . Remove needle hole guide ❹ .

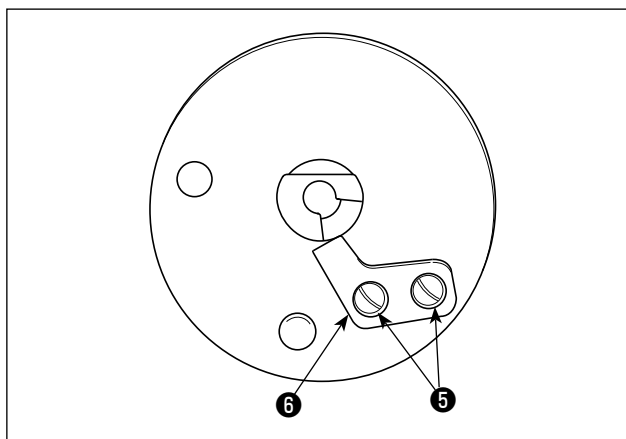

- 3) When you remove two screws ❺ , bird's nest preventing knife ❻ will come off.
Replace the knife with a new one. Then, attach the needle hole guide and knife base back to their positions.

VII. DRAWING OF THE TABLE

Longitudinal installation type table (Part No. 40143093)

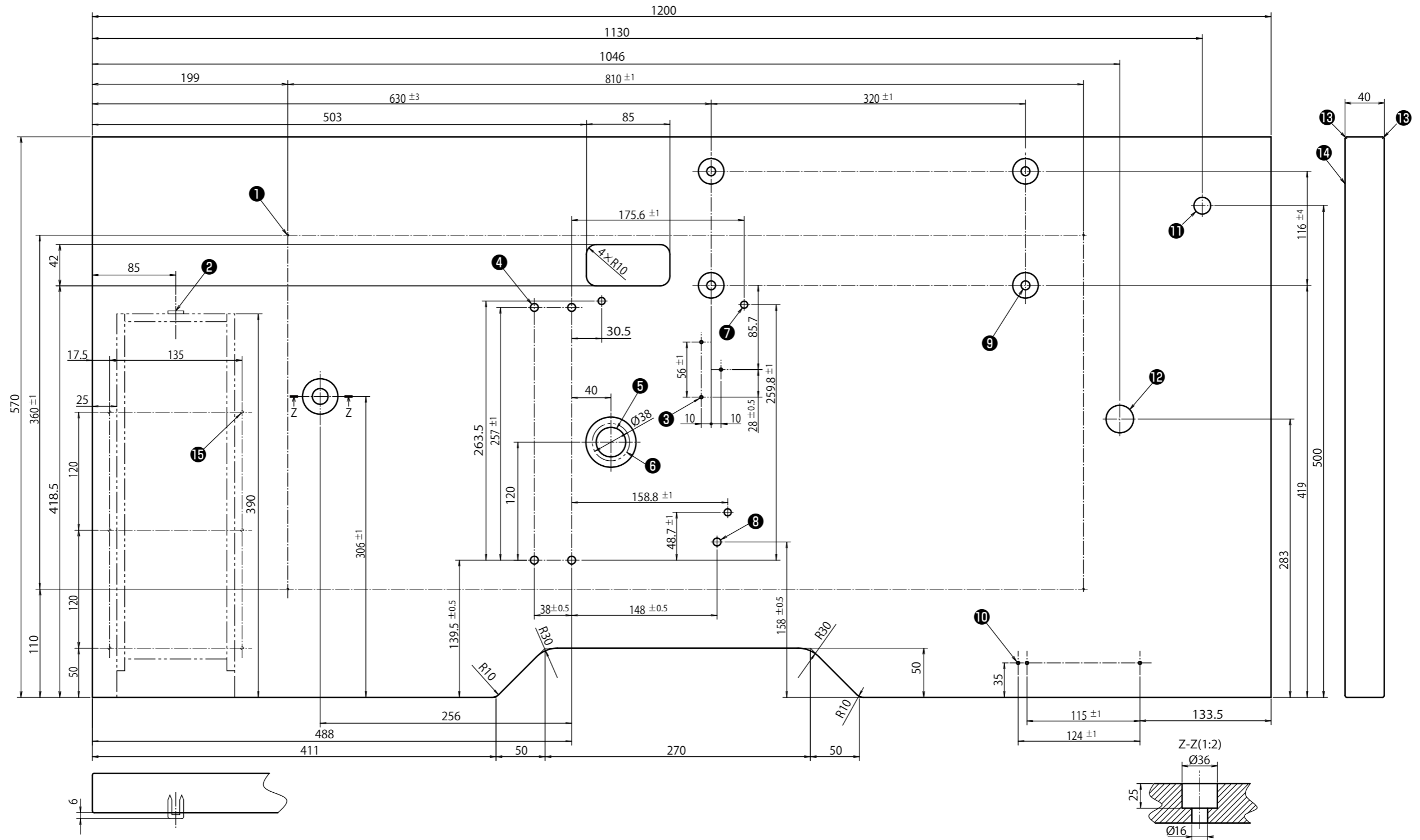

- ① 4- drilled hole 2, 10 deep on the rear side (stand installing hole)
- ② Drawer stopper installing position (one place on the rear side)
- ③ 3- drilled hole 3, 10 deep on the rear side (pedal installing hole)
- ④ 4- drilled hole 8
- ⑤ Drilled hole 30, 51 spot face 16 deep
- ⑥ Oil drain funnel installing hole
- ⑦ 3- drilled hole 7, 6 deep
- ⑧ Drilled hole 8
- ⑨ 4-drilled hole 9, 26 spot face 1 deep

- ⑩ 3-drilled hole 3, 10 deep on the rear side (power switch installing hole)
- ⑪ Drilled hole 17
- ⑫ Drilled hole 28
- ⑬ R2 (all corners)
- ⑭ Right side
- ⑮ 6- drilled hole 3, 10 deep on the rear side (drawer installing hole)

Lateral installation type table

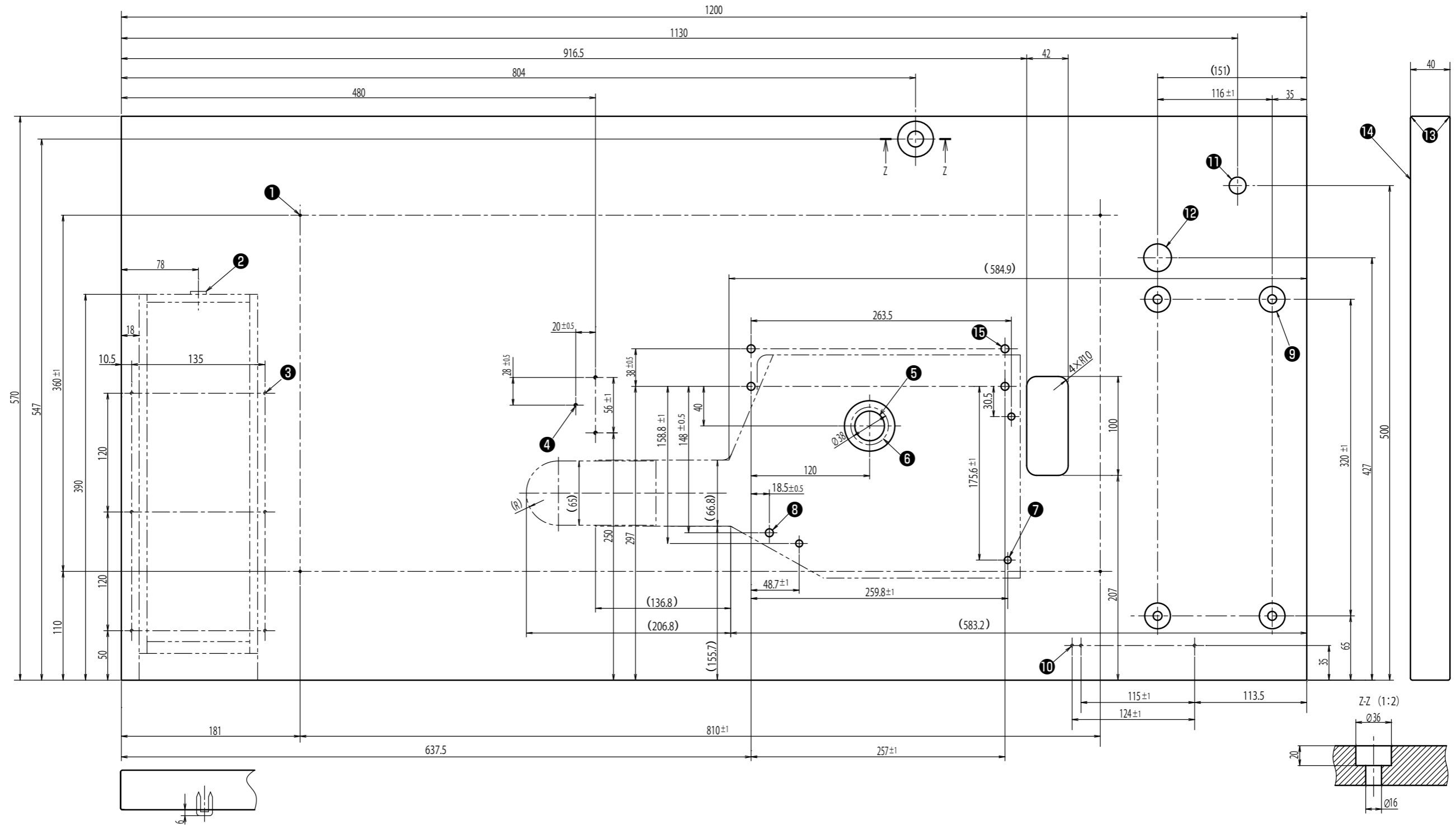

- ① 4- drilled hole 2, 10 deep on the rear side (stand installing hole)
- ② Drawer stopper installing position (one place on the rear side)
- ③ 6- drilled hole 3, 10 deep on the rear side (drawer installing hole)
- ④ 3- drilled hole 3, 10 deep on the rear side (pedal installing hole)
- ⑤ Drilled hole 30, 51 spot face 16 deep
- ⑥ Oil drain funnel installing hole
- ⑦ 3- drilled hole 7, 6 deep
- ⑧ Drilled hole 8

- ⑨ 4-drilled hole 9, 26 spot face 7 deep
- ⑩ 3-drilled hole 3, 10 deep on the rear side (power switch installing hole)
- ⑪ Drilled hole 17
- ⑫ Drilled hole 28
- ⑬ R2 (all corners)
- ⑭ Right side
- ⑮ 4- drilled hole 8