





AMS-210E / IP-410  
AMS-210E / CP-20

Instruction  
manual

# CONTENTS

<b>I . MECHANICAL SECTION (WITH REGARD TO THE SEWING MACHINE).....</b>	<b>1</b>
1. SPECIFICATIONS .....	1
2. CONFIGURATION .....	2
3. INSTALLATION .....	3
3-1. Installing the electrical box .....	3
3-2. Installing and connecting the power switch.....	3
3-3. Installation of the sewing machine head .....	4
3-4. Installing the drain receiver and the head support rubber .....	5
3-5. Safety switch .....	5
3-6. Installing the throat plate auxiliary cover .....	6
3-7. Installing the panel.....	8
3-8. Attaching the pedal chain (For S specification only) .....	8
3-9. Installing the thread stand .....	8
3-10. Raising the machine head.....	9
3-11. Connecting the cord .....	10
3-12. Installing the motor cover .....	12
3-13. Managing the cord .....	13
3-14. Connecting the pneumatic components (Pneumatic type only) .....	13
3-15. Installing the air hose (Pneumatic type only).....	16
3-16. Installing the eye protection cover .....	16
4. PREPARATION OF THE SEWING MACHINE .....	17
4-1. Lubrication.....	17
4-2. Attaching the needle.....	18
4-3. Threading the machine head .....	18
4-4. Installing and removing the bobbin case .....	19
4-5. Installing the bobbin .....	19
4-6. Adjusting the thread tension .....	20
4-7. Intermediate presser height.....	21
4-8. Adjusting the thread take-up spring .....	22
5. OPERATION OF THE SEWING MACHINE.....	22
5-1. Sewing.....	22
5-2. Needle thread clamp device.....	23
<b>II . OPERATION SECTION (WITH REGARD TO THE PANEL).....</b>	<b>25</b>
1. PREFACE .....	25
2. WHEN USING IP-410 .....	28
2-1. Name of each section of IP-410 .....	28
2-2. Buttons to be used in common .....	29
2-3. Basic operation of IP-410 .....	30
2-4. LCD display section at the time of sewing shape selection .....	32
(1) Sewing shape data input screen.....	32
(2) Sewing screen .....	34
2-5. Performing sewing shape selection.....	36
2-6. Changing item data.....	38
2-7. Checking pattern shape .....	40
2-8. Performing modification of needle entry point .....	41

(1) Changing the thread tension value .....	41
(2) Changing the intermediate presser height value .....	42
<b>2-9. How to use temporary stop .....</b>	<b>43</b>
(1) To continue performing sewing from some point in sewing .....	43
(2) To perform re-sewing from the start .....	44
<b>2-10. When setting of sewing product is difficult because of interruption of needle tip .....</b>	<b>45</b>
<b>2-11. Winding bobbin thread .....</b>	<b>46</b>
(1) When performing winding bobbin thread while performing sewing .....	46
(2) When performing winding bobbin thread only .....	46
<b>2-12. Using counter .....</b>	<b>47</b>
(1) Setting procedure of the counter .....	47
(2) Count-up releasing procedure .....	49
(3) How to change the counter value during sewing .....	49
<b>2-13. Performing new register of users' pattern.....</b>	<b>50</b>
<b>2-14. Naming users' pattern .....</b>	<b>51</b>
<b>2-15. Performing new register of pattern button .....</b>	<b>52</b>
<b>2-16. LCD display section at the time of pattern button selection .....</b>	<b>53</b>
(1) Pattern button data input screen.....	53
(2) Sewing screen .....	55
<b>2-17. Performing pattern button No. selection .....</b>	<b>57</b>
(1) Selection from the data input screen .....	57
(2) Selection by means of the shortcut button.....	58
<b>2-18. Changing contents of pattern button.....</b>	<b>59</b>
<b>2-19. Copying pattern button .....</b>	<b>60</b>
<b>2-20. Changing sewing mode.....</b>	<b>61</b>
<b>2-21. LCD display section at the time of combination sewing.....</b>	<b>62</b>
(1) Pattern input screen.....	62
(2) Sewing screen .....	64
<b>2-22. Performing combination sewing .....</b>	<b>66</b>
(1) Selection of combination data.....	66
(2) Creating procedure of the combination data.....	67
(3) Deleting procedure of the combination data .....	68
(4) Deleting procedure of the step of the combination data .....	68
<b>2-23. Changing memory switch data.....</b>	<b>69</b>
<b>2-24. Using information .....</b>	<b>70</b>
(1) Observing the maintenance and inspection information .....	70
(2) Releasing procedure of the warning .....	72
(3) Observing the production control information .....	72
(4) Performing setting of the production control information .....	74
(5) Observing the working measurement information .....	76
<b>2-25. Using communication function .....</b>	<b>78</b>
(1) Handling possible data .....	78
(2) Performing communication by using the media.....	79
(3) Performing communication by using RS-232C.....	79
(4) Take-in of the data .....	80
(5) Taking in plural data together.....	81
<b>2-26. Performing formatting of the media .....</b>	<b>83</b>
<b>3. WHEN USING CP-20.....</b>	<b>84</b>
<b>3-1. Name of each section of CP-20.....</b>	<b>84</b>
<b>3-2. Operation of CP-20 (Basic).....</b>	<b>85</b>

(1) Item data setting .....	85
(2) Checking the contour of a sewing pattern .....	87
(3) Performing modification of the needle entry point .....	88
(4) When the pattern is changed .....	90
<b>3-3. Performing copying of pattern.....</b>	<b>90</b>
<b>3-4. Performing deletion of pattern.....</b>	<b>91</b>
<b>3-5. Sewing.....</b>	<b>92</b>
(1) Change to the other sewing pattern.....	92
<b>3-6. Winding bobbin .....</b>	<b>93</b>
(1) To wind a bobbin while the sewing machine is performing sewing .....	93
(2) To wind a bobbin independently .....	93
<b>3-7. Operation of CP-20 (Advanced).....</b>	<b>94</b>
(1) Performing sewing using the pattern keys (  ,  ,  ,  and  ).....	94
(2) Register to the pattern key.....	94
(3) Sewing operation .....	96
<b>3-8. Performing sewing using the combination function .....</b>	<b>97</b>
(1) Register of the combination .....	97
(2) Sewing operation .....	98
<b>3-9. When using as "bobbin thread counter" .....</b>	<b>99</b>
(1) How to use the temporary stop.....	99
<b>3-10. Start and change of the memory switch.....</b>	<b>100</b>
<b>3-11. Correspondence table of LED and 7-segment display.....</b>	<b>101</b>
<b>4. MEMORY SWITCH DATA LIST .....</b>	<b>104</b>
4-1. Data list .....	104
4-2. Initial value list .....	110
<b>5. ERROR CODE LIST .....</b>	<b>112</b>
<b>6. MESSAGE LIST .....</b>	<b>118</b>
<b>III. MAINTENANCE OF SAWING MACHINE .....</b>	<b>121</b>
<b>1. MAINTENANCE.....</b>	<b>121</b>
1-1. Adjusting the height of the needle bar (Changing the length of the needle) .....	121
1-2. Adjusting the needle-to-shuttle relation .....	121
1-3. Adjusting the height of the feeding frame .....	123
1-4. Adjusting the vertical stroke of the intermediate presser.....	123
1-5. The moving knife and counter knife.....	124
1-6. Needle thread clamp device.....	124
1-7. Thread breakage detector plate .....	125
1-8. Draining waste oil .....	125
1-9. Amount of oil supplied to the hook.....	126
1-10. Replacing the fuse .....	126
1-11. Changing the voltage of 100 $\longleftrightarrow$ 200V.....	127
1-12. Replenishing the designated places with grease .....	128
1-13. Troubles and corrective measures (Sewing conditions).....	131
<b>2. OPTIONAL.....</b>	<b>133</b>
2-1. Table of Needle hole guide.....	133
2-2. Silicon oil tank .....	133

# I. MECHANICAL SECTION (WITH REGARD TO THE SEWING MACHINE)

## 1. SPECIFICATIONS

1	Sewing area	X (lateral) direction	Y (longitudinal) direction
		AMS-210E-1306	: 130 mm × 60 mm
		AMS-210E-1510	: 150 mm × 100 mm
		AMS-210E-2206	: 220 mm × 60 mm
		AMS-210E-2210	: 220 mm × 100 mm
2	Max. sewing speed	2,700 rpm (When sewing pitch is 3 mm or less)	
3	Stitch length	0.1 to 12.7 mm (Min. resolution : 0.05 mm)	
4	Feed motion of feeding frame	Intermittent feed (2-shaft drive by stepping motor)	
5	Needle bar stroke	41.2 mm	
6	Needle	DP x 5, DP x 17	
7	Lift of feeding frame	Max. 25mm (Pneumatic type only Max.30mm)	
8	Intermediate presser stroke	4 mm (Standard) (0 to 10 mm)	
9	Lift of intermediate presser	20 mm	
10	Intermediate presser DOWN position variable	Standard 0 to 3.5 mm (Max. 0 to 7.0 mm)	
11	Shuttle	Double-capacity semi-rotary hook	
12	Lubricating oil	New Defrix Oil No. 2 (Supplied by oiler)	
13	Memory of pattern data	EEPROM , Media • EEPROM : Max. 200 patterns (Max. 20,000 stitches/pattern) • Media : Max. 999 patterns (Max. 50,000 stitches/pattern)	
14	Temporary stop facility	Used to stop machine operation during a stitching cycle.	
15	Enlarging / Reducing facility	Allows a pattern to be enlarged or reduced on the X axis and Y axis independently when sewing a pattern. Scale : 1% to 400% times (0.1% steps)	
16	Enlarging / Reducing method	Pattern enlargement / reduction can be done by increasing / decreasing either stitch length or the number of stitches. (Only increase/decrease of stitch length when pattern button is selected and CP-20 is used)	
17	Max. sewing speed limitation	200 to 2,700 rpm (Scale : 100 rpm steps)	
18	Pattern selection facility	Pattern No. selection method (EEPROM : 1 to 200, Media : 1 to 999) (CP-20 is the scroll type.)	
19	Bobbin thread counter	UP/DOWN method (0 to 9,999)	
20	Sewing counter	UP/DOWN method (0 to 9,999) (IP-410 only)	
21	Memory back-up	In case of a power interruption, the pattern being used will automatically be stored in memory.	
22	2nd origin setting facility	Using jog keys, a 2nd origin (needle position after a sewing cycle) can be set in the desired position within the sewing area. The set 2nd origin is also stored in memory. (IP-410 only)	
23	Sewing machine motor	Servo-motor	
24	Dimensions	1,200mm (W) x 710mm (L) x 1,200mm (H) (Excluding thread stand)	
25	Mass (gross mass)	Machine head 69kg, control box 16.5kg	
26	Power consumption	500 VA	
27	Operating temperature range	5°C to 35°C	
28	Operating humidity range	35 % to 85 % (No dew condensation)	
29	Line voltage	Rated voltage ±10% 50 / 60 Hz	
30	Air pressure used	Standard 0.35 to 0.4 MPa (Max. 0.55 MPa)(Pneumatic type only)	
31	Air consumption	1.8 dm <sup>3</sup> / min (ANR) (Pneumatic type only)	
32	Needle highest position stop facility	After the completion of sewing, the needle can be brought up to its highest position.	
33	Noise	Workplace-related noise at sewing speed n = 2,700 min <sup>-1</sup> : L <sub>PA</sub> ≤ 84dB(A) Noise measurement according to DIN 45635-48-B-2-KL2	

## 2. CONFIGURATION

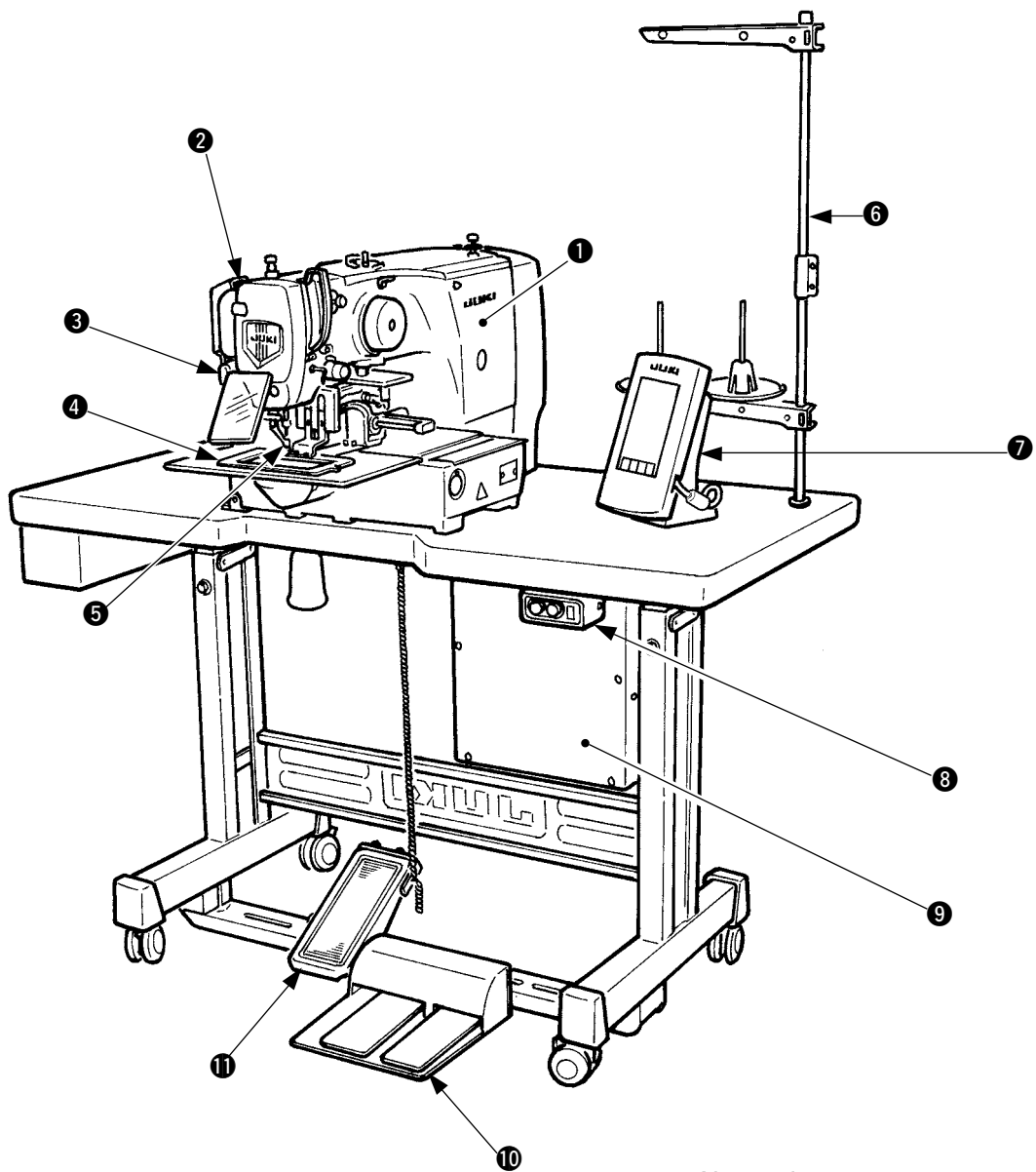

- ① Machine head
- ② Wiper switch
- ③ Temporary stop switch
- ④ Feeding frame
- ⑤ Intermediate presser
- ⑥ Thread stand
- ⑦ Operation panel (IP-410 or CP-20)
- ⑧ Power switch
- ⑨ Control box
- ⑩ Foot pedal
- ⑪ Manual pedal (Excluding pneumatic type)

Air regulator  
(for pneumatic type only)

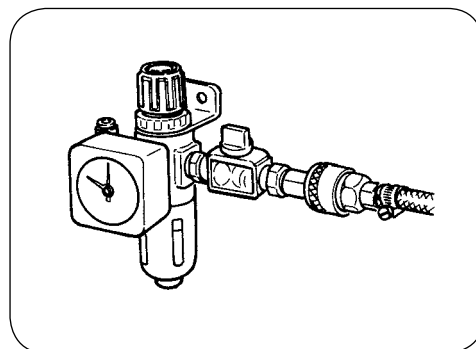

## 3. INSTALLATION

### 3-1. Installing the electrical box

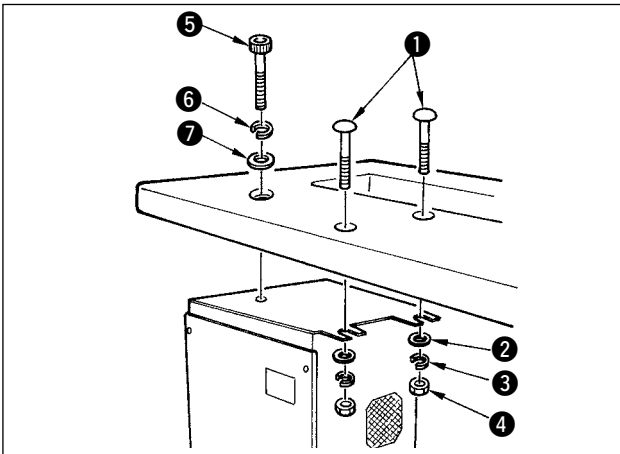

Install the electrical box on the underside of the table at the location illustrated using round-head bolt **1**, plain washer **2**, spring washer **3** and nut **4** supplied with the machine, and using bolt having hexagonal indentation on the head **5** spring washer **6** and plain washer **7** supplied with the machine.

### 3-2. Installing and connecting the power switch

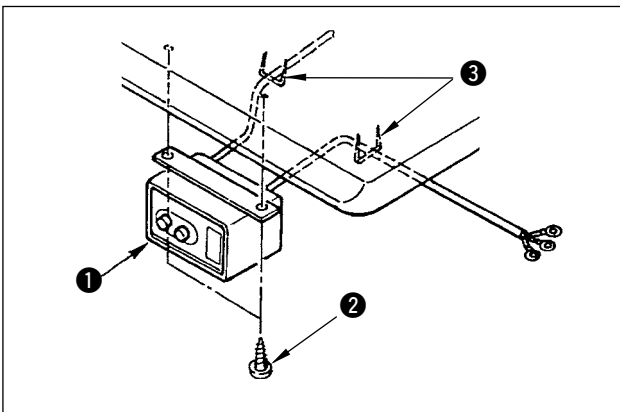

#### 1) Installing the power switch

Fix power switch **1** under the machine table with wood screws **2**.

Fix the cable with staples **3** supplied with the machine as accessories in accordance with the forms of use.



Five staples **3** including the staple for fixing the operation panel cable are supplied as accessories.

(2) Connecting the power source cord

Voltage specifications at the time of delivery from the factory are indicated on the voltage indication seal. Connect the cord in accordance with the specifications.

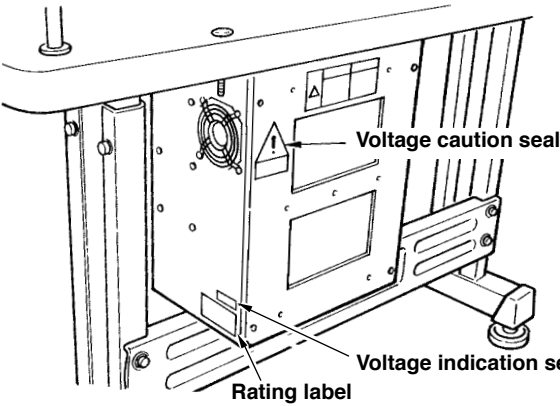

**Caution**

1. Never use under the wrong voltage and phase.
2. When changing the voltage, refer to the item of "III-1-11. Changing the voltage of 100↔200V" p.127.

**• Connecting single phase 200V, 220V, 230V and 240V**

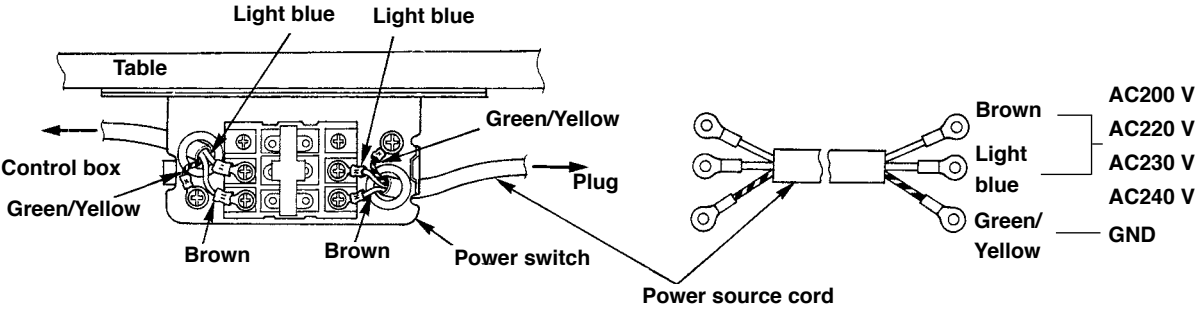

**• Connecting three phase 200V, 220V and 240V**

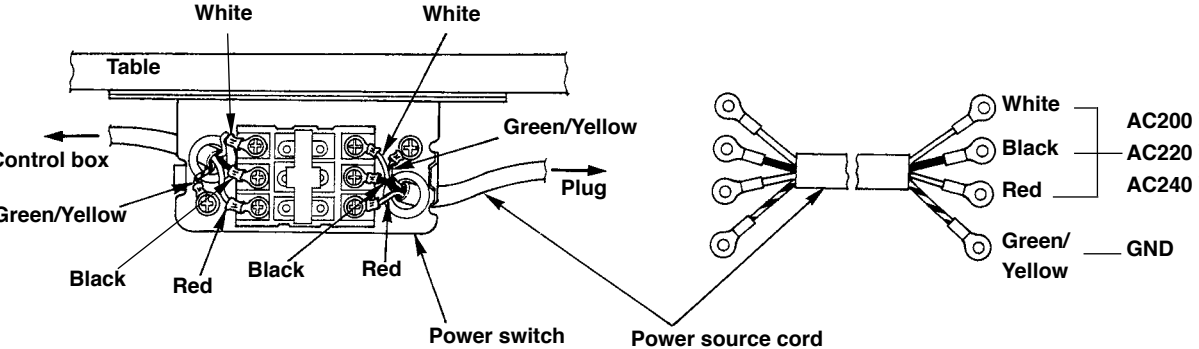

**3-3. Installation of the sewing machine head**



**WARNING :**

To prevent possible accidents caused by the full of the sewing machine, perform the work by two persons or more when the machine is moved.

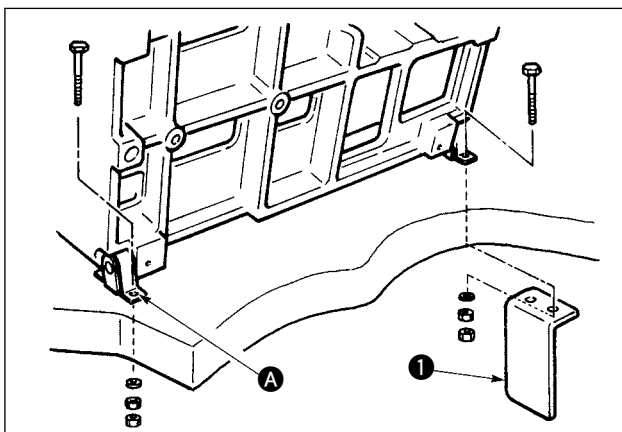

1) Fit the holes of hinges **A** to the holes of table and fix as shown in the figure.

**Reference**

In case of the pneumatic type, fix solenoid valve installing plate **1** as well.



### 3-4. Installing the drain receiver and the head support rubber

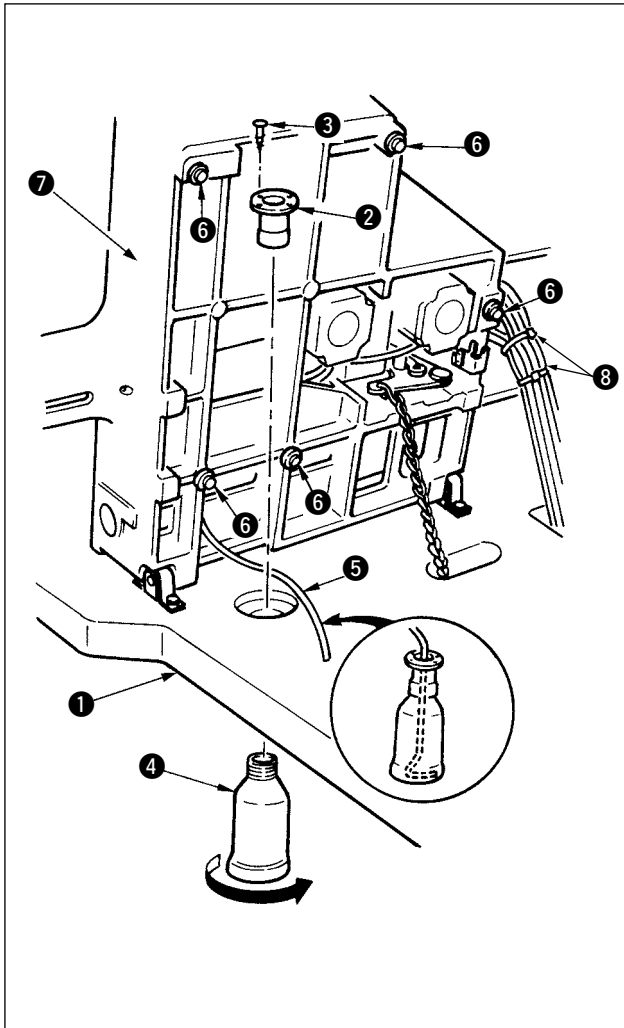

- 1) Fix drain receiver ② in the installing hole of table ① with two setscrews ③.
- 2) Screw in drain bin ④ to drain receiver ②.
- 3) Insert sewing machine drain pipe ⑤ into drain bin ④.
- 4) Insert head support rubbers ⑥ to machine bed ⑦.
- 5) Bundle the cables with clip bands ⑧ as shown in the figure. (Excluding air tube)



1. Insert drain pipe ⑤ until it will go no further so that it does not come off drain bin ④ when tilting the machine head.
2. Remove the tape fixing drain pipe ⑤.

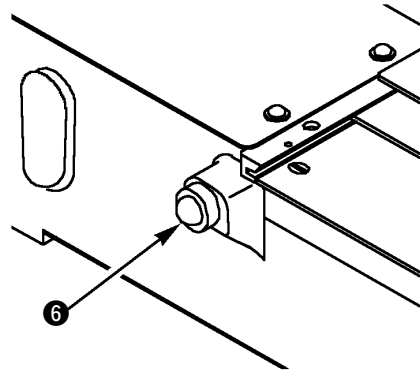

### 3-5. Safety switch

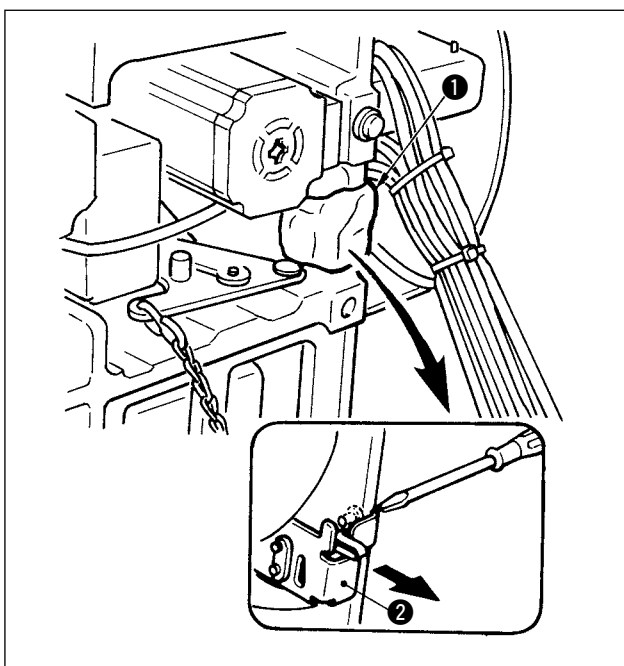

Remove tape ② fixing the lever section of safety switch ①.



1. When using the safety switch without removing tape ①, it is very dangerous since the sewing machine works even in the state that it is tilted.
2. In case error 302 occurs when the sewing machine works after setup, loosen the safety switch ② fitting screw with a screwdriver, and lower the switch to the down-side of the sewing machine.

### 3-6. Installing the throat plate auxiliary cover

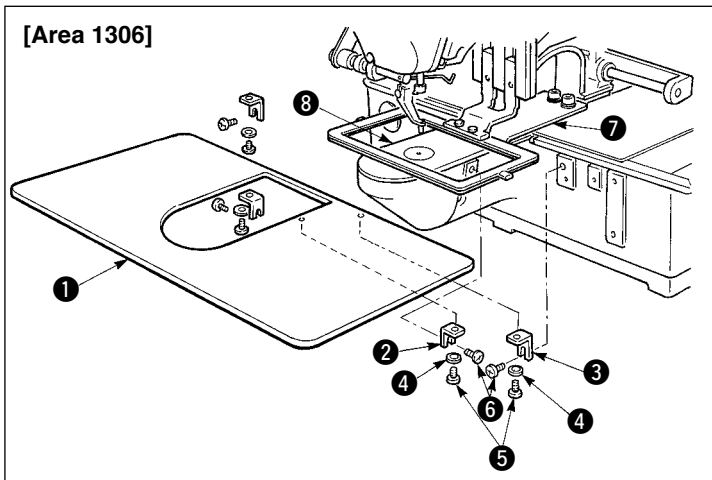

#### [When using area 1306]

- 1) Temporarily fix throat plate auxiliary cover supports A **2** and B **3** to the machine bed with setscrews (M5) **6**.
- 2) Move the cloth feed base to the rear, and place throat plate auxiliary cover **1** from between lower plate **7** and throat plate **8**. At this time, be careful not to bend lower plate **7**.
- 3) Fix throat plate auxiliary cover **1** with throat plate auxiliary cover setscrews **5** and washers **4**.

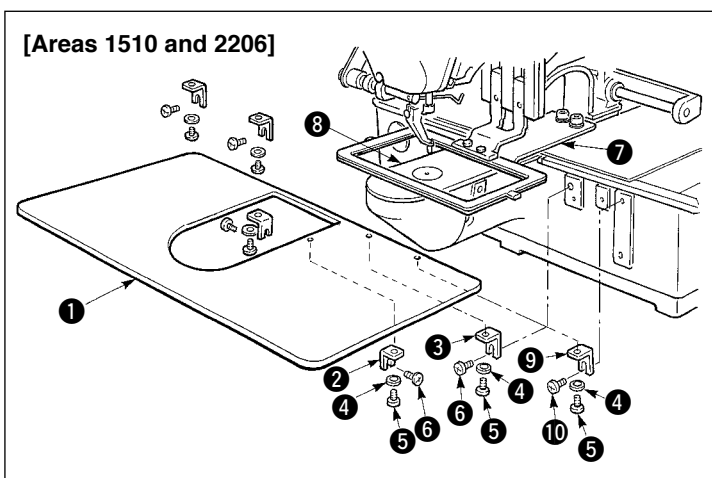

#### [When using areas 1510 and 2206]

- 1) Temporarily fix throat plate auxiliary supports A **2** and B **3** to the machine bed with setscrews (M5) **6** and throat plate auxiliary support C **9** to the machine bed with setscrew (M6) **10**.
- 2) Move the cloth feed base to the rear, and place throat plate auxiliary cover **1** from between lower plate **7** and throat plate **8**. At this time, be careful not to bend lower plate **7**.
- 3) Fix throat plate auxiliary cover **1** with throat plate auxiliary cover setscrews **5** and washers **4**.

[Area 2210]

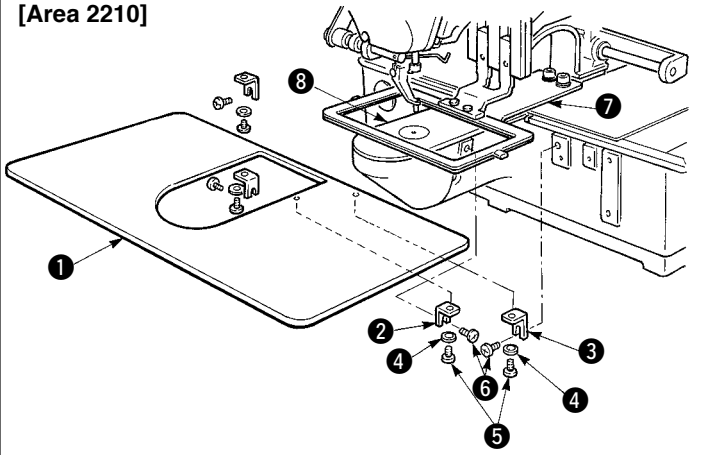

[Area 2210]

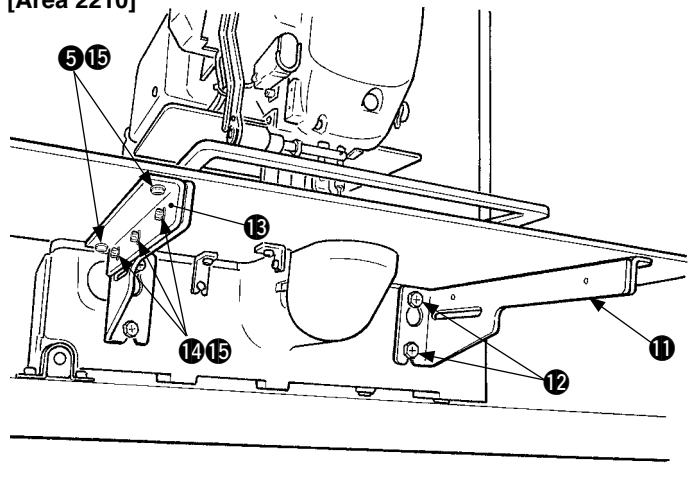

[When using area 2210]

- 1) Temporarily fix throat plate auxiliary cover supports A ② and B ③ to the machine bed with setscrews (M5) ⑥.



For the screw ⑥ which tightens the throat plate auxiliary cover support A ②, select the screw which is easier to use between the hexagon socket and the screw with plus and minus slots.

- 2) Move the cloth feed base to the rear, and place throat plate auxiliary cover ① from between lower plate ⑦ and throat plate ⑧. At this time, be careful not to bend lower plate ⑦.
- 3) Fix throat plate auxiliary cover ① with throat plate auxiliary cover setscrews ⑤ and nuts (small) ④.
- 4) Temporarily fix throat plate auxiliary cover support ⑪ to the machine bed with setscrews (M6) ⑫.
- 5) Temporarily fix throat plate auxiliary cover base ⑬ to throat plate auxiliary cover support ⑪ with setscrews ⑭ and nuts (large) ⑮.
- 6) Fix throat plate auxiliary cover ① with throat plate auxiliary cover setscrews ⑤ and nuts (large) ⑮.



Left-hand and right-hand shapes of throat plate auxiliary cover support ⑪ are different. So, be careful.

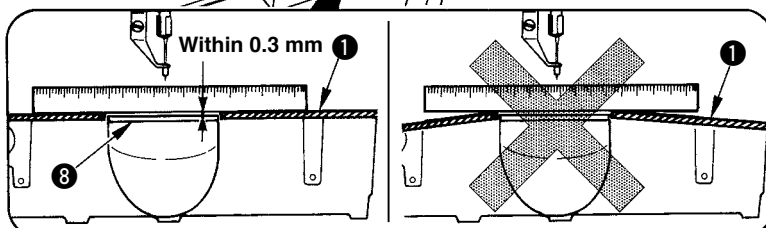
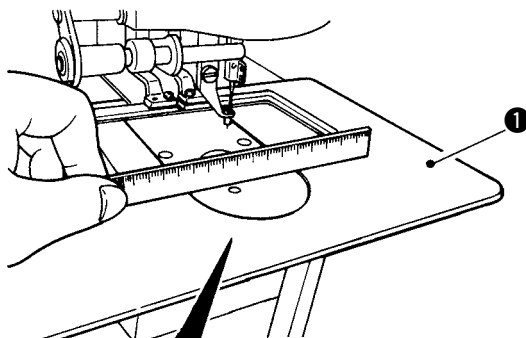

1. Be careful so as not to mistake the direction of throat plate auxiliary cover support.
2. Fix the throat plate auxiliary cover ① so that is higher than the throat plate ⑧ (within 0.3 mm). When it is lower than the throat plate ⑧, needle breakage or the like due to the defective feed will be caused.
3. Confirm by putting a ruler or the like that the throat plate auxiliary cover ① is horizontally installed. If not, throat plate auxiliary cover ① and lower plate ⑦ come in contact partially with each other, and abnormal worn-out will be caused.

### 3-7. Installing the panel

#### 1) Installing the IP-410

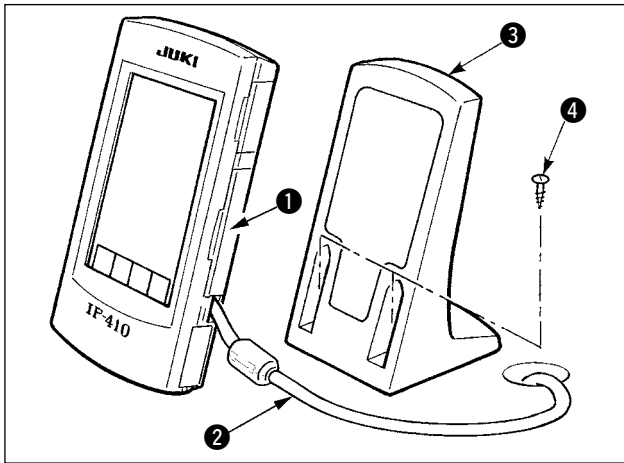

- 1) Open cover ① and remove cable ② once. Then connect it again to the panel on the top surface of the table after passing it through the hole in the table.
- 2) Fix operation panel installing plate ③ to an optional place on the table with two wood screws ④.



**Install the panel at the position where X-move cover or head grip does not interfere with it since breakage of the panel will be caused.**

#### 2) Installing the CP-20

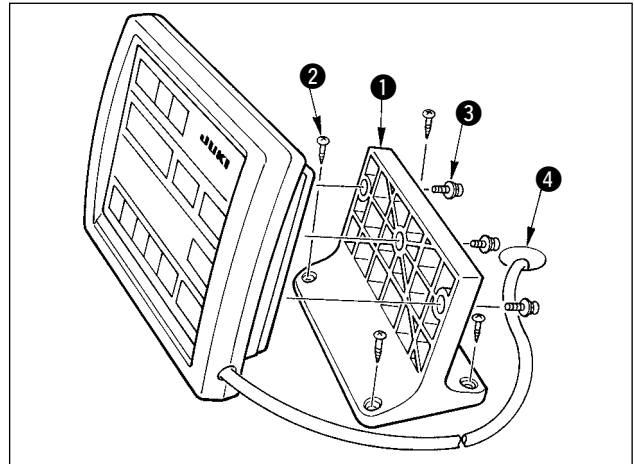

Fix operation panel installing plate ① to an optional place on the table with wood screws ②, and pass the cable through table hole ④. Fix the operation panel on panel installing plate ① with screws ③ supplied as accessories. Fix the cable on the bottom surface of the table with the staples supplied with the machine as accessories.

### 3-8. Attaching the pedal chain (For S specification only)

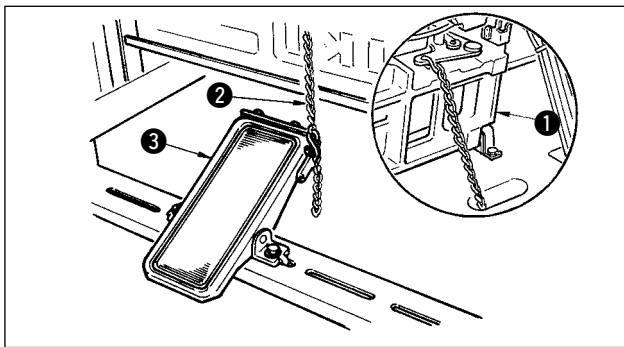

Connect the machine ① and manual pedal ③ with chain ②.



**When you tilt the sewing machine, be sure to tilt it after removing chain ② from manual pedal ③.**

### 3-9. Installing the thread stand

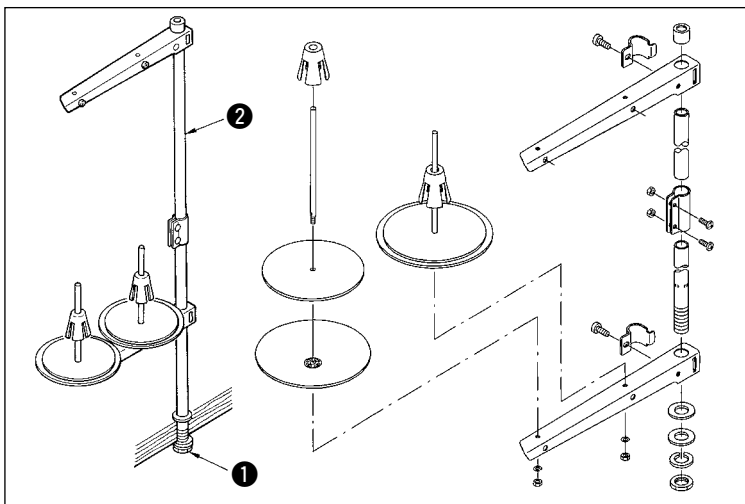

- 1) Assemble the thread stand, and put it in the hole in the top left corner of the machine table.
- 2) Tighten locknut ① to fix the thread stand.
- 3) When ceiling wiring is possible, pass the power cord through spool rest rod ②.

### 3-10. Raising the machine head

**WARNING :**



Tilt/raise the sewing machine head with both hands taking care not to allow your fingers to be caught in the head.  
Turn OFF the power before starting the work so as to prevent accidents caused by abrupt start of the sewing machine.

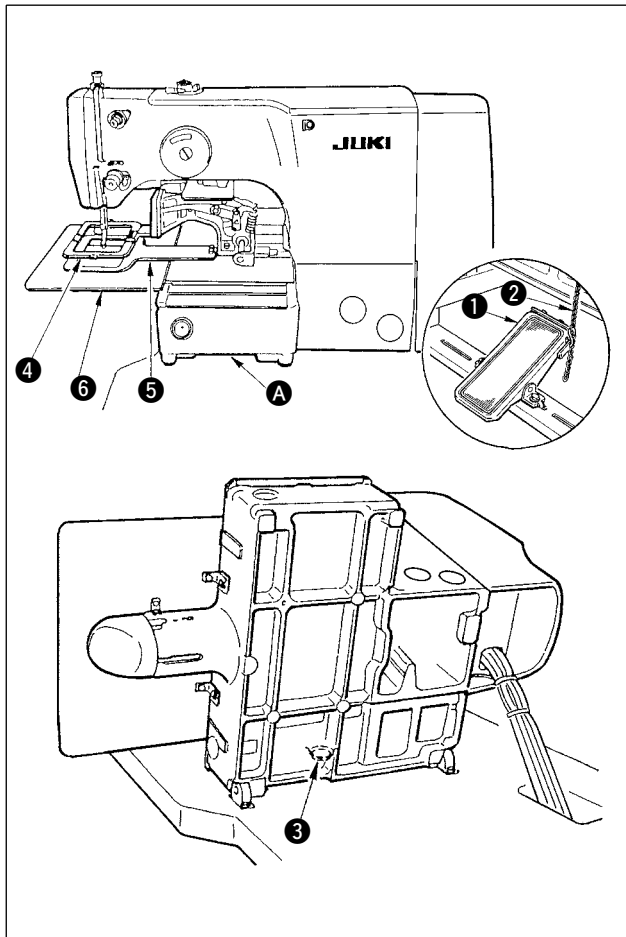

**[When using areas 1306 and 1510]**

When raising the sewing machine, hold inserting section **A** of the machine bed by hand, and quietly raise it until bed support rubber **3** comes in contact with the table. For the S type, remove chain **2** from manual pedal **1** first, and perform the work.

1. Be sure to raise the machine head at the leveled place so as to prevent the sewing machine from falling.
2. When raising the machine head, move feeding frame **4** beforehand to the right-hand side until it goes no further, and fix it with tape or the like. When the machine head is raised in the state that moving or fixing is insufficient, breakage of X-move cover or X-move rail will be caused. Besides, feeding frame **4** which is tilted to the left-hand side by the self-weight interferes with the intermediate presser or the like and breakage of the components will be caused.



**[Areas 2206 and 2210]**

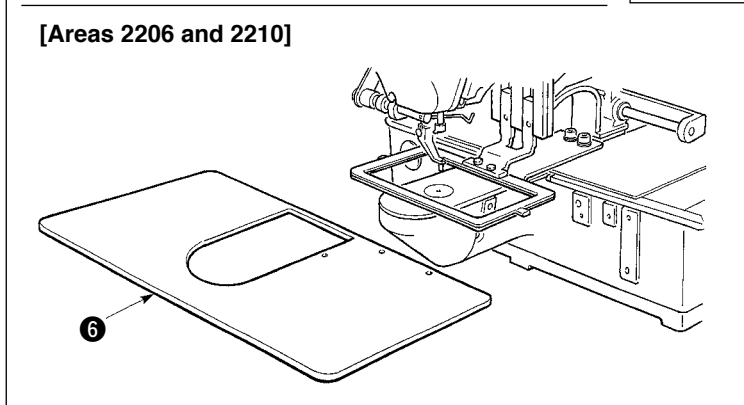

**[When using areas 2206 and 2210]**

- 1) Remove throat plate auxiliary cover **6** from the sewing machine.
- 2) Hold inserting section **A** of the machine bed by hand, and quietly raise it until bed support rubber **3** comes in contact with the table.
- 3) After returning the sewing machine to its home position, refer to "I-3-6. Installing the throat plate auxiliary cover" p.6, and install the throat plate auxiliary cover.

1. Be sure to raise the machine head at the leveled place so as to prevent the sewing machine from falling.
2. When raising the sewing machine without removing throat plate auxiliary cover **6**, the throat plate auxiliary cover interferes with the table, bend or breakage of the throat plate auxiliary cover, tilt of the sewing machine, etc. will result.
3. When raising the machine head, move feeding frame **4** beforehand to the right-hand side until it goes no further, and fix it with tape or the like. When the machine head is raised in the state that moving or fixing is insufficient, breakage of X-move cover or X-move rail will be caused. Besides, feeding frame **4** which is tilted to the left-hand side by the self-weight interferes with the intermediate presser or the like and breakage of the components will be caused.



### 3-11. Connecting the cord

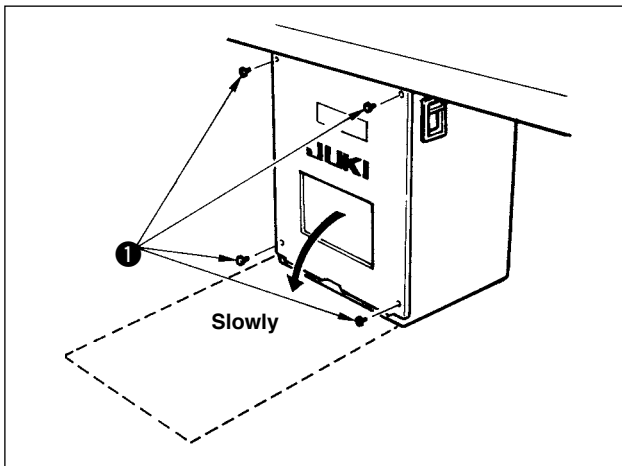

#### [How to open the control box]

Remove four screws ① fixing the rear cover of the electrical box. When opening the rear cover, pressing it with your hands, slowly open it by approximately 90° until it stops as illustrated.



Be sure to lend your hand to the rear cover in order not to let the rear cover fall. In addition, do not apply force to the rear cover opened.

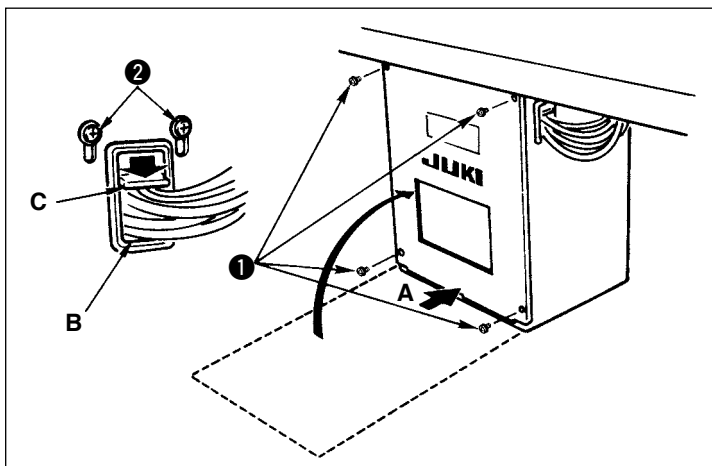

#### [How to close the control box]

- 1) Take care so that the cord is not caught between the rear cover and the electrical box main body, close the rear cover while pressing section A on the lower side of the rear cover, and tighten four screws ①.
- 2) Lower downward the cord located on the side of the control box and cord presser plate C in the push hole B, press the cord and tighten screws ②.

#### How to lock the cord clamp

- ① Lightly press the corner of clamp. (Cord clamp is locked with a click.)

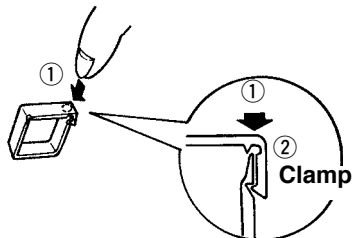

#### How to remove the cord clamp

- ① Lightly pressing
- ② Pull down the clamp.
- ③ The clamp goes up.

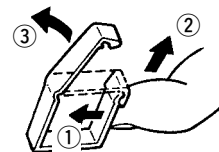
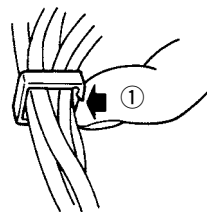

When fixing the cord with the cord clamp, be careful of the route or the like so that the stress is not applied to the cord.

[Wiring diagram of circuit board]

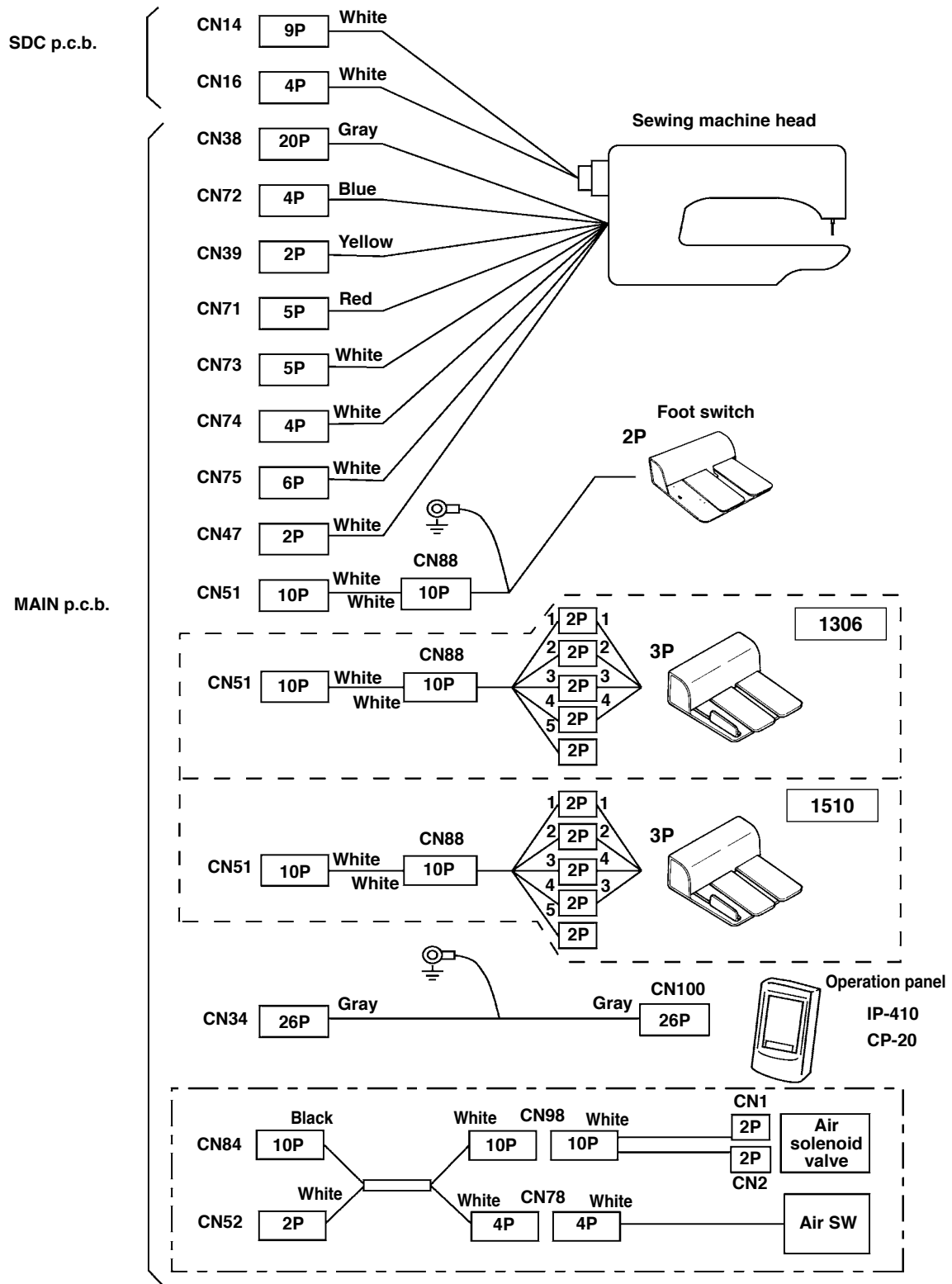

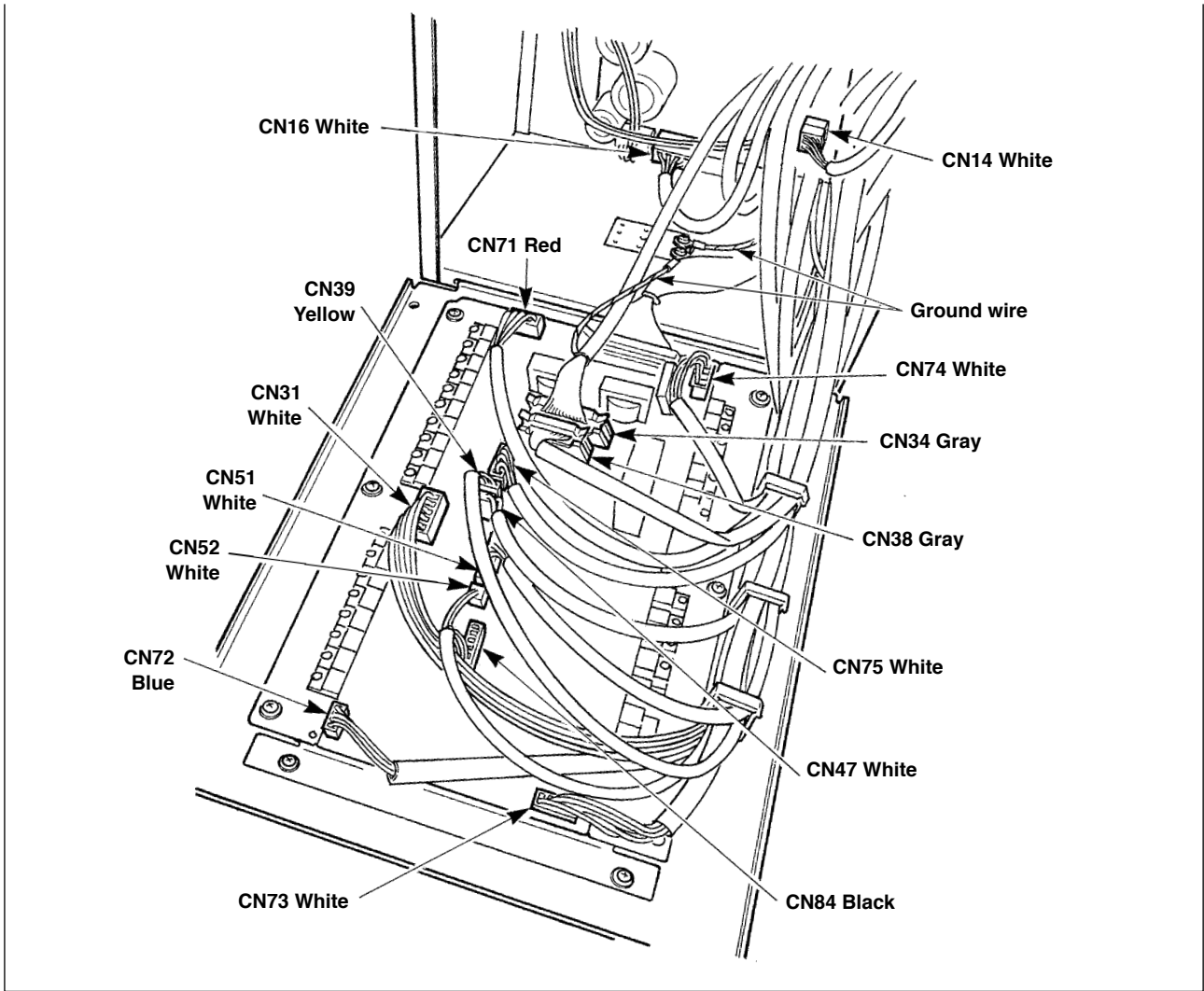

**3-12. Installing the motor cover**

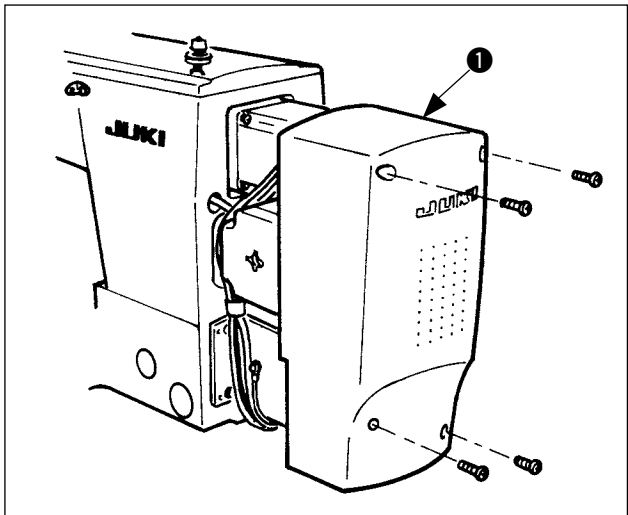

Install motor cover ❶ on the machine main unit with screws supplied with the machine as accessories.



### 3-13. Managing the cord

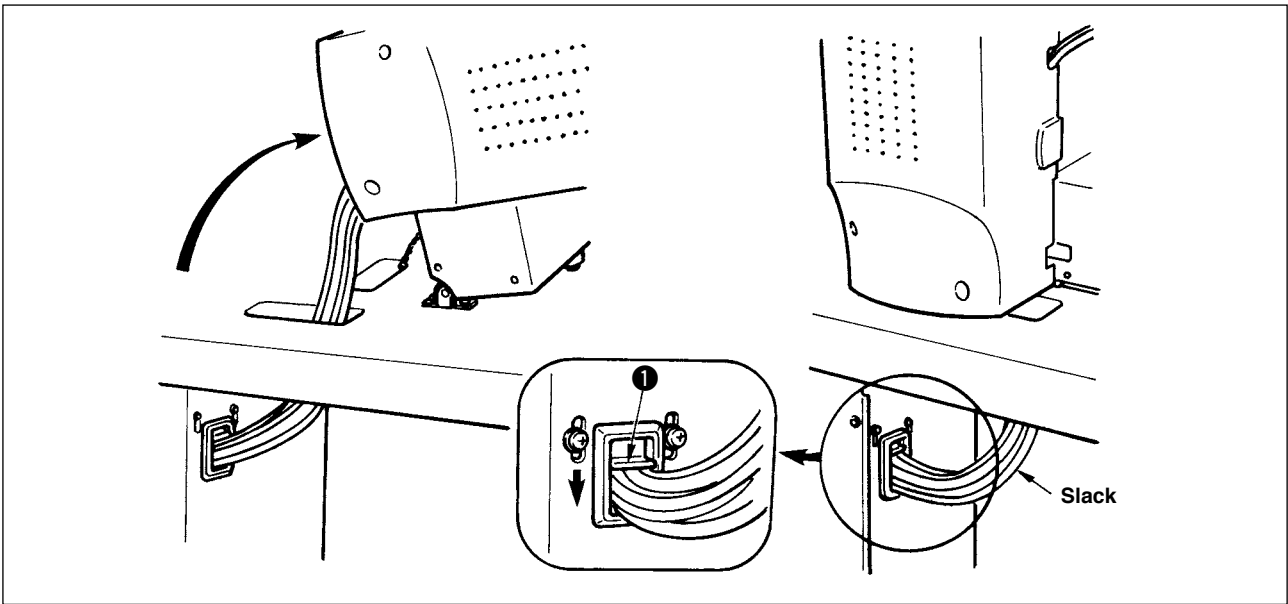

- 1) Fix the cords with cords setting plate ❶ in the state that the cords are slack to such an extent that stress is not applied to the cords even when the machine head is tilted as shown in the figure.

### 3-14. Connecting the pneumatic components (Pneumatic type only)

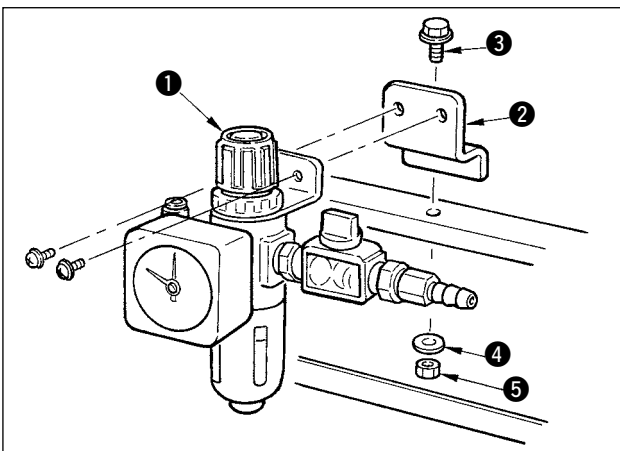

- 1) Install regulator ❶ to installing plate ❷, and install it to the stand with screw ❸, washer ❹ and nut ❺.
- 2) Connect the cord coming from the regulator with CN78 (air relay cable).  
(Refer to "I-3-11. [Wiring diagram of circuit board]" p.11.)

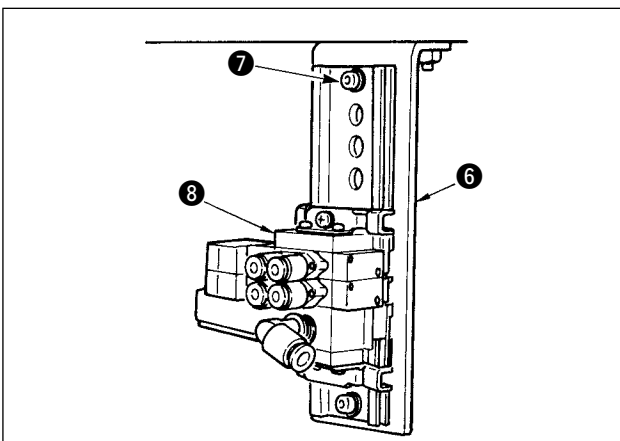

- 3) Install solenoid valve asm. ❸ to solenoid valve installing plate ❹ using setscrew ❺ supplied as accessories.

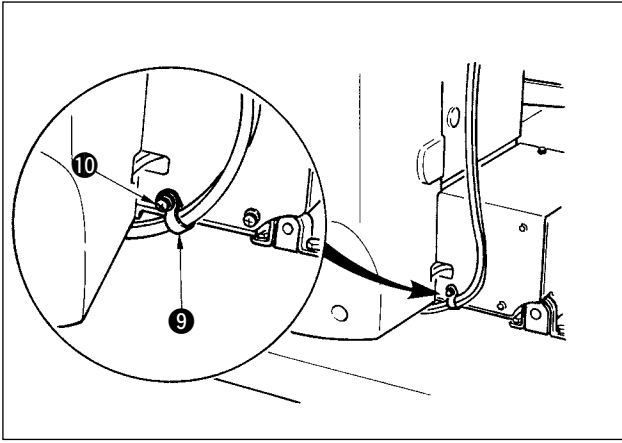

- 4) Fix the air tube using cable clip **9** supplied with the machine as accessories. (For the setscrew, use setscrew **10** fixing the motor cover.)

**[When using areas 1306, 1510 and 2206]**

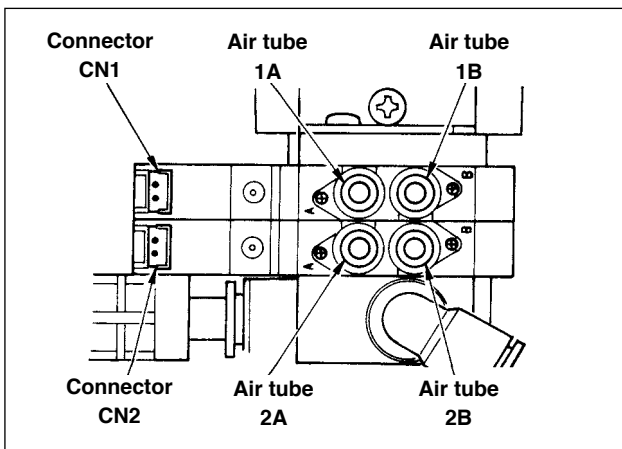

- 5) Install air tubes coming from the machine head and the cords coming from the control box to the position as shown in the figure. At this time, be careful of the number and alphabet of the air tubes and the cords. (Adjust the alphabet of the air tubes to the alphabet of the solenoid valve. Also, adjust the figures to the figures of the connector label.)

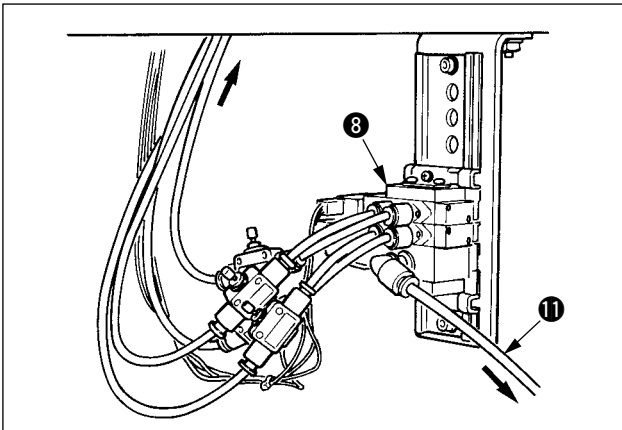

- 6) Connect solenoid valve asm. **8** and the regulator using long air tube supplied **11** as accessories.

**Caution** When the cable sags, fix it to the table using the staple supplied with the machine as accessories.

[When using area 2210]

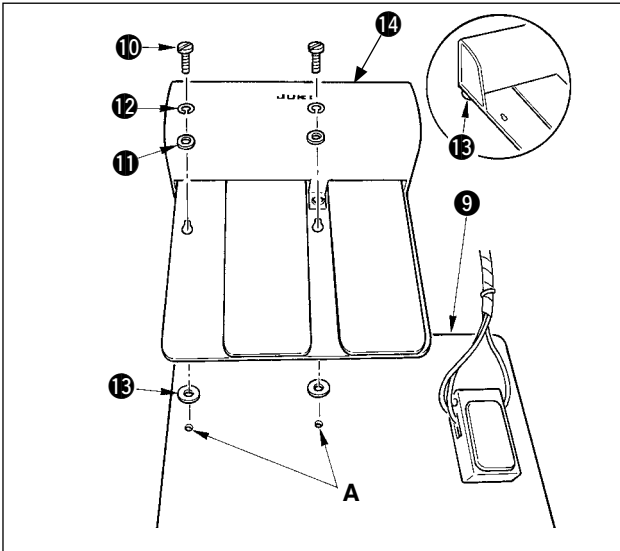

- 5) Remove once two setscrews **10**, two washers (small) **11**, two spring washers **12** and two washers (large) **13** attached to mechanical valve unit **9**. Refer to the figure, and install 2-pedal type pedal **14** into hole **A** of mechanical valve unit **9**.

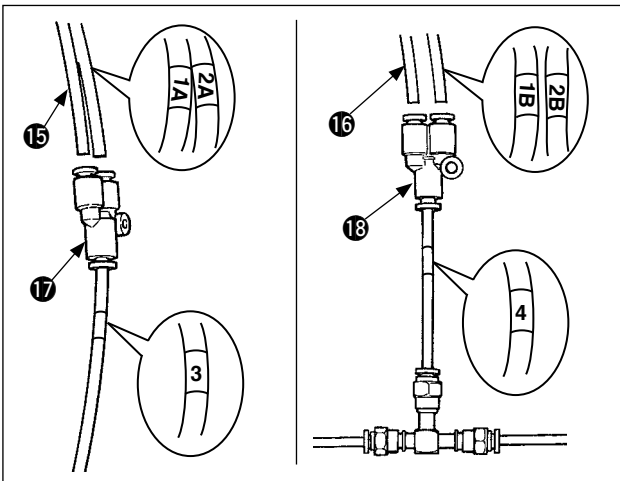

- 6) Connect the air tubes coming from the machine head and Y-type joint respectively as described below.
- Air tube **15** with label of "1A, 2A"  
→ Y-type joint **17** connected with the label of "3" of mechanical valve unit
  - Air tube **16** with label of "1B, 2B"  
→ Y-type joint **18** connected with the label of "4" of mechanical valve unit

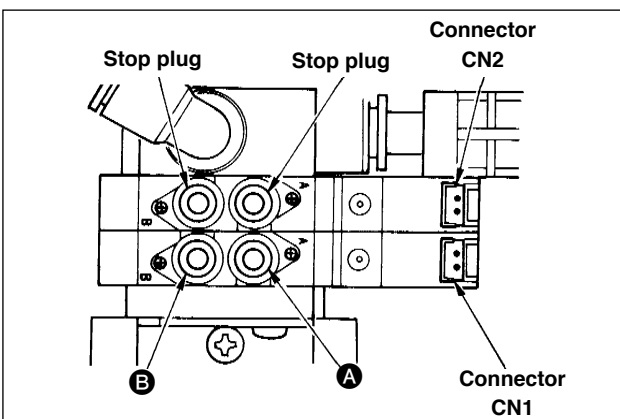

- 7) Install the air tube coming from mechanical valve unit "7" to **A**, and that from "8" to **B** respectively. Install two stop plugs supplied as accessories, and the cords coming from the control box to the places in the figure.

**Reference** When the mechanical valve is not used, refer to [When using areas 1306, 1510 and 2206].

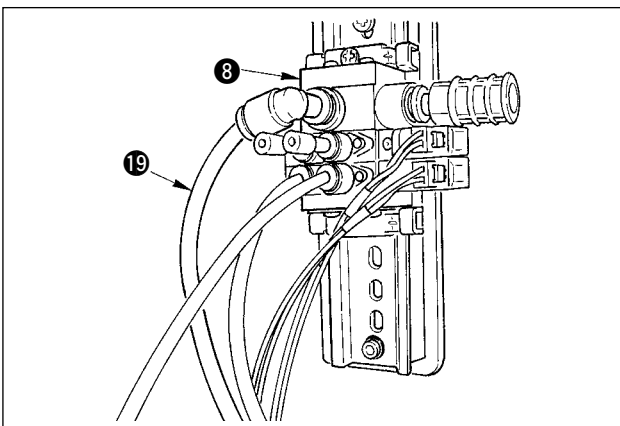

- 8) Connect solenoid valve asm. **8** and the regulator using long air tube supplied **19** as accessories.

**Caution** When the cable sags, fix it to the table using the staple supplied with the machine as accessories.

### 3-15. Installing the air hose (Pneumatic type only)

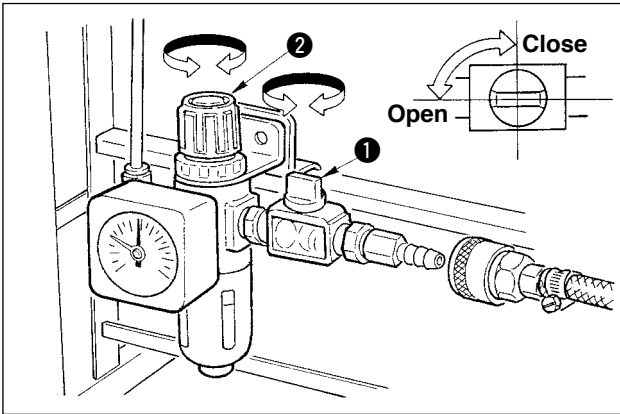

- 1) Connecting the air hose  
Connect the air hose to the regulator .
  - 2) Adjustment of air pressure  
Open air cock ①, pull up and turn air adjustment knob ② and adjust so that air pressure indicates 0.35 to 0.4 MPa (Max. 0.55 MPa).  
Then lower the knob and fix it.
- \* Close air cock ① to expel air.

### 3-16. Installing the eye protection cover



**WARNING :**

Be sure to attach this cover to protect the eyes from the disperse of needle breakage.

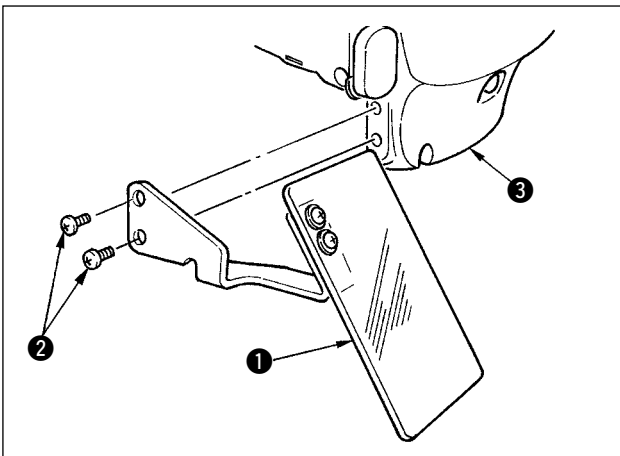

Use eye protection cover ① after securely attaching it on face plate cover ③ with screw ②.

## 4. PREPARATION OF THE SEWING MACHINE

### 4-1. Lubrication



#### WARNING :

Turn OFF the power before starting the work so as to prevent accidents caused by abrupt start of the sewing machine.

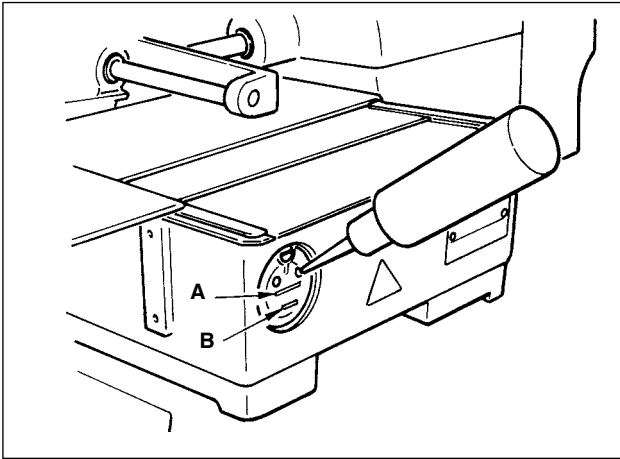

Check that the place between lower line **B** and upper line **A** is filled with oil. Fill there with oil using the oiler supplied with the machine as accessories when oil is short.



The oil tank which is filled with oil is only for lubricating to the hook portion. It is possible to reduce the oil amount when the number of rotation used is low and the oil amount in the hook portion is excessive. (Refer to “[III-1-9. Amount of oil supplied to the hook](#)” p.126 .)



1. Do not lubricate to the places other than the oil tank and the hook of Caution 2 below. Trouble of components will be caused.
2. When using the sewing machine for the first time or after an extended period of disuse, use the machine after lubricating a small amount of oil to the hook portion. (Refer to “[III-1-2. Adjusting the needle-to-shuttle relation](#)” p.121. )

## 4-2. Attaching the needle



### WARNING :

Turn OFF the power before starting the work so as to prevent accidents caused by abrupt start of the sewing machine.

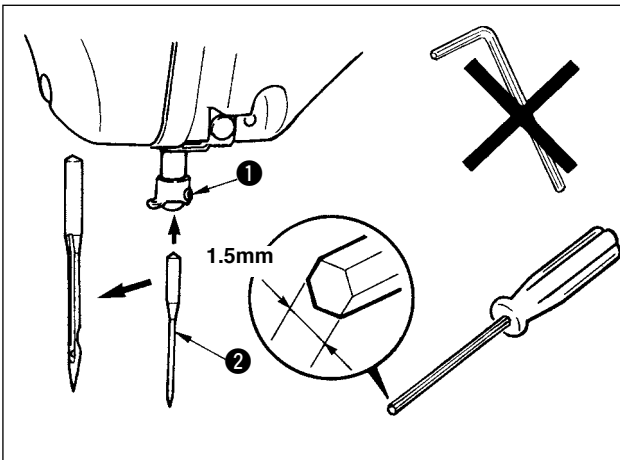

Loosen setscrew ① and hold needle ② with the long groove facing toward you. Then fully insert it into the hole in the needle bar, and tighten setscrew ①.



When tightening setscrew ①, be sure to use the screwdriver (Part No. : 40032763) supplied as accessories. Do not use L-shaped hexagon wrench. There is a danger of breaking setscrew ①.

## 4-3. Threading the machine head



### WARNING :

Turn OFF the power before starting the work so as to prevent accidents caused by abrupt start of the sewing machine.

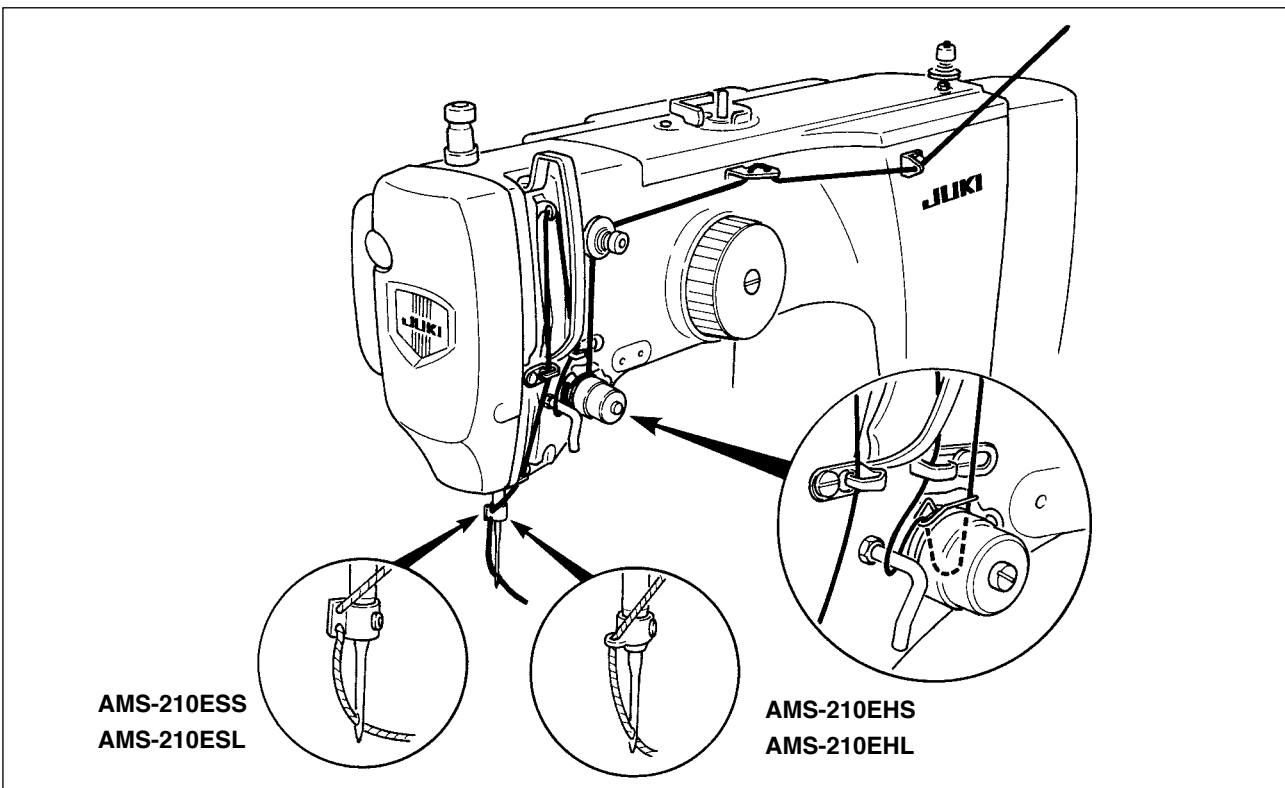

#### 4-4. Installing and removing the bobbin case



**WARNING :**

Turn OFF the power before starting the work so as to prevent accidents caused by abrupt start of the sewing machine.

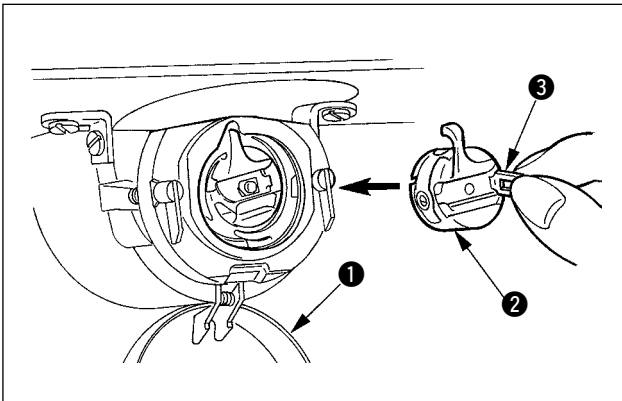

- 1) Open hook cover ①.
- 2) Raise latch ③ of bobbin case ②, and remove the bobbin case.
- 3) When entering bobbin case, insert it with the latch tilted until "click" sounds.



If it is not fully inserted, bobbin case ② may slip off during sewing.

#### 4-5. Installing the bobbin



**WARNING :**

Turn OFF the power before starting the work so as to prevent accidents caused by abrupt start of the sewing machine.

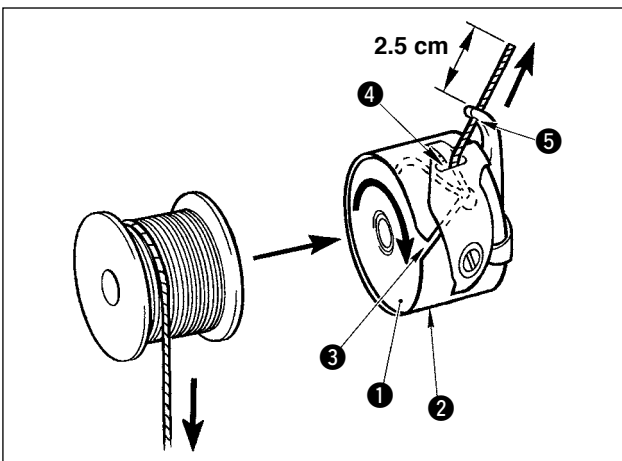

- 1) Set the bobbin ① into bobbin case ② in the direction shown in the figure.
- 2) Pass the thread through thread slit ③ of bobbin case ②, and pull the thread as it is. By so doing, the thread will pass under the tension spring and be pulled out from thread hole ④.
- 3) Pass the thread through thread hole ⑤ of the horn section, and pull out the thread by 2.5 cm from the thread hole.



If the bobbin is installed in the bobbin case orienting the reverse direction, the bobbin thread pulling out will result in an inconsistent state.

## 4-6. Adjusting the thread tension

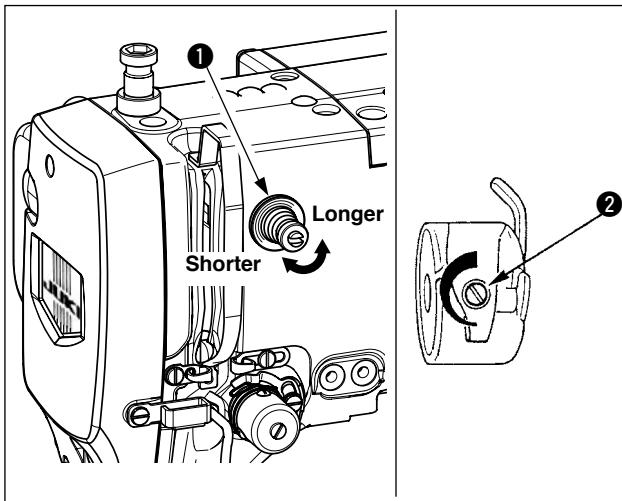



If thread tension controller No. 1 **1** is turned clockwise, the length of remaining thread on the needle after thread trimming will be shorter. If it is turned counterclockwise, the length will be longer. Shorten the length to an extent that the thread is not slipped off.

Adjust needle thread tension from the operation panel and bobbin thread tension with **2**.

### Adjusting the needle thread tension

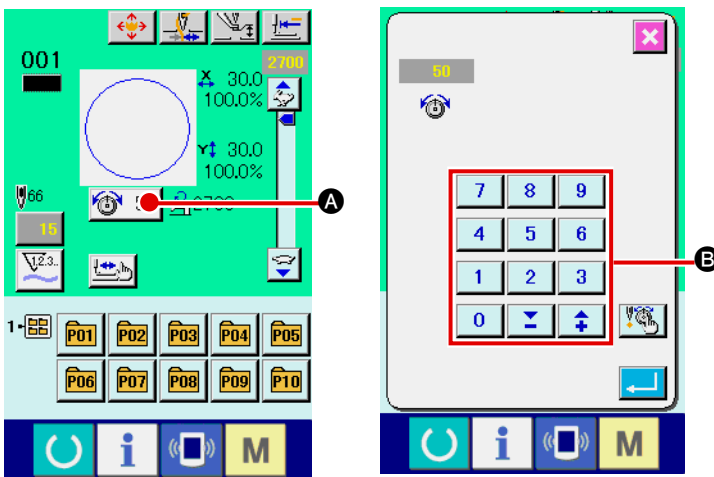
[IP-410]





1) Select THREAD TENSION button  50 **A** in the sewing screen.

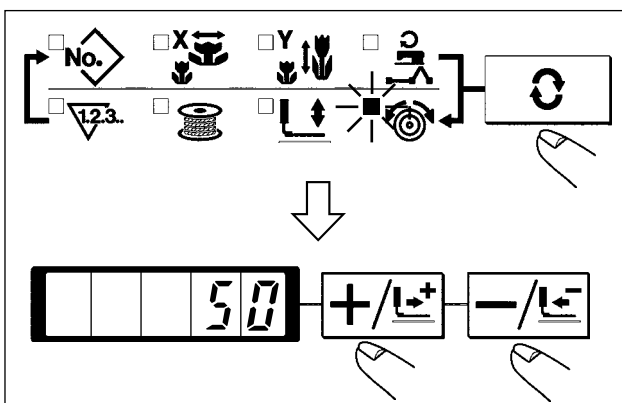

2) Set needle thread tension with TEN keys **B**. There is a setting range of 0 to 200. When the set value is increased, the tension becomes higher.

\* When the set value is 50 at the time of standard delivery, the thread tension is adjusted so that H type is 2.35N and S type is 1.47N (spun thread #50). (When thread tension No. 1 is released)

[CP-20]



1) Select thread tension  with  key.

2) Set needle thread tension with  key or  key. There is a setting range of 0 to 200. When the set value is increased, the tension becomes higher.

\* When the set value is 50 at the time of standard delivery, the thread tension is adjusted so that H type is 2.35N and S type is 1.47N (spun thread #50). (When thread tension No. 1 is released)



## 4-7. Intermediate presser height



When raising the intermediate presser height, turn the pulley by hand to lower the needle bar, and confirm that the needle bar does not interfere with the intermediate presser. (When using DP X 5 needle, use the sewing machine with the height of 3.5 mm or less.)

[IP-410]

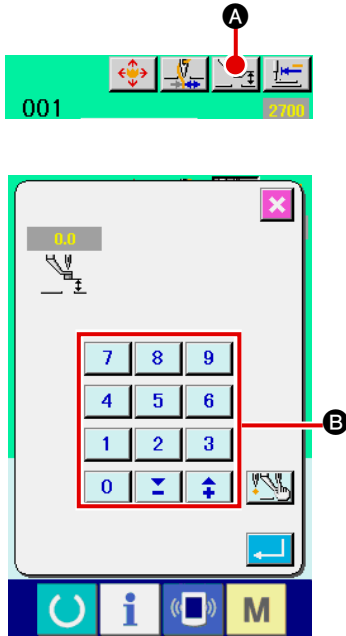

Press INTERMEDIATE PRESSER SETTING button **A** and adjust with TEN keys **B** so that the clearance between the bottom end of intermediate presser and the cloth is 0.5 mm (thickness of thread used).

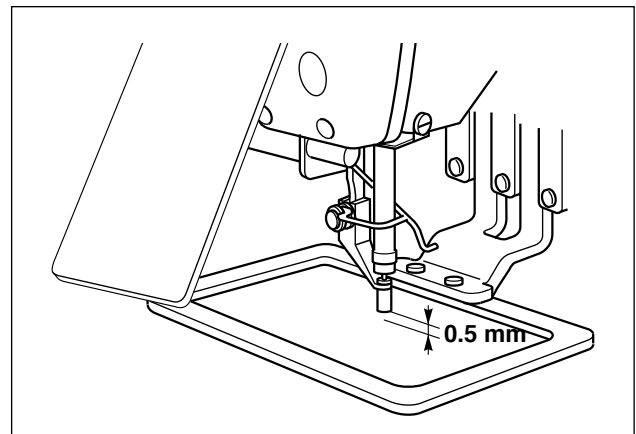

[CP-20]

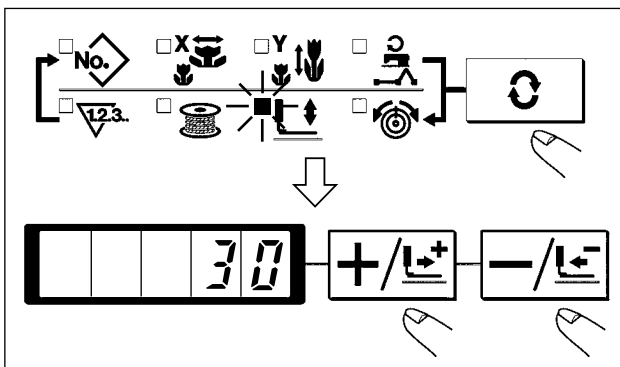

- 1) Select the intermediate presser with **C** key.
- 2) Press **C** key to lower the intermediate presser.
- 3) Adjust with **+/-** or **-/+** key so that the clearance between the bottom end of intermediate presser and the cloth is 0.5 mm (thickness of thread used) when the needle is in its lowest position.



1. Setting range of the intermediate presser is up to the standard of 3.5 mm. However, when using DP X 17 needle for H type or the like, the setting range can be changed up to max. 7 mm with memory switch U112.
2. When increasing the height of intermediate presser or making the needle size thicker, confirm the clearance between the wiper and the components. Wiper cannot be used unless the clearance is secured. In this case, turn OFF the wiper switch, or change the set value of memory switch U105.

## 4-8. Adjusting the thread take-up spring

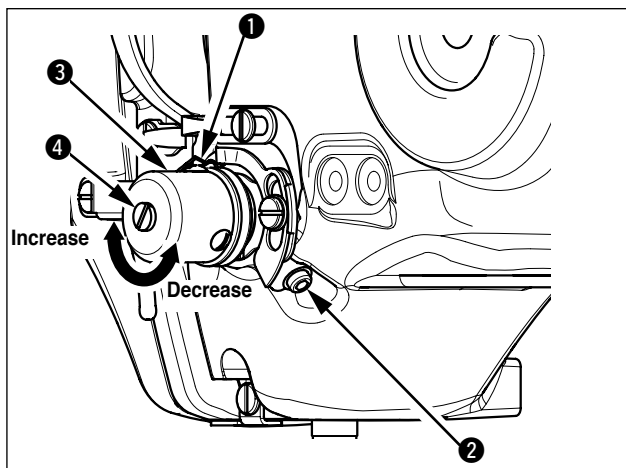

- 1) Adjusting the stroke  
Loosen setscrew ②, and turn thread tension asm. ③. Turning it clockwise will increase the moving amount and the thread drawing amount will increase.
- 2) Adjusting the pressure  
To change the pressure of the thread take-up spring ①, insert a thin screwdriver into the slot of thread tension post ④ while screw ② is tightened, and turn it. Turning it clockwise will increase the pressure of the thread take-up spring. Turning it counterclockwise will decrease the pressure.

## 5. OPERATION OF THE SEWING MACHINE

### 5-1. Sewing

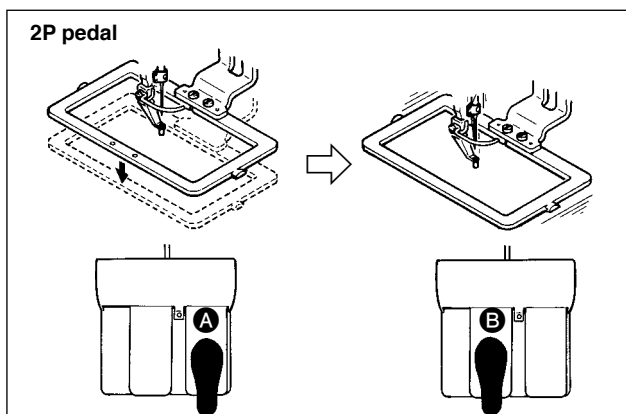

[In case of 2P pedal]

- 1) Set a workpiece on the sewing machine.
- 2) Depress the pedal switch ①, and the feeding frame will come down. Depress it again, and the feeding frame will go up.
- 3) Depress the pedal switch ② after the feeding frame has come down and the sewing machine will start sewing.
- 4) After the sewing machine completes sewing, the needle point will return to the start point and the feeding frame will go up.

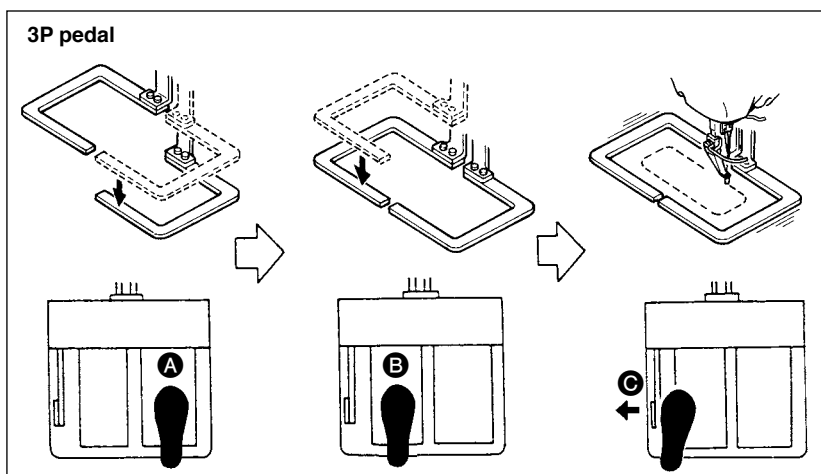

[In case of 3P pedal]



- 1) Set a workpiece on the sewing machine.
- 2) When pedal switch ① is depressed, the right-hand presser comes down, and when it is depressed again, the presser goes up. When pedal switch ② is depressed, the left-hand presser comes down, and when it is depressed again, the presser goes up.
- 3) Depress the pedal switch ③ after the feeding frame has come down and the sewing machine will start sewing.
- 4) After the sewing machine completes sewing, the needle point will return to the start point and the feeding frame will go up.





**When using the area 1510 with the standard method, the use of 3P pedal is the same as that of 2P pedal. Refer to [In case of 2P pedal].**

**When using the pedal as 3P pedal by remodeling the presser or the like, it is necessary to change the connecting procedure of the pedal and memory switches U81 and U82.**

## 5-2. Needle thread clamp device

By actuating the needle thread clamp device, trouble of sewing at the high-speed start (needle thread slip-off, stitch skipping or needle thread stain) is prevented, and can reduce gathering (bird's nest) of needle thread on the wrong side of cloth while keeping stable sewing. Needle thread clamp device operates in the state that thread clamp display LED is lit, and does not operate when it goes off. When mounting the IP-410, changeover of motion ON/OFF is performed with  key, and when mounting the CP-20, changeover of motion ON/OFF is performed with  key respectively. When the needle thread clamp device is OFF, the machine automatically operates at slow-start.



**When memory switch No. 35 is "1" (prohibited), the thread clamp does not work. In addition,  and  key is ineffective.**

For the thread clamp unit, there are S type and H type in accordance with the sewing types. Refer the respective types and the contents of the memory switches that can be set to the list below.

Sewing machine type	Thread clamp unit type	Memory switch	
		U69	U70
AMS-210ESS AMS-210ESL	S type	0 : S type (standard)	0 : Front (standard)
AMS-210EHS AMS-210EHL	H type	1 : H type thin thread (standard) (#50 to #8) 2 : H type intermediate 3 : H type thick thread (#5 to #2)	0 : Front (standard) or 1 : Rear

[Regarding H type thread clamp unit]

Change the set value of memory switch U69 in accordance with the thickness of needle thread. The set value has been set to 1 : H type thin thread at the time of delivery. Commendable value is Set value : 1 for thread count #50 to #8, and that is Set value : 3 for thread count #5 to #2. (The value will change in accordance with the kind and thickness of the actual thread and the kinds of materials to be sewn.) Set the value by adjusting to the state of needle thread on the wrong side of materials.



In addition, it is possible to select the thread clamp position by means of memory switch U70. When using thick thread of thread count #5 to #2, and rolling-in or tucking at the start of sewing occurs, set the set value to 1 : Rear and use the machine.

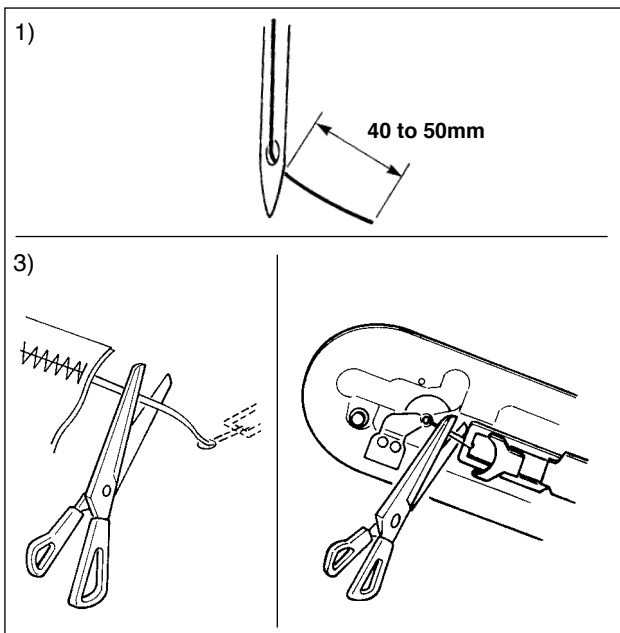

**Use the set value of the memory switch which is adjusted to the thread clamp unit type. (For S type thread clamp unit, the set value of U69 and U70 can use nothing but only "0". When the setting is wrong, the thread clamp fails to properly function. So, be careful.**

(1) When with thread clamp (motion), use the sewing machine after adjusting the needle thread length at the start of sewing to 40 to 50 mm. When the needle thread length is too long, the needle thread end held with the needle thread clamp may be rolled in the seams.



- 1) In case of with the needle thread clamp, the standard of the length of needle thread is 40 to 50 mm.
- 2) When needle thread is long after replacing thread or the like or sewing while holding needle thread by hand, turn OFF the THREAD CLAMP key (  or  ).
- 3) When needle thread held with the needle thread clamp is rolled in the seams, when error has occurred, or when needle thread is held entangled with the needle thread clamp, do not forcibly draw the cloth, but cut the connected needle thread with scissors or the like. The seams cannot be broken because of the needle thread at the start of sewing.

(2) When the thread clamp is used, and bobbin thread at the sewing start appears on the right side of material, reduce thread tension at the sewing start (2 to 3 stitches) and bobbin thread becomes less conspicuous.

[Example of setting] Tension of 1 to 2 stitches at the sewing start is "20" when sewing tension setting is "35".

\* For setting of tension at the start of sewing, see of "**II-2-8.(1) Changing the thread tension value**" p.41.









1. Thread at the start of sewing may be rolled in case of some patterns. When thread is rolled in even after performing adjustment of (1) or (2), use the sewing machine with thread clamp OFF.
2. Thread clamp failure may occur in the state that thread waste is jammed in the thread clamp device. Remove the thread waste referring to "**III-1-6. Needle thread clamp device**" p.124.

## II .OPERATION SECTION (WITH REGARD TO THE PANEL)

### 1. PREFACE

\* 6 kinds of service patterns are contained in the media of the accessories.

Kind Area	EHS,EHL (Vinyl leather)	EHS,EHL (Denim)	ESS,ESL
1306 2206	ø 30 Pitch 3.6mm Pattern No. 61 	ø 30 Pitch 3 mm Pattern No. 62 	ø 30 Pitch 2.5 mm Pattern No. 63 
1510 2210	ø 60 Pitch 3.6mm Pattern No. 101 	ø 60 Pitch 3 mm Pattern No. 102 	ø 60 Pitch 2.5 mm Pattern No. 103 

#### 1) Kind of sewing data handled with IP-410 and the CP-20

Sewing data that each panel handles are as shown below.

Pattern name	Description	IP-410	CP-20
Users' pattern	Pattern that can be stored in the body. Max. 200 patterns can be registered.	○	○
Vector format data	File that extension is ".VDT" Read from media. Max. 999 patterns can be used.	○	○
M3 data	Pattern data of AMS-210D series Used by copying from floppy disk of AMS-210D series to media. Max. 999 patterns can be used.	○	×
Sewing standard format	File that extension is ".DAT" Read from media. Max. 999 patterns can be used.	○	×

#### 2) Using the data (M3 data) of AMS-210D series with AMS-210E

There are two ways to use M3 data with AMS-210E.

##### ① Reading by using IP-410

Use PC (personal computer) and copy file (¥AMS¥AMS00xxx.M3) of M3 from floppy disk of AMS-D to ¥AMS of media. Insert the media to IP-410, and select Pattern No.xxx from M3 data.

##### ② Changing to vector format data using PM-1

Change to the vector format data with PM-1. (For the details, refer to Help of PM-1.)

Copy the changed vector format data to ¥VDATA folder of the media.

Insert the media to IP-410 or CP-20 and select Pattern No.

### 3) Folder structure of the media

Store each file in the directories below of the media.

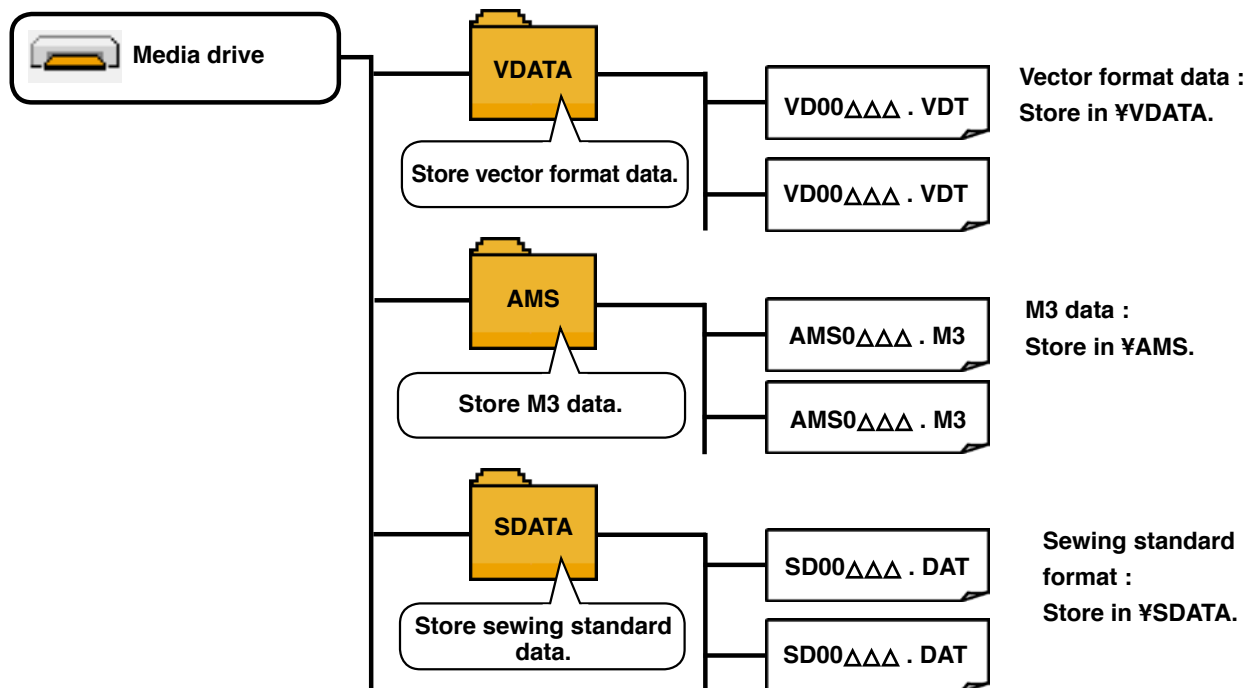

Data that are not stored in the directories above cannot be read. So, be careful.

### 4) Inserting direction of the media

[IP-410]

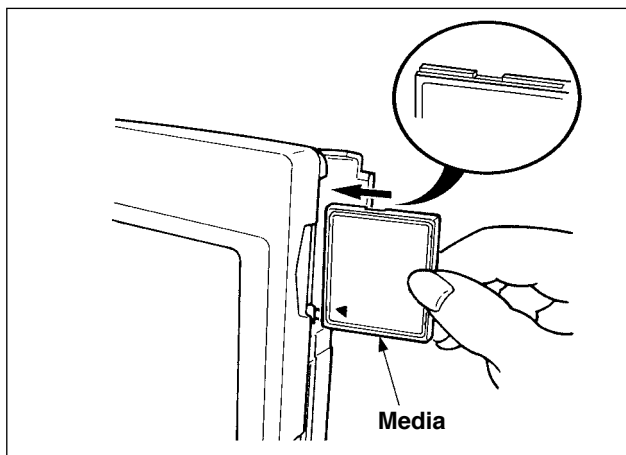

- ① Turn the label side of the CompactFlash(TM) to this side (place the notch of the edge to the rear. ) and insert the part that has a small hole into the panel.



1. When the inserting direction is wrong, panel or media may be damaged.
2. Do not insert any item other than the CompactFlash(TM).
3. IP-410 corresponds to the CompactFlash(TM) of 2GB or less.
4. IP-410 corresponds to the format FAT16 of CompactFlash(TM). It does not correspond to FAT32.
5. Be sure to use the CompactFlash(TM) which is formatted with IP-410. For the formatting procedure of the CompactFlash(TM), see " II-2-26. Performing formatting of the media", p.83.

- ② After completion of setting of the media, close the cover. By closing the cover, it is possible to access. If the media and the cover come in contact with each other and the cover is not closed, check the following matters.

- Check that the media is securely pressed until it goes no further.
- Check that the inserting direction of the media is proper.

[CP-20]

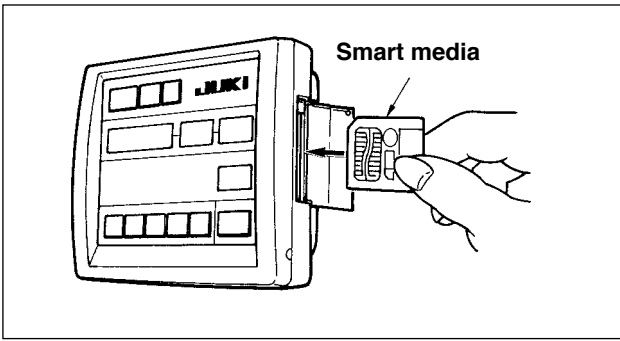

- ① Insert the smart media in the direction as shown in the figure.
- ② After completion of setting of the smart media, close the cover. By closing the cover, it is possible to perform communication. If the smart media and the cover come in contact with each other and the cover is not closed, check the following matters.

- Check that the inserting is stopped in the state that the smart media protrudes by approximately 10 mm.
- Check that the contact part is put downward and inserted.
- Check that the smart media other than 3.3 voltage type is used.



**Be sure to use the smart media that has been formatted with IP-400.**

**For the formatting procedure of the smart media, refer to "II-2-26. Performing formatting of the media" p.83.**

5) Removing procedure of the media

[IP-410]

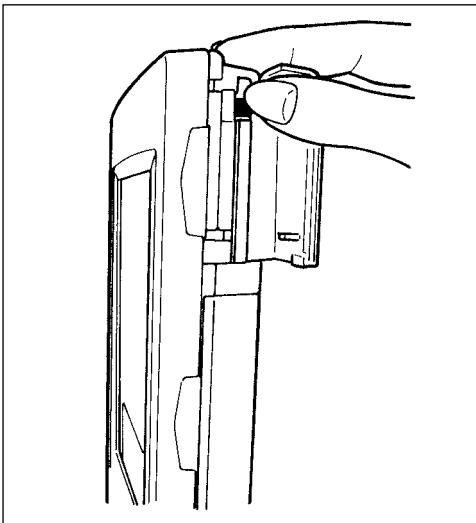

- ① Hold the panel by hand, open the cover, and press the media removing lever. The media is eject.



**When the lever is strongly pressed, the media may be broken by protruding and falling.**

- ② When the media is drawn out as it is, removing is completed.

[CP-20]

- ① Open the cover, push the smart media until it goes no further, and ease up force when it goes to the end. The smart media returns by approximately 10 mm in the reverse order of the time of setting.
- ② Then draw out the smart media to complete removing.

**Cautions when using the media**



- Do not wet or touch it with wet hands. Fire or electric shock will be caused.
- Do not bend, or apply strong force or shock to it.
- Never perform disassembling or remodeling of it.
- Do not put the metal to the contact part of it. Data may be disappeared.
- Avoid storing or using it in the places below.

Place of high temperature or humidity / Place of dew condensation /



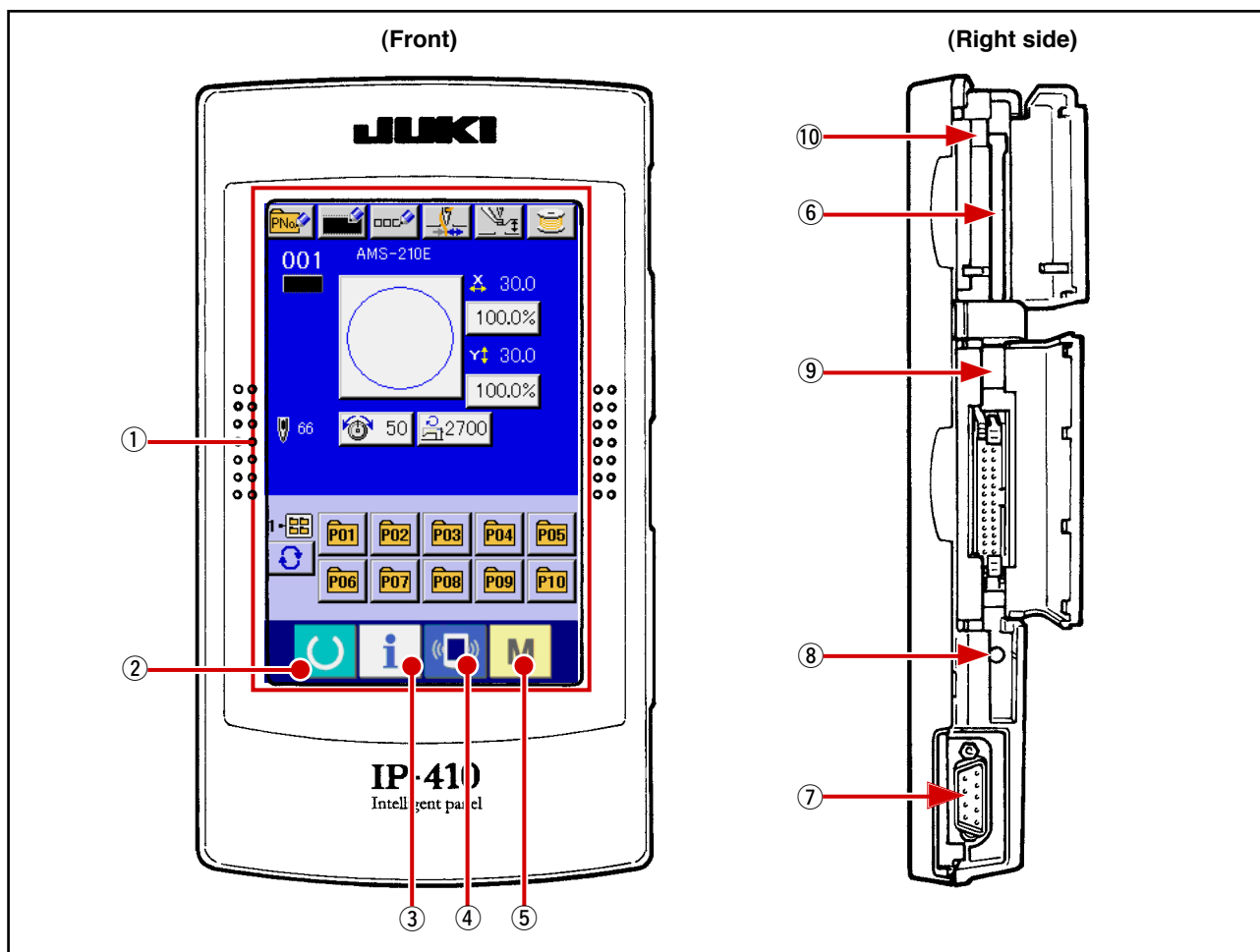

Place with much dust / Place where static electricity or electrical noise is likely to occur

## 2. WHEN USING IP-410

### 2-1. Name of each section of IP-410











① Touch panel · LCD display section

- ②  READY key → Changeover of the data input screen and the sewing screen can be performed.
- ③  INFORMATION key → Changeover of the data input screen and the information screen can be performed.
- ④  COMMUNICATION key → Changeover of the data input screen and the communication screen can be performed.
- ⑤  MODE key → Changeover of the data input screen and the mode changeover screen which performs various detail settings can be performed.
- ⑥ Media slot (Close the cover for use.)
- ⑦ Connector for RS-232C communication
- ⑧ Variable resistor for color LCD screen contrast adjustment
- ⑨ Connector for external input
- ⑩ Media removing lever



## 2-2. Buttons to be used in common

The buttons which perform common operations in each screen of IP-410 are as follows :

- |   |                        |  |
|---|------------------------|--|
|    | CANCEL button          | → This button closes the pop-up screen.<br>In case of the data change screen, the data being changed can be cancelled.                                   |
|    | ENTER button           | → This button determines the changed data.   |
|    | UP SCROLL button       | → This button scrolls the button or the display in the upward direction.   |
|    | DOWN SCROLL button     | → This button scrolls the button or the display in the downward direction.   |
|    | RESET button           | → This button performs the release of error.   |
|    | NUMERAL INPUT button   | → This button displays ten keys and input of numerals can be performed.  |
|    | CHARACTER INPUT button | → This button displays the character input screen.<br>→ Refer to “ <b>II-2-14. Naming users' pattern</b> ” p.51.   |
|   | RESSER LOWERING button | → Presser is lowered, and the presser lowering screen is displayed. To lift presser, press presser lift button displayed in the presser lowering screen. |
|  | Bobbin winder button   | → Bobbin thread winding is performed.<br>→ Refer to “ <b>II-2-11. Winding bobbin thread</b> ” p.46.  |



## 2-3. Basic operation of IP-410



### ① Turn ON the power switch

When the power is turned ON first, the language selection screen is displayed. Set the language you use. (It is possible to change with Memory switch U500.)



When ending the selection screen with CANCEL button  or ENTER button  without performing the language selection, the language selection screen is displayed whenever the power is turned ON.

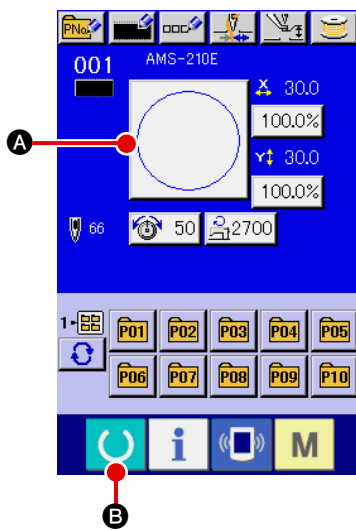

### ② Select the pattern No. you desire to sew.

When the power is turned ON, the data input screen is displayed. Pattern No. button **A** which is selected at present is displayed in the center of the screen. Press the button to select the sewing shape. For selecting procedure of the sewing shape, refer to "[II-2-5. Performing sewing shape selection](#)" p.36.

When READY key  **B** is pressed, the back color of LCD display is changed to green, and the sewing machine is set to the sewing possible state.

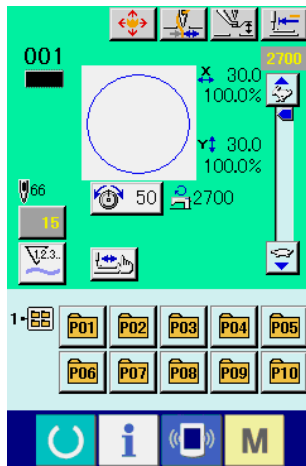

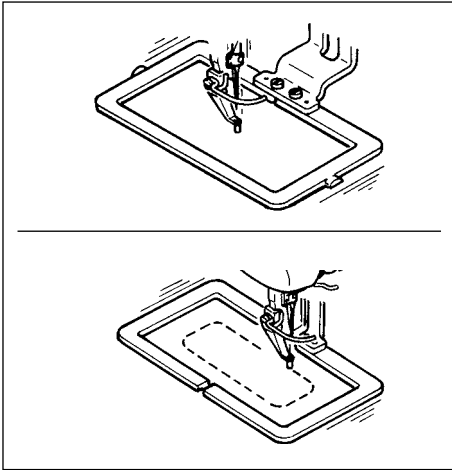

③ **Start sewing.**

Start sewing referring to " I -5-1. Sewing" p.22.

- \* For the screen, refer to " II -2-4. LCD display section at the time of sewing shape selection" p.32.









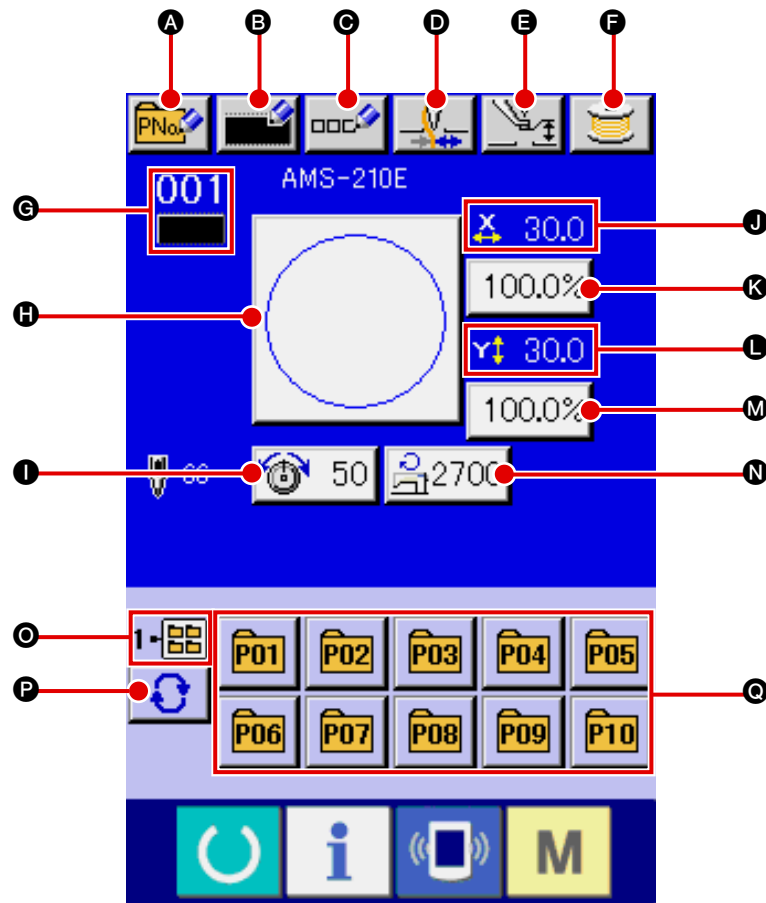



1. When using the exclusive presser, confirm the pattern shape for safety's sake. Should the pattern protrude from the feeding frame, needle interferes with the feeding frame during sewing, and there is a danger of needle breakage or the like.
2. When the presser is going up, be careful that your fingers are caught with the presser since the presser moves after coming down.
3. When turning OFF the power without pressing READY key  , the set value of "Pattern No.", "X enlargement/reduction ratio", "Y enlargement/reduction ratio", "Max. sewing speed", "Thread tension" or "Intermediate presser height" is not stored in memory.

## 2-4. LCD display section at the time of sewing shape selection

### (1) Sewing shape data input screen







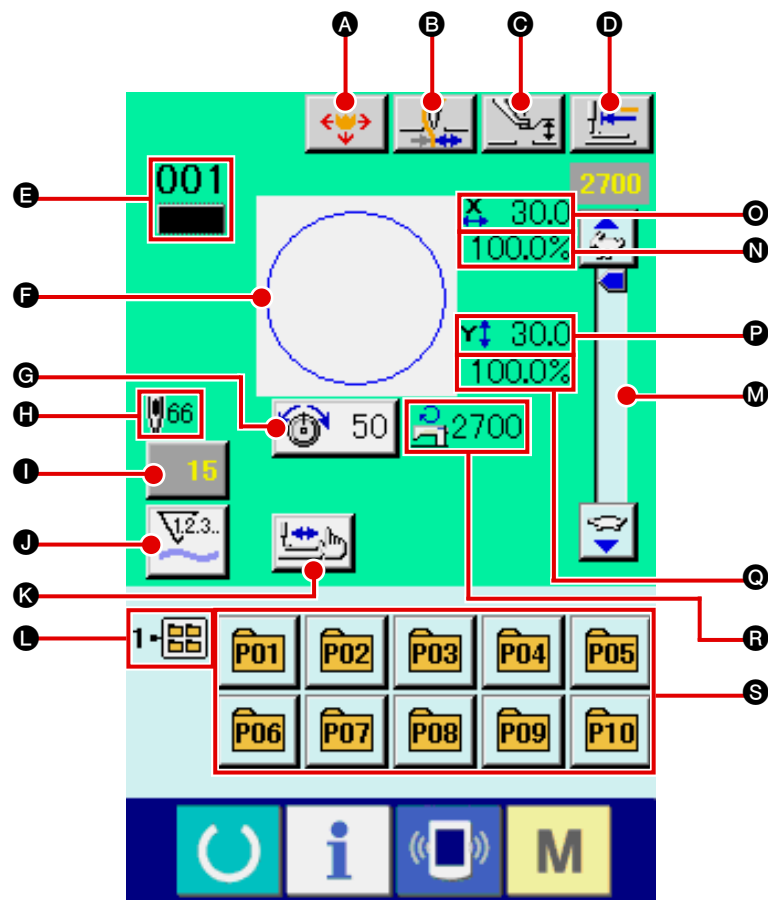

	Button and display	Description
A	PATTERN BUTTON NEW REGISTER button	Pattern button new register screen is displayed. → Refer to “ <a href="#">II-2-15. Performing new register of pattern button</a> ” p.52.
B	USERS' PATTERN NEW REGISTER button	Users' pattern new register screen is displayed. → Refer to “ <a href="#">II-2-13. Performing new register of users' pattern</a> ” p.50.
C	PATTERN BUTTON NAME SETTING button	Pattern button name input screen is displayed. → Refer to “ <a href="#">II-2-14. Naming users' pattern</a> ” p.51.
D	THREAD CLAMP button	Effective/ineffective of thread clamp is selected.  : Thread clamp ineffective  : Thread clamp effective
E	INTERMEDIATE PRESSER SETTING button	Intermediate presser is lowered and the intermediate presser reference value change screen is displayed. → Refer to “ <a href="#">II-2-6. Changing item data</a> ” p.38.
F	BOBBIN WINDER button	Bobbin thread can be wound. → Refer to “ <a href="#">II-2-11. Winding bobbin thread</a> ” p.46.

	Button and display	Description
Ⓒ	SEWING SHAPE NO. display	<p>Kind and No. of the sewing shape being selected at present is displayed. There are 4 kinds below of the kinds of sewing shape.</p> <p> : Users' pattern</p> <p> : Vector format data</p> <p> : M3 data</p> <p> : Sewing standard format</p> <p>* Be sure to use the media that has been formatted with IP-410. For the formatting procedure of the media, refer to "<b>II-2-26. Performing formatting of the media</b>" p.83.</p>
Ⓓ	SEWING SHAPE SELECTION button	<p>Sewing shape being selected at present is displayed on this button and when the button is pressed, the sewing shape selection screen is displayed.</p> <p>→ Refer to "<b>II-2-5. Performing sewing shape selection</b>". p.36</p>
Ⓔ	NEEDLE THREAD TENSION SETTING button	<p>Needle thread tension value which is set to the pattern data being selected at present is displayed on this button and when the button is pressed, the item data change screen is displayed.</p> <p>→ Refer to "<b>II-2-6. Changing item data</b>". p.38</p>
Ⓕ	X ACTUAL SIZE VALUE display	<p>Actual size value in X direction of sewing shape being selected at present is displayed.</p> <p>When the actual size value input is selected by setting memory switch  , X actual size value setting button is displayed.</p> <p>→ Refer to "<b>II-2-6. Changing item data</b>". p.38</p>
Ⓖ	X SCALE RATE SETTING button	<p>Scale rate in X direction of sewing shape being selected at present is displayed on this button.</p> <p>When the scale input is set to non-selection by setting memory switch  , the button goes out and the X scale is displayed.</p> <p>→ Refer to "<b>II-2-6. Changing item data</b>". p.38</p>
Ⓖ	Y ACTUAL SIZE VALUE display	<p>Actual size value in Y direction of sewing shape being selected at present is displayed.</p> <p>When the actual size value input is selected by setting memory switch  , Y actual size value setting button is displayed.</p> <p>→ Refer to "<b>II-2-6. Changing item data</b>". p.38</p>
Ⓜ	Y SCALE RATE SETTING button	<p>Scale rate in Y direction of sewing shape being selected at present is displayed on this button. When the scale input is set to non-selection by setting memory switch  , the button goes out and the Y scale is displayed. → Refer to "<b>II-2-6. Changing item data</b>". p.38</p>
Ⓝ	MAX. SPEED LIMITATION	<p>Maximum speed limitation which is set at present is displayed on this button and when the button is pressed, the item data change screen is displayed. (However, maximum speed limitation which is displayed is different from the maximum number of revolutions in the pattern.)</p> <p>→ Refer to "<b>II-2-6. Changing item data</b>". p.38</p>
Ⓒ	FOLDER NO. display	<p>Pattern register button which is displayed indicates the folder No. which has been stored.</p>
Ⓟ	FOLDER SELECTION button	<p>Folders to display the patterns are displayed in order.</p>
Ⓒ	PATTERN REGISTER button	<p>PATTERN REGISTER buttons stored in Ⓒ FOLDER NO display are displayed.</p> <p>→ Refer to "<b>II-2-15. Performing new register of pattern button</b>". p.52</p> <p>* This button is not displayed in the initial state.</p>

## (2) Sewing screen



	Button and display	Description
A	PATTERN MOVE button	Feeding frame is lowered and the pattern move screen is displayed. → Refer to “ <b>II -2-10. When setting of sewing product is difficult because of interruption of needle tip</b> ” p.45.
B	THREAD CLAMP button	Effective/ineffective of the thread clamp is selected.  : Thread clamp ineffective  : Thread clamp effective
C	INTERMEDIATE PRESSER SETTING button	Intermediate presser is lowered and the intermediate presser reference value change screen is displayed. → Refer to “ <b>II -2-6. Changing item data</b> ” p.38.
D	RETURN TO ORIGIN button	This button returns the presser to the start of sewing and raises the presser at the time of temporary stop.

	<b>Button and display</b>	<b>Description</b>
<b>E</b>	SEWING SHAPE NO. display	<p>Kind and No. of the sewing shape being selected at present is displayed. There are 4 kinds below of the kinds of sewing shape.</p> <div style="display: flex; flex-direction: column; align-items: center;"> <div style="display: flex; align-items: center; margin-bottom: 5px;">  : Users' pattern         </div> <div style="display: flex; align-items: center; margin-bottom: 5px;">  : Vector format data         </div> <div style="display: flex; align-items: center; margin-bottom: 5px;">  : M3 data         </div> <div style="display: flex; align-items: center;">  : Sewing standard format         </div> </div> <p>* Be sure to use the media that has been formatted with IP-410. For the formatting procedure of the media, refer to "<b>II-2-26. Performing formatting of the media</b>" p.83.</p>
<b>F</b>	SEWING SHAPE display	Sewing shape being selected at present is displayed.
<b>G</b>	NEEDLE THREAD TENSION SETTING button	<p>Needle thread tension value which is set to the pattern data being selected at present is displayed on this button and when the button is pressed, the item data change screen is displayed.</p> <p>→ Refer to "<b>II-2-6. Changing item data</b>" p.38.</p>
<b>H</b>	TOTAL NUMBER OF STITCHES OF SEWING SHAPE display	<p>Total number of stitches of the sewing shape being selected at present is displayed.</p> <p>* Displayed only when the sewing shape being selected is the standard pattern.</p>
<b>I</b>	COUNTER VALUE CHANGE button	<p>Existing counter value is displayed on this button.</p> <p>When the button is pressed, the counter value change screen is displayed.</p> <p>→ Refer to "<b>II-2-12. Using counter</b>" p.47.</p>
<b>J</b>	COUNTER CHANGE OVER button	<p>Display of sewing counter/No. of pcs. counter can be changed over.</p> <p>→ Refer to "<b>II-2-12. Using counter</b>" p.47.</p>
<b>K</b>	STEP SEWING button	<p>Step sewing screen is displayed. Checking of the pattern shape can be performed.</p> <p>→ Refer "<b>II-2-7. Checking pattern shape</b>" p.40.</p>
<b>L</b>	FOLDER NO. display	Pattern register button which is displayed indicates the folder No. which has been stored.
<b>M</b>	SPEED variable resistor	Number of rotations of the sewing machine can be changed.
<b>N</b>	X SCALE RATE display	Scale rate in X direction of sewing shape being selected is displayed.
<b>O</b>	X ACTUAL SIZE VALUE display	Actual size value in X direction of sewing shape being selected is displayed.
<b>P</b>	Y ACTUAL SIZE VALUE display	Actual size value in Y direction of sewing shape being selected is displayed.
<b>Q</b>	Y SCALE RATE display	Scale rate in Y direction of sewing shape being selected is displayed.
<b>R</b>	MAX. SPEED LIMITATION display	<p>Maximum speed limitation which is set at present is displayed. However, the display is different from the maximum number of revolutions in the pattern. However, the display is different from the maximum number of revolutions in the pattern.</p>
<b>S</b>	PATTERN REGISTER button	<p>Pattern register buttons stored in <b>L</b> FOLDER NO. display are displayed.</p> <p>→ Refer to "<b>II-2-15. Performing new register of pattern button</b>" p.52.</p> <p>* This button is not displayed in the initial state.</p>

## 2-5. Performing sewing shape selection

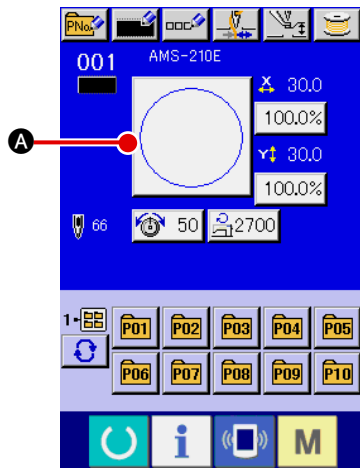

### ① Display the data input screen.

Only in case of the data input screen (blue), the selection of sewing shape can be performed. In case of the sewing screen (green), press READY key  and display the data input screen (blue).

### ② Call the sewing shape selection screen.

Press SEWING SHAPE button **A** and the sewing shape selection screen is displayed.

### ③ Select the sewing shape.

There are 4 kinds of the sewing shape.

Press SEWING SHAPE SELECTION button  **B**.

\* This button is not displayed in the initial state.

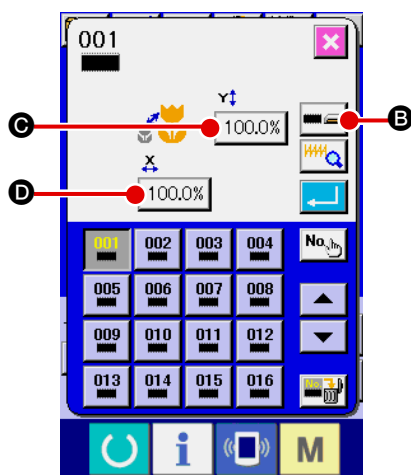



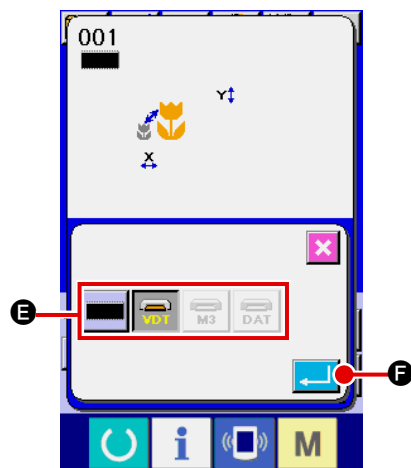

When button **C** or **D**  is pressed in this screen, X or Y enlarging/reducing ratio can be changed. For the details, refer to "II-2-6. Changing item data" p.38.

### ④ Determine the kind of sewing shape.

There are 4 kinds below of the sewing shape. Select the kind you desire from among them.



Pictograph	Name	Maximum number of patterns
	Users' pattern	200
	Vector format data	999
	M3 data	999
	Sewing standard format	999



**Be sure to use the media that has been formatted with IP-410.**

For the formatting procedure of the media, refer to

"II-2-26. Performing formatting of the media" p. 83.

Select the sewing shape you desire from SEWING SHAPE SELECTION buttons **E** and press ENTER

 **F** button.

The sewing shape list screen corresponding to the kind of sewing shape you selected is displayed.



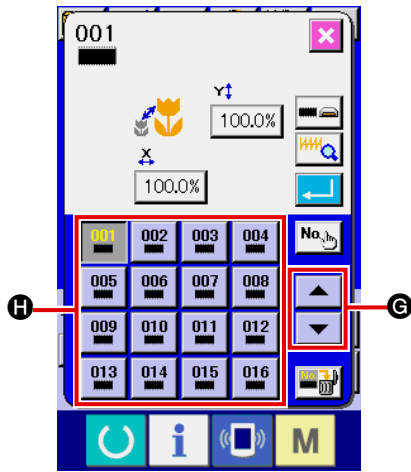

⑤ **Select the sewing shape.**

When UP or DOWN SCROLL button  **G** is pressed, the SEWING SHAPE buttons **H** are changed over in order. Here, press the SEWING SHAPE button you desire to select. The details of the selected shape is displayed at the upper part of the screen.

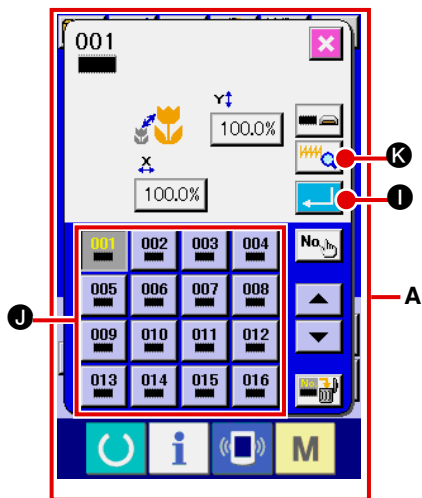



⑥ **Determine the sewing shape.**

When ENTER button  **I** is pressed, the sewing shape is determined and the data input screen is displayed.

When the sewing shape is users' pattern, the screen as **A** is displayed.

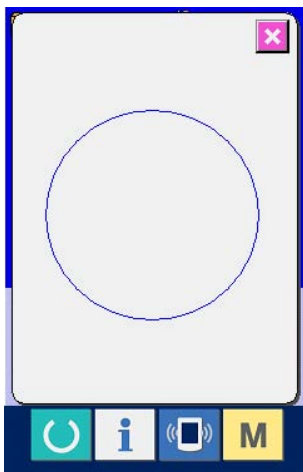
PATTERN NO. SELECTION button **J** that is registered to users' pattern is displayed. Press the button of PATTERN NO. you desire to select.



In addition, when you desire to confirm the selected shape, press VIEWER button  **K**, and the viewer screen is displayed to display the selected shape.

## 2-6. Changing item data

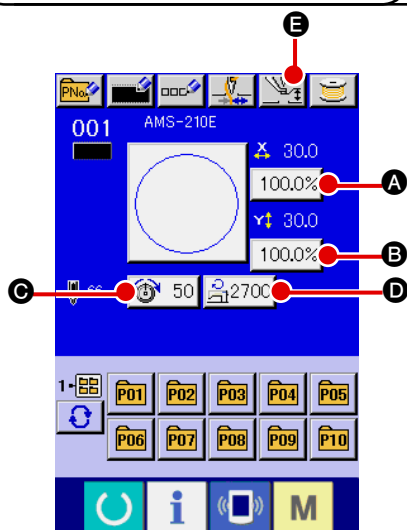

### ① Display the data input screen.

In case of the data input screen, the change of item data can be changed. In case of the sewing screen (green), press READY switch  to display the data input screen (blue).

\* Thread tension value can be changed even in the sewing screen.

### ② Display the item data input screen.

When the button of the item data you desire to change is pressed, the item data input screen is displayed.

Item data are 5 items below.

	Item range	Input range	Initial value
<b>A</b>	Scale rate in X direction	1.0 to 400.0 (%)	100.0 (%)
<b>B</b>	Scale rate in Y direction	1.0 to 400.0 (%)	100.0 (%)
<b>C</b>	Thread tension	0 to 200	Pattern set value
<b>D</b>	Max. speed limitation	400 to 2,700 (rpm)	2,700 (rpm)
<b>E</b>	Intermediate presser height	0.0 to 3.5 (mm) (Max 0.0 to 7.0 (mm))	Pattern set value

\* Thread tension value and intermediate presser reference value will change with every pattern to be selected.

\* **A** Scale rate in X direction and **B** Scale rate in Y direction can be changed to actual size value input by selection of the memory switch **U64**.

For enlargement and reduction, there are two ways. The data already read in can enlarge or reduce repeatedly with this button. When you desire to enlarge or reduce again from the original data, see "**II-2-5. Performing sewing shape selection**" p.36.

\* In case of the point sewing, even when increase/decrease of number of stitches is set under **U88** Enlargement and reduction function mode, enlargement and reduction can be performed with increase/decrease of pitch.

\* When X/Y scale rate is individually set in case of circle or arc, or X/Y enlargement and reduction are repeated, the sewing is changed to point sewing and the shape may not be kept. Enlargement and reduction can be performed by increase/decrease of pitch. In this case, set and read X/Y scale rate in the pattern list screen.

\* Max. input range and initial value of max. speed limitation **D** are determined with memory switch **U01**.

\* Change of the intermediate presser height cannot be performed immediately after turning ON the power. Use the machine after pressing READY key  and performing the origin retrieval.



**The setting exceeding 100% is dangerous since needle and the cloth presser interferes with each other and needle breakage or the like will occur.**

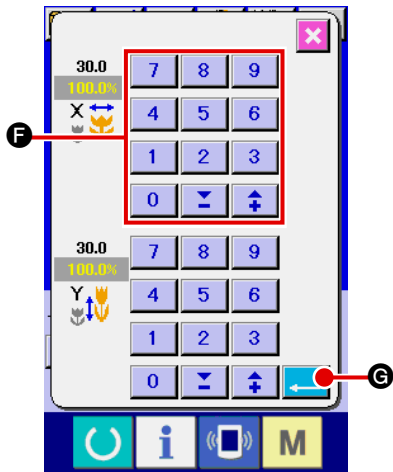

For example, input X scale rate.

Press  **A** to display the item data input screen.

③ **Input the data.**

Input the value you desire with ten keys and + / – keys **F**.

④ **Determine the data.**

When ENTER button  **G** is pressed, the data is determined.

\* For the other item data, the data can be changed by the same operation.

\* It is possible to input X/Y value of enlargement/reduction ratio and actual size value with one screen.



1. When turning OFF the power without pressing READY key , the set value of "Pattern No.", "X enlargement/reduction ratio", "Y enlargement/reduction ratio", "Max. sewing speed", "Thread tension" or "Intermediate presser height" is not stored in memory.
2. In case thread tension is changed in the read state, the set value when the power is turned OFF without pressing READY key or without performing sewing is not stored in memory.
3. When operation processing cannot be performed since the reduction ratio is excessively small, E045 Pattern data error is displayed.
4. When the scale rate is changed with increase/decrease of number of stitches (pitch is fixed), mechanical control command inputted to the points other than the shape point is deleted.

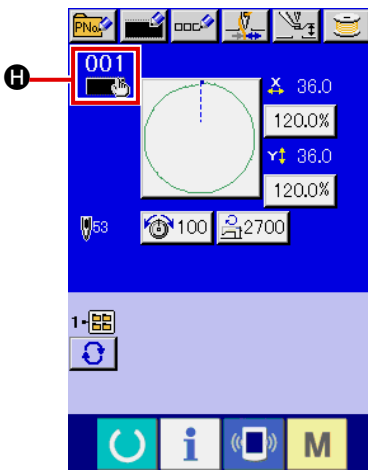

When X/Y enlargement/reduction ratio, thread tension, intermediate presser, adding/deleting of thread tension command, or adding/deleting of increase/decrease value of intermediate presser of users' pattern or media pattern is performed, the pattern kind section becomes change display **H**.

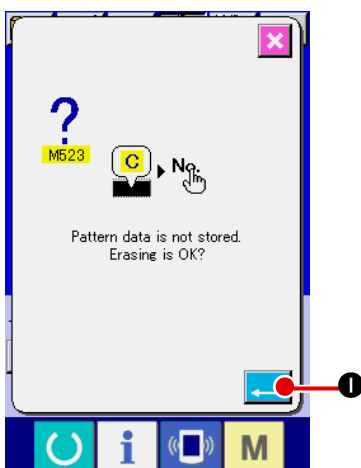

In case of change display **H**, the change confirmation screen is displayed at the time of the change of pattern.

When ENTER button  **I** is pressed, the information on the current pattern is invalidated and the pattern No. is changed.

To store the changed pattern, refer to “**II-2-13. Performing new register of users' pattern**” p.50.

## 2-7. Checking pattern shape



### WARNING :

Make sure without fail of the contour of the sewing pattern after selection of the sewing pattern. If the sewing pattern extends outside the work clamp feet, the needle will interfere with the work clamp.

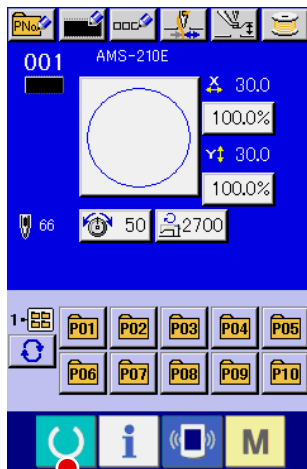

#### ① Display the sewing screen.

Display the data input screen (blue) and press READY key



**A**. Then the back-light of LCD changes to green and sewing is possible.

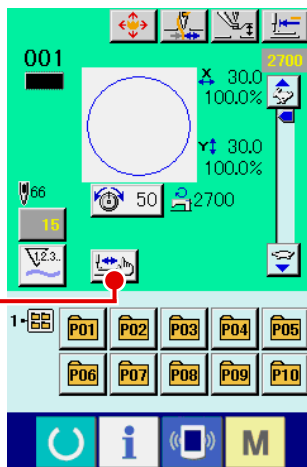

#### ② Display the step sewing screen.

When STEP SEWING button  **B** is pressed, the step sewing screen is displayed.



#### ③ Lower the presser with the foot switch.



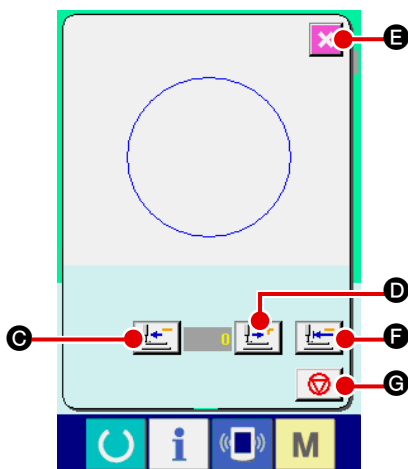

The sewing machine does not start even when the foot switch is depressed with this mode.



#### ④ Proceed stitching with the presser lowered.

Check the shape with PRESSER BACK button  **C** and PRESSER FORWARD button  **D**. When the button is held pressed for a fixed period of time, the presser continues to move even when the button is detached.

When you desire to stop, press STOP button  **G**.

When RETURN TO ORIGIN button  **F** is pressed, the presser moves to the origin.

#### ⑤ Finish checking the shape.

When CANCEL button  **E** is pressed, the screen returns to the sewing screen. When the checking of the shape is not in the position of the start of sewing or that of the end of sewing, press the foot switch. Then it is possible to sew from the midway of checking.



The presser does not come down immediately after turning ON the power.

## 2-8. Performing modification of needle entry point

Thread tension value and intermediate presser height of the needle entry point can be changed.

### (1) Changing the thread tension value

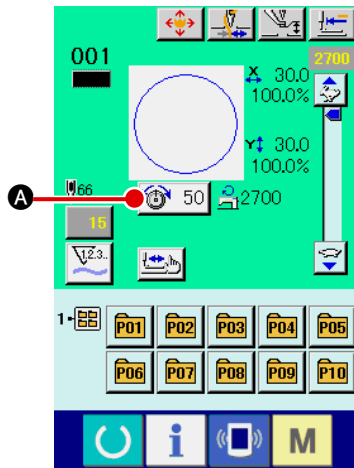

Press THREAD TENSION button  **A** in the sewing screen to display the thread tension setting screen.



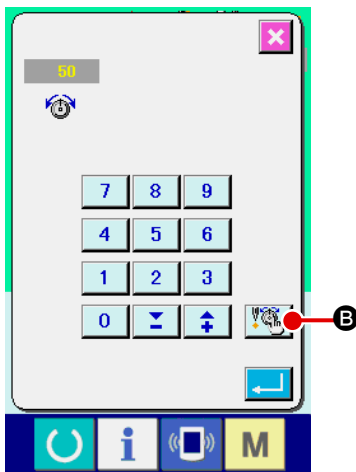

Press THREAD TENSION SELECTION button  **B** to display the thread tension command selection screen.



When  **C** is pressed, the thread tension value increase/decrease input screen is displayed.

With  **D** or  **E**, needle moves by one stitch in front or rear in the state that the presser is lowered.

With  **F** or  **G** the needle moves to the needle entry point where there is the thread tension command in the front or rear.

When you desire to stop, press STOP button  **H**.

When RETURN TO ORIGIN button  **I** is pressed, the presser moves to the origin.

The value which is displayed is the absolute value (thread tension value + thread tension command value).

Input the value you desire with TEN keys and +/- keys **J**.

When ENTER button  **K** is pressed, the data is determined.

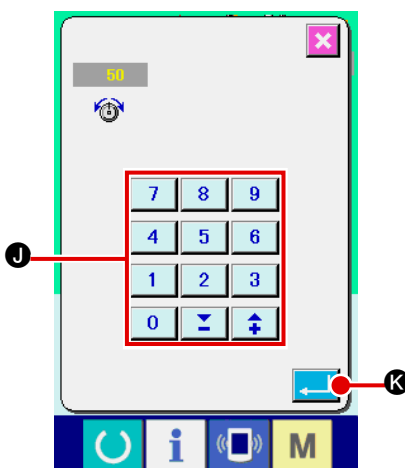
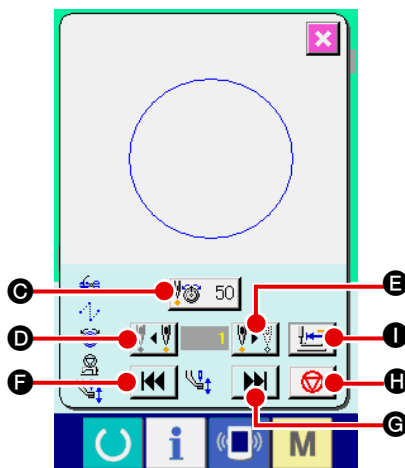

**When checking the needle, or performing the feed forward or backward, the machine fails to work unless the presser is lowered. Use the machine after lowering the presser.**

## (2) Changing the intermediate presser height value

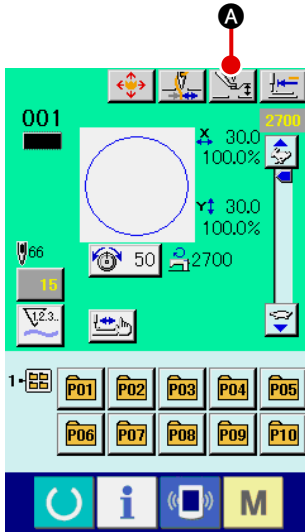

Press INTERMEDIATE PRESSER button  **A** in the sewing screen to display the intermediate presser foot height reference value setting screen.



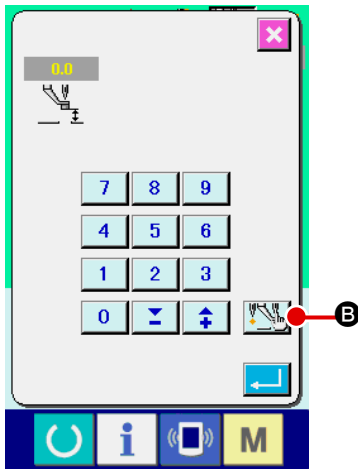

Press INTERMEDIATE PRESSER SELECTION button  **B** to display the intermediate presser height increase/decrease value selection screen.



When  **C** is pressed, the intermediate presser height increase/decrease value selection screen is displayed.

With  **D** or  **E**, needle moves by one stitch in front or rear in the state that the presser is lowered.

With  **F** or  **G**, needle moves to the needle entry point where there is the intermediate presser command in front or rear.

When you desire to stop, press STOP button  **H**.

When RETURN TO ORIGIN button  **I** is pressed, the presser moves to the origin. The value which is displayed is the absolute value (intermediate presser height value + intermediate presser increase/decrease value).

Input the value you desire with TEN keys and +/- keys **J**.

When ENTER button  **K** is pressed, the data is determined.

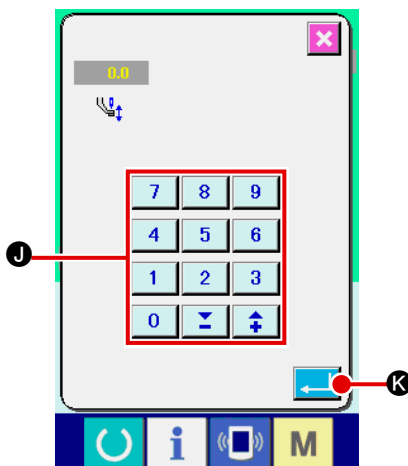
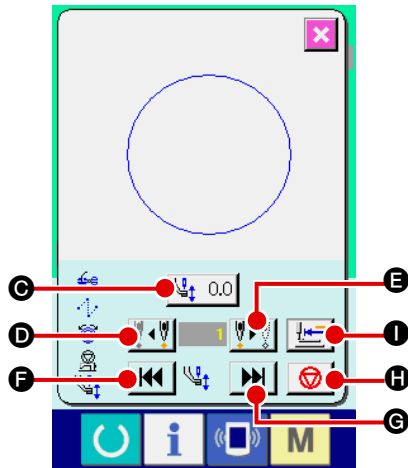

1. When checking the needle, or performing the feed forward or backward, the machine fails to work unless the presser is lowered. Use the machine after lowering the presser.
2. When increasing the height of intermediate presser or making the needle size thicker, confirm the clearance between the wiper and the components. Wiper cannot be used unless the clearance is secured. In this case, turn OFF the wiper switch, or change the set value of memory switch U105.



## 2-9. How to use temporary stop

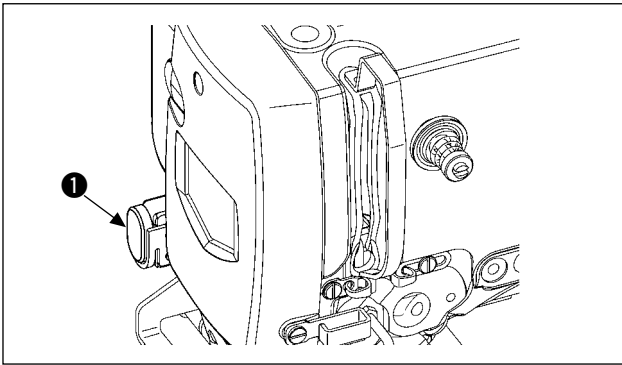

When TEMPORARY STOP switch ① is pressed during sewing, the sewing machine can be stopped. At this time, the error screen is displayed to inform that the stop switch has been pressed.

(1) To continue performing sewing from some point in sewing

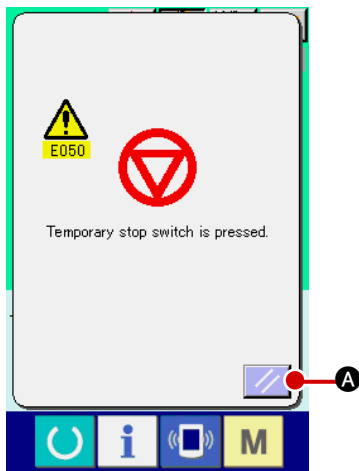





① **Release the error.**

Press RESET button  **A** to release the error.

② **Perform thread trimming.**

Press THREAD TRIM button  **B** to perform thread trimming.

When PRESSER UP button  **C** is pressed, the presser goes up. Turn OFF the power since the operation afterwards cannot be performed.

When thread trimming is performed, INTERMEDIATE PRESSER UP/DOWN button  **C**, FEED BACKWARD button  **D**, FEED FORWARD button  **E**, and RETURN TO ORIGIN button  **F** are displayed in the screen.

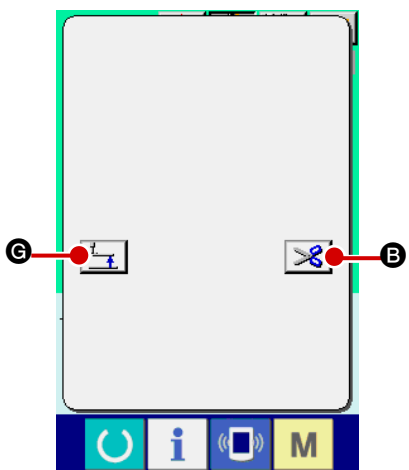

1. When the presser is raised and the operation is stopped on the way because of the trouble of forgetting to enter the bobbin case or the like, press

PRESSER UP button  **C** and turn OFF the power.

2. PRESSER UP button  **C** is not displayed when the presser is of pneumatic type.

③ **Adjust the presser to the re-sewing position.**

When FEED BACK button  **D** is pressed, the presser

returns stitch by stitch and when FEED FORWARD button  **E** is pressed, it advances stitch by stitch. Move the presser to the re-sewing position.

④ **Re-start the sewing**

When the pedal is depressed, sewing starts again.

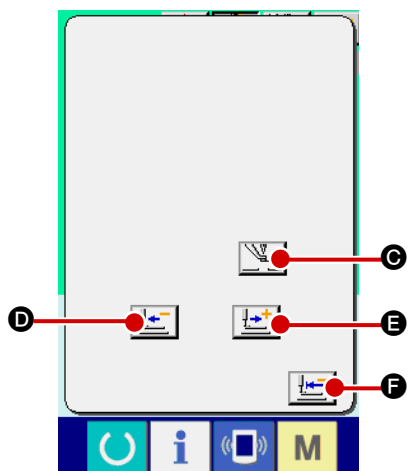

## (2) To perform re-sewing from the start

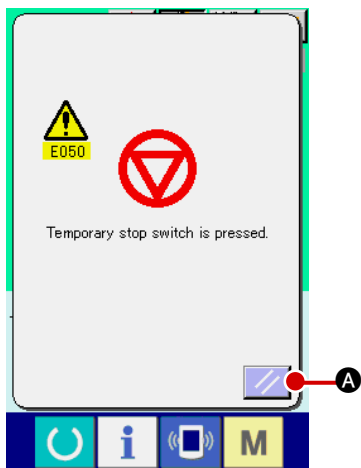

### ① Release the error.





Press RESET button  **A** to release the error.

### ② Perform thread trimming.

Press THREAD TRIM button  **B** to perform thread trimming.

When PRESSER UP button  **C** is pressed, the presser goes up. Turn OFF the power since the operation afterwards cannot be performed.

When thread trimming is performed, INTERMEDIATE

PRESSER UP/DOWN button  **C**, FEED BACKWARD button  **D**, FEED FORWARD button  **E**, and RETURN TO ORIGIN button  **F** are displayed in the screen.

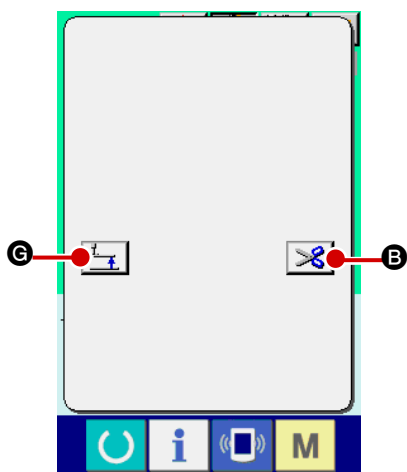

1. When the presser is raised and the operation is stopped on the way because of the trouble of forgetting to enter the bobbin case or the like, press



PRESSER UP button  **C** and turn OFF the power.

2. PRESSER UP button  **C** is not displayed when the presser is of pneumatic type.

### ③ Return to the origin.

When RETURN TO ORIGIN button  **F** is pressed, the pop-up is closed, the sewing screen is displayed and the machine returns to the position of the start of sewing.

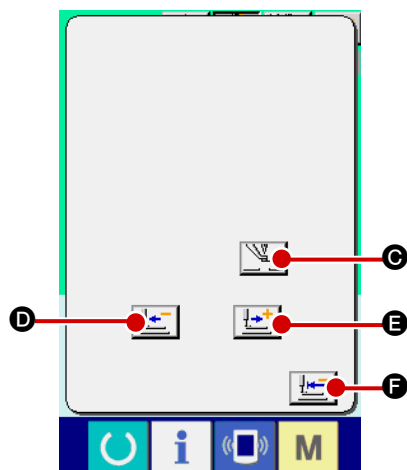

### ④ Perform again the sewing work from the start.

When the pedal is depressed, sewing starts again.



## 2-10. When setting of sewing product is difficult because of interruption of needle tip

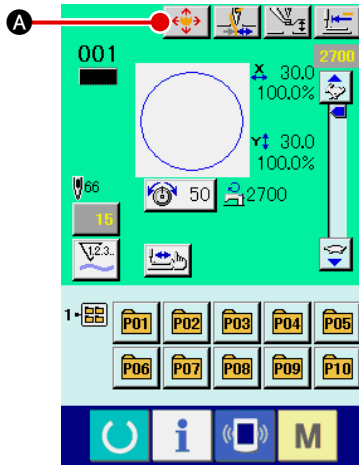

### ① Display the pattern button move screen.

When PATTERN BUTTON MOVE button  **A** is pressed, the pattern button move screen is displayed.

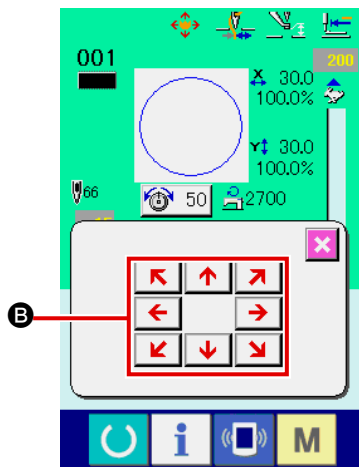

### ② Move the pattern.

Lower the presser, and input the move direction with DIRECTION key **B**.

## 2-11. Winding bobbin thread

### (1) When performing winding bobbin thread while performing sewing

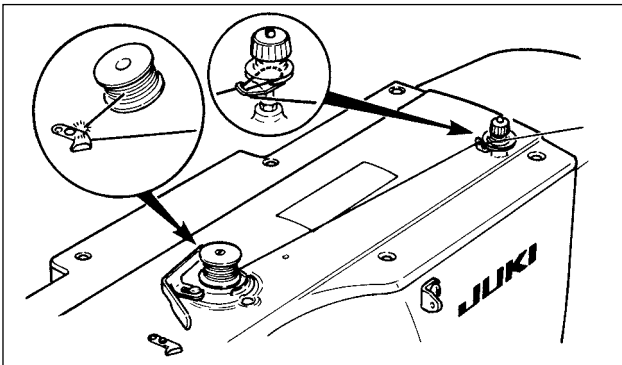

Thread the bobbin winder and wind the bobbin thread onto the bobbin as illustrated in the figure.

### (2) When performing winding bobbin thread only

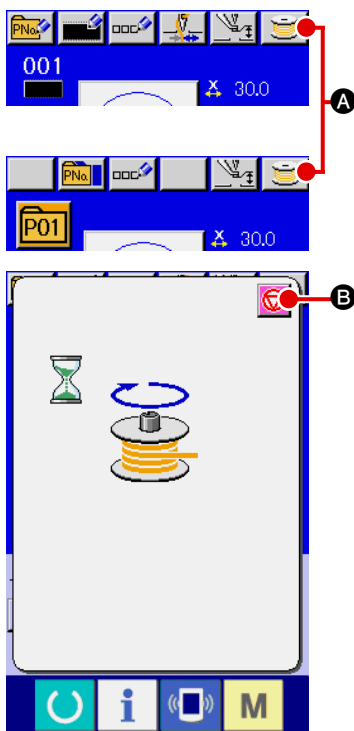

#### ① Display the bobbin winding screen.

Press BOBBIN WINDER button  **A** in the data input screen (blue) and the bobbin winding screen is displayed.

#### ② Start bobbin winding.

Depress the start pedal, and the sewing machine rotates and starts winding bobbin thread.

#### ③ Stop the sewing machine.

Press STOP button  **B** and the sewing machine stops and returns to the normal mode. Or, depress the start pedal again during winding bobbin and the sewing machine stops while the bobbin thread winding mode stays as it is. Depress the start pedal again and the bobbin winding starts again. Use this way when winding bobbin thread around plural bobbins.



Bobbin winder does not work immediately after turning ON the power. Perform the bobbin winding after setting pattern No. or the like once, pressing the READY key , and making the sewing LED light up.

## 2-12. Using counter

### (1) Setting procedure of the counter

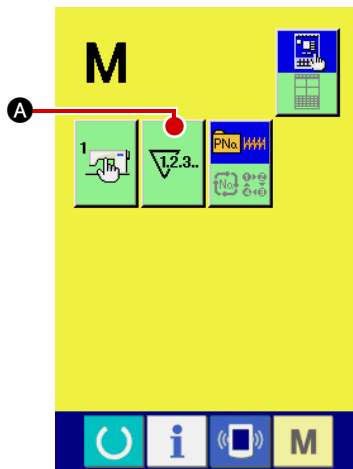

#### ① Display the counter setting screen.

Press **M** switch and the COUNTER SETTING button .

**A** is displayed on the screen. When this button is pressed, the counter setting screen is displayed.

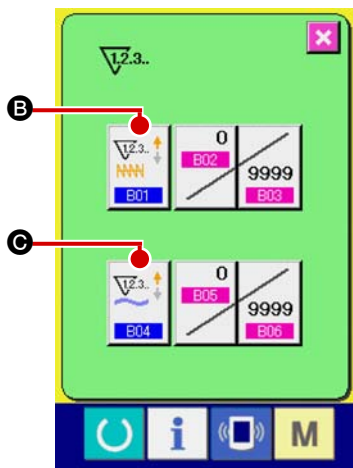

#### ② Selection of kinds of counters

This sewing machine has two kinds of counters, i. e. , sewing counter and No. of pcs. counter. Press SEWING COUNTER

KIND SELECTION button  **B** or NO. OF PCS. KIND SE-

LECTION button  **C** to display the counter kind selection screen. The kinds of the respective counters can be set separately.

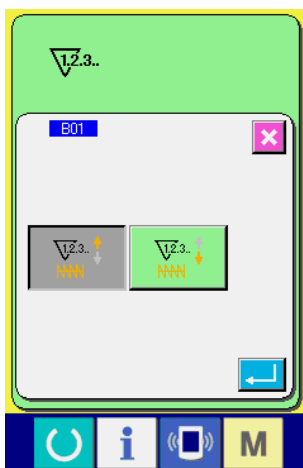

#### [ Sewing counter ]



##### UP counter :

Every time the sewing of one shape is performed, the existing value is counted up. When the existing value is equal to the set value, the count-up screen is displayed.



##### DOWN counter :

Every time the sewing of one shape is performed, the existing value is counted down. When the existing value is reached to "0", the count-up screen is displayed.

#### [ No. of pcs. Counter ]



##### UP counter :

Every time one combination sewing is performed, the existing value is counted up. When the existing value is equal to the set value, the count-up screen is displayed.



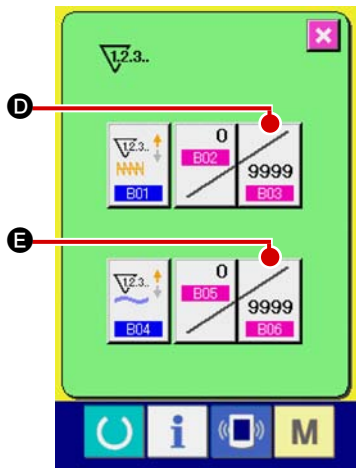

##### DOWN counter :

Every time one combination sewing is performed, the existing value is counted down. When the existing value is reached to "0", the count-up screen is displayed.



③ **Change of counter set value**

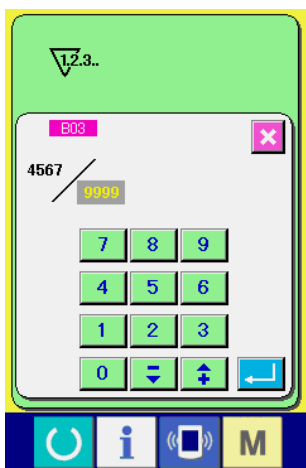

In case of the sewing counter, press button  **D** and in case of the No. of pcs. counter, press button  **E** and the set value input screen is displayed.

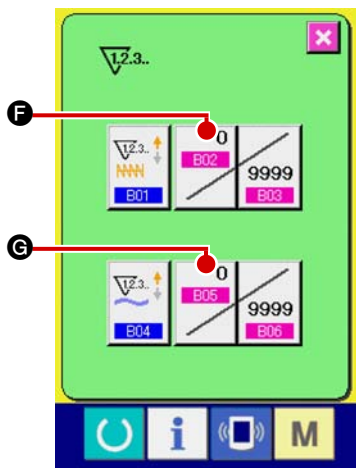

Here, input the set value.  
When "0" is inputted in the set value, the display of count-up screen is not performed.



④ **Change of counter existing value**

In case of the sewing counter, press button  **F** and in case of the No. of pcs. counter, press button  **G** and the existing value input screen is displayed.

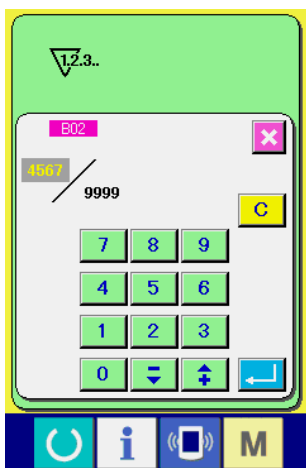

Here, input the existing value.

## (2) Count-up releasing procedure

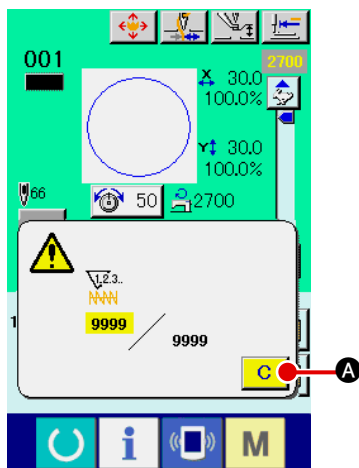

When the count-up condition is reached during sewing work, the count-up screen is displayed and the buzzer beeps. Press CLEAR button **C** **A** to reset the counter and the screen returns to the sewing screen. Then the counter starts counting again.

## (3) How to change the counter value during sewing

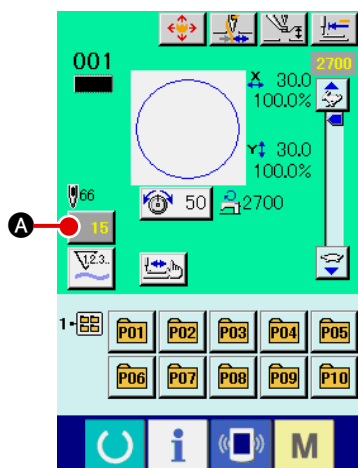

### ① Display the counter value change screen.

When you desire to revise the counter value during sewing work due to the mistake or the like, press COUNTER VALUE CHANGE button **15** **A** on the sewing screen. The counter value change screen is displayed.

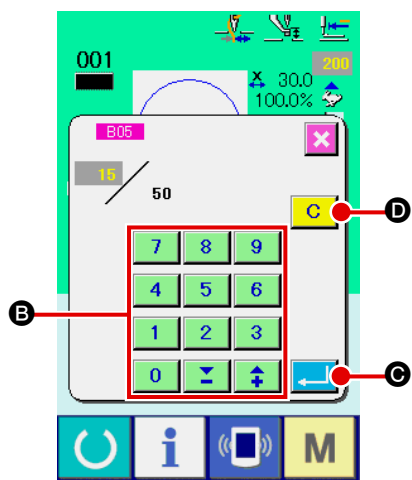

### ② Change the counter value.

Input the value you desire with ten keys, or “+” or “-” key **B**.

### ③ Determine the counter value.

When ENTER button **C** is pressed, the data is determined.

When you desire to clear the counter value, press CLEAR button **C** **D**.

## 2-13. Performing new register of users' pattern

### ① Display the data input screen.

Only in case of the data input screen (blue), new register of the pattern can be performed. In case of the sewing screen (green), press READY switch  and display the data input screen (blue).

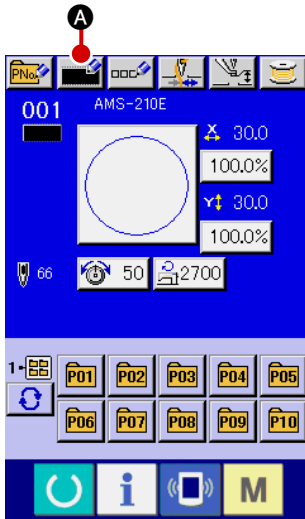

### ② Call the new register of users' pattern screen.

Press NEW REGISTER button  (A) and the new register of users' pattern screen is displayed.

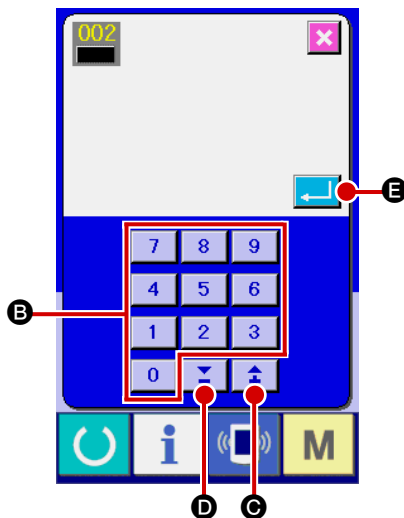

### ③ Input the users' pattern No.

Input the users' pattern No. you desire to newly register with the ten keys (B). It is possible to retrieve the users' pattern No. which has not been registered with the + or – button  (C and D).

### ④ Determine the users' pattern No.

Press ENTER button  (E) to determine the users' pattern NO. to be newly registered and the data input screen at the time of users' pattern selection is displayed. When the existing users' pattern No. is inputted and ENTER button is pressed, the overwriting confirmation screen is displayed.

## 2-14. Naming users' pattern

As many as 14 characters can be inputted in each users' pattern.

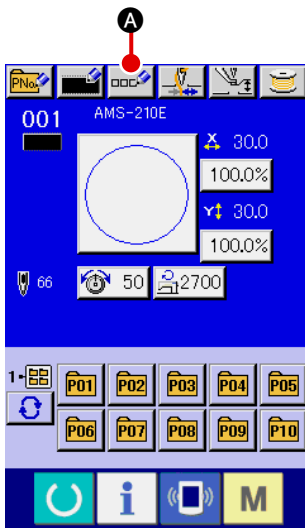

### ① Display the data input screen.

Only in case of the data input screen (blue) at the time of pattern button selection, it is possible to input the name of pattern button. In case of the sewing screen (green), press READY switch  to display the data input screen (blue).

### ② Call the character input screen.

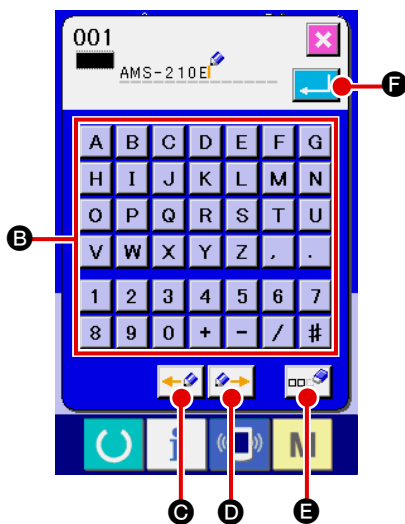

When CHARACTER INPUT button  **A** is pressed, the character input screen is displayed.



### ③ Input the character.

Press CHARACTER button **B** you desire to input and the input of character can be performed.

As many as 14 characters of characters ( **A** to **Z** and **0** to **9** ) and symbols ( **+** , **-** , **/** , **#** , **.** and **.** ) can be inputted. The cursor can be moved with CURSOR LEFT

TRAVEL button  **C** and CURSOR RIGHT TRAVEL button  **D**. When you desire to delete the inputted character, adjust the cursor to the position of the character you desire to delete and press DELETE button  **E**.

### ④ Finish the input of character.

When ENTER button  **F** is pressed, the input of character is finished. After the finish, the inputted character is displayed on the upper part of the data input screen (blue).

## 2-15. Performing new register of pattern button

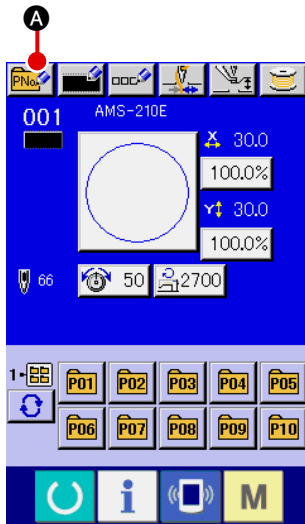

### ① Display the data input screen.

Only in case of the data input screen (blue), new register of the pattern button can be performed. In case of the sewing screen (green), press READY switch  and display the data input screen (blue).

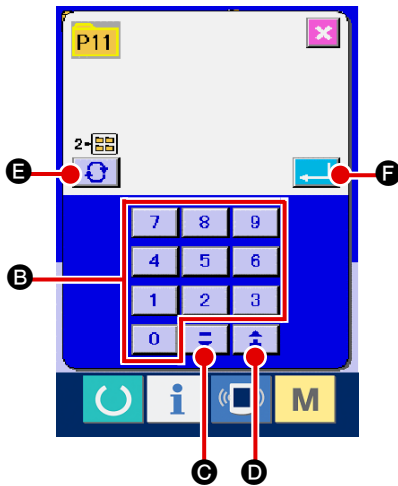

### ② Call the new register of pattern button screen.

Press NEW REGISTER button  **A** and the new register of pattern button screen is displayed.



### ③ Input the pattern button No.

Input the pattern button No. you desire to newly register with the ten keys **B**. New register to the pattern button No. which has been already registered is prohibited.

It is possible to retrieve the pattern button No. which has not been registered with the “+” or “-” button   (**C** and **D**).

### ④ Select the folder to be stored.

It is possible for the pattern buttons to be stored in five folders. As many as 10 pattern buttons can be stored for one folder.

The folder to store the button can be selected with FOLDER SELECTION button  **E**.

### ⑤ Determine the pattern No.

Press ENTER button  **F** to determine the pattern button No. to be newly registered and the data input screen at the time of pattern button selection is displayed.



**Caution** Press P1 to P50 key while the sewing screen is displayed or the sewing LED lights up and the presser comes down. Be careful that your fingers are not caught in the presser.





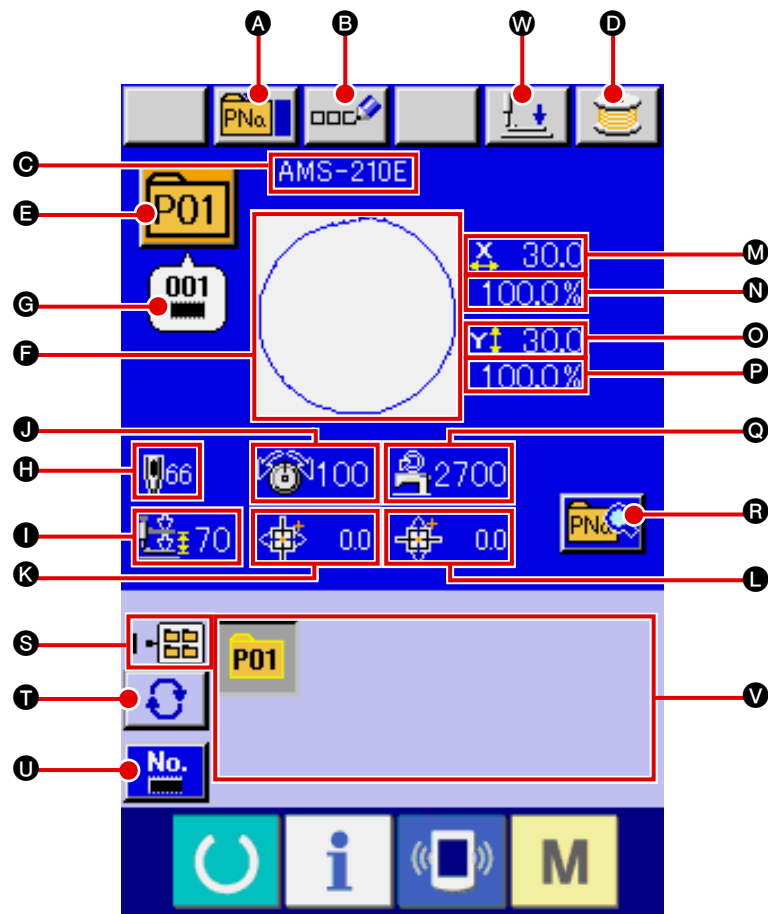

## 2-16. LCD display section at the time of pattern button selection

### (1) Pattern button data input screen





	Button and display	Description
A	PATTERN BUTTON COPY button	Pattern button copy screen is displayed. → Refer to “ <b>II-2-19. Copying pattern button</b> ” p.60.
B	PATTERN BUTTON NAME SETTING button	Pattern button name input screen is displayed. → Refer to “ <b>II-2-14. Naming users’ pattern</b> ” p.51.
C	PATTERN BUTTON NAME display	Character which is registered to the pattern button No. being selected is displayed.
D	WINDING BOBBIN button	Bobbin thread can be wound. → Refer to “ <b>II-2-11. Winding bobbin thread</b> ” p.46.
E	PATTERN BUTTON NO. display	Pattern button No. being selected at present is displayed on this button and when the button is pressed, the pattern button No. selection screen is displayed. → Refer to “ <b>II-2-17. Performing pattern button No. selection</b> ” p.57.
F	SEWING SHAPE	Sewing shape which is registered to the pattern button No. being selected is displayed.

	Button and display	Description
Ⓒ	SEWING SHAPE NO.	<p>Sewing shape which is registered to the pattern button No. being selected is displayed. There are 4 kinds below of the kinds of sewing shape.</p> <p> : Users' pattern</p> <p> : Vector format data</p> <p> : M3 data</p> <p> : Sewing standard format</p> <p>* Be sure to use the media that has been formatted with IP-410. For the formatting procedure of the media, refer to <b>" II -2-26. Performing formatting of the media" p.83.</b></p>
Ⓓ	TOTAL NO. OF STITCHES	<p>Total number of stitches of the pattern which is registered to the pattern button No. being selected is displayed.</p> <p>* This item is displayed only when the sewing shape being selected is the standard pattern.</p>
Ⓔ	2-STEP STROKE display	2-step stroke value registered to the pattern button No. being selected is displayed.
Ⓕ	THREAD TENSION display	Thread tension value which is registered to the pattern button No. being selected is displayed.
Ⓖ	TRAVEL AMOUNT IN X DIRECTION display	Travel amount in X direction which is registered to the pattern button No. being selected is displayed.
Ⓗ	TRAVEL AMOUNT IN Y DIRECTION display	Travel amount in Y direction which is registered to the pattern button No. being selected is displayed.
Ⓜ	X ACTUAL SIZE VALUE display	X actual size value which is registered to the pattern button No. being selected is displayed.
Ⓝ	X SCALE RATE display	X scale rate which is registered to the pattern button No. being selected is displayed.
Ⓒ	Y ACTUAL SIZE VALUE display	Y actual size value which is registered to the pattern button No. being selected is displayed.
Ⓟ	Y SCALE RATE display	Y scale rate which is registered to the pattern button No. being selected is displayed.
Ⓒ	MAX. SPEED LIMITATION	Maximum speed limitation which is registered to the pattern button No. being selected is displayed.
Ⓡ	PATTERN BUTTON EDIT button	Pattern button edit screen is displayed.
Ⓢ	FOLDER NO. display	Folder No. in which the displayed pattern buttons are stored is displayed.
Ⓣ	FOLDER SELECTION button	Folders to display the pattern button are displayed in order.
Ⓤ	SEWING SHAPE SELECTION DATA INPUT SCREEN DISPLAY button	<p>Sewing shape data input screen is displayed.</p> <p>→ Refer to <b>" II -2-4.(1) Sewing shape data input screen" p.32.</b></p>
Ⓥ	PATTERN button	<p>Pattern buttons stored in Ⓢ Folder No. are displayed.</p> <p>→ Refer to <b>" II -2-15. Performing new register of pattern button" p.52.</b></p>
Ⓦ	PRESSER DOWN button	<p>Presser can be lowered and the presser down screen is displayed.</p> <p>To raise the presser, press the presser up button which is displayed in the presser down screen.</p>

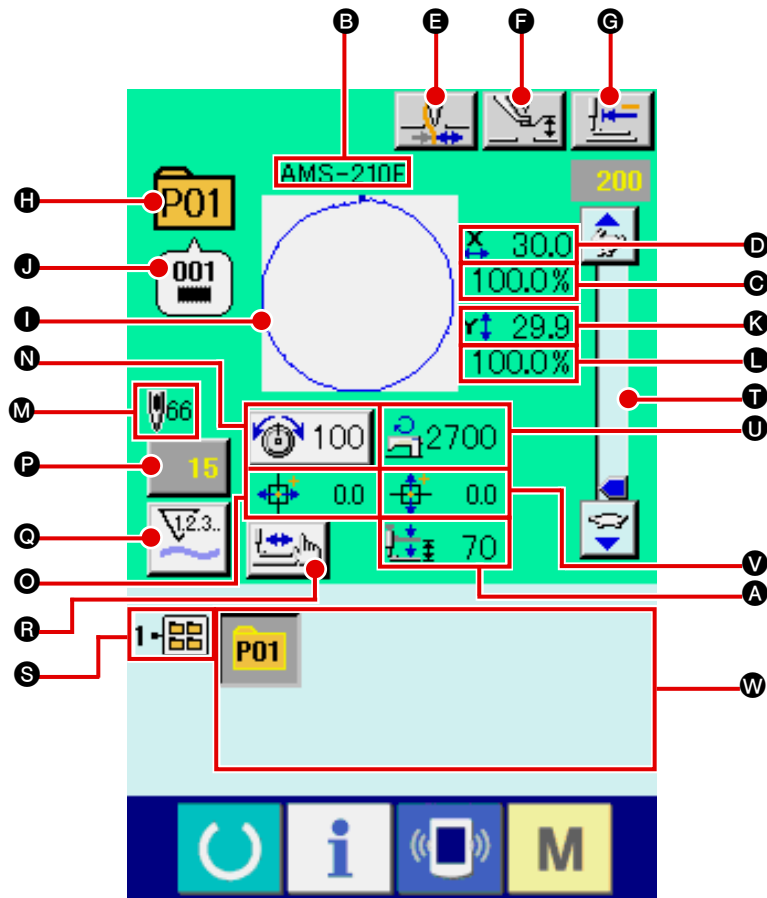
## (2) Sewing screen



	Button and display	Description
<b>A</b>	2-STEP STROKE display	2-step stroke value registered to the pattern button No. during sewing is displayed.
<b>B</b>	PATTERN BUTTON NAME display	Character which is registered to the pattern button No. being sewn is displayed.
<b>C</b>	X SCALE RATE display	Scale rate in X direction which is registered to the pattern button No. being sewn is displayed.
<b>D</b>	X ACTUAL SIZE VALUE display	Actual size value in X direction which is registered to the pattern button No. being sewn is displayed.
<b>E</b>	THREAD CLAMP button	Effective/ineffective of thread clamp is selected.  : Thread clamp ineffective  : Thread clamp effective

	Button and display	Description
F	PRESSER DOWN button	Presser can be lowered and the presser down screen is displayed. To raise the presser, press the presser up button displayed in the presser down screen.
G	RETURN TO ORIGIN button	Presser is returned to the start of sewing and is raised at the time of temporary stop.
H	PATTERN NO. display	Pattern button No. being sewn is displayed.
I	SEWING SHAPE display	Sewing shape being sewn is displayed.
J	SEWING SHAPE NO. display	Kind of sewing and sewing shape No. which are registered to the pattern being sewn are displayed.
K	Y ACTUAL SIZE VALUE display	Actual size value in Y direction which is registered to the pattern button No. being sewn is displayed.
L	Y SCALE RATE display	Scale rate in Y direction which is registered to the pattern button No. being sewn is displayed.
M	TOTAL NO. OF STITCHES OF SEWING SHAPE display	Total number of stitches of sewing shape which is registered to the pattern button No. being sewn is displayed.
N	NEEDLE THREAD TENSION SETTING button	Needle thread tension value which is set to the pattern data being selected at present is displayed on this button and when the button is pressed, the item data change screen is displayed. → Refer to “ <b>II-2-6. Changing item data</b> ” p.38.
O	TRAVEL AMOUNT IN X DIRECTION display	Travel amount in X direction which is registered to the pattern button No. being sewn is displayed.
P	COUNTER VALUE CHANGE button	Existing counter value is displayed on this button. When the button is pressed, the counter value change screen is displayed. → Refer to “ <b>II-2-12. Using counter</b> ” p.47.
Q	COUNTER CHANGEOVER button	Display of sewing counter/No. of pcs. counter can be changed over. → Refer to “ <b>II-2-12. Using counter</b> ” p.47.
R	STEP SEWING button	The step sewing screen is displayed. Checking the pattern shape can be performed. → Refer to “ <b>II-2-7. Checking pattern shape</b> ” p.40.
S	FOLDER NO. display	Folder No. in which the displayed pattern register buttons are stored is displayed.
T	SPEED variable resistor	Number of revolutions of the sewing machine can be changed.
U	MAX. SPEED LIMITATION display	Maximum speed limitation which is registered to the pattern button No. being sewn is displayed.
V	TRAVEL AMOUNT IN Y DIRECTION display	Travel amount in Y direction which is registered to the pattern button No. being sewn is displayed.
W	PATTERN REGISTER button	Pattern button which is stored in S FOLDER NO. is displayed. → Refer to “ <b>II-2-15. Performing new register of pattern button</b> ” p.52.

## 2-17. Performing pattern button No. selection

### (1) Selection from the data input screen

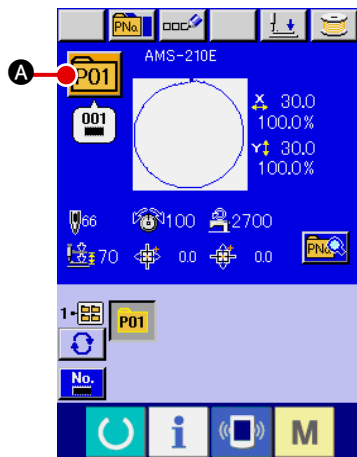

#### ① Display the data input screen.

In case of the data input screen (blue), it is possible to select the pattern button No. In case of the sewing screen (green), press READY switch  to display the data input screen.

#### ② Call the pattern button No. selection screen.

When PATTERN BUTTON NO. SELECTION button  **A** is pressed, the pattern button No. selection screen is displayed. Pattern button No. which is selected at present and the contents are displayed on the upper part of the screen, and the list of the pattern button No. buttons which have been registered is displayed on the lower part of the screen.

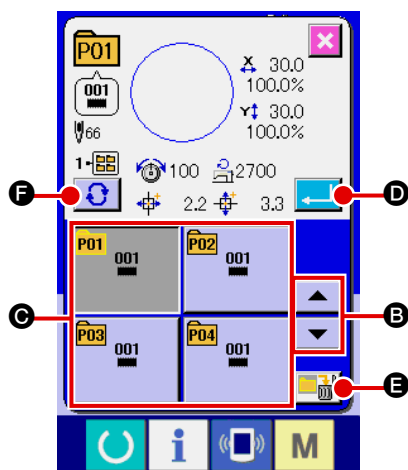



#### ③ Select the pattern button No.

When UP or DOWN SCROLL button  **B** is pressed, pattern button No. buttons **C** which have been registered are changed over in order. The contents of sewing data which have been inputted in the pattern button No. are displayed in the button. Here, press the pattern button No. button **C** you desire to select.

#### ④ Determine the pattern button No.

When ENTER button  **D** is pressed, the pattern button No. selection screen is closed and the selection is finished. However, the pattern buttons which are registered to the combination sewing cannot be deleted.

\* When you desire to delete the pattern button which has been registered, press DELETE  **E** button. However, the pattern buttons which are registered to the combination sewing cannot be deleted.

\* For the pattern No. to be displayed, press FOLDER SELECTION  **F** button and pattern button Nos. which have been stored in the specified folder are displayed in the list. When the folder No. is not displayed, all pattern Nos. which have been registered are displayed.

## (2) Selection by means of the shortcut button



### WARNING :

Make sure without fail of the contour of the sewing pattern after selection of the sewing pattern. If the sewing pattern extends outside the work clamp feet, the needle will interfere with the work clamp.

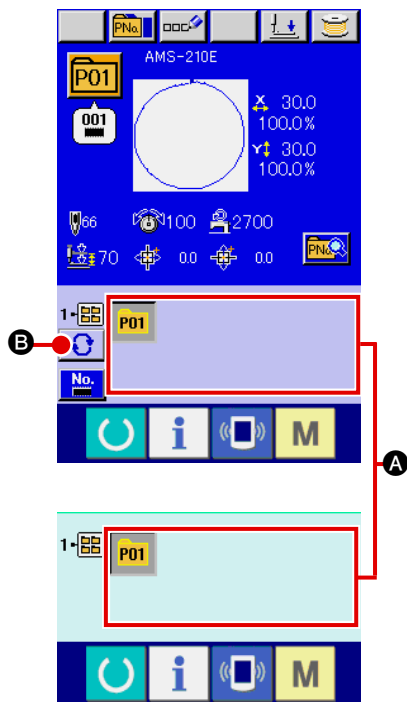

### ① Display the data input screen or the sewing screen.

When the pattern is registered to the folder, pattern buttons **A** are surely displayed on the lower side of the screen of the data input screen or sewing screen.

### ② Select the pattern No.

Pattern button is displayed with every folder which is specified when the pattern is newly created.

When FOLDER SELECTION button  **B** is pressed, the pattern button to be displayed is changed. Display and press the button of the pattern button No. you desire to sew. When it is pressed, the pattern button No. is selected.

## 2-18. Changing contents of pattern button

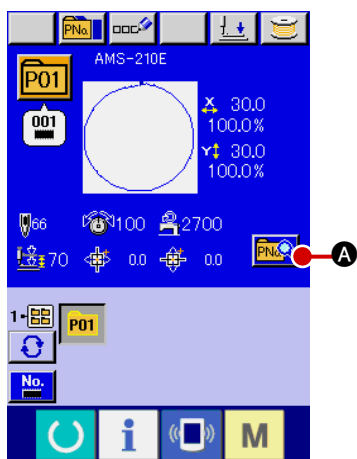

### ① Display the data input screen at the time of pattern button selection.

Only in case of the data input screen (blue) at the time of pattern selection, it is possible to change the contents of pattern. In case of the sewing screen (green), press READY switch  to display the data input screen at the time of pattern button selection.

### ② Display the pattern button data change screen.

When PATTERN BUTTON DATA CHANGE button  **A** is pressed, the pattern button data change screen is displayed.

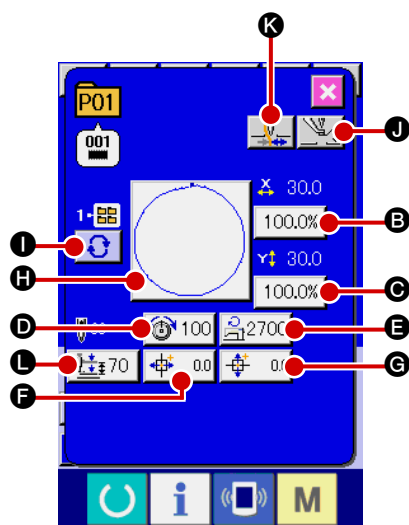

### ③ Display the input screen of the item data you desire to change.

Data that can be changed are 11 items below.

	Item	Input range	Initial value
<b>B</b>	Scale rate in X direction	1.0 to 400.0(%)	100.0
<b>C</b>	Scale rate in Y direction	1.0 to 400.0(%)	100.0
<b>D</b>	Thread tension	0 to 200	Pattern set value
<b>E</b>	Max. speed limitation	400 to 2700(rpm)	2700
<b>F</b>	Travel amount in X direction	1306 : -66.0 to +66.0 (mm) 1510 : -76.0 to +76.0(mm) 2206 : -111.0 to +111.0(mm) 2210 : -111.0 to +111.0(mm)	0.0
<b>G</b>	Travel amount in Y direction	1306 : -33.0 to +33.0(mm) 1510 : -51.0 to +51.0(mm) 2206 : -33.0 to +33.0(mm) 2210 : -51.0 to +51.0(mm)	0.0
<b>H</b>	Sewing shape	-	-
<b>I</b>	Folder No.	1 to 5	-
<b>J</b>	Intermediate presser	0.0 to 3.5 (mm) (Max. 0.0 to 7.0 (mm))	Pattern set value
<b>K</b>	Thread clamp	With/without	With
<b>L</b>	2-step stroke height	50 to 90	70

When pressing each button of **B** through **H** and **J**, the item data input screen is displayed. When the buttons of **I** and **K** are pressed, Folder Nos. and With/without thread clamp are changed over.

- \* Thread tension value and intermediate presser reference value will change with every pattern to be selected.
- \* **B** Scale rate in X direction and **C** Scale rate in Y direction can be changed to the actual size value input by selection of memory switch **U64**.
- \* Max. input range and initial value of max. speed limitation **D** are determined with memory switch **U01**.
- \* The input range of travel amount in X direction **F** and travel amount in Y direction **G** differs according to the sewing range.

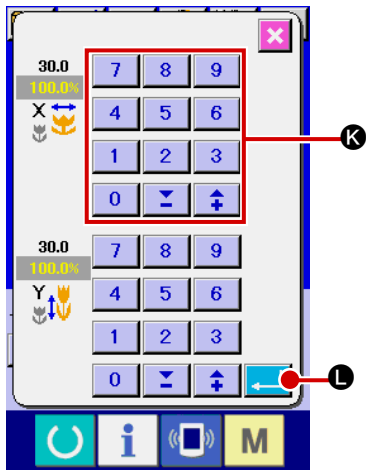

④ **Determine the change of item data**

For example, input X scale rate. Press **100.0%** **B** to display the item data input screen. Input the value you desire with the ten keys or + or – key **K**. When ENTER button **L** is pressed, the data is determined.

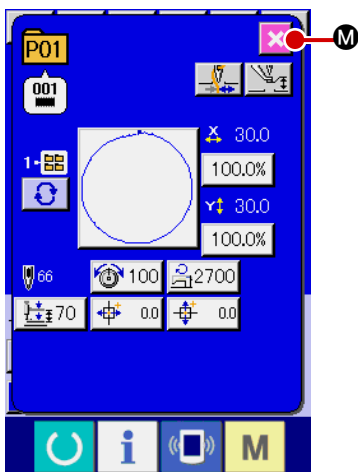

⑤ **Close the pattern button data change screen.**

When the change is over, press CLOSE button **M**. The pattern button data change screen is closed and the screen returns to the data input screen.

\* It can be performed to change the other item data by the same operation.

**Important** In case thread tension is changed in the read state, the set value when the power is turned OFF without pressing READY key **C** or without performing sewing is not stored in memory.

## 2-19. Copying pattern button

The sewing data of the pattern button No. which has already been registered can be copied to the pattern button No. which is not registered. Overwriting copy of the pattern button is prohibited. When you desire to overwrite, perform it after deleting the pattern button once.

→ Refer to “**II-2-17. Performing pattern button No. selection**” p.57.

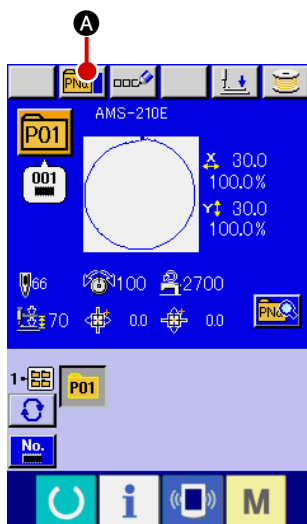

① **Display the data input screen.**

Only in case of the data input screen (blue) at the time of pattern button selection, it is possible to copy. In case of the sewing screen (green), press READY switch **C** to display the data input screen (blue).

② **Call the pattern copy screen.**

When PATTERN BUTTON COPY button **PNo.** **A** is pressed, the pattern button copy (copy source selection) screen is displayed.



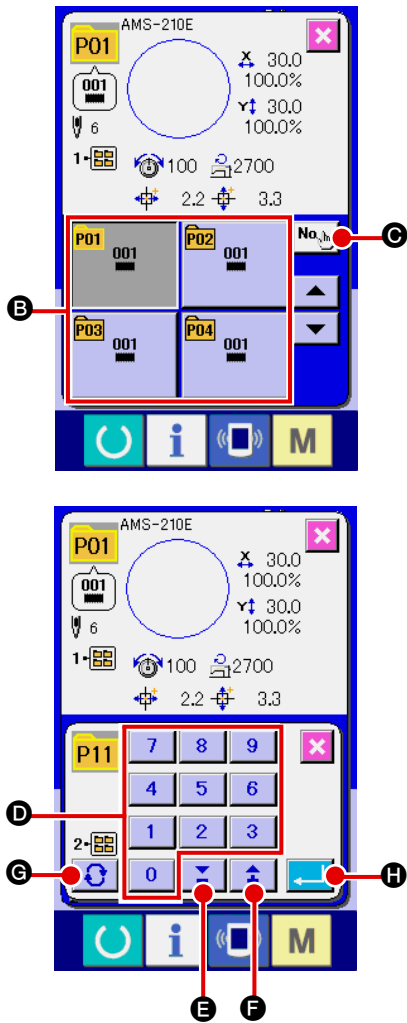

③ **Select the pattern No. of copy source.**

Select the pattern button No. of copy source from the pattern button list button **B**.

Next, press COPY DESTINATION INPUT button  **C** and the copy destination input screen is displayed.

④ **Input the pattern No. of copy destination.**

Input the pattern button No. of copy destination with ten keys **D**. Pattern button No. which is not used yet can be retrieved with

– and + buttons   (**E** and **F**).

In addition, the folder to be stored can be selected with FOLDER SELECTION button  **G**.

⑤ **Start copying.**

When ENTER button  **H** is pressed, copying starts. The copied pattern button No. in the selection state returns to the pattern button copy (copy source selection) screen after approximately two seconds.

\* Combination data can be copied in the same way.

## 2-20. Changing sewing mode

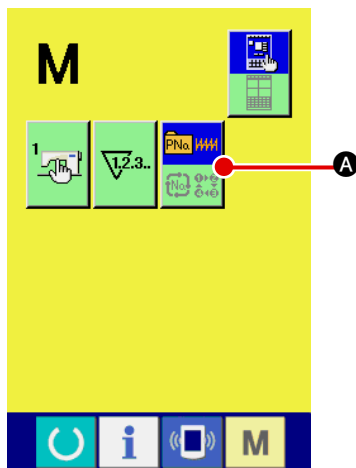

① **Select the sewing mode.**

When **M** switch is pressed in the state that the pattern has

been registered, SEWING MODE SELECTION button  **A**

is displayed on the screen. When this button is pressed, the sewing mode changes alternately the individual sewing and the combination sewing. (The mode cannot be changed even when the button is pressed unless the pattern button is registered.)

\* The image of the button of sewing mode selection button changes according to the sewing mode which is selected at present.

When individual sewing is selected :



When combination sewing is selected :



## 2-21. LCD display section at the time of combination sewing

The sewing machine is capable of sewing in order by combining the plural pattern data. As many as 30 patterns can be inputted. Use this function when sewing plural different shapes on the sewing product. In addition, it is possible to register as many as 20 of the combination sewing data. Use this function for new creation and copying in case of need.

- Refer to “**II-2-15. Performing new register of pattern button**” p.52 and “**II-2-19. Copying pattern button**” p.60.

### (1) Pattern input screen

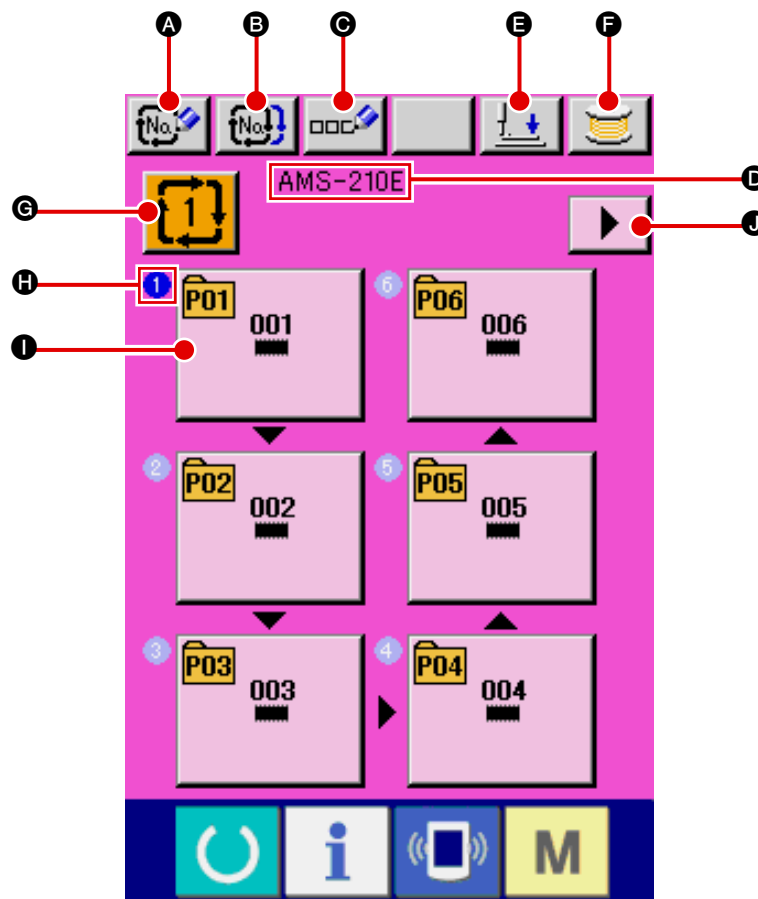



	Button and display	Description
A	COMBINATION DATA NEW REGISTER button	Combination data No. new register screen is displayed. → Refer to “ <b>II-2-15. Performing new register of pattern button</b> ” p.52.
B	COMBINATION DATA COPY button	Combination pattern No. copy screen is displayed. → Refer to “ <b>II-2-19. Copying pattern button</b> ” p.60.
C	COMBINATION DATA NAME INPUT button	Combination data name input screen is displayed. → Refer to “ <b>II-2-14. Naming users’ pattern</b> ” p.51
D	COMBINATION DATA NAME display	Name which is inputted in the combination data being selected is displayed.
E	PRESSER DOWN button	Presser can be lowered and the presser down screen is displayed. To raise the presser, press the presser up button displayed in the presser down screen.
F	BOBBIN WINDING	Bobbin thread can be wound. → Refer to “ <b>II-2-11. Winding bobbin thread</b> ” p.46.

	<b>Button and display</b>	<b>Description</b>
	<b>Ⓒ</b> COMBINATION DATA NO. SELECTION button	Combination data No. being selected is displayed in the button. When the button is pressed, the combination data No. selection screen is displayed.
	<b>Ⓗ</b> SEWING ORDER display	Sewing order of the inputted pattern data is displayed. When the screen is changed over to the sewing screen, the pattern which is sewn first is displayed in blue color.
	<b>Ⓘ</b> PATTERN SELECTION button	Pattern No., shape, number of stitches, etc. which are registered in <b>Ⓗ</b> SEWING ORDER are displayed on the button. When the button is pressed, the pattern selection screen is displayed.
	<b>Ⓙ</b> NEXT PAGE DISPLAY button	When the patterns which are registered to the combination data become more than 6 pcs. , this button is displayed. It is possible to register the patterns from the 7th to the next page. As many as 5 pages can be displayed

\* As many as the number of inputted patterns is displayed in **Ⓗ** and **Ⓘ**, display and button.

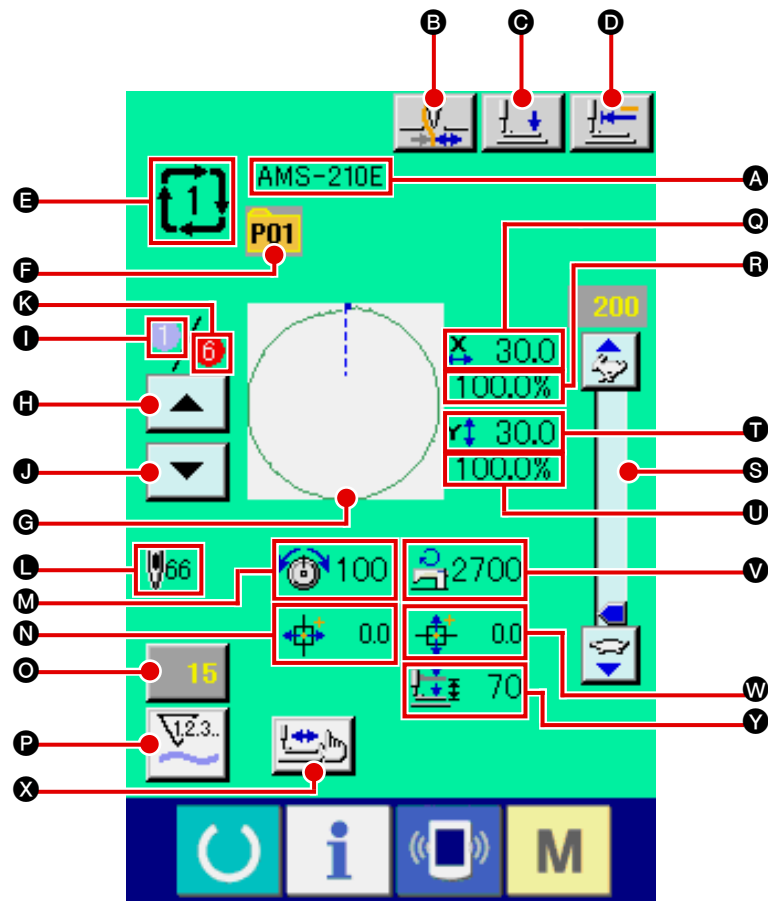
## (2) Sewing screen



	Button and display	Description
A	COMBINATION DATA NAME display	Name which is inputted in the combination data being selected is displayed.
B	THREAD CLAMP button	Effective/ineffective of thread clamp is selected.  : Thread clamp ineffective  : Thread clamp effective
C	PRESSER DOWN button	Presser can be lowered and the presser down screen is displayed. To raise the presser, press the presser up button displayed in the presser down screen.
D	RETURN TO ORIGIN button	Presser can be returned to the start of sewing and is raised at the time of temporary stop.
E	COMBINATION DATA NO. display	Combination data No. being selected is displayed.
F	PATTERN BUTTON NO. display	Pattern button No. being sewn is displayed.
G	SEWING SHAPE display	Sewing shape which is registered to pattern button No. being sewn is displayed.
H	SEWING ORDER RETURN button	Pattern to be sewn can be returned by one.
I	SEWING ORDER display	Sewing order being sewn at present is displayed.

	<b>Button and display</b>	<b>Description</b>
ⓙ	SEWING ORDER ADVANCE button	Pattern to be sewn can be advanced by one.
Ⓚ	TOTAL NUMBER OF REGISTERS display	Total number of patterns which is registered to combination No. being sewn is displayed.
Ⓛ	TOTAL NUMBER OF STITCHES display	Total number of stitches of sewing shape being sewn is displayed.
Ⓜ	THREAD TENSION display	Thread tension value which is registered to pattern button No. being sewn is displayed.
Ⓝ	TRAVEL AMOUNT IN X DIRECTION display	Travel amount in X direction which is registered to the pattern button No. being sewn is displayed.
Ⓞ	COUNTER VALUE CHANGE button	Existing counter value is displayed on this button. When the button is pressed, the counter value change screen is displayed. → Refer to “ <b>II-2-12. Using counter</b> ” p.47.
Ⓟ	COUNTER CHANGEOVER button	Display of sewing counter/No. of pcs. counter can be changed over. → Refer to “ <b>II-2-12. Using counter</b> ” p.47.
Ⓠ	X ACTUAL SIZE AMOUNT display	X actual size value of the sewing shape which is registered to pattern button No. being sewn is displayed.
Ⓡ	X SCALE RATE display	X scale rate of the sewing shape which is registered to pattern button No. being sewn is displayed.
Ⓢ	SPEED variable resistor	Number of revolutions of the sewing machine can be changed.
Ⓣ	Y ACTUAL SIZE VALUE display	Y actual size value of the sewing shape which is registered to pattern button No. being sewn is displayed.
Ⓤ	Y SCALE RATE display	Y scale rate of the sewing shape which is registered to pattern button No. being sewn is displayed.
Ⓥ	MAX. SPEED LIMITATION display	Maximum speed limitation which is registered to pattern button No. being sewn is displayed.
Ⓦ	TRAVEL AMOUNT IN Y DIRECTION display	Travel amount in Y direction which is registered to the pattern button No. being sewn is displayed.
Ⓧ	STEP SEWING button	The step sewing screen is displayed. Checking the pattern shape can be performed. → Refer to “ <b>II-2-7. Checking pattern shape</b> ” p.40.
Ⓨ	2-STEP STROKE display	2-step stroke value registered to the pattern button No. during sewing is displayed.

## 2-22. Performing combination sewing

First, change the sewing mode to the combination sewing before performing setting.

→ Refer to “II-2-20. Changing sewing mode” p.61.

### (1) Selection of combination data

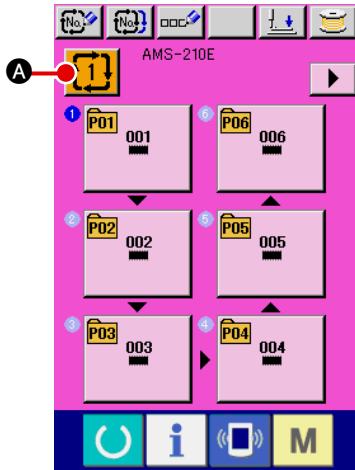

#### ① Display the data input screen.

Only in case of the data input screen (pink), it is possible to select the combination data No.

In case of the sewing screen (green), press READY switch



to display the data input screen (pink).

#### ② Call the combination data No. screen.

When COMBINATION DATA NO. button  **A** is pressed, the combination data No. selection screen is displayed. Combination data No. which is selected at present and the contents are displayed in the upper part of the screen, and other combination data No. buttons which have been registered are displayed in the lower part of the screen.

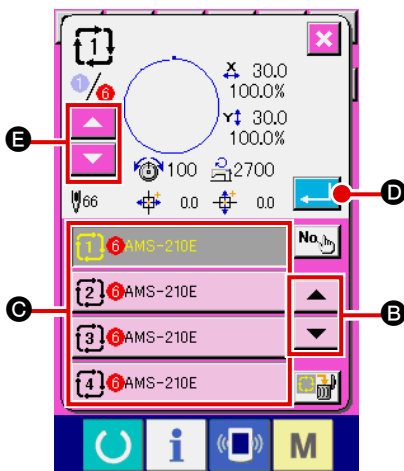

#### ③ Select the combination data No.

When UP/DOWN button  **B** is pressed, combination data No. buttons **C** which have been registered are changed over in order. Here, press the combination data No. buttons **C** you desire to select.

When STEP CONFIRMATION button  **E** is pressed, the sewing shapes of patterns which have been registered in the combination data and the like are changed over in order and displayed.

#### ④ Determine the combination data No.

When ENTER button  **D** is pressed, the combination data No. selection screen is closed and the selection is finished.

## (2) Creating procedure of the combination data

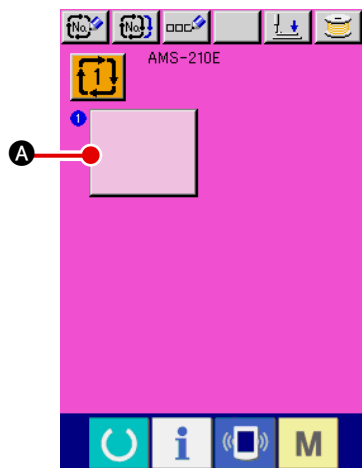

### ① Display the data input screen.

Only in case of the data input screen (pink) it is possible to input the combination data. In case of the sewing screen (green), press

READY switch  to display the data input screen (pink).

Pattern No. has not been registered in the initial state, and the first pattern selection button is displayed in the blank state.

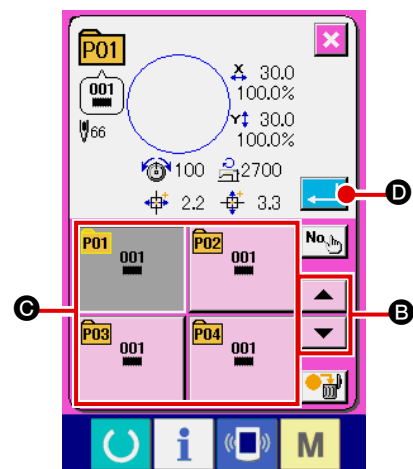

### ② Display the pattern No. selection screen.

When PATTERN SELECTION button  **A** is pressed, the pattern No. selection screen is displayed.

### ③ Select the pattern No.

When UP/DOWN SCROLL button  **B** is pressed, pattern No. buttons **C** which have been registered are changed over in order. The contents of pattern data are displayed in the buttons. Here, press the pattern No. buttons you desire to select.

### ④ Determine the pattern No.

When ENTER button  **D** is pressed, the pattern No. selection screen is closed and the selection is finished.

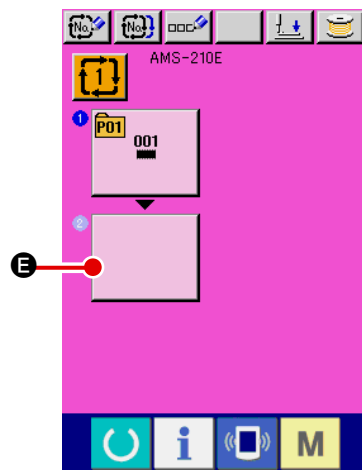

### ⑤ Repeat steps ② through ④ as many as the number of pattern Nos. you desire to register.

When the first register is determined, the second pattern selection button  **E** is displayed. Repeat steps ② through ④ as many as the number of pattern Nos. you desire to register.

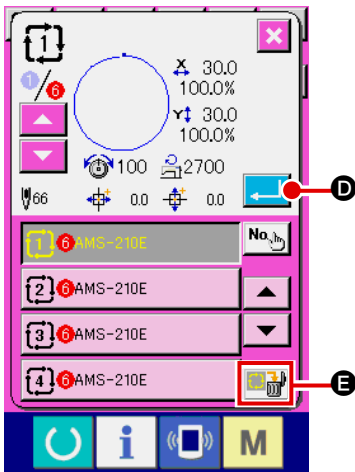

### (3) Deleting procedure of the combination data



- ① **Select the combination data No.**  
Perform steps ① to ③ of “II-2-22. (1) Selection of combination data” p.66 to display the combination data to be deleted.
- ② **Performing deleting the combination data.**  
When DATA DELETION button  **E** is pressed, the combination data deletion confirmation pop-up is displayed. Here, press ENTER button  **D**, and the selected combination data is deleted.

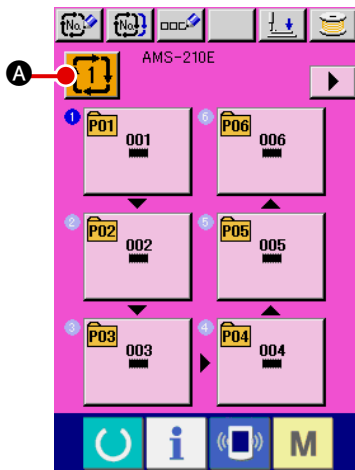

### (4) Deleting procedure of the step of the combination data

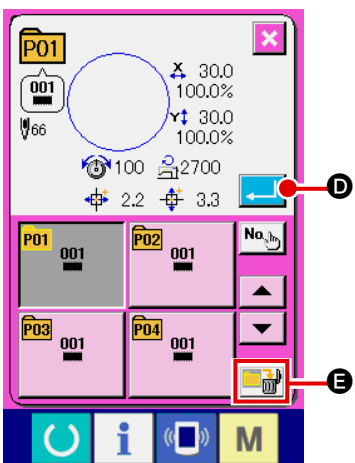

- ① **Select the combination data No.**  
Perform steps ① to ② of “II-2-22. (1) Selection of combination data” p.66 to make the state that the combination data including the step you desire to delete has been selected.

- ② **Display the pattern No. selection screen.**  
When PATTERN SELECTION button  **A** of the step you desire to delete is pressed, the pattern No. selection screen is displayed.



- ③ **Performing deleting the step of the selected combination data.**  
When DATA STEP DELETION button  **E** is pressed, the combination data step deletion confirmation pop-up is displayed. Here, press ENTER button  **D**, and the step of the selected combination data is deleted.



## 2-23. Changing memory switch data

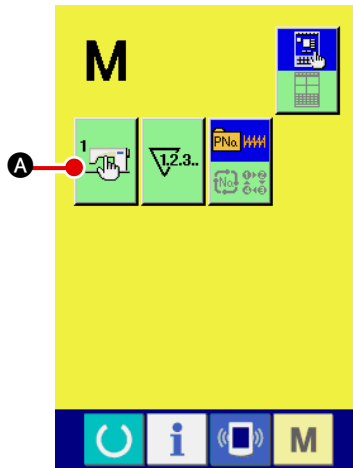

### ① Display the memory switch data list screen.

When MODE key **M** is pressed, memory switch button



**A** is displayed on the screen. When this button is pressed, the memory switch data list screen is displayed.

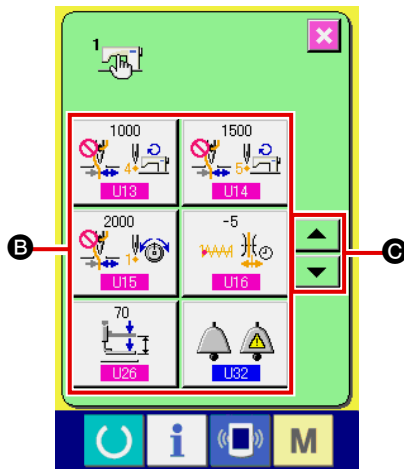



### ② Select the memory switch button you desire to change.

Press UP/DOWN SCROLL button  **C** and select the data item button **B** you desire to change.

### ③ Change the memory switch data.

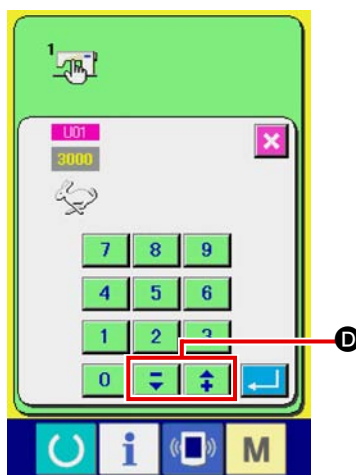
There are data items to change numerals and those to select pictographs in the memory switch data.



No. in pink color such as **U01** is put on the data items to change numerals and the set value can be changed with 

 **D** buttons displayed in the change screen.

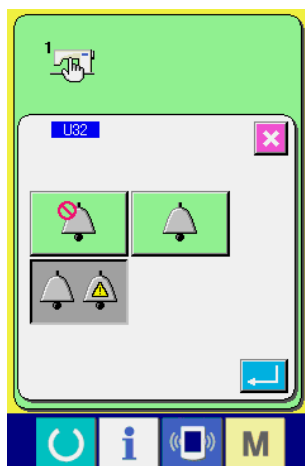

No. in blue color such as **U32** is put on the data items to select pictographs and the pictographs displayed in the change screen can be selected.

→ For the details of memory switch data, refer to " **II-4. MEMORY SWITCH DATA LIST**" p.104.

## 2-24. Using information

There are three functions below in the information function.

- 1) Oil replacement (grease-up) time, needle replacement time, cleaning time, etc. can be specified and the warning notice can be performed after the lapse of the specified time.  
Refer to "**II-2-24.(1) Observing the maintenance and inspection information**" p.70.
- 2) Speed can be checked at a glance and the target achieving consciousness as a line or group is increased as well by the function to display the target output and the actual output.  
Refer to "**II-2-24.(3) Observing the production control information**" p.72 and "**II-2-24.(4) Performing setting of the production control information**" p.74.
- 3) Information on machine working ratio, pitch time, machine time and machine speed can be displayed from the working state of the sewing machine.  
Refer to "**II-2-24.(5) Observing the working measurement information**" p.76.

### (1) Observing the maintenance and inspection information

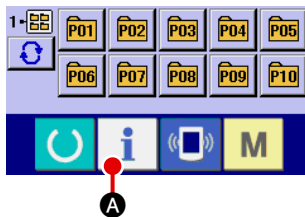

#### ① Display the information screen.

When information key  **A** of the switch seat section is pressed in the data input screen, the information screen is displayed.

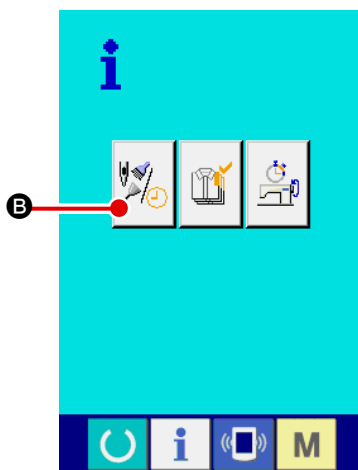



#### ② Display the maintenance and inspection information screen.

Press maintenance and inspection information screen display

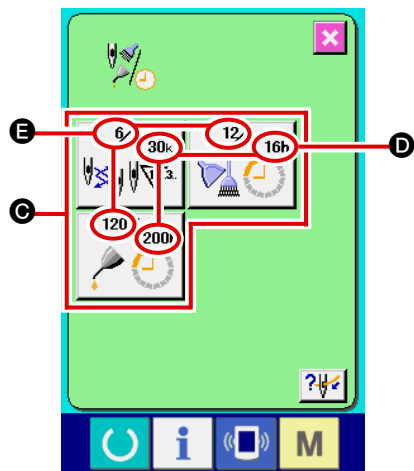
button  **B** in the information screen.



Information on the following three items is displayed in the maintenance and inspection information screen.

- Needle replacement (1,000 stitches) : 
- Cleaning time (hour) : 
- Oil replacement time (hour) : 

The interval to inform of the inspection for each item in button **C** is displayed at **D**, and remaining time up to the replacement is displayed at **E**. In addition, remaining time up to the replacement can be cleared.

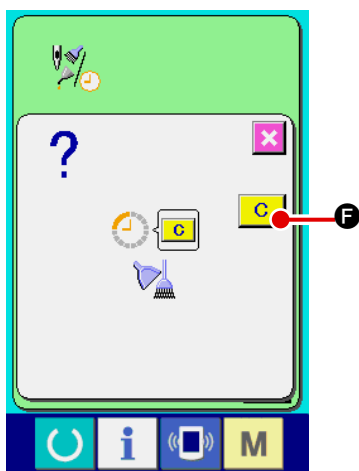

- ③ **Perform clearing remaining time up to the replacement.**  
When button **C** of the item you desire to clear is pressed, the time of replacement clear screen is displayed. When CLEAR button **C** **F** is pressed, the remaining time up to the replacement is cleared.

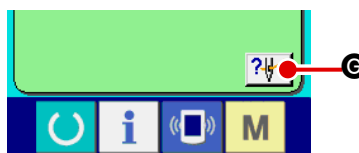

- ④ **Display the threading diagram.**  
When threading button  **G** displayed in the maintenance and inspection screen is pressed, the needle thread threading diagram is displayed. Observe it when performing threading.

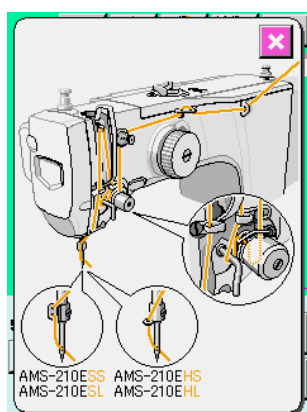

## (2) Releasing procedure of the warning

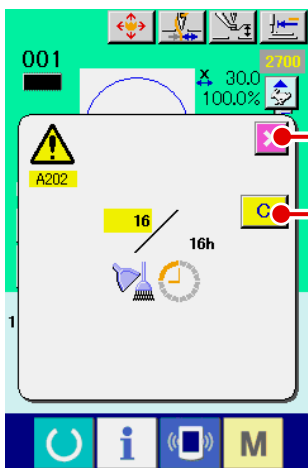

When the designated inspection time is reached, the warning screen is displayed.

In case of clearing the inspection time, press CLEAR button

**A**. The inspection time is cleared and the pop-up is closed. In case

of not clearing the inspection time, press CANCEL button

**B** and close the pop-up. Every time one sewing is completed, the warning screen is displayed until the inspection time is cleared.

Warning Nos. of the respective items are as follows.

- Needle replacement : A201
- Cleaning time : A202
- Oil replacement time : A203

For the grease-up portion, refer to the item of "III-1-12. Replenishing the designated places with grease" p.128.

## (3) Observing the production control information

It is possible to designate the start, display the number of pieces of production from the start to the existing time, display the number of pieces of production target, etc. in the production control screen. There are two kinds of display ways for the production control screen.

[When displaying from the information screen]

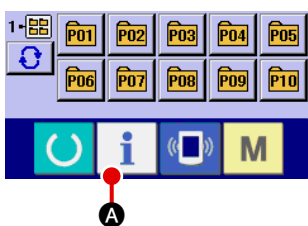

① **Display the information screen.**

When information key **A** of the switch seat section is pressed in the data input screen, the information screen is displayed.

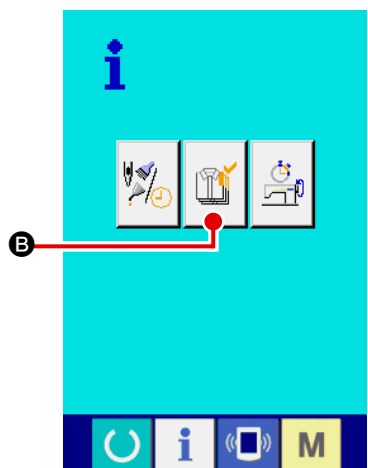

② **Display the production control screen.**

Press production control screen display button **B** in the information screen. The production control screen is displayed.

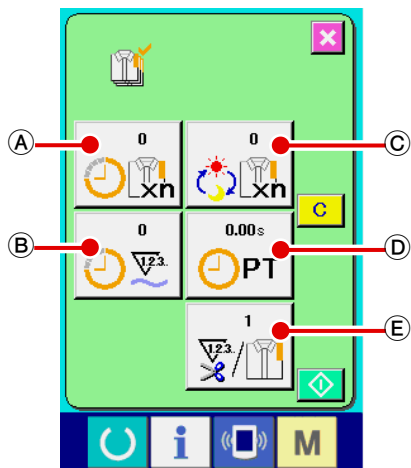

Information on the following 5 items is displayed in the production control screen.

- Ⓐ : Existing target value  
Number of pieces of the target of products at the present time is automatically displayed.
- Ⓑ : Actual results value  
Number of pieces of the sewn products is automatically displayed.
- Ⓒ : Final target value  
Number of pieces of the final target of products is displayed. Input the number of pieces referring to "II-2-24.(4) Performing setting of the production control information" p.74.
- Ⓓ : Pitch time  
Time (second) required for one process is displayed. Input the time (unit : second) referring to "II-2-24.(4) Performing setting of the production control information" p.74.
- Ⓔ : Number of times of thread trimming  
Number of times of thread trimming per process is displayed. Input the number of times referring to "II-2-24.(4) Performing setting of the production control information" p.74.

[ When displaying from the sewing screen ]

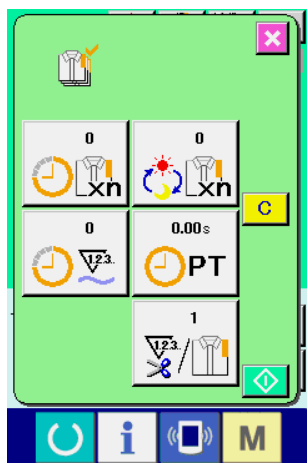
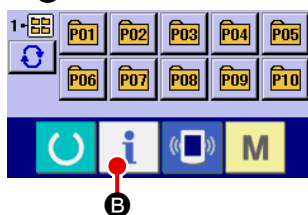

① Display the sewing screen.

When READY key  Ⓐ of the switch seat section is pressed in the data input screen, the sewing screen is displayed.

② Display the production control screen.

When information key  Ⓑ of the switch seat section is pressed in the sewing screen, the production control screen is displayed.

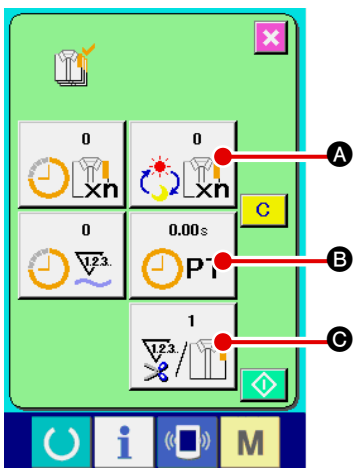

The contents of display and the functions are common to "[When displaying from the information screen]".

#### (4) Performing setting of the production control information



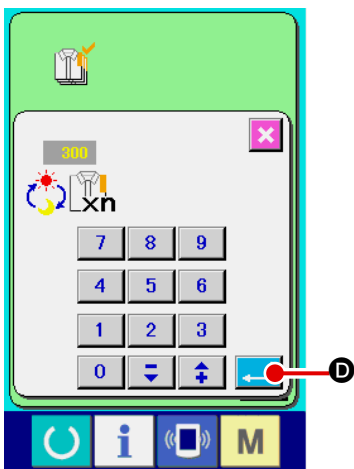

- ① **Display the production control screen.**  
 Display the production control screen referring to "II-2-24.(3) Observing the production control information" p.72.



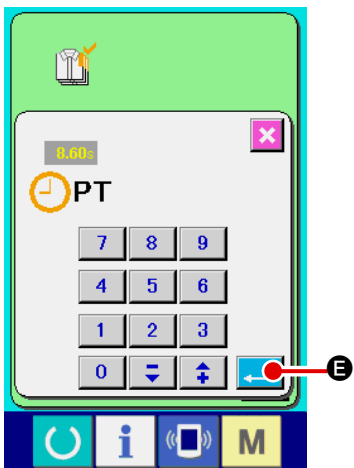

- ② **Input the final target value.**  
 First, input the number of pieces of the target of production in the process to which sewing is performed from now on. When final target value button  A is pressed, the final target value input screen is displayed.  
 Input the value you desire with ten keys or UP/DOWN buttons. After the input, press ENTER button  D.

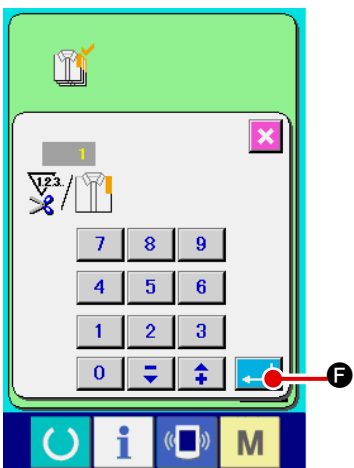

- ③ **Input the pitch time.**  
 Next, input the pitch time required for one process. When PITCH button  B of the aforementioned item 1) is pressed, the pitch time input screen is displayed.  
 Input the value you desire with ten keys or UP/DOWN buttons. After the input, press ENTER button  E.



- ④ **Input the number of times of thread trimming.**  
 Next, input the number of times of thread trimming per process.  
 When number of times of thread trimming button  C in the previous page is pressed, the number of times of thread trimming input screen is displayed.  
 Input the value you desire with ten keys or UP/DOWN buttons. After the input, press ENTER button  F.

\* **When the input value is "0", count of the number of times of thread trimming is not performed. Use this function by connecting the external switch.**

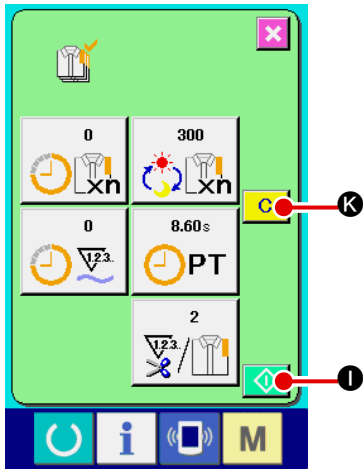

⑤ **Start the count of number of pieces of production.**

When START button (I) is pressed, the count of number of pieces of production is started.

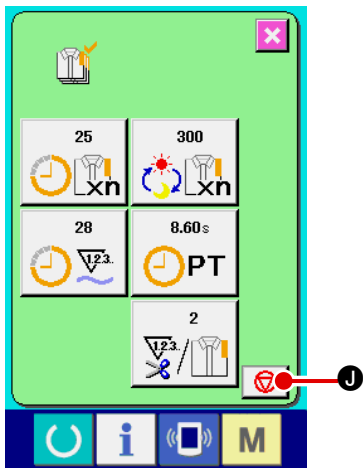

⑥ **Stop the count.**

Display the production control screen referring to "II-2-24.(3) Observing the production control information" p.72.

When the count is being performed, STOP switch (J) is displayed. When STOP button (J) is pressed, the count is stopped.

After the stop, START button (I) is displayed at the position of STOP button. When continuing the count, press START button (I) again. The counted value is not cleared until CLEAR button (K) is pressed.

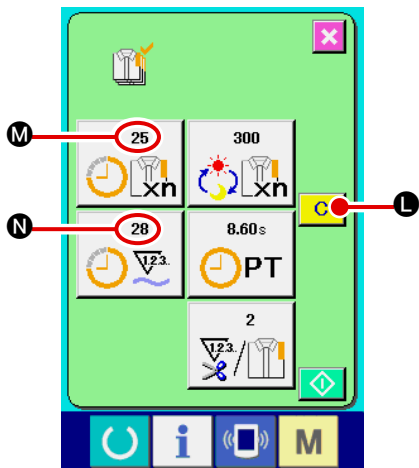

⑦ **Clear the counted value.**

When clearing the counted value, set the count to the stop state and press CLEAR button (L).

The value to be cleared is the present target value (M) and actual results value (N) only.

\* **CLEAR button is displayed only in case of stop state.**

When CLEAR button (L) is pressed, the clear confirmation screen is displayed.

When CLEAR button (O) is pressed in the clear confirmation screen, the counted value is cleared.

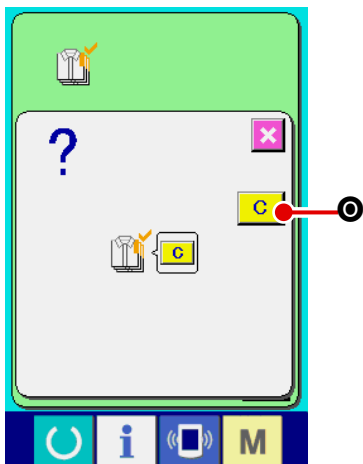

## (5) Observing the working measurement information

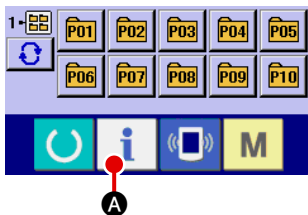

### ① Display the information screen.

When information key **i** **A** of the switch seat section is pressed in the data input screen, the information screen is displayed.

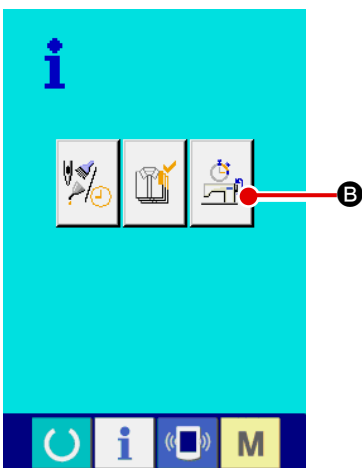

### ② Display the working measurement screen.

Press working measurement screen display button  **B** in the information screen. The working measurement screen is displayed.

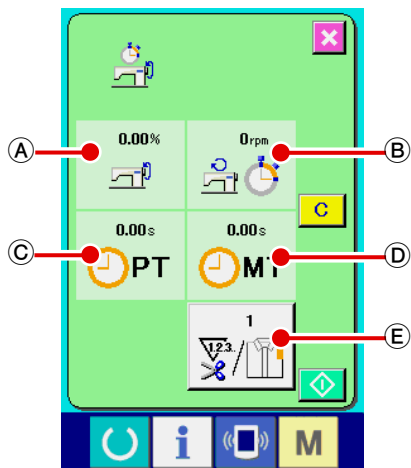

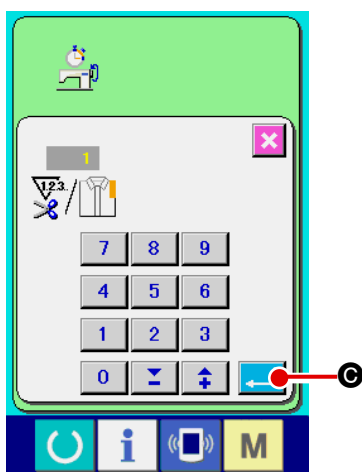

Information on the following 5 items are displayed in the working measurement screen.

- Ⓐ : The information is automatically displayed from the time of start of measuring the working ratio.
- Ⓑ : The information is automatically displayed from the time of start of measuring the machine speed.
- Ⓒ : The information is automatically displayed from the time of start of measuring the pitch time.
- Ⓓ : The information is automatically displayed from the time of start of measuring the machine time.
- Ⓔ : Number of times of thread trimming is Input the number of times referring to item 3) on the next page.



### ③ Input the number of times of thread trimming.

Next, input the number of times of thread trimming per process. When NUMBER OF TIMES OF THREAD TRIMMING button  **E** is pressed, the number of times of thread trimming input screen is displayed. Input the value you desire with ten keys or UP/DOWN buttons. After the input, press ENTER button  **C**.

\* When the input value is 0, count of the number of times of thread trimming is not performed. Use this function by connecting the external switch.



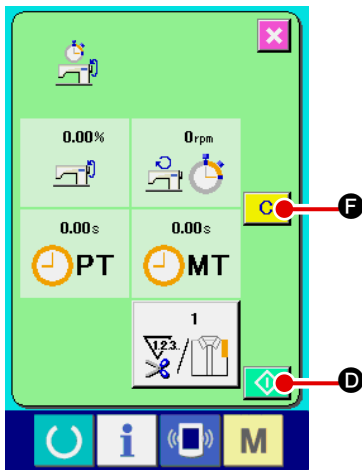



④ **Start the measurement.**

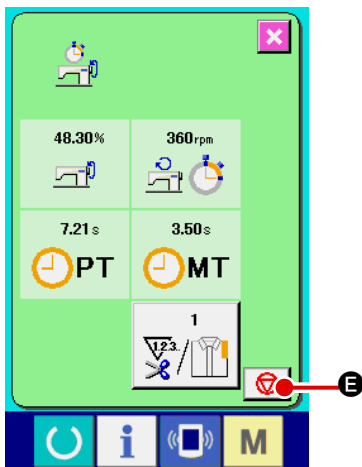

When START button  **D** is pressed, measurement of each data is started.



⑤ **Stop the count.**

Display the working measurement screen referring to 1) and 2) of "**II-2-24.(5) Observing the working measurement information**" p.76.

STOP switch  **E** is displayed when the measurement is being performed. When STOP switch  **E** is pressed, the measurement is stopped.

After the stop, START button  **D** is displayed at the position of STOP button. To continue measuring, press START button  **D** again. The measured value is not cleared until CLEAR button  **F** is pressed.

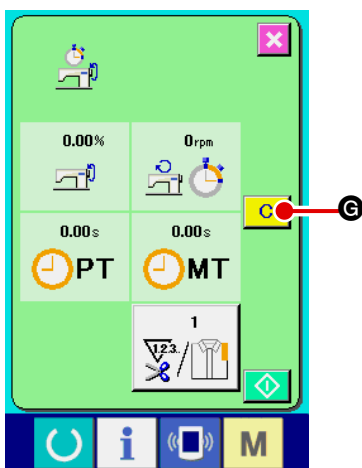



⑥ **Clear the counted value.**

When clearing the counted value, set the count to the stop state and press CLEAR button  **G**.

\* **CLEAR button is displayed in case of the stop state only.**

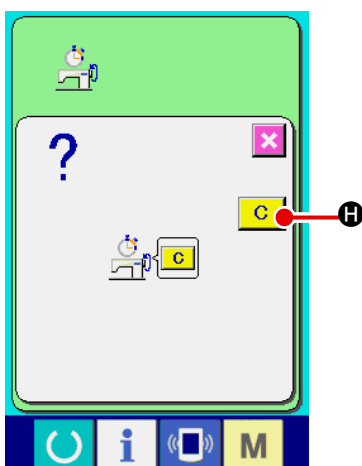
When CLEAR button  **G** is pressed, the clear confirmation screen is displayed.



When CLEAR button  **H** is pressed in the clear confirmation screen, the counted value is cleared.

## 2-25. Using communication function



Communication function can download the sewing data created with other sewing machine, creation of sewing data and sewing data created by editing device PM-1 to the sewing machine. In addition, the function can upload the aforementioned data to the media or personal computer.

Media and RS-232C port are prepared as the means to communicate.

- \* However, SU-1 (data server utility) is necessary to perform download/upload from the personal computer.

### (1) Handling possible data

Sewing data that can be handled are 4 kinds below, and the respective data formats are as shown below.

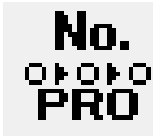
Data name		Extension	Description of data
Vector format data		VD00XXX.VDT	It is the data of needle entry point created with PM-1, and the data format that can be operated in common between JUKI sewing machines.
M3 data		AMS0XXX.M3	Pattern data of AMS-210D series
Sewing standard format data		SD00XXX.DAT	Data of sewing standard format
Simplified program data		AMS0XXX.PRO	Simplified program data

xxx : file No.

- \* For the simplified program, see the Engineer's Manual.

## (2) Performing communication by using the media

For handling way of the media, read "**II -1. PREFACE**" p.25.

## (3) Performing communication by using RS-232C

### [ Setting procedure ]

It is possible to send and receive the data, by using RS-232C cable, with the personal computer or the like. For the cable to be connected, connect reverse type 9-pin (female) to the operation panel side.



If the contact part becomes dirty, failure of contact will be caused. Do not touch by hand, and control so that dust, oil or other foreign material does not adhere to it. In addition, the inside element is damaged by static electricity or the like. So, be very careful when handling.

- \* When the lower part of the cover located on the side of the operation panel is opened, there is the connector of 9-pin for RS-232C. Connect the cable there. When the screw for locking is attached to the connector, tighten the screw to prevent it from falling.

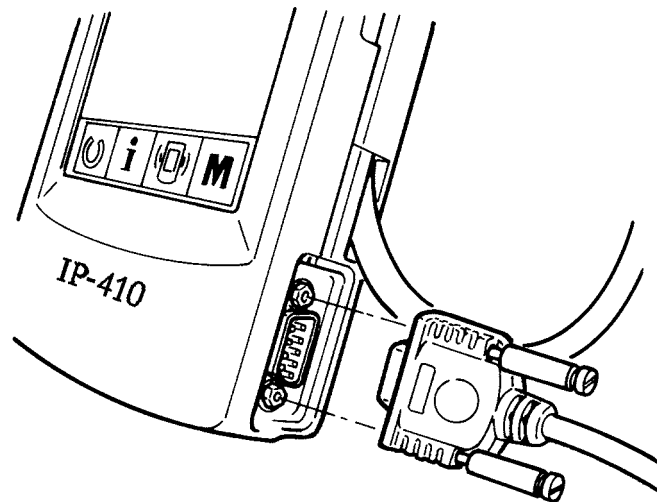

#### (4) Take-in of the data

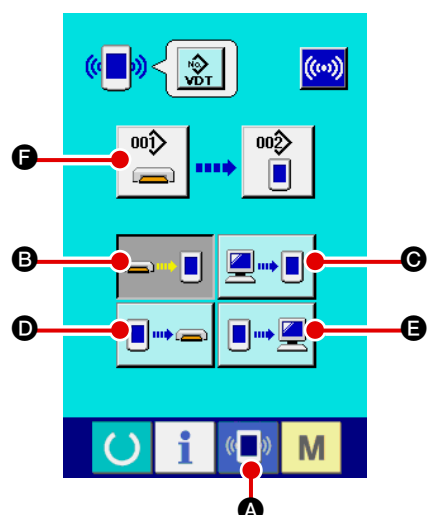

##### ① Display the communication screen.

When communication switch  **A** of switch seat section is pressed in the data input screen, the communication screen is displayed.

##### ② Select the communication procedure.

There are four communication procedures as described below.

- B** Writing data from media to panel
- C** Writing data from personal computer (server) to panel
- D** Writing data from panel to media
- E** Writing data from panel to personal computer (server)

Select the button of communication procedure you desire.

##### ③ Select the data No.

When  **F** is pressed, the writing file selection screen is displayed.

Input the file No. of the data you desire to write. For the file No., input the numerals of the part xxx of VD00xxx .vdt of the file name.

Designation of the pattern No. of writing destination can be performed in the same way. When the writing destination is the panel, pattern Nos. which have not been registered are displayed.

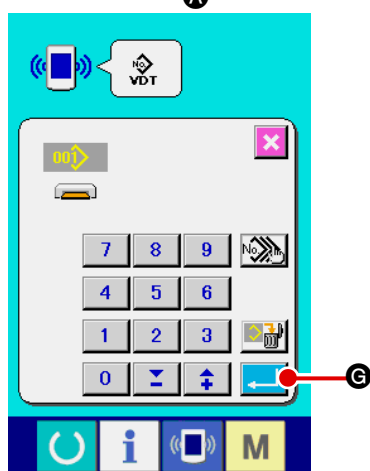

##### ④ Determine the data No.

When ENTER button  **G** is pressed, the data No. selection screen is closed and the selection of the data No. has been completed.

##### ⑤ Start communication.

When COMMUNICATION START button  **H** is pressed, the data communication starts. The during communication screen is displayed during communication and the screen returns to the communication screen after the end of communication.

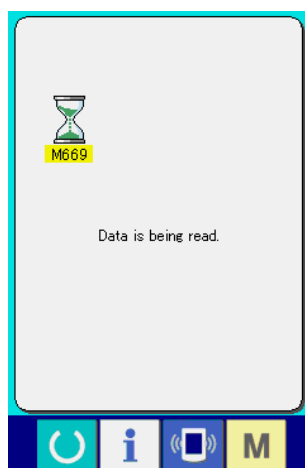
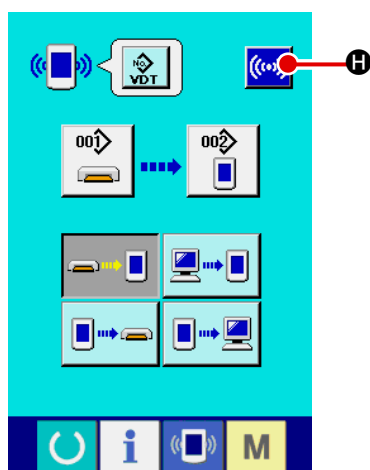

## (5) Taking in plural data together

It is possible for vector data, M3 data and sewing standard format data to select plural writing data and write them together. Pattern No. of writing destination will become the same No. of the selected data No.



It is not possible for the No. after No. 201 of media to select plural No.

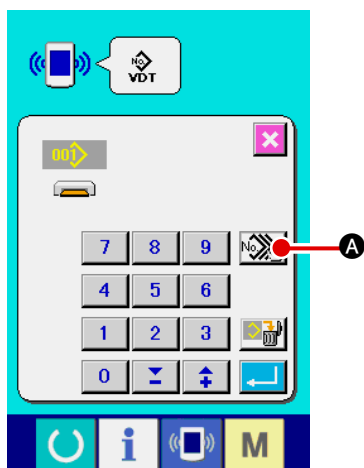

### ① Display the writing file selection screen.

When PLURAL SELECTION button  **A** is pressed, the data No. plural selection screen is displayed.

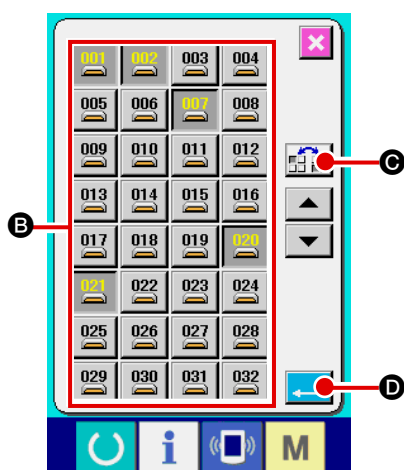

### ② Perform the data No. selection.

Since the list of existing data file numbers is displayed, press FILE NO. button **B** you desire to write. It is possible to invert the selected state of the button with INVERSION button 

**C.**

### ③ Determine the data No.

When ENTER button  **D** is pressed, the data No. plural selection screen is closed and the data selection ends.

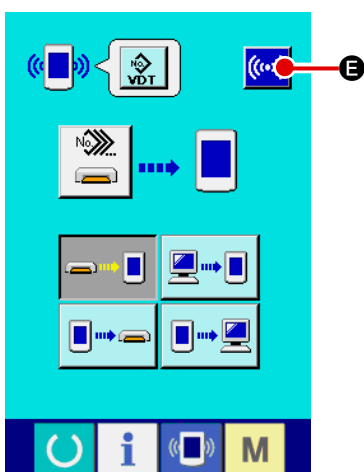

### ④ Start the communication.

When COMMUNICATION START button  **E** is pressed, the data communication starts.

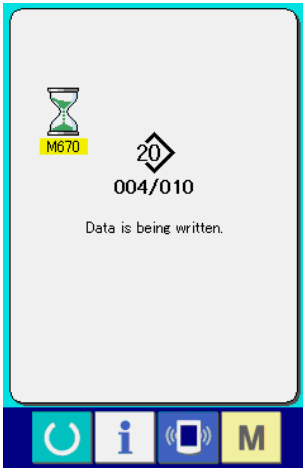

Data No. during communication, total number of writing data and number of data that have ended the data communication are displayed in the during communication screen.

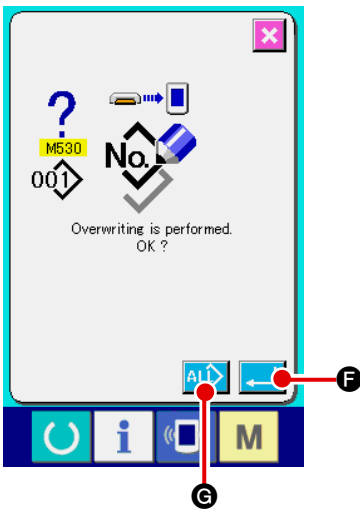

\* When performing writing to the pattern No. which already exists, the overwriting confirmation screen is displayed before writing. When performing overwriting, press ENTER button



When performing overwriting all without displaying the overwriting confirmation screen, press OVERWRITING button

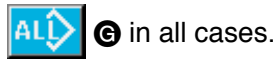

## 2-26. Performing formatting of the media

When re-formatting the media, be sure to perform it with IP-410 or IP-400. The media that is formatted with the personal computer cannot be read with IP-410 and the CP-20.

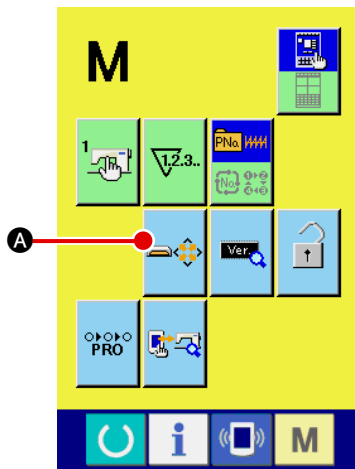

### ① Display the media format screen.

When **M** switch is held pressed for three seconds, MEDIA

FORMAT button  **A** is displayed on the screen. When this button is pressed, the media format screen is displayed.

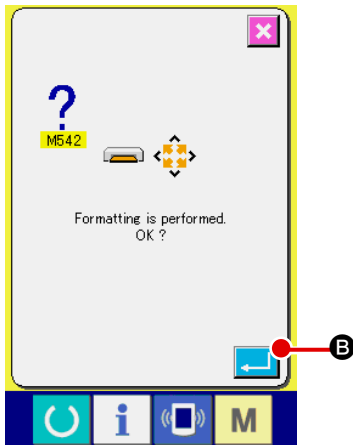

### ② Start formatting of the media.

Set the media you desire to format to the media slot, close the cover, press ENTER button  **B** and formatting starts.

Save necessary data in the media to the other media before formatting. When formatting is performed, the inside data are deleted.

### 3. WHEN USING CP-20

#### 3-1. Name of each section of CP-20

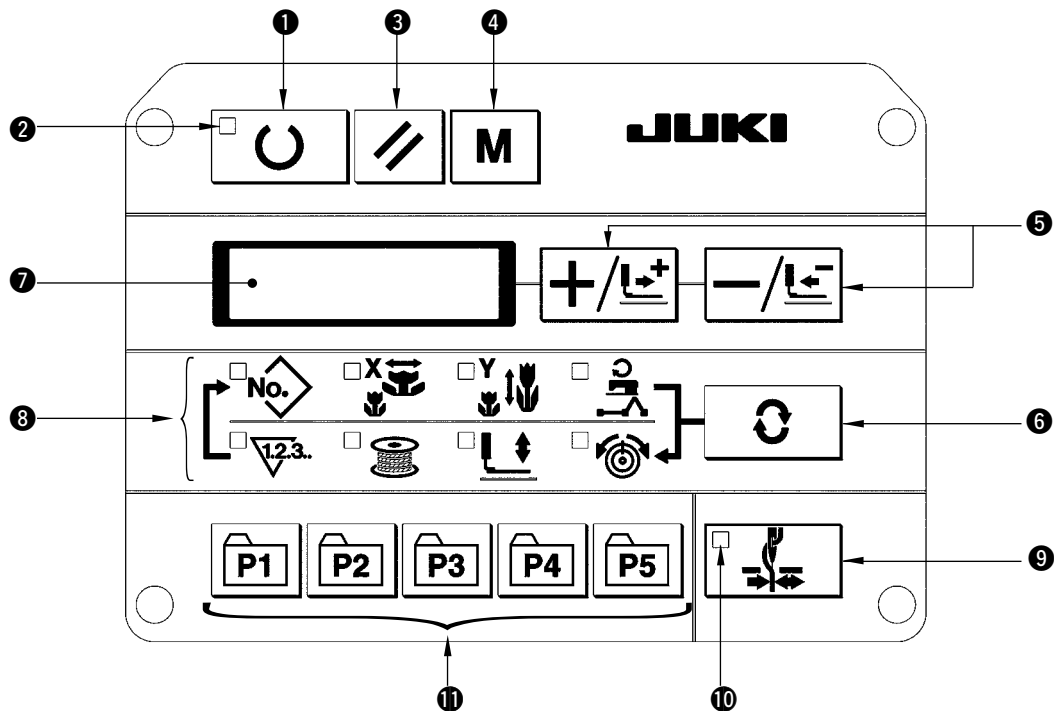

**1 “Ready” key**

This key changes over the setting state from the panel to the sewing state where the sewing machine actually operates.

**2 Sewing LED**

This LED goes off at the time of setting state and lights up at the time of sewing state. Changeover can be performed with “Ready” key.

**3 “Reset” key**

This key is used for canceling error or returning the set value to the initial value.

**4 “Mode” key**

This key makes the setting mode of the memory switch.

**5 “+ / Feed forward” key and “- / Feed backward” key**

This key is used for changing pattern No. and X/Y scale, and feed forward/feed backward.

**6 “Selection” key**

This key selects the item to be set. Item selection LED of the selected item and the set value are displayed.

**7 Data indication LED**

This LED indicates the set values of the selected items such as pattern No., X/Y scale, etc.

**8 Item selection LED**

LED of the selected items light up.



Pattern No.



X scale



Y scale



Max. speed limitation



Sewing counter



Bobbin winder



Intermediate presser height



Thread tension

**9 Needle thread clamp ON/OFF key**

This key selects effective/ineffective of needle thread clamp. When it is effective, needle thread clamp display LED lights up.

**10 Needle thread clamp display LED**

When this LED lights up, needle thread clamp operates.

**11 Needle thread clamp display LED**

This key registers the pattern. When this key is pressed, the pattern registered here can sew immediately. X/Y scale, sewing position, etc. can be changed and registered.



## 3-2. Operation of CP-20 (Basic)

Store the vector format data to the specified folder referring to "**II-1-3) Folder structure of the media**" p.26. Properly insert the smart media and securely close the lid of the cover.



**Be sure to use the smart media that has been formatted with IP-400.**

**For the formatting procedure of the smart media, refer to**

**"II-2-26. Performing formatting of the media" p.83.**

### (1) Item data setting

Set each item following the procedure described below.

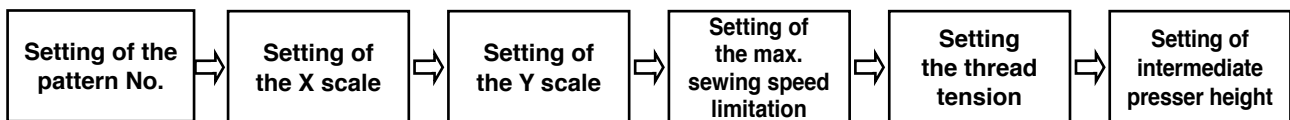

#### ① Turn ON the power switch.

Pattern No. of the item selection lights up, and the pattern No. is indicated on the data display.

#### ② Setting of the pattern No. (Example : when setting pattern No. S.61)

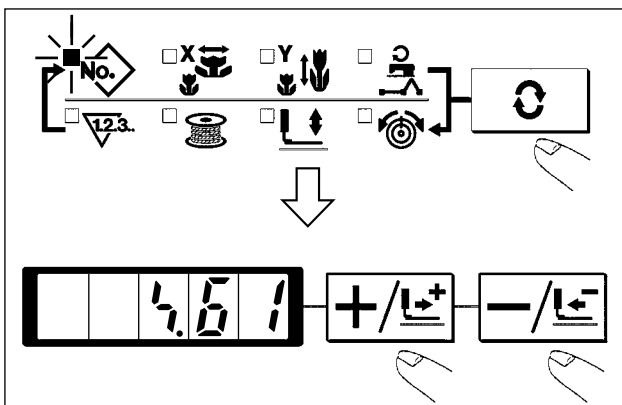

- 1) Press the key to indicate the item "Pattern NO" .
- 2) Press the or key to indicate "S.61" on the display.

#### ③ Setting of the X scale (Example : when setting 100.0%)

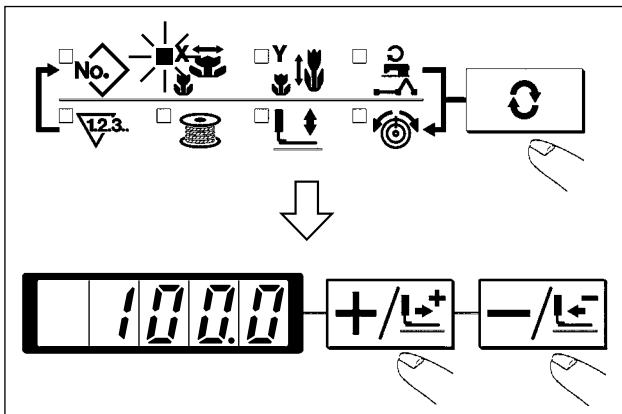

- 1) Press the key to indicate the item "X Scale" .
- 2) Press or key, and set the ratio within the range of 1.0% to 400.0%.

④ Setting of the Y scale (Example : when setting 100.0%)

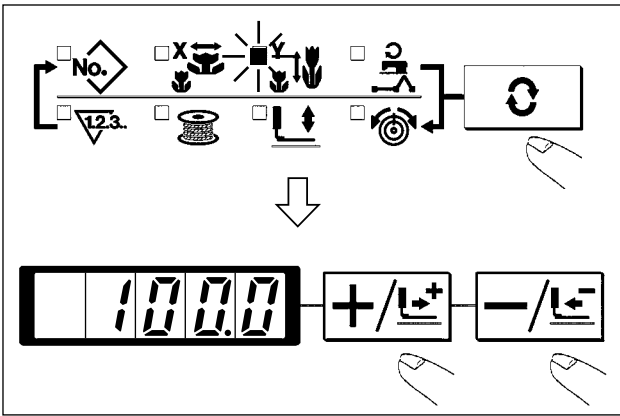

- 1) Press the key to indicate the item "Y Scale" .
- 2) Press or key, and set the ratio within the range of 1.0% to 400.0%.

⑤ Setting of the max. sewing speed limitation (Example : when setting 400 rpm)

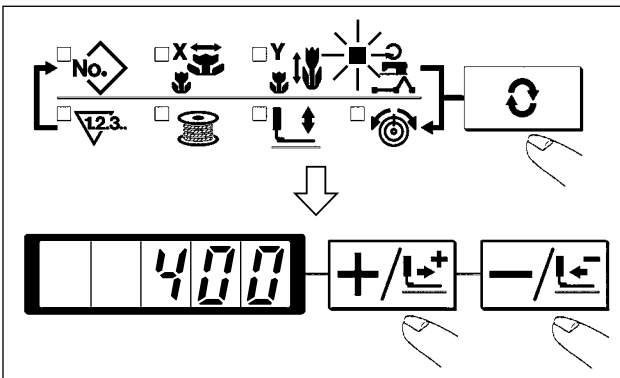

- 1) Press the key to indicate the item "Speed" .
- 2) Press or key to indicate "400". (Setting of 400 rpm)

⑥ Setting the thread tension (Example : when setting thread tension 30)

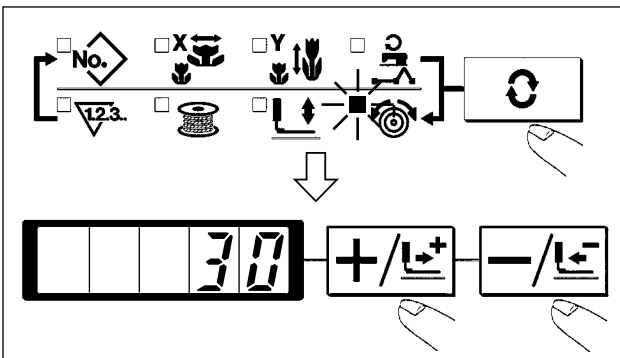

- 1) Press key to indicate the item "THREAD TENSION" .
- 2) Press or key to indicate "30". (0 to 200 can be set.)

⑦ Setting of the intermediate presser height (Example : when setting intermediate presser height 30)

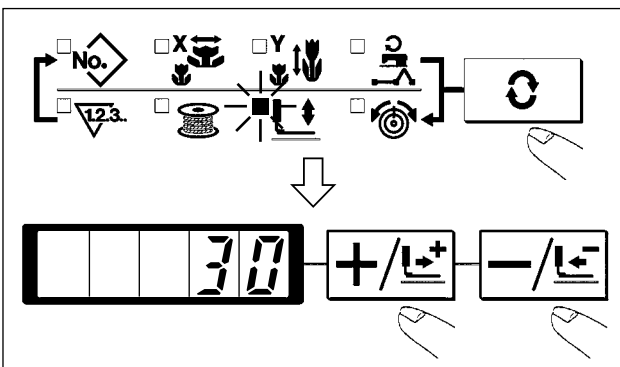

- 1) Press key to indicate the item "INTERMEDIATE PRESSER" .
- 2) Press or key to display "30" in the screen. (0 to 3.5 (Max 0 to 7.0) can be set.)



Setting range can be changed with memory switch U112. However, set the setting range to max. 3.5 mm, when using DPX5 needle, to protect the intermediate presser from interfering with the needle bar.

## ⑧ Finish of setting

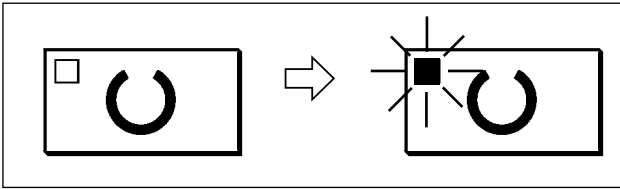

- 1) Press the key.
- 2) After the work clamp feet have moved and gone up, the sewing LED lights up, and the sewing is ready.



1. When the data is changed, press to confirm the change.
2. When selecting the items of the height of the intermediate presser and the bobbin winder, the machine cannot move to the sewing state. Select other items.
3. If key is pressed, you can make sure of the respective setting items again. However, the items can not be changed in the state that the SEWING LED is lit up.
4. When key is pressed, the READY LED goes off. Set values of the respective items can be changed.
5. Thread tension can be changed even when the sewing LED lights up.
6. Use the machine after confirming the pattern No. When key is pressed while pattern No. is indicated "0" (state at the time of delivery), error display E-10 appears. At this time, re-set the pattern No.
7. Change of the height of the intermediate presser and the bobbin winder fail to work immediately after turning ON the power. Use the machine after pressing READY key and performing the origin retrieval.

## (2) Checking the contour of a sewing pattern



### WARNING :

Make sure without fail of the contour of the sewing pattern after selection of the sewing pattern. If the sewing pattern extends outside the work clamp feet, the needle will interfere with the work clamp feet during sewing, causing dangerous troubles including needle breakage.

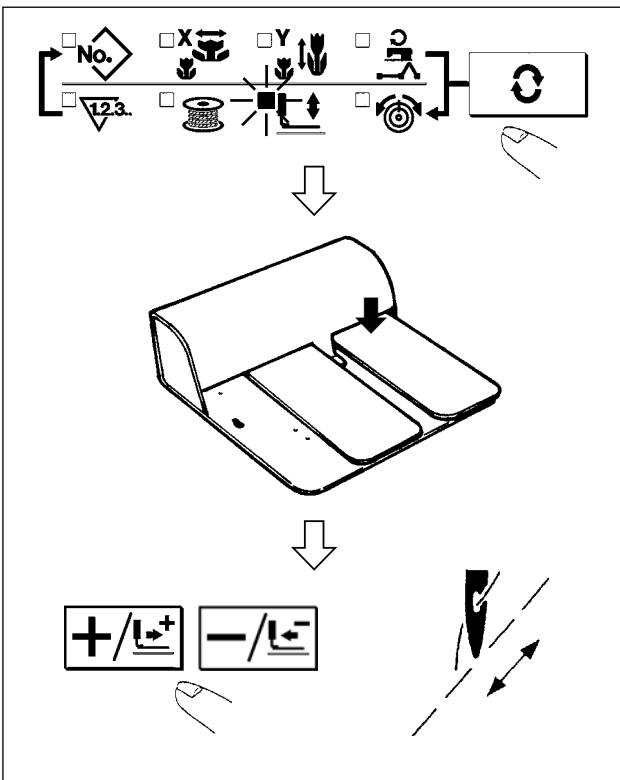

- 1) Press key to make the READY LED light up.
- 2) Select the "INTERMEDIATE PRESSER" with key.
- 3) Lower the work clamp feet with the foot switch.



The sewing machine does not start even when the foot switch is depressed under this mode.

- 4) Press key in the state that the work clamp feet are lowered.



The work clamp feet do not go up even when the foot switch is detached.

- 5) Confirm the contour of the pattern with key or key.
- 6) The work clamp feet will go up when key is pressed.

### (3) Performing modification of the needle entry point

When commands of thread tension or intermediate presser height exist in the needle entry point of the shape confirmation and during temporary stop, those values can be modified.

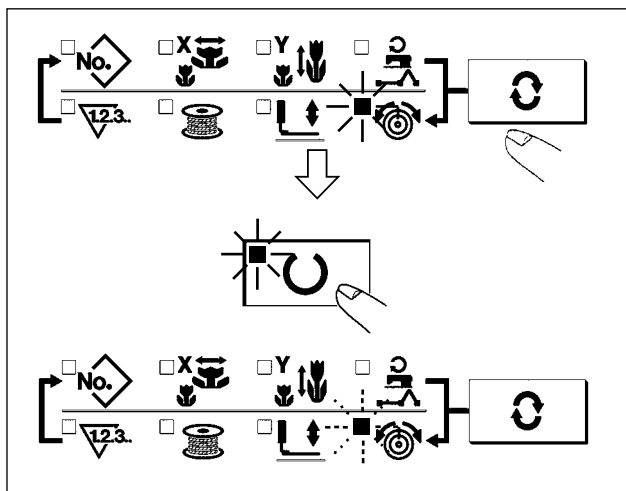

#### • Changing the thread tension reference value

- 1) Press key in the ready state to select the thread tension.
- 2) Press key for 5 seconds or more with the feeding frame lowered.
- 3) The sewing LED lights up and thread tension LED flashes on and off.
- 4) Set the thread tension reference value with key or key.

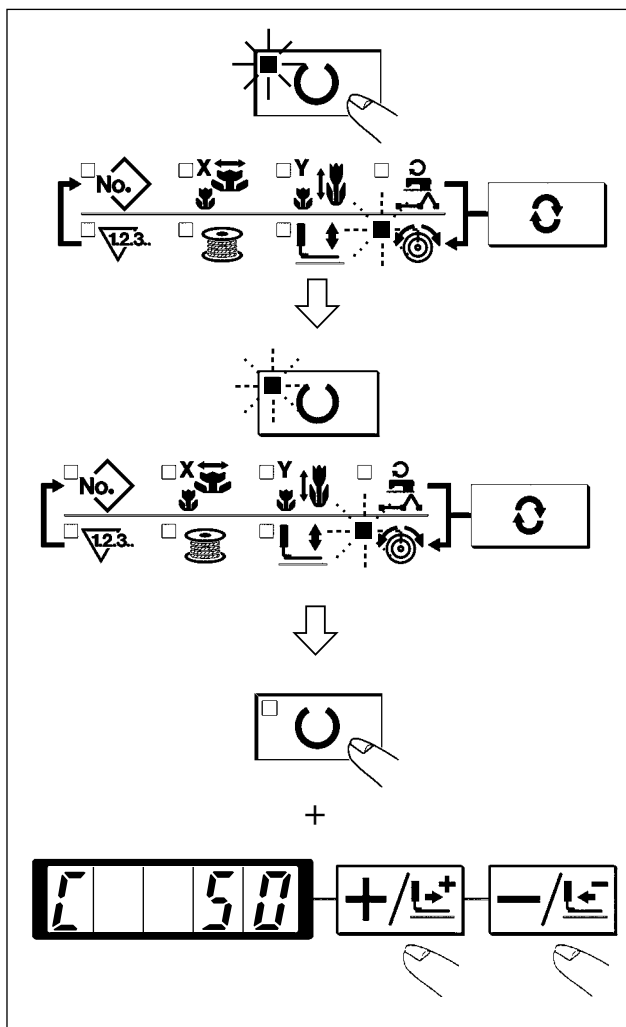

#### • Changing the thread tension command value





- 1) Press key in the aforementioned reference value change state.
- 2) Both the sewing LED and the thread tension LED flash on and off.
- 3) Continue stitching with key or key.
- 4) "C" is displayed when there is the thread tension command in the current needle entry point.
- 5) Pressing key, set the thread tension command value with key or key.
- 6) When ending the setting, press key.

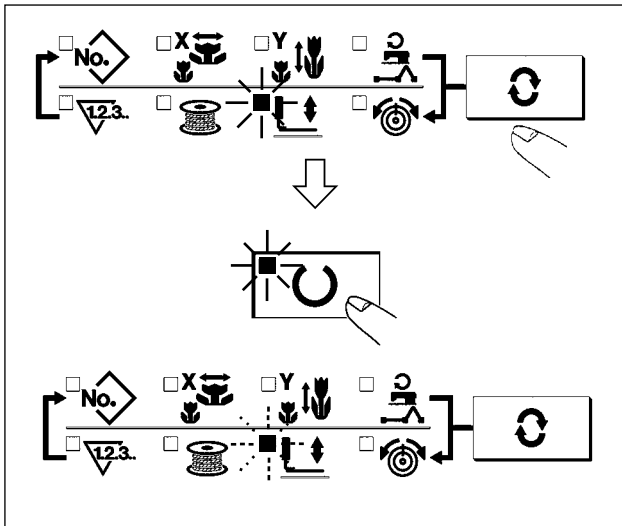

**When checking the needle, or performing the feed forward or backward, the machine fails to work unless the presser is lowered. Use the machine after lowering the presser.**







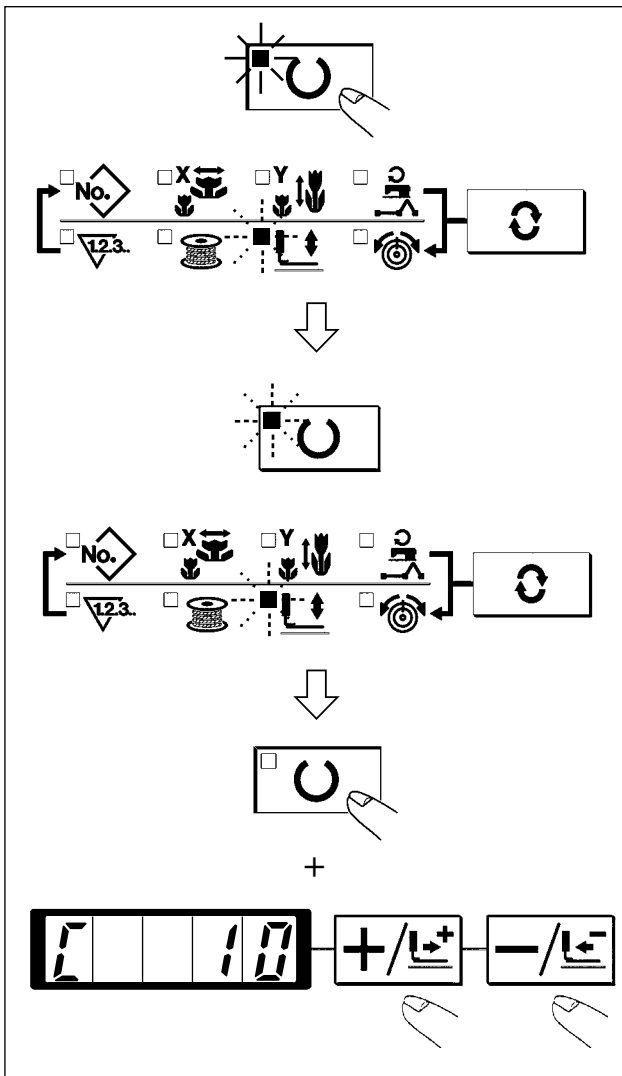

• **Changing the intermediate presser reference value**

- 1) Press  key in the ready state to select the intermediate presser.
- 2) Press  key for 5 seconds or more with the feeding frame lowered.
- 3) The sewing LED lights up and the intermediate presser LED flashes on and off.
- 4) Set the intermediate presser reference value with  key or  key.



• **Changing the intermediate presser command value**

- 1) Press  key in the aforementioned reference value change state.
- 2) Both the sewing LED and the intermediate presser LED flash on and off.
- 3) Continue stitching with  key or  key.
- 4) "C" is displayed when there is the intermediate presser command in the current needle entry point.
- 5) Pressing  key, set the intermediate presser command value with  key or  key.
- 6) When ending the setting, press  key.



1. When checking the needle, or performing the feed forward or backward, the machine fails to work unless the presser is lowered. Use the machine after lowering the presser.
2. When increasing the height of intermediate presser or making the needle size thicker, confirm the clearance between the wiper and the components. Wiper cannot be used unless the clearance is secured. In this case, turn OFF the wiper switch, or change the set value of memory switch U105.

#### (4) When the pattern is changed

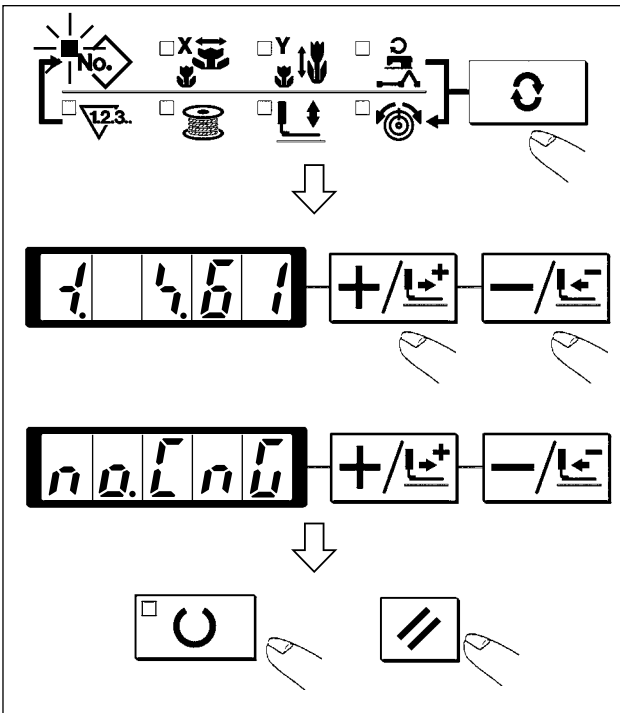

- 1) When X/Y enlargement/reduction ratio, thread tension value, and intermediate presser height of the data of the vector format are changed, and key is pressed, the display is in the pattern No. selection state as shown in the figure.

When you desire to change the pattern No. in this state, the display becomes the pattern No. change confirmation display.

When destroying the contents of the current pattern and changing the pattern No., press key, and when canceling the change of pattern No., press key.

In order to store the changed pattern, see "**II-3-3. Performing copying of pattern**" p.90.

### 3-3. Performing copying of pattern

Copying below can be performed under the pattern copy mode.

- Copying from vector format data to users' pattern
- Copying between vector format data
- Copying from users' pattern to vector format data
- Copying between users' patterns

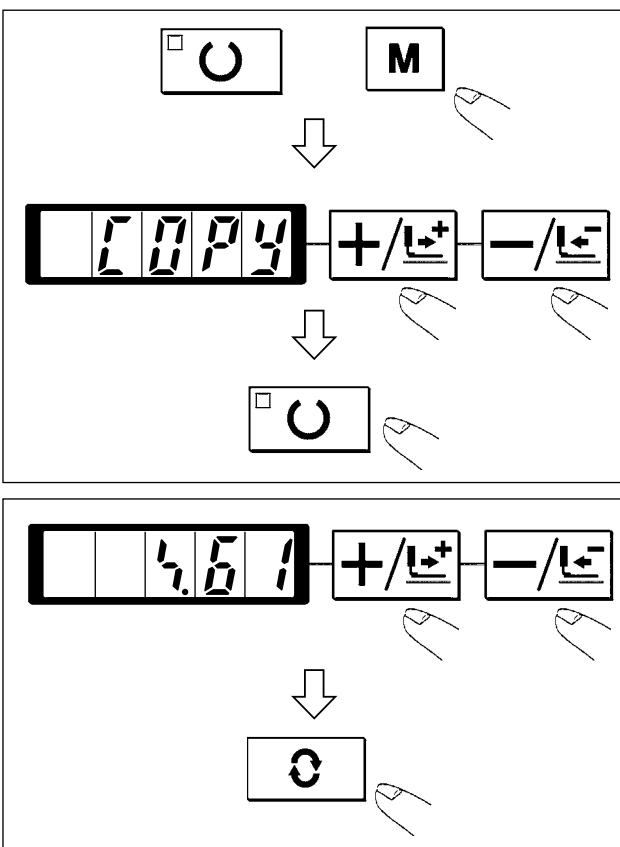

- 1) Confirm that sewing LED went out, and press key.

Display the copy mode with key or key, and press key.

- 2) First set No. of the copy source. Select the pattern No. of copy source with key or key.

Here the registered vector format data, users' pattern and the edited vector format data can be selected.

When No. of the copy source is determined, press key to set No. of the copy destination in the set state.

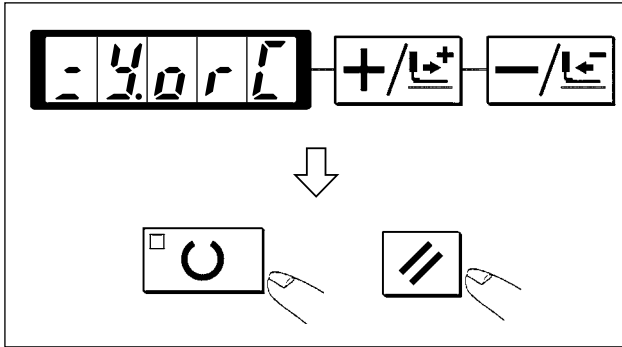
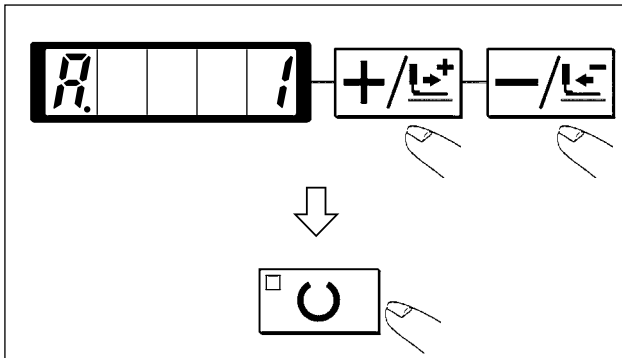

3) Next, set No. of the copy destination. Select pattern No. of the copy destination with **+/L+** key or **-/L-** key. Here vector format data 1 to 999 and users' pattern 1 to 200 can be selected. A is displayed to the No. which is not registered yet, and 0 is displayed to the No. which has been registered.

When No. can be selected, determine it with **U** key.

4) When trying to copy to the registered pattern No., the overwriting confirming state is produced. When performing the overwriting, press **U** key, and when canceling, press **U** key.

### 3-4. Performing deletion of pattern

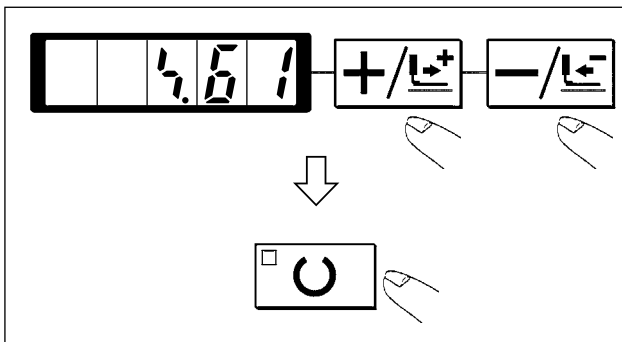
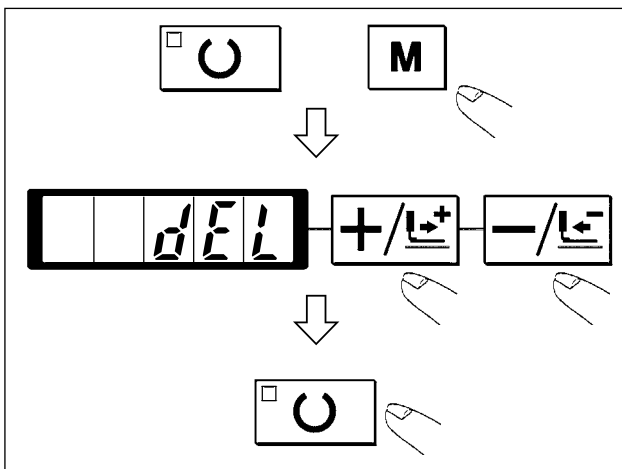

1) Confirm that the sewing LED has gone out, and press **M** key.

Display the deletion mode, and press **U** key with **+/L+** key or **-/L-** key.

2) Set the deletion No.

Select the pattern No. to be deleted with **+/L+** key or **-/L-** key, and press **U** key.

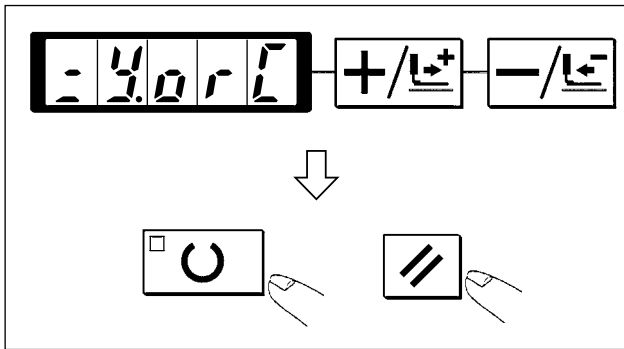

- 3) The deletion confirmation state is produced. When executing the deletion without change, press key, and when canceling, press key.

### 3-5. Sewing

\* For the sewing procedure, see "I-5-1. Sewing" p.22.

#### (1) Change to the other sewing pattern



#### WARNING :

Make sure without fail of the contour of the sewing pattern after selection of the sewing pattern. If the sewing pattern extends outside the work clamp feet, the needle will interfere with the work clamp feet during sewing, causing dangerous troubles including needle breakage.

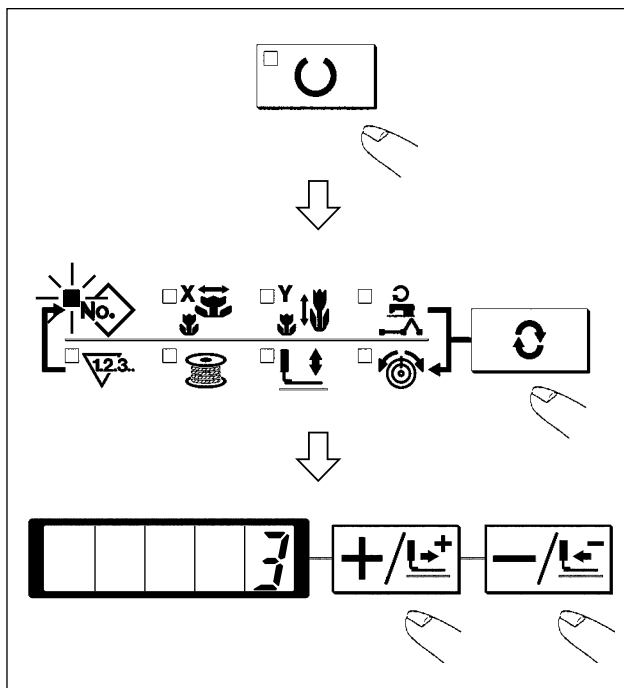

- 1) Make the Sewing LED go off with key.
- 2) Press key and select the item of pattern No. .
- 3) Set the pattern No. with key or key.
- 4) Similarly, setting of X/Y scale, speed, etc. is performed.
- 5) When key is pressed, the Sewing LED lights up and the sewing machine is in the sewing ready state.



### 3-6. Winding bobbin

#### (1) To wind a bobbin while the sewing machine is performing sewing

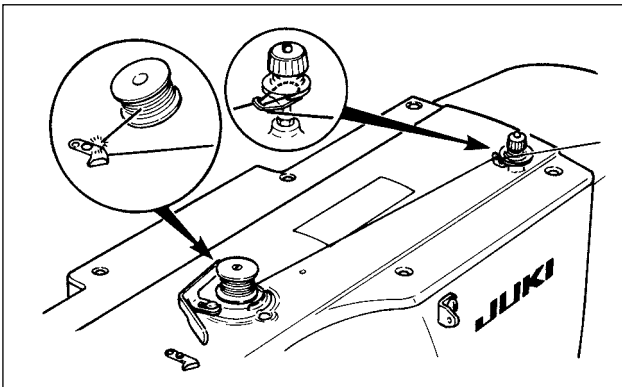

Thread the bobbin winder and wind the bobbin thread onto the bobbin as illustrated in the figure.

#### (2) To wind a bobbin independently



#### WARNING :

Make sure without fail of the contour of the sewing pattern after selection of the sewing pattern. If the sewing pattern extends outside the work clamp feet, the needle will interfere with the work clamp feet during sewing, causing dangerous troubles including needle breakage.

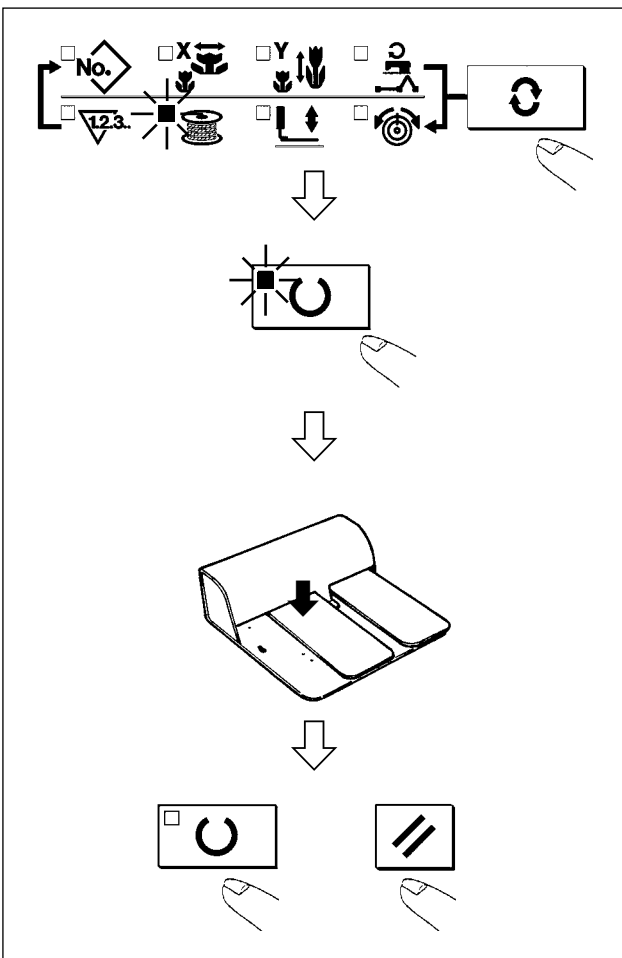

- 1) Press key to make the SEWING LED go off.
- 2) Select the bobbin winding with key.



**Caution** Selection cannot be performed when the Sewing LED is lit up.





- 3) Press key. The work clamp feet come down and the Sewing LED lights up.
- 4) When the pedal switch is depressed, the sewing machine rotates.
- 5) When the pedal is depressed again, or key or key is pressed, the sewing machine stops. When winding bobbin ends with key, the winding bobbin mode is completed.
- 6) When key is pressed, the Sewing LED goes off, the work clamp feet go up and key becomes effective.

### 3-7. Operation of CP-20 (Advanced)

#### (1) Performing sewing using the pattern keys ( , , , and )

When registering the patterns already registered (No. 1 to 200) to P1 to P25, calling of the pattern can be performed with one-touch without selecting by scrolling of pattern No.

It is possible to change and register enlargement/reduction ratio, max. speed limitation, thread tension, and sewing position.

\* When selecting P6 to P25, perform the selection by combination of  ,  ,  ,  and  keys as shown in the table below.

P-No.	Selection key	P-No.	Selection key	P-No.	Selection key	P-No.	Selection key
P1	P1	P8	P1+P4	P15	P4+P5	P22	P2+P3+P4
P2	P2	P9	P1+P5	P16	P1+P2+P3	P23	P2+P3+P5
P3	P3	P10	P2+P3	P17	P1+P2+P4	P24	P2+P4+P5
P4	P4	P11	P2+P4	P18	P1+P2+P5	P25	P3+P4+P5
P5	P5	P12	P2+P5	P19	P1+P3+P4		
P6	P1+P2	P13	P3+P4	P20	P1+P3+P5		
P7	P1+P3	P14	P3+P5	P21	P1+P4+P5		



#### (2) Register to the pattern key

Setting example : Register following setting to the P2., Pattern No. 3, X scale rate : 50%, Y Scale rate : 80%, Max. speed limitation : 2,000 rpm, Thread tension : "50", Pattern position : 0.5 mm to the right and 1 mm to the front





- ← 1) Turn ON the power switch and press  key to enter mode setting (memory switch setting). (Sewing LED should be put out.)







- ← 2) Indicate the pattern register mode with  or  key.



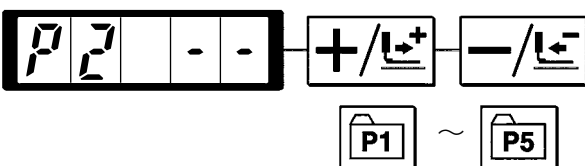



- ← 3) Press  key.  
Enter the pattern register mode.

 **When the space after P1 is blank, the data is in the registered state. When the space after P1 is "- -", the data is not in the registered state.**



- ← 4) Press  key. (Select P-No. to be registered.) Selection can be performed with  or  key.



- ← 5) Press  key to indicate the Pattern No. . Set the Pattern No. to "3" with  or  key.



6) Press key and set as follows with or key.

• X Scale rate : “50.0”%,

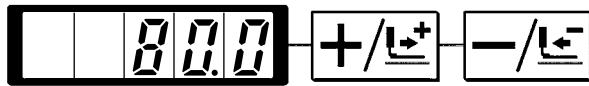

• Y Scale rate : “80.0”%,

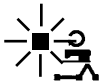

• Max. speed limitation : “2000” rpm,

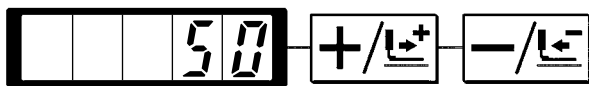
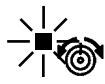

• Thread tension : “50”

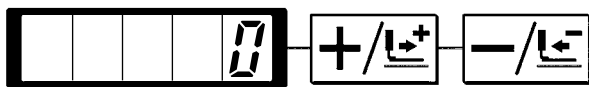
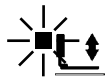

• Presser height : “0”

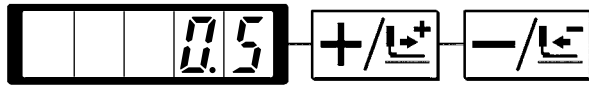

7) Press key and “X Scale rate ” indication becomes 0.0. Traveling amount in X direction can be set in 0.1 mm unit. Set 0.5 with or key.

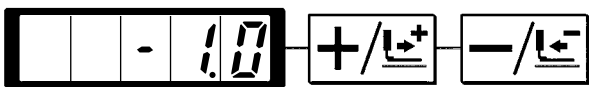

8) Press key and “Y Scale rate ” indication becomes 0.0. Traveling amount in Y direction can be set in 0.1 mm unit. Set -1.0 with or key.

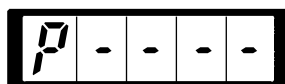

9) Press key.  
Data is determined, and the pattern register mode ends. When key is pressed, the set data is canceled.

10) Press key.  
Mode setting is finalized and the mode returns to the normal mode.

### (3) Sewing operation

Operation example : After performing sewing with the contents of the registered P2, perform sewing with the contents of P3.

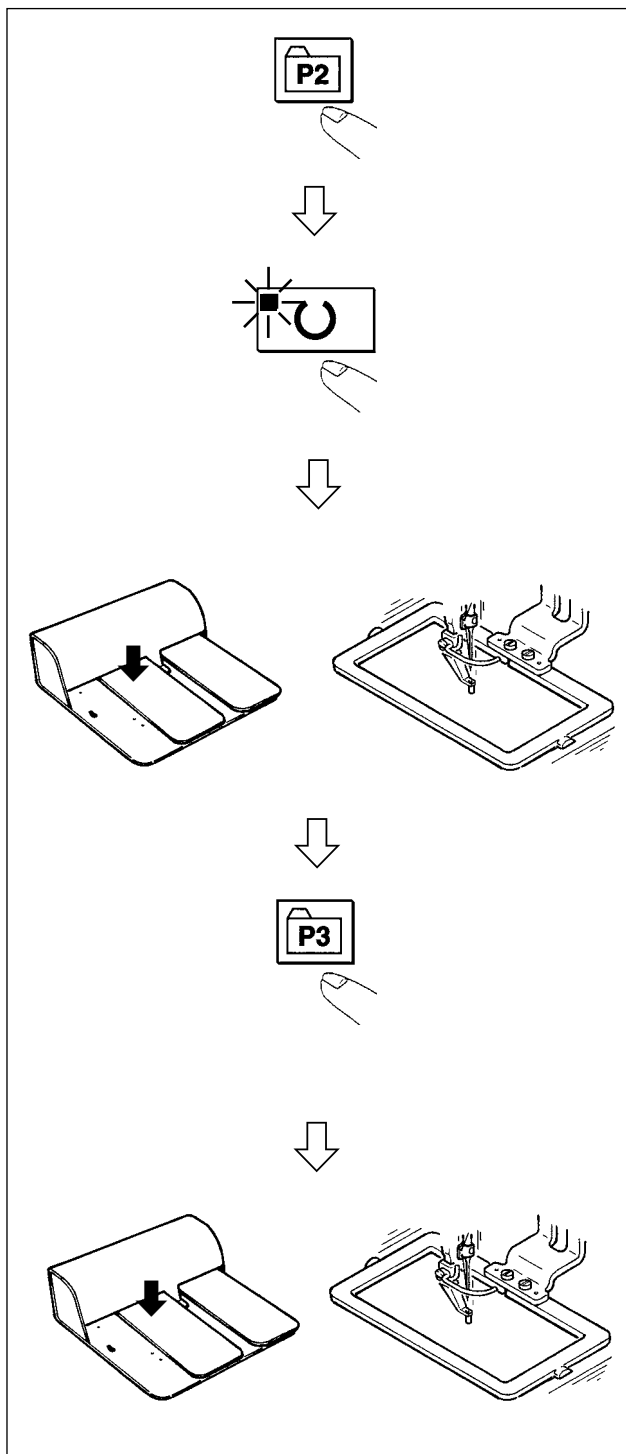

- 1) Turn ON the power switch.
  - 2) Press the **P2** key.
  - 3) Press the **U** key, and when the sewing LED lights up, the work clamp foot goes up after it has moved.
  - 4) Check the contour of the sewing pattern. (Refer to the item “**II-3-2.(2) Checking the contour of a sewing pattern**” p.87.)
  - 5) If the contour of the sewing pattern is acceptable, the sewing can be made.
  - 6) Press **P3** key after completion of sewing and the presser comes down. The presser moves to the sewing start point after origin retrieval and goes up. (The P keys can operate the pattern change by one-touch even when the sewing LED is lighting up.)
  - 7) Perform the above items 4) and 5).
- \* The P1 to P50 can be indicated on the display when selecting the pattern by pressing the **+/-** or **-/+** key.

→ 0 → S1 to S999 → 1 to 200 → P1 to P50

P1 to P50 which have not been registered are not indicated.

### 3-8. Performing sewing using the combination function

By arranging in the order of use of the pattern register (P1 to P25) which have been already registered and registering in C1 to C20, the sewing pattern will change in the order every time the sewing machine finishes the sewing.

#### (1) Register of the combination

Setting example : Combine in the order of P1, P2 and P3, and register them in the C1.



- 1) Turn ON the power switch and press **M** key to enter the mode setting (memory switch setting).



- 2) Indicate the combination mode with **+/-** or **-/-** key.

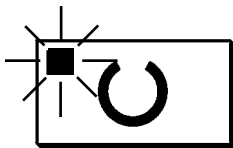

- 3) Press **U** key. Sewing LED lights up to enter the combination mode. C1 to C20 can be selected with **+/-** or **-/-** key.



**Reference**  
When the space after C1 is blank, the data is in the registered state. When the space after C1 is "- -", the data is not in the registered state.



- 4) Press **C** key, and then press **P1** key. P1 is set to the first pattern of C1.



- 5) Press **C** key, and then press **P2** key. P2 is set to the second pattern of C1.



- 6) Press **C** key, and then press **P3** key. P3 is set to the third pattern of C1.

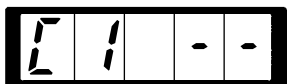

- 7) Press **U** key to finalize the register.

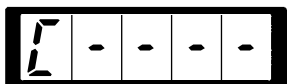

- 8) Press **M** key. Combination register mode is finalized.

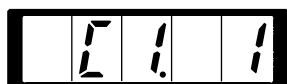

- 9) Press **M** key. Mode setting is finalized and the mode returns to the normal mode.

## (2) Sewing operation

Operation example : Perform sewing with the contents of the registered C1.

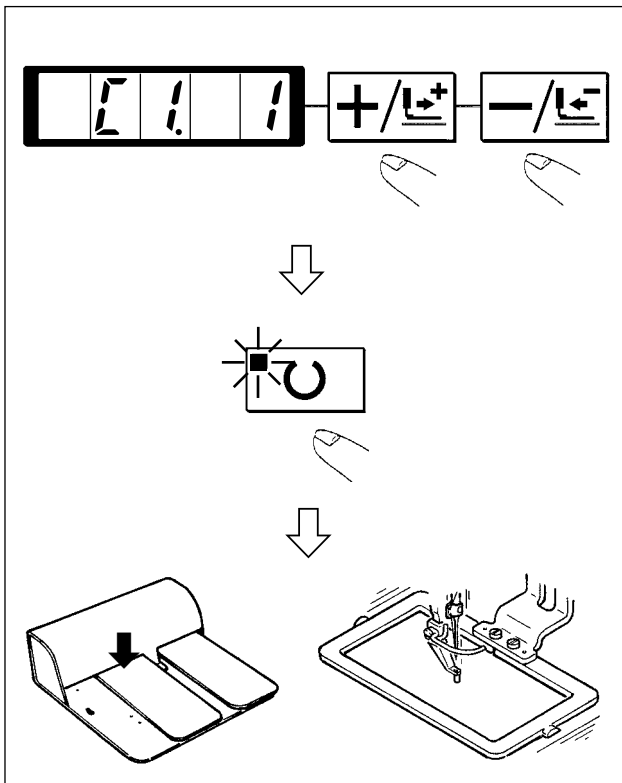

- 1) Turn ON the power switch.
- 2) Set the pattern No. to "C1-1" using the  $\boxed{+/\text{L}^+}$  or  $\boxed{-/\text{L}^-}$  key. Scroll as follows :

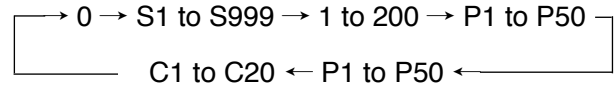

- 3) Press the  $\boxed{\text{U}}$  key. When the sewing LED lights up, the work clamp feet will go up after having moved.
- 4) If the contour of the pattern is acceptable, the sewing can be made.
- 5) Every time the sewing is finished, the step is made in the order of the combination. After completing one cycle of sewing, the step returns to the first step. The sewing can be made repeatedly.



Reference

1. When you desire to return the pattern to the previous one or skip the next pattern after sewing, press  $\boxed{+/\text{L}^+}$  or  $\boxed{-/\text{L}^-}$  key in a state that the sewing LED lights up. The indication of the pattern will change, and the work clamp feet will move to the sewing start point.
2. If the contents of P1 to P25 are changed after registration of C1 to C20, the contents of P1 to P25 used in C1 to C20 will change. So, be careful.
3. Make sure of the contour of the pattern for each of the patterns. (Refer to the item "II-3-2.(2) Checking the contour of the sewing pattern" p.87.)

### 3-9. When using as "bobbin thread counter"

The production counter can be used as the bobbin thread counter. In case a same sewing pattern is sewn in repetition, the sewing machine will stop sewing when the number of times (the specified number) that can be sewn with a bobbin is reached. The bobbin thread counter is of the subtracting method.



The counter at the time of delivery is set to the production counter (adding method). If it is used as the bobbin thread counter, it is necessary to change over memory switch. (Refer to the item "II-3-10. Start and change of the memory switch" p.100.)

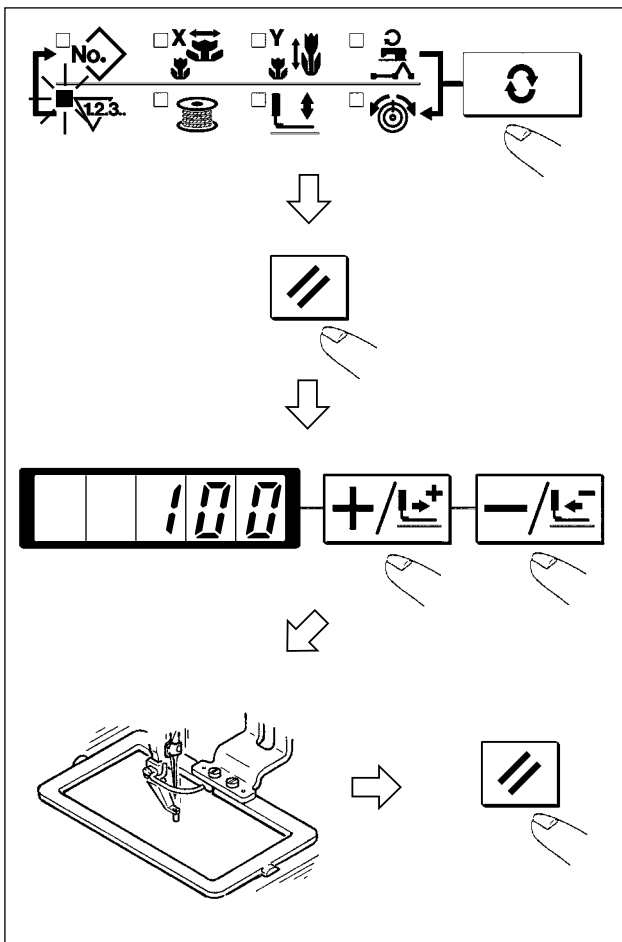

- 1) Press key while sewing LED goes off to indicate COUNTER display .
- 2) Then press the key.
- 3) Then press the or key, and set the specified number of times that can be sewn with a bobbin.
- 4) Every time the sewing machine finishes a sewing cycle, counting-down is made by one.
- 5) When the sewing machine finishes the specified number of times, the sewing machine does not start even if depressing the pedal.
- 6) Replace the bobbin with a new one, and press the key. The value of the counter returns to the set value.
- 7) Repeat the steps of procedure from the steps 4) to 6).

#### (1) How to use the temporary stop

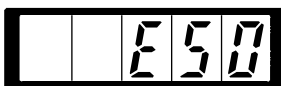

- 1) Sewing machine stops by TEMPORARY STOP switch of machine head.

Error 50 is indicated. Release the error with key.

- 2) There are three operations after stop as below.
  - ① Re-start of sewing by means of the start switch.
  - ② Press key to perform thread trimming, perform positioning with or key, and re-start by means of the start switch.
  - ③ Press key to perform thread trimming, and press again key to return to the origin.

### 3-10. Start and change of the memory switch

The sewing machine operation can be changed by changing the setting of the memory switch.

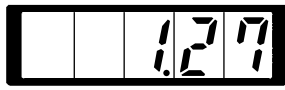

Three figures from the top are memory switch Nos.

Two figures from the bottom are contents of setting.

- 1) When **M** key is pressed in the state that the sewing LED is put out, the memory switch setting mode is obtained.

1.27 which is indicated when "M" key is pressed indicates that the max. speed limitation of the first memory switch is 2,700 rpm. (State at the time of delivery from the factory)





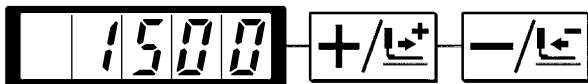







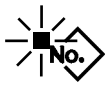
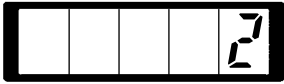



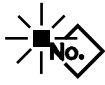

- 2) Change the memory switch No. with **+/-** or **-/-** key.

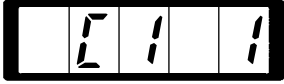



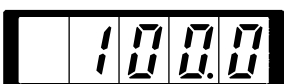
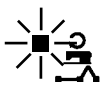
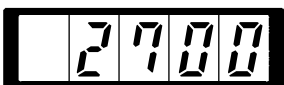

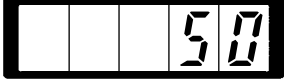
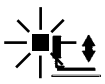
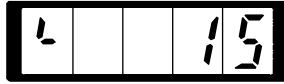
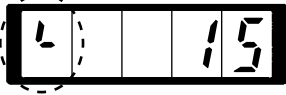
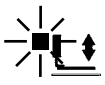

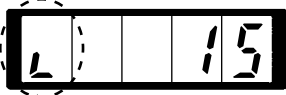

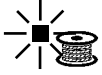
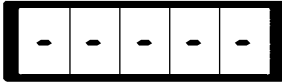
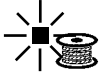
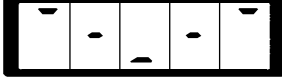
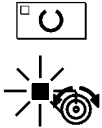
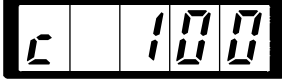
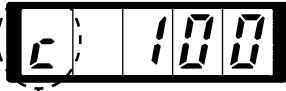
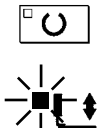









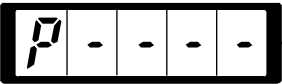
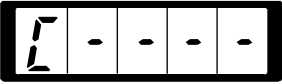





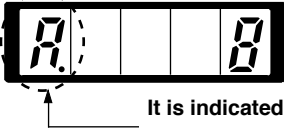

- 3) Adjust the memory switch No. to the No. you desire to change, and press **U** key. The sewing LED lights up.
- 4) Change the contents of the memory switch with **+/-** or **-/-** key.
- 5) The value can be returned to the value at the time of delivery from the factory with **⚡** key.
- 6) Press **U** key to register the contents of change. Sewing LED goes off and the mode returns to the selective state of the memory switch No.
- 7) Press **M** key to finalize the memory switch setting mode and the mode returns to the normal mode.

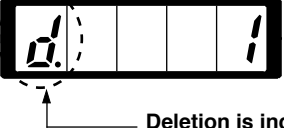
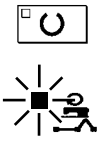

### 3-11. Correspondence table of LED and 7-segment display

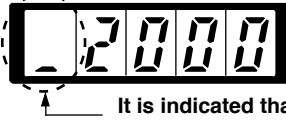
No.	Lit LED	7-segment display	Description
1			Data being read is displayed when turning ON the power.
2			Smart media pattern display Example) Smart media pattern 2
3			Smart media pattern display Example) Smart media pattern 3   Pattern in the smart media is indicated.
4			Pattern key display Example) Pattern key 1   Pattern key is indicated.
5			Cycle pattern Example) Cycle pattern 1   Cycle pattern 1 is indicated.      1st register
6			X enlargement/reduction ratio display Example) 100.0%
7			Y enlargement/reduction ratio display Example) 100.0%
8			Max. number of revolutions display Example) 2,700 rpm
9			Thread tension display Example) 50
10			Intermediate presser height (When presser goes up.) Example) 1.5mm   When presser goes up.
11			Intermediate presser height (When presser comes down.) Example) 1.5mm   When presser comes down.



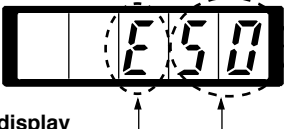









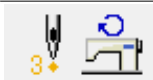

No.	Lit LED	7-segment display	Description
12			Bobbin winder (When presser goes up.)
13			Bobbin winder (When presser comes down.)
14			Thread tension command input position Example) 100  It is indicated that thread tension command is inputted in the current position.
15			Intermediate presser command input position Example) 1.5mm  It is indicated that intermediate presser command is inputted in the current position.
16			Smart media pattern, the contents of which are changed display Example) Smart media pattern 20  It is indicated that the pattern has been changed.
17			Confirmation display when changing No. of smart media pattern, the contents of which are changed
18			Overwriting confirmation and deletion confirmation display
19			Memory switch display Example) Memory switch No. 1, set value : 2700  Memory switch No. ____ Set value
20			Direct pattern register and edit display
21			Cycle pattern register and edit display
22			Copy
23			Deletion

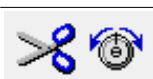
No.	Lit LED	7-segment display	Description
24			<p>When copy destination No. is set. Example) Users' pattern 8</p>  <p>It is indicated that pattern No. to be copied is being selected.</p>
25			<p>When copy destination No. which has been set already exists. Example) Users' pattern 200</p>  <p>It is indicated when copy destination pattern No. which has been set already exists.</p>
26			<p>Deletion No. selection Example) Users' pattern 1</p>  <p>Deletion is indicated.</p>
27		 	<p>Number of revolutions in the sewing state display It is possible to change the number of revolutions during sewing with <math>\boxed{+/\pm}</math> key or <math>\boxed{-/\pm}</math> key. (Change is temporary.) Example) Max. number of revolutions : 2,700 rpm</p>  <p>State of max. number of revolutions is indicated.</p> <p>Number of revolutions : 2,000 rpm</p>  <p>It is indicated that the number of revolutions has been changed from max. number of revolutions.</p>
28			<p>Counter value display Example) Counter value : 9999</p>
29			<p>Error No. display (Flash) Example) Error No. 50</p>  <p>Error display _____ Error No. _____</p>





## 4. MEMORY SWITCH DATA LIST







Memory switch data are the motion data that the sewing machine has in common and the data that operate on all sewing patterns in common.



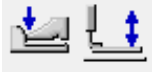





### 4-1. Data list

No.	Item		Setting range	Edit unit
U01	Maximum sewing speed		200 to 2700	100rpm
U02	Sewing speed of 1st stitch In case of with thread clamp		200 to 1500	100rpm
U03	Sewing speed of 2nd stitch In case of with thread clamp		200 to 2700	100rpm
U04	Sewing speed of 3rd stitch In case of with thread clamp		200 to 2700	100rpm
U05	Sewing speed of 4th stitch In case of with thread clamp		200 to 2700	100rpm
U06	Sewing speed of 5th stitch In case of with thread clamp		200 to 2700	100rpm
U07	Thread tension of 1st stitch In case of with thread clamp		0 to 200	1
U08	Thread tension setting at the time of thread trimming		0 to 200	1
U09	Thread tension changeover timing at the time of thread trimming		- 6 to 4	1
U10	Sewing speed of 1st stitch In case of without thread clamp		200 to 1500	100rpm
U11	Sewing speed of 2nd stitch In case of without thread clamp		200 to 2700	100rpm
U12	Sewing speed of 3rd stitch In case of without thread clamp		200 to 2700	100rpm
U13	Sewing speed of 4th stitch In case of without thread clamp		200 to 2700	100rpm
U14	Sewing speed of 5th stitch In case of without thread clamp		200 to 2700	100rpm
U15	Thread tension of 1st stitch In case of without thread clamp		0 to 200	1
U16	Thread tension changeover timing at the time of sewing start In case of without thread clamp		- 5 to 2	1

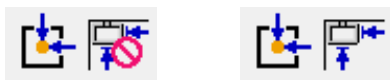
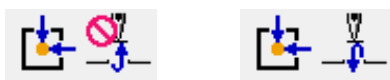

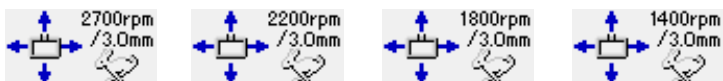

No.	Item	Setting range	Edit unit
	<b>Operation panel key lock mode (CP-20 only)</b> 0 : Normal 1 : X enlarging / Y enlarging / speed Item skip		
	<b>Counter motion selection (CP-20 only)</b> 0 : Sewing UP counter 1 : Bobbin thread DOWN counter		
U26	<b>Height of eight of presser at the time of 2 step scrolling</b> 	50 to 90	1
U32	<b>Buzzer sound can be prohibited.</b> 	---	---
U33	<b>Number of stitches of thread clamp release is set.</b> 	1 to 7	1
U34	<b>Clamping timing of thread clamp can be delayed.</b> 	- 10 to 0	1
U35	<b>Thread clamp control can be prohibited.</b> 	---	---
U36	<b>Feed motion timing is selected.</b> Set the timing in “-” direction when stitch is not well-tightened. 	- 8 to 16	1
U37	<b>State of the presser after end of sewing is selected.</b> 	---	---
U38	<b>Presser lifting motion at the end of sewing can be set.</b> 	---	---
U39	<b>Origin retrieval can be performed every time after end of sewing (other than combination sewing)</b> 	---	---
U40	<b>Origin retrieval in combination sewing can be set.</b> 	---	---
U41	<b>State of presser when sewing machine stops by temporary stop command can be selected.</b> 	---	---

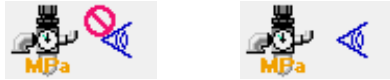
No.	Item	Setting range	Edit unit
U42	<b>Needle stop position is set.</b>  0 : UP position    1 : Upper dead point	---	---
U46	<b>Thread trimming can be prohibited.</b>  0 : Normal    1 : Thread trimming prohibited	---	---
U48	<b>Route of return to origin by return to origin button can be selected.</b>  0 : Linear return    1 : Reverse return of pattern    2 : Origin retrieval → Sewing start point	---	---
U49	<b>Bobbin winding speed can be set.</b> 	800 to 2000	100rpm
U51	<b>Motion method of wiper can be selected.</b>  0 : Invalid    1 : Magnet typewriter	---	---
U64	<b>Unit of sewing shape size change can be selected.</b> <b>Function for IP-410 only</b>  0 : %input    1 : Actual size input	---	---
U68	<b>Thread tension output time when setting thread tension can be set.</b> 	0 to 20	1
U69	<b>Bend position of thread clamp is selected.</b> 0 : 0 : S type 1 : H type thin thread (#50 to #8) 2 : H type intermediate 3 : H type thick thread (#5 to #2) 	---	---
U70	<b>Thread clamp and thread clamp position selection</b>  0 : Standard (Front position)    1 : Rear position	---	---
U71	<b>Thread breakage detection selection</b>  0 : Thread breakage detection invalid    1 : Thread breakage detection valid	---	---
U72	<b>Number of invalid stitches at the start of sewing of thread breakage detection</b> 	0 to 15 stitches	1 stitch
U73	<b>Number of invalid stitches during sewing of thread breakage detection</b> 	0 to 15 stitches	1 stitch

No.	Item	Setting range	Edit unit
U81	<p><b>Feeding frame control : pedal open/close</b></p>  <p>(At the time of control by motor)</p> <ul style="list-style-type: none"> <li>0 : 1-step</li> <li>1 : 2-step stroke (Lowering again with presser switch)</li> <li>2 : 2-step stroke (Starting re-lowering with start switch)</li> <li>3 : 3-step stroke (Intermediate → re-lowering → lifting with presser switch 1)</li> <li>4 to 99 : 1-step</li> </ul> <p>(At the time of control by air)</p> <ul style="list-style-type: none"> <li>0 : Solid presser</li> <li>1 : Right/left separated presser (Without priority of right/left)</li> <li>2 : Right/left separated presser (In the order of right to left)</li> <li>3 : Right/left separated presser (In the order of left to right)</li> <li>4 : Solid stroke</li> <li>5 : Right/left separated left stroke (Without priority of right/left)</li> <li>6 : Right/left separated left stroke (In the order of right to left)</li> <li>7 : Right/left separated left stroke (In the order of left to right)</li> <li>8 to 99 : Solid presser</li> </ul>	0 to 99	1
U82	<p><b>Feeding frame control : midway stop time open/close</b></p>  <p>(At the time of control by motor)</p> <ul style="list-style-type: none"> <li>0 : 1-step</li> <li>1 : 2-step stroke (Lowering again with presser switch)</li> <li>2 : 2-step stroke (Starting re-lowering with start switch)</li> <li>3 : 3-step stroke (Intermediate → re-lowering → lifting with presser switch 1)</li> <li>4 to 99 : 1-step</li> </ul> <p>(At the time of control by air)</p> <ul style="list-style-type: none"> <li>0 : Solid presser</li> <li>1 : Right/left separated presser (Without priority of right/left)</li> <li>2 : Right/left separated presser (In the order of right to left)</li> <li>3 : Right/left separated presser (In the order of left to right)</li> <li>4 : Solid stroke</li> <li>5 : Right/left separated left stroke (Without priority of right/left)</li> <li>6 : Right/left separated left stroke (In the order of right to left)</li> <li>7 : Right/left separated left stroke (In the order of left to right)</li> <li>8 to 99 : Solid presser</li> </ul>	0 to 99	1
U84	<p><b>Pedal SW1 with/without latch</b></p>  <p>0 : Without      1 : With</p>	---	---
U85	<p><b>Pedal SW2 with/without latch</b></p>  <p>0 : Without      1 : With</p>	---	---
U86	<p><b>Pedal SW3 with/without latch</b></p>  <p>0 : Without      1 : With</p>	---	---
U87	<p><b>Pedal SW4 with/without latch</b></p>  <p>0 : Without      1 : With</p>	---	---

No.	Item	Setting range	Edit unit
U88	<b>Enlarging/reducing function mode</b> (CP-20 : increasing/decreasing of pitch only)  0 : Prohibited    1 : Increasing/decreasing number of stitches (Pitch is fixed.)    2 : Increasing/decreasing pitch (Number of stitches is fixed.)	---	---
U89	<b>Jog move function mode</b>  0 : Prohibited    1 : Parallel move    2 : 2nd origin specified later	---	---
U91	<b>Retainer compensation motion : selection of motion</b>  0 : Without motion    1 : With motion	---	---
U94	<b>Selection of needle upper dead point at the time of origin retrieval/return to origin</b>  0 : Without    1 : With	---	---
U97	<b>Temporary stop : thread trimming operation</b>  0 : Automatic thread trimming    1 : Manual (Thread trimming by turning Stop SW ON again)	---	---
U101	<b>Main motor X/Y feed synchronized control : speed/pitch</b>  0 : 2700rpm/ 3.0mm    1 : 2200rpm/ 3.0mm    2 : 1800rpm/ 3.0mm    3 : 1400rpm/ 3.0mm	---	---
U103	<b>Intermediate presser with/without control</b>  0 : Without (Lowering fixed)    1 : With (Lowering with sewing data at the time of operation)    2 : With (Lowering even at the time of feed forward/backward)	---	---
U104	<b>Intermediate presser lowering timing</b>  0 : Immediately before start-up of machine head    1 : Synchronized with the last feeding frame	---	---
U105	<b>Intermediate presser : wiper sweeping position</b>  0 : Sweeping above intermediate presser    1 : Sweeping above intermediate presser (position where intermediate presser lowers most)    2 : Sweeping below intermediate presser	---	---
U108	<b>With/without air pressure detection</b>  0 : Without    1 : With	---	---



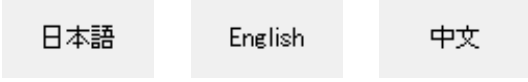





No.	Item	Setting range	Edit unit
U112	<b>Intermediate presser DOWN position setting</b> → Refer to <b>" I -4-7. Intermediate presser height" p.21.</b> 	0 to 7.0mm	0.1
U129	<b>With/without needle cooler control</b>   0 : Without                      1 : With	---	---
U245	<b>Grease-up error</b> Clearing of number of stitches of grease-up is performed. → Refer to <b>"Ⅲ-1-12 Replenishing the designated places with grease" p.128.</b> 	---	---
U500	<b>Language selection</b>  0 : Japanese      1 : English      2 : Chinese		



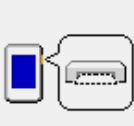

## 4-2. Initial value list

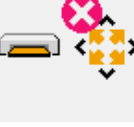





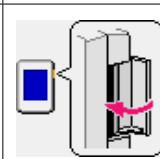
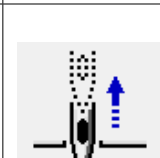
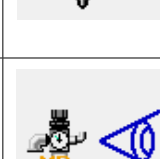
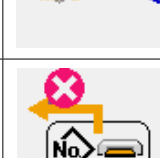
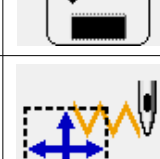

No.	Item	Initial value				
		SS/HS 1306	SL/HL 1306	SL/HL 1510	SL/HL 2206	SL/HL 2210
U01	Maximum sewing speed	2700				
U02	Sewing speed of 1st stitch (In case of with thread clamp)	1500				
U03	Sewing speed of 2nd stitch (In case of with thread clamp)	2700				
U04	Sewing speed of 3rd stitch (In case of with thread clamp)	2700				
U05	Sewing speed of 4th stitch (In case of with thread clamp)	2700				
U06	Sewing speed of 5th stitch (In case of with thread clamp)	2700				
U07	Thread tension of 1st stitch (In case of with thread clamp)	200				
U08	Thread tension setting at the time of thread trimming	0				
U09	Thread tension changeover timing at the time of thread trimming	0				
U10	Sewing speed of 1st stitch (In case of without thread clamp)	200				
U11	Sewing speed of 2nd stitch (In case of without thread clamp)	600				
U12	Sewing speed of 3rd stitch (In case of without thread clamp)	1000				
U13	Sewing speed of 4th stitch (In case of without thread clamp)	1500				
U14	Sewing speed of 5th stitch (In case of without thread clamp)	2000				
U15	Thread tension of 1st stitch (In case of without thread clamp)	0				
U16	Thread tension changeover timing at the time of sewing start (In case of without thread clamp)	-5				
	Operation panel key lock mode (CP-20 only)	0				
	Counter motion selection (CP-20 only)	0				
U26	Height of eight of presser at the time of 2 step scrolling	70				
U32	Buzzer sound can be prohibited.	2				
U33	Number of stitches of thread clamp release is set.	2				
U34	Clamping timing of thread clamp can be delayed.	0				
U35	Thread clamp control can be prohibited.	0				
U36	Feed motion timing is selected.	3				
U37	State of the presser after end of sewing is selected.	0				
U38	Presser lifting motion at the end of sewing can be set.	0				
U39	Origin retrieval can be performed every time after end of sewing (other than combination sewing).	0				
U40	Origin retrieval in combination sewing can be set.	0				
U41	State of presser when sewing machine stops by temporary stop command can be selected.	0				
U42	Needle stop position is set.	0				

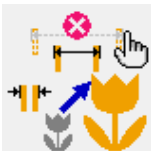

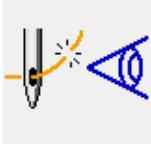

No.	Item	Initial value				
		SS/HS 1306	SL/HL 1306	SL/HL 1510	SL/HL 2206	SL/HL 2210
U46	Thread trimming can be prohibited.	0				
U48	Route of return to origin by return to origin button can be selected.	0				
U49	Bobbin winding speed can be set.	1600				
U51	Motion method of wiper can be selected.	1				
U64	Unit of sewing shape size change can be selected. Function for IP-410 only	0				
U68	Thread tension output time when setting thread tension can be set.	0				
U69	Bend position of thread clamp is selected.	S type : 0 / H type : 1				
U70	Thread clamp and thread clamp position selection	0				
U71	Thread breakage detection selection	1				
U72	Number of invalid stitches at the start of sewing of thread breakage detection	8				
U73	Number of invalid stitches during sewing of thread breakage detection	3				
U81	Feeding frame control : pedal open/close	0	1	0		
U82	Feeding frame control : midway stop time open/close	0	1	0		
U84	Pedal SW1 with/without latch	1				
U85	Pedal SW2 with/without latch	1				
U86	Pedal SW3 with/without latch	1				
U87	Pedal SW4 with/without latch	1				
U88	Enlarging/reducing function mode (CP-20 : increasing/decreasing of pitch only)	1				
U89	Jog move function mode	2				
U91	Retainer compensation motion : selection of motion	0				
U94	Selection of needle upper dead point at the time of origin retrieval/return to origin	0				
U97	Temporary stop : thread trimming operation	1				
U101	Main motor X/Y feed synchronized control : speed/pitch	0				
U103	Intermediate presser with/without control	1				
U104	Intermediate presser lowering timing	0				
U105	Intermediate presser : wiper sweeping position	1				
U108	With/without air pressure detection	0	1			
U112	Intermediate presser DOWN position setting	3.5				
U129	With/without needle cooler control	1				
U245	Grease-up error	-				
U500	Language selection	1				

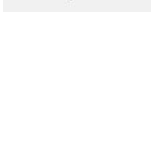



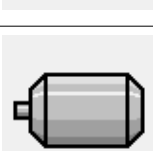
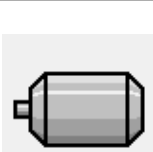
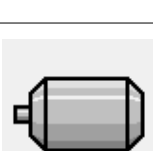
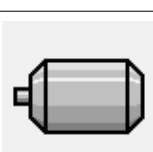

## 5. ERROR CODE LIST

Error code	Display	Description of error	Display message	How to recover	Place of recovery
E007		<b>Machine lock</b> Main shaft of the sewing machine fails to rotate due to some trouble	Pattern data no good.	Turn OFF the power	
E008		<b>Head connector abnormality</b> Memory of machine head cannot be read.	Undefined head is selected.	Turn OFF the power	
E010		<b>Pattern No. error</b> Pattern No. which is backed up is not registered to data ROM, or setting of reading inoperative is performed.	Specified pattern does not exist.	Possible to re-enter after reset.	Previous screen
E011		<b>External media not inserted</b> External media is not inserted.	Media is not inserted.	Possible to re-enter after reset.	Previous screen
E012		<b>Read error</b> Data read from external media cannot be performed.	Data cannot be read.	Possible to re-start after reset.	Previous screen
E013		<b>Write error</b> Data write from external media cannot be performed.	Data cannot be written.	Possible to re-start after reset.	Previous screen
E015		<b>Format error</b> Format cannot be performed.	Formatting is impossible.	Possible to re-start after reset.	Previous screen
E016		<b>External media capacity over</b> Capacity of external media is short.	Capacity is insufficient. (Media)	Possible to re-start after reset.	Previous screen
E017		<b>EEPROM capacity over</b> Capacity of EEPROM is short.	Capacity is insufficient. (MAIN EEPROM)	Possible to re-start after reset.	Previous screen

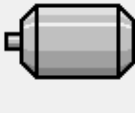
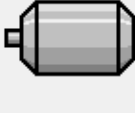

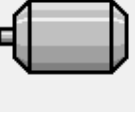
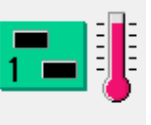

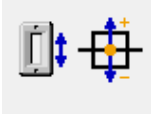
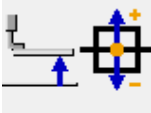

Error code	Display	Description of error	Display message	How to recover	Place of recovery
E018		<b>Type of is different.</b> When the mounted EEPROM is different in type.	ROM type is different.		Previous screen
E019		<b>File size over</b> File is too large.	Pattern data is too large. (Approx. 50,000 stitches)	Possible to re-start after reset.	Previous screen
E024		<b>Pattern data size over</b> Memory size is over.	Memory size to large.	Possible to re-start after reset.	Data input screen
E027		<b>Read error</b> Data read from server cannot be performed.	Data cannot be read.	Possible to re-start after reset.	Previous screen
E028		<b>Write error</b> Data write from server cannot be performed.	Data cannot be written.	Possible to re-start after reset.	Previous screen
E029		<b>Media slot release error</b> Lid of media slot is open.	Cover of Media slot is open.	Possible to re-start after reset.	Previous screen
E030		<b>Needle bar position missing error</b> Needle bar is not in the predetermined position.	Needle is not in a proper position.	Turn hand pulley to bring needle bar to its predetermined position.	Data input screen
E031		<b>Air pressure drop</b> Air pressure is dropped.	Low air pressure.	Possible to re-start after reset.	Data input screen
E032		<b>File interchanging error</b> File cannot be read.	File cannot be read.	Possible to re-start after reset.	Data input screen
E040		<b>Sewing area over</b>	Move limit is exceeded.	Possible to re-start after reset.	Sewing screen

Error code	Display	Description of error	Display message	How to recover	Place of recovery
E043		<b>Enlarging error</b> Sewing pitch exceeds Max. pitch.	Max. Pitch is exceeded.	Possible to re-start after reset.	Data input screen
E045		<b>Pattern data error</b>	Pattern data no good.	Possible to re-start after reset.	Data input screen
E050		<b>Stop switch</b> When stop switch is pressed during machine running.	Temporary stop switch is pressed.	Possible to re-start after reset.	Step screen
E052		<b>Thread breakage detection error</b> When thread breakage is detected.	Thread breakage is detected.	Possible to re-start after reset.	Step screen
E061		<b>Memory switch data error</b> Memory switch data is broken or revision is old.	Memory switch data error	Turn OFF the power	
E220		<b>Grease-up warning</b> At the time of operation of 100 million stitches → Refer to "III-1-12 Replenishing the designated places with grease" p.128.	Important : Grease is running out. Replace grease machine.	Possible to re-start after reset.	Data input screen
E221		<b>Grease-up error</b> At the time of operation of 120 million stitches The sewing machine is put in the sewing-impossible status. It is possible to clear with memoryswitch <b>L245</b> . → Refer to "III-1-12 Replenishing the designated places with grease" p.128.	Important : Grease has run out. Replace grease machine.	Possible to re-start after reset.	Data input screen
E302		<b>Head tilt confirmation</b> When head tilt sensor is OFF.	Head is tilted.	Possible to re-start after reset.	Previous screen
E305		<b>Cloth cutting knife position error</b> Cloth cutting knife is in the regular position.	Thread trimmer knife sensor cannot be detected.	Turn OFF the power	Data input screen

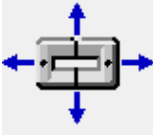



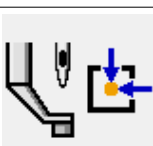

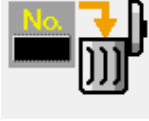
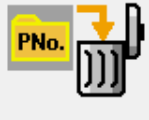

Error code	Display	Description of error	Display message	How to recover	Place of recovery
E306		<b>Thread clamp position error</b> Thread clamp unit is not in the regular position.	Thread clamp sensor cannot be detected.	Turn OFF the power	
E307		<b>External input command time out error</b> Input is not performed for a fixed period of time with the external input command of vector data.	There is no input for a certain period of time with external input command of vector data.	Possible to re-start after reset.	Data input screen
E308		<b>Time-out error of wait terminal</b> There is no input to wait terminal for a certain period of time.	There is no input from wait terminal for a certain period of time.	Turn OFF the power	
E703		<b>Panel is connected to the sewing machine which is not supposed. (Machine type error)</b> When the machine type code of system is not proper in the initial communication.	Model of sewing machine is different from that of panel.	Possible to rewrite program after pressing down communication switch.	Communication screen
E704		<b>Inconsistency of system version</b> System software version is inconsistent in the initial communication.	Version of program incompatible.	Possible to rewrite program after pressing down communication switch.	Communication screen
E730		<b>Main shaft motor encoder defectiveness</b> When encoder of the sewing machine motor is abnormal.	Sewing machine motor is defective. (Encoder A and B phases)	Turn OFF the power	
E731		<b>Main motor hole sensor is defective or position sensor is defective.</b> Hole sensor or position sensor of the sewing machine motor is defective.	Sewing machine motor is defective. (Encoder U, V, and W phases)	Turn OFF the power	
E733		<b>Reverse rotation of main shaft motor</b> When sewing machine motor rotates in reverse direction.	Sewing machine motor runs in the reverse direction.	Turn OFF the power	
E802		<b>Power electrical discontinuity detection</b>	Power instantaneously lost.	Turn OFF the power	

Error code	Display	Description of error	Display message	How to recover	Place of recovery
E811		<b>Overvoltage</b> When input power is more than the specified value.	Input voltage is too high. (Check input voltage.)	Turn OFF the power	
E813		<b>Low voltage</b> When input power is less than the specified value.	Input voltage is too low. (Check input voltage.)	Turn OFF the power	
E901		<b>Main shaft motor IPM abnormality</b> When IPM of servo control p.c.b. is abnormal.	SDC p.c.b. is defective. (IPM)	Turn OFF the power	
E903		<b>Stepping motor power abnormality</b> When stepping motor power of SERVO CONTROL p. c. b. fluctuates more than $\pm 15\%$ .	Power of SDC p.c.b. is defective. (Stepping motor power 85 V)	Turn OFF the power	
E904		<b>Solenoid power abnormality</b> When solenoid power of SERVO CONTROL p. c. b. fluctuates more than $\pm 15\%$ .	Power of SDC p.c.b. is defective. (Solenoid power 33 V)	Turn OFF the power	
E905		<b>Heat sink temperature for SERVO CONTROL p. c. b. abnormality</b> Turn ON the power again after taking overheat time of SERVO CONTROL p. c. b.	Temperature of SDC P.C.B is to high.	Turn OFF the power	
E907		<b>X feed motor origin retrieval error</b> When origin sensor signal is not inputted at the time of origin retrieval motion.	Origin of X motor cannot be found. (X origin sensor)	Turn OFF the power	
E908		<b>Y feed motor origin retrieval error</b> When origin sensor signal is not inputted at the time of origin retrieval motion.	Origin of Y motor cannot be found. (Y origin sensor)	Turn OFF the power	
E910		<b>Presser motor origin retrieval error</b> When origin sensor signal is not inputted at the time of origin retrieval motion.	Origin of presser thread trimmer motor cannot be found. (Presser thread trimmer origin sensor)	Turn OFF the power	
E913		<b>Thread clamp origin retrieval error</b> When origin sensor signal is not inputted at the time of origin retrieval motion.	Origin of thread clamp motor cannot be found. (Thread clamp origin sensor)	Turn OFF the power	





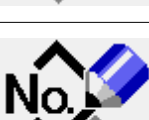

Error code	Display	Description of error	Display message	How to recover	Place of recovery
E914		<b>Feed defective error</b> Timing lag between feed and main shaft occurs.	X/Y feed trouble is detected.	Turn OFF the power	
E915		<b>Communication abnormality between operation panel and MAIN CPU</b> When abnormality occurs in data communication.	Communication is impossible. (Panel - MAIN p.c.b.)	Turn OFF the power	
E916		<b>Communication abnormality between MAIN CPU and main shaft CPU</b> When abnormality occurs in data communication.	Communication is impossible. (MAIN p.c.b. - Sewing machine motor p.c.b.)	Turn OFF the power	
E917		<b>Communication failure between operation panel and personal computer</b> When abnormality occurs in data communication.	Communication is impossible. (Panel - PC)	Possible to re-start after reset.	
E918		<b>MAIN p. c. b. overheat</b> Overheat of MAIN p. c. b. Turn ON the power again after taking time.	Main p.c.b temperature to high.	Turn OFF the power	
E925		<b>Intermediate presser motor origin retrieval error</b> Origin sensor of intermediate presser motor does not change at the time of origin retrieval.	Origin of intermediate presser cannot be found. (Intermediate presser origin sensor)	Turn OFF the power	
E943		<b>Defective EEPROM of MAIN CONTROL p. c. b.</b> When data writing to cannot be performed.	MAIN p.c.b. is defective. (EEPROM)	Turn OFF the power	
E946		<b>Defective EEPROM writing of HEAD RELAY p. c. b.</b> When data writing to cannot be performed.	Head p.c.b. is defective. (EEPROM writing is defective.)	Turn OFF the power	

## 6. MESSAGE LIST

Message No.	Display	Display message	Description
M520		Erasing is performed. OK ?	<b>Erase confirmation of Users' pattern</b> Erase is performed. OK ?
M521		Erasing is performed. OK ?	<b>Erase confirmation of pattern button</b> Erase is performed. OK ?
M522		Erasing is performed. OK ?	<b>Erase confirmation cycle pattern</b> Erase is performed. OK ?
M523		Pattern data is not stored. Erasing is OK?	<b>Erase confirmation of backup data</b> Pattern data is not stored in memory. Erase is OK ?
M528		Overwriting is performed. OK ?	<b>Overwriting confirmation of users' pattern</b> Overwriting is performed. OK ?
M529		Overwriting is performed. OK ?	<b>Overwriting confirmation of media</b> Overwriting is performed. OK ?
M530		Overwriting is performed. OK ?	<b>Overwriting confirmation of vector data of panel/M3 data/sewing standard format data/simplified program data</b> Overwriting is performed. OK ?
M531		Overwriting is performed. OK ?	<b>Overwriting confirmation of vector data of media/M3 data/sewing standard format data/simplified program data</b> Overwriting is performed. OK ?
M532		Overwriting is performed. OK ?	<b>Overwriting confirmation of vector data on personal computer/M3 data/sewing standard format data/simplified program data</b> Overwriting is performed. OK ?
M534		Overwriting is performed. OK ?	<b>Overwriting confirmation of adjustment data of media and all machine data</b> Overwriting is performed. OK ?

Message No.	Display	Display message	Description
M535		Overwriting is performed. OK ?	<b>Overwriting confirmation of adjustment data on personal computer and all machine data</b> Overwriting is performed. OK ?
M537		Deleting is performed. OK ?	<b>Deletion confirmation of thread tension command</b> Deleting is performed. OK ?
M538		Deleting is performed. OK ?	<b>Deletion confirmation of intermediate presser increase/decrease value</b> Deleting is performed. OK ?
M542		Formatting is performed. OK ?	<b>Format confirmation</b> Formatting is performed. OK ?
M544		Data does not exist.	<b>Data corresponding to panel does not exist.</b> Data does not exist.
M545		Data does not exist.	<b>Data corresponding to media does not exist.</b> Data does not exist.
M546		Data does not exist.	<b>Data corresponding to personal computer does not exist.</b> Data does not exist.
M547		Overwriting cannot be performed since data exists.	<b>Overwriting prohibition on pattern data</b> Overwriting cannot be performed since data exists.
M548		Overwriting cannot be performed since data exists.	<b>Overwriting prohibition on media data</b> Overwriting cannot be performed since data exists.
M549		Overwriting cannot be performed since data exists.	<b>Overwriting prohibition on data on personal computer</b> Overwriting cannot be performed since data exists.
M550		There is back-up data of body input.	<b>Backup data information on main body input</b> There is back-up data of body input.

Message No.	Display	Display message	Description
M653		Formatting is performed.	<b>During formatting</b> Formatting is performed.
M669		Data is being read.	<b>During data reading</b> Data is being read.
M670		Data is being written.	<b>During data writing</b> Data is being written.
M671		Data is being converted.	<b>During data converting</b> Data is being converted.

# III. MAINTENANCE OF SAWING MACHINE

## 1. MAINTENANCE

### 1-1. Adjusting the height of the needle bar (Changing the length of the needle)



**WARNING :**

Turn OFF the power before starting the work so as to prevent accidents caused by abrupt start of the sewing machine.

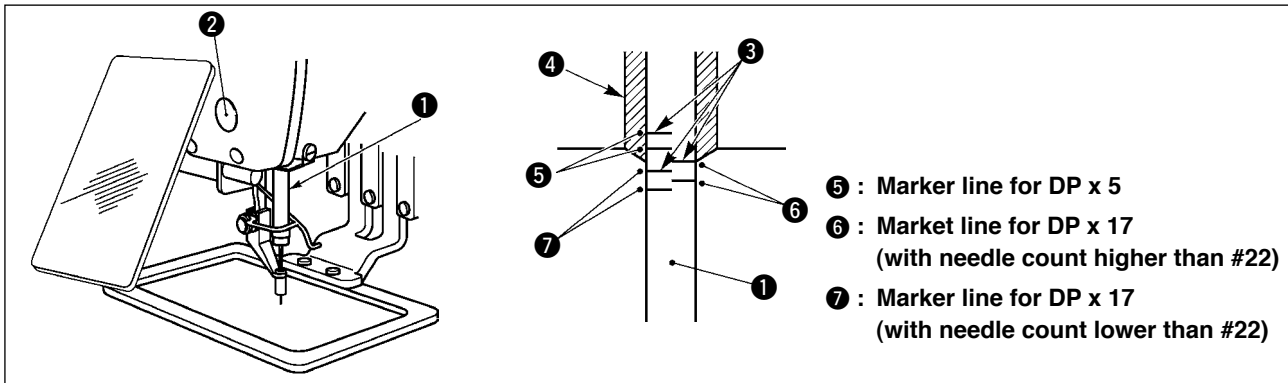

\* Turn ON the power once, and turn OFF the power again after making the intermediate presser in the lowered state.

- 1) Bring needle bar ① down to the lowest position of its stroke. Loosen needle bar connection screw ② and adjust so that the upper marker line ③ engraved on the needle bar aligns with the bottom end of the needle bar bushing lower ④.
- 2) As illustrated in the above figure, change the adjusting position in accordance with the needle count.



After the adjustment, turn the pulley to check for an extra load.

### 1-2. Adjusting the needle-to-shuttle relation



**WARNING :**

Turn OFF the power before starting the work so as to prevent accidents caused by abrupt start of the sewing machine.

Relation between the needle and the marker lines on the needle bar

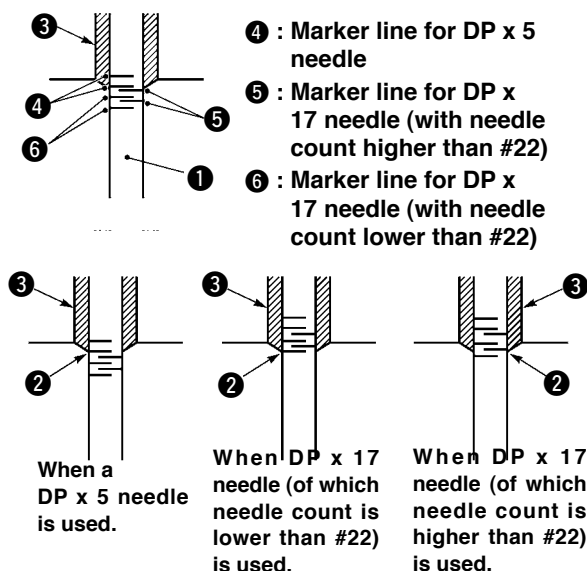

\* Turn ON the power once, and turn OFF the power again after making the intermediate presser in the lowered state.

- 1) Turn handwheel by hand to ascend the needle bar ①. Adjust so that lower marker line ② on the ascending needle bar aligns with the bottom end of the needle bar bushing lower.

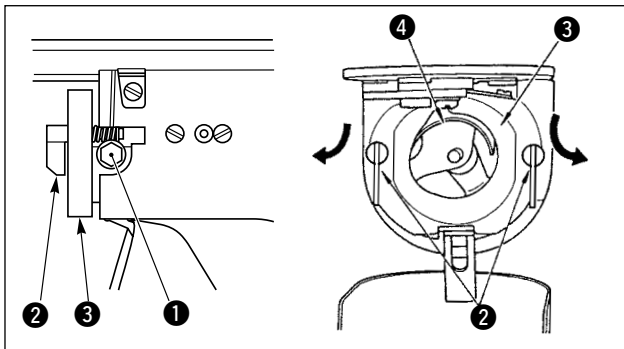

- 2) Loosen setscrew ① in the driver. Drawing bobbin case opening lever hook ② toward you, open it to the right and left until bobbin case opening lever ③ comes off.

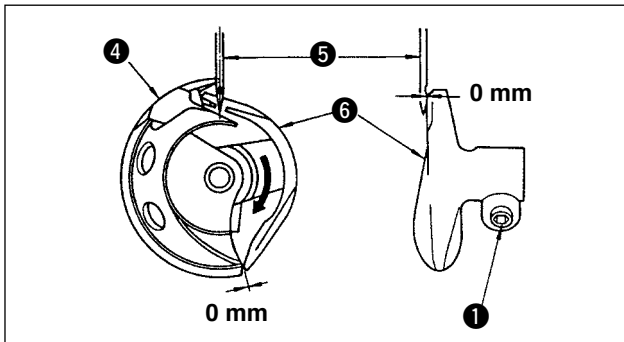
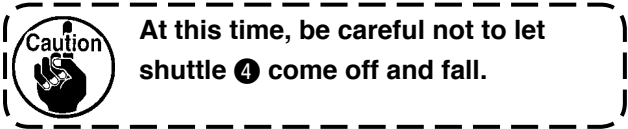

- 3) Adjust so that the point of shuttle ④ meets the center of needle ⑤, and that a clearance of 0 mm is provided between the front end face of driver ⑥ and needle as the front end face of driver receives needle to prevent the needle from being bent. Then tighten setscrew ①.

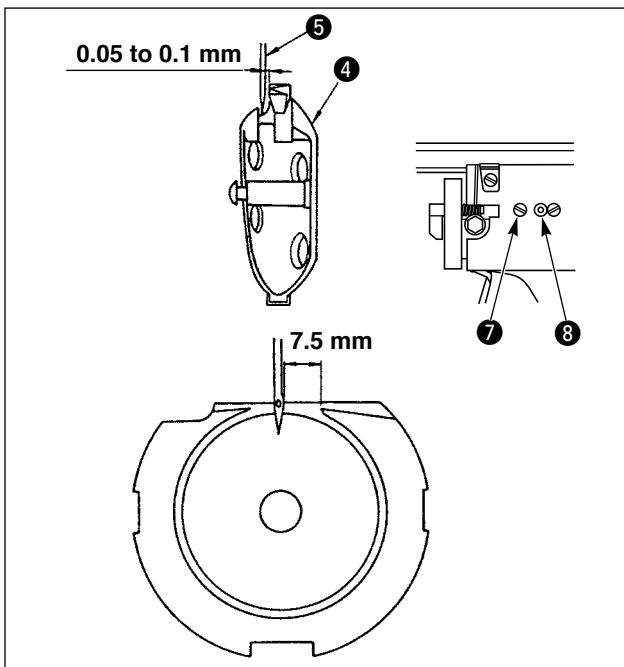

- 4) Loosen shuttle race screw ⑦, and adjust the longitudinal position of the shuttle race. To do this adjustment, turn shuttle race adjusting shaft ⑧ clockwise or counterclockwise to provide a 0.05 to 0.1 mm clearance between needle ⑤ and the blade point of shuttle ④.
- 5) After adjusting the longitudinal position of shuttle race, further adjust to provide a 7.5 mm clearance between the needle and the shuttle race. Then, tighten screw ⑦ of shuttle race.

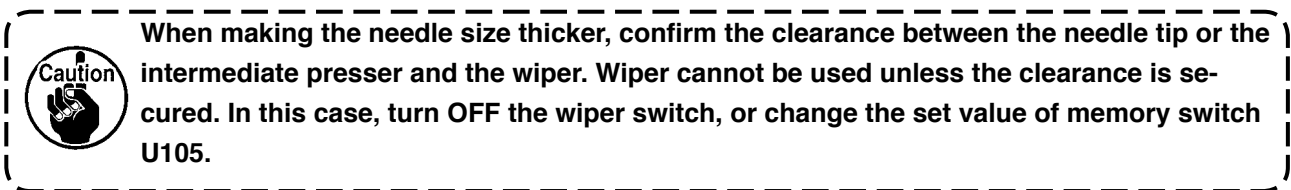

### 1-3. Adjusting the height of the feeding frame



**WARNING :**

Turn OFF the power before starting the work so as to prevent accidents caused by abrupt start of the sewing machine.

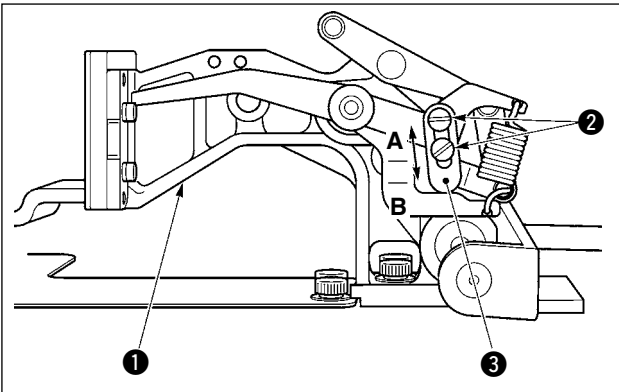

- 1) Loosen screws ② located on the right and left sides of feed bracket ①. Moving cloth presser stopper ③ to the direction B will increase the height of feeding frame.
- 2) After the adjustment of the height of the feeding frame, securely tighten the screws ②.

### 1-4. Adjusting the vertical stroke of the intermediate presser



**WARNING :**

Turn OFF the power before starting the work so as to prevent accidents caused by abrupt start of the sewing machine.

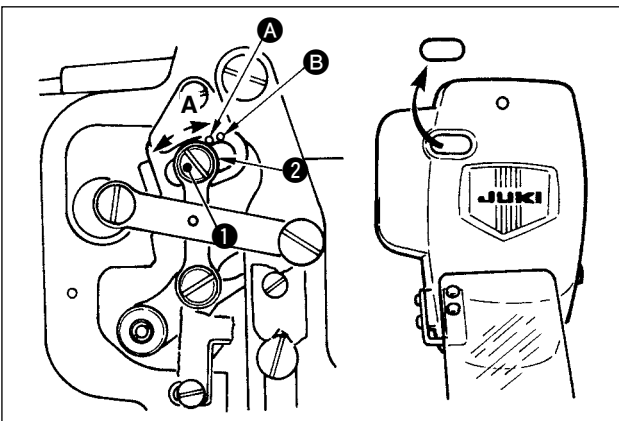

\* Turn ON the power once, and turn OFF the power again after making the intermediate presser in the lowered state.

- 1) Remove face cover.
- 2) Turn handwheel to make the needle bar come down to its lowest point.
- 3) Loosen hinge screw ① and move it to the direction A to increase the stroke.
- 4) When marker dot A is aligned with the right side of the outer periphery of washer ②, the vertical stroke of the intermediate presser becomes 4 mm. And, when marker dot B is aligned with the right side of the outer periphery of the washer, it becomes 7 mm. (The vertical stroke of the intermediate presser is factory-set to 4 mm at the time of delivery.)



By removing the rubber plug in the face plate cover, adjustment can be performed without removing the face plate cover.

## 1-5. The moving knife and counter knife



### WARNING :

Turn OFF the power before starting the work so as to prevent accidents caused by abrupt start of the sewing machine.

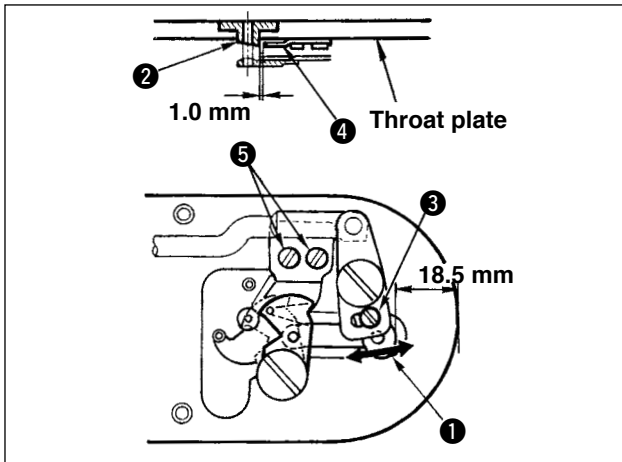

- 1) Loosen adjusting screw ① so that a clearance of 18.5 mm is provided between the front end of the throat plate and the top end of thread trimmer lever, small ③. To adjust, move the moving knife in the direction of arrow.
- 2) Loosen setscrew ⑤ so that a clearance of 1.0 mm is provided between needle hole guide ② and counter knife ④. To adjust, move the counter knife.

## 1-6. Needle thread clamp device



### WARNING :

Turn OFF the power before starting the work so as to prevent accidents caused by abrupt start of the sewing machine.

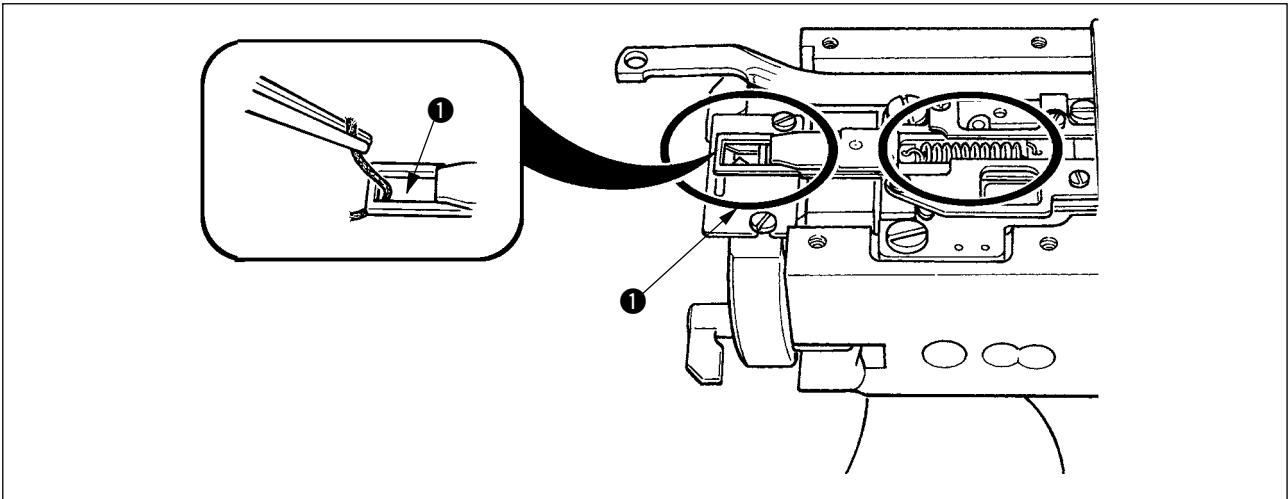

- 1) When thread is caught at top end ① of the thread clamp, thread clamp becomes incomplete and sewing trouble at the sewing start will be caused. Periodically remove and clean the throat plate since waste thread or thread dust is apt to gather in the places with circle mark.



### 1-7. Thread breakage detector plate

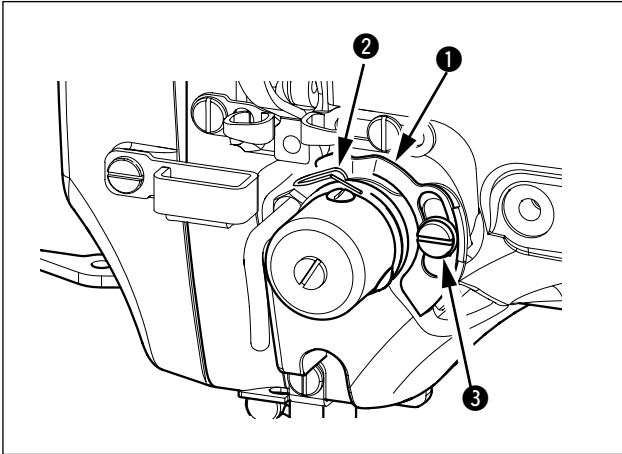

- 1) Adjust so that thread breakage detector plate ① is always in contact with thread take-up spring ② in the absence of needle thread. (Slack : approx. 0.5 mm)
- 2) Whenever the stroke of thread take-up spring ② has been changed, be sure to readjust thread breakage detector plate ①. To make this adjustment, loosen screw ③.



**Adjust so that thread breakage detector plate ① does not touch any adjacent metallic parts other than thread take-up spring ②.**

### 1-8. Draining waste oil

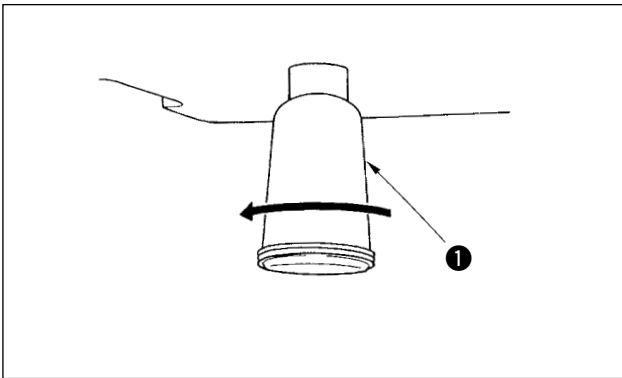

When polyethylene oiler ① becomes filled with oil, remove polyethylene oiler ① and drain the oil.

## 1-9. Amount of oil supplied to the hook

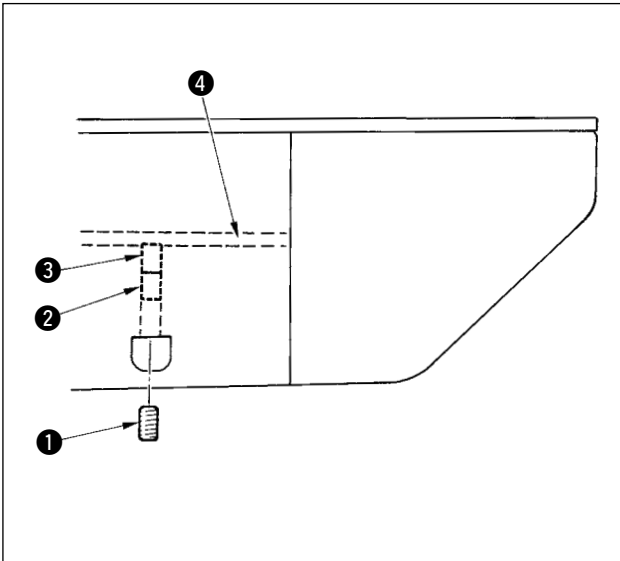

- 1) Loosen setscrew ① and remove setscrew ①.
- 2) When screwing in adjustment screw ②, the amount of oil of oil pipe, left ④ can be reduced.
- 3) After the adjustment, screw in setscrew ① and fix it.

1. The state of standard delivery is the position where ③ is lightly screwed in and returned by 4 turns.

2. When reducing the amount of oil, do not screw in the screw at once. Observe the state for approximately half a day at the position where ③ is screwed in and returned by 2 turns. If reducing is excessive, worn-out of the hook will result.



## 1-10. Replacing the fuse

### WARNING :



1. To avoid electrical shock hazards, turn OFF the power and open the control box cover after about five minutes have passed.
2. Open the control box cover after turning OFF the power without fail. Then, replace with a new fuse with the specified capacity.

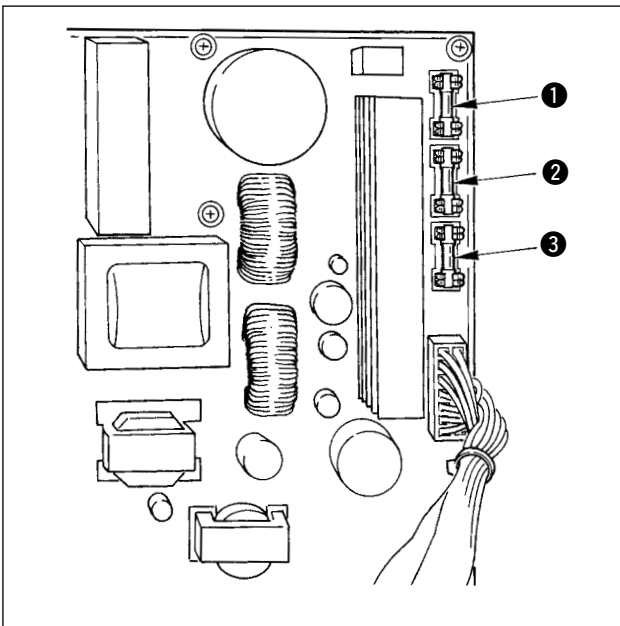

The machine uses the following three fuses :

- ① For pulse motor power supply protection  
15A (time-lag fuse)
- ② For solenoid and pulse motor power supply protection  
3.15A (time-lag fuse)
- ③ For control power supply protection  
2A (fast-blow type fuse)

## 1-11. Changing the voltage of 100 $\longleftrightarrow$ 200V



### WARNING :

To prevent personal injuries caused by electric shock hazards or abrupt start of the sewing machine, carry out the work after turning OFF the power switch and a lapse of 5 minutes or more. To prevent accidents caused by unaccustomed work or electric shock, request the electric expert or engineer of our dealers when adjusting the electrical components.

It is adaptable to the voltage of single phase 100V to 120V/3-phase 200V to 240V by changing the voltage changeover connector mounted on FLT p.c.b.

**(Caution) When the changing procedure is wrong, the control box will be broken. So, be very careful.**

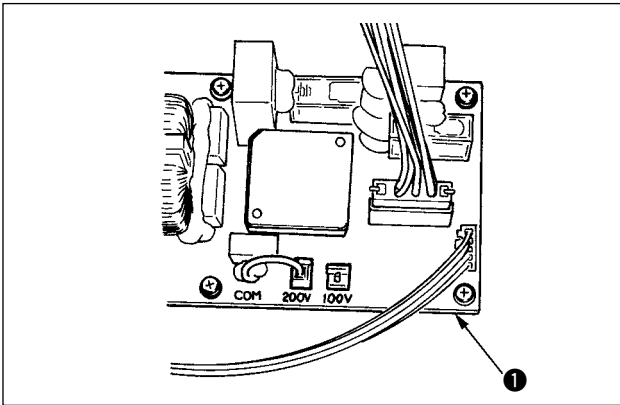

Changing procedure of the changeover connector

1. Turn OFF the power source with the power switch after confirming that the sewing machine has stopped.
2. Draw out the power cord from the power plug socket after confirming that the power switch is turned OFF. Then wait for five minutes or more.
3. Remove the front cover.
4. Remove four screws fixing the rear cover of the control box and slowly open the rear cover.

#### A. In case of using with 3-phase 200V to 240V

- Changing the changeover connector  
Connect to 200V the 100/200V changeover connector of FLT p.c.b. ❶ located on the side of the Box Side of the control box.
- Connect the crimp style terminal of AC input cord to the power plug as shown in the figure.

#### B. In case of using with single phase 100V to 120V

- Changing the changeover connector  
Connect to 100V the 100/200V changeover connector of FLT p.c.b. ❶ located on the side of the Box Side of the control box.
- Connect the crimp style terminal of AC input cord to the power plug as shown in the figure.

**(Caution) Securely perform the insulation treatment to the red terminal which is not used with insulation tape or the like. (When the insulation is insufficient, there is a danger of electric shock or leakage current.)**

#### C. In case of using with single phase 200V to 240V

- Changing the changeover connector  
Connect to 200V the 100/200V changeover connector of FLT p.c.b. ❶ located on the side of the Box Side of the control box.
- Connect the crimp style terminal of AC input cord to the power plug as shown in the figure.

**(Caution) Securely perform the insulation treatment to the red terminal which is not used with insulation tape or the like. (When the insulation is insufficient, there is a danger of electric shock or leakage current.)**

5. Check that the change has been performed without fail before closing the rear cover.
6. Be careful that the cord is not pinched between the rear cover and the control box main unit. Close the rear cover while pressing the lower side of rear cover, and tighten four screws.

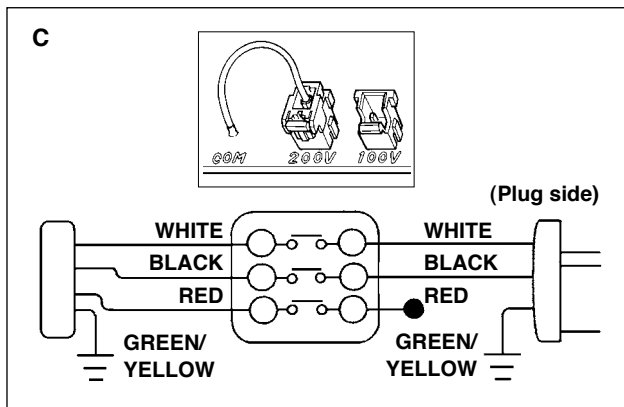
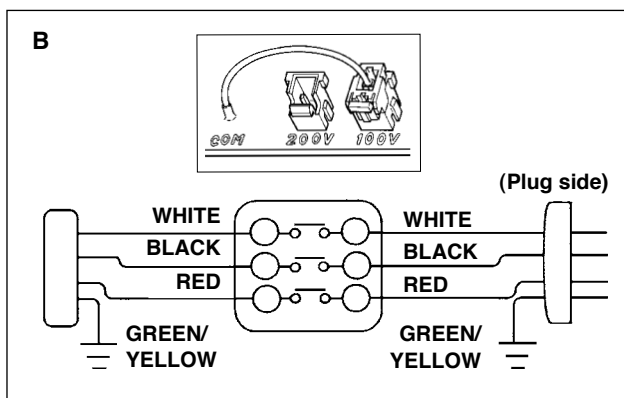
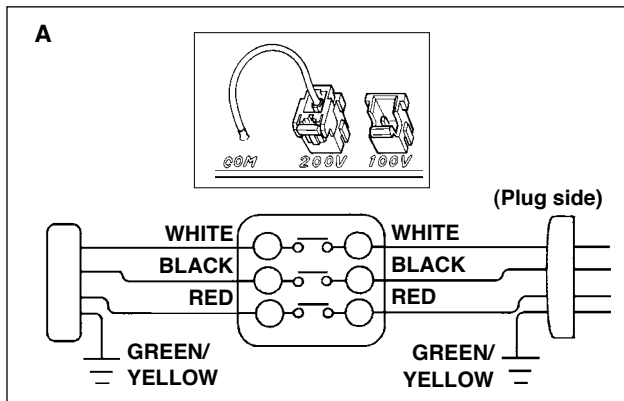

## 1-12. Replenishing the designated places with grease

[When using IP-410]

- \* Perform grease supplement when the errors below are displayed or once a year (either one which is earlier).

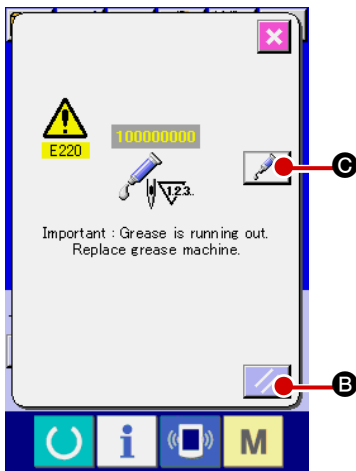

When the sewing machine has been used for a certain number of stitches, error "E220 Grease-up warning" is displayed. This display informs the operator of the time of replenishing the designated places with grease. Be sure to replenish the places with the grease below. Then call the memory switch U245, press CLEAR button **C** **A** and set NUMBER OF STITCHES **D** to "0".

Even after the display of the error "E220 Grease-up warning", when RESET key  **B** is pressed, the error is released, and the sewing machine can be continuously used. Afterwards, however, error code "E220 Grease-up warning" is displayed every time the power is re-turning ON.

In addition, when the sewing machine is used further for a certain period of time without replenishing the places with grease after the display of error No. E220, error "E221 Grease-up error" is displayed and the sewing machine fails to operate since the error cannot be released even when the RESET key is pressed.

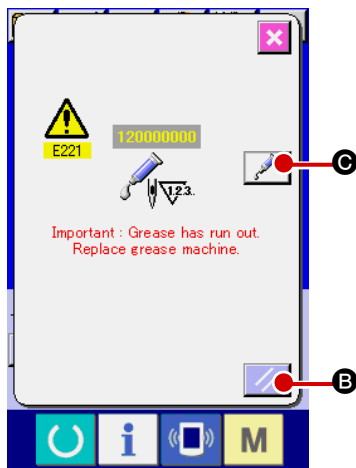

When error "E221 Grease-up error" is displayed, be sure to replenish the designated places below with grease. Then call the memory switch U245, press CLEAR button **C** **A** and set NUMBER OF STITCHES **D** to "0".

When RESET key  **B** is pressed without replenishing the designated places with grease, error code "E221 Grease-up warning" is displayed every time the power is re-turning ON afterwards and the sewing machine fails to operate. So, be careful.

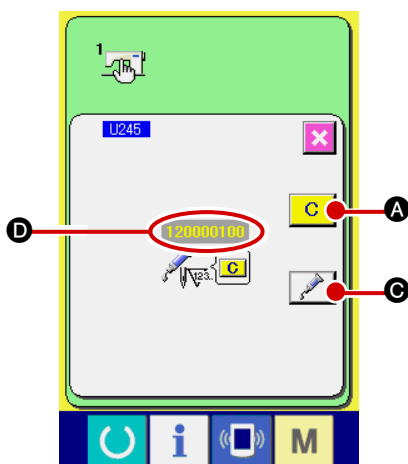

1. Error code E220 or E221 is displayed again unless NUMBER OF STITCHES **D** is changed to "0" after replenishing the designated places with grease. When E221 is displayed, the sewing machine fails to operate. So, be careful.
2. When GREASE APPLYING POSITION DISPLAY button  **C** is pressed in each screen, the grease applying position can be confirmed in the panel display. Be sure, however, to perform the grease applying after turning OFF the power.

**[When using CP-20]**

- \* **Perform grease supplement when the errors below are displayed or once a year (either one which is earlier). After performing grease supplement, call memory switch No. 245 and set the value to "0" with the reset key.**

When the sewing machine has been used for a certain number of times of sewing, error code No. E220 is displayed on the operation panel at the time of turning ON the power. This display informs the operator of the time of replenishing the designated places with grease. Be sure to replenish the places with the grease below. Then call the memory switch No. 245 and set it to "0" with the RESET key.

Even after the display of the error No. E220, when the RESET key is pressed, the error is released, and the sewing machine can be continuously used. Afterwards, however, the error No. E220 is displayed every time the power is turned ON.

In addition, when the sewing machine is used further for a certain period of time without replenishing the designated places with grease after display of error No. E220, error No. E221 is displayed and the sewing machine fails to operate since the error cannot be released even when the RESET key is pressed. When the error No. E221 is displayed, be sure to replenish the designated places below with grease. Then start up the memory switch and set No. 245 to "0" with the RESET key.



**After replenishing the places with grease, the error No. E220 or No. E221 is displayed again unless the memory switch No. 245 is changed to "0".**



**WARNING :**

**Turn OFF the power before starting the work so as to prevent accidents caused by abrupt start of the sewing machine.**



**Use grease tube (Part No. 40013640) supplied as accessories to replenish the designated places below with grease. If grease other than the designated one is replenished, damage of components will be caused.**

**(1) Replenishing the eccentric cam section with grease**

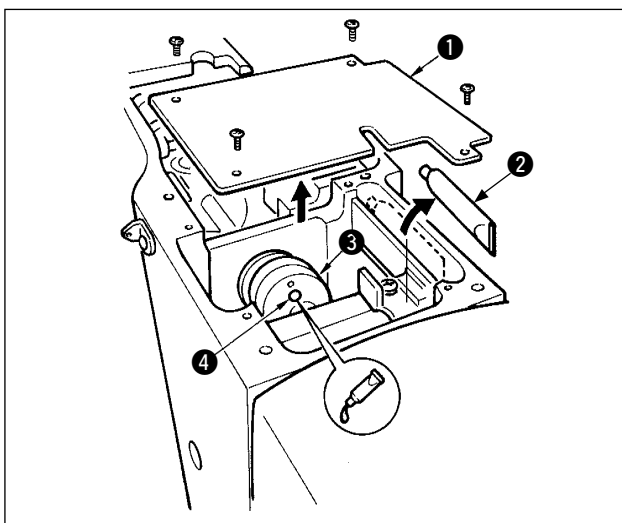

- 1) Open the upside cover **①** and remove the grease **②**.
- 2) Remove rubber cap **④** located on the side of eccentric cam **③**. Then replenish there with grease.

## (2) Replenishing the oscillator pin section with grease

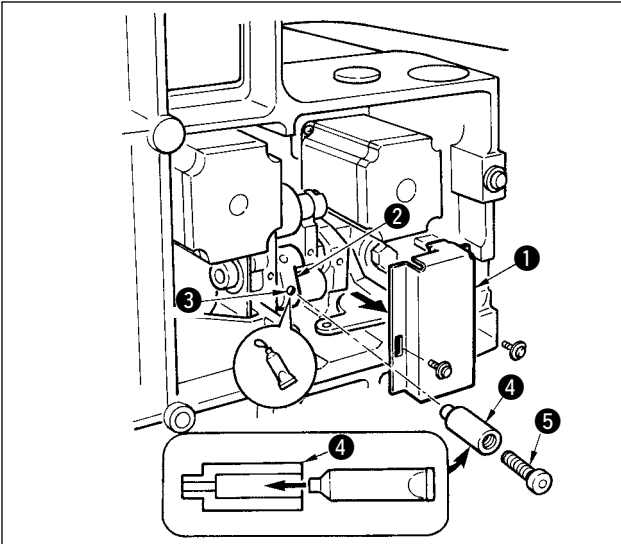

- 1) Tilt the machine head and remove the grease cover **1**.
- 2) Fill joint **4** supplied as accessories with grease from the grease tube.
- 3) Remove setscrew **3** in oscillator gear **2** and screw in joint **4** into the screw hole.
- 4) Screw in screw **5** supplied as accessories to the joint and replenish there with the grease.
- 5) Securely tighten setscrew **3** which has been removed after replenishing with the grease.

## (3) Grease supplement to the face plate section

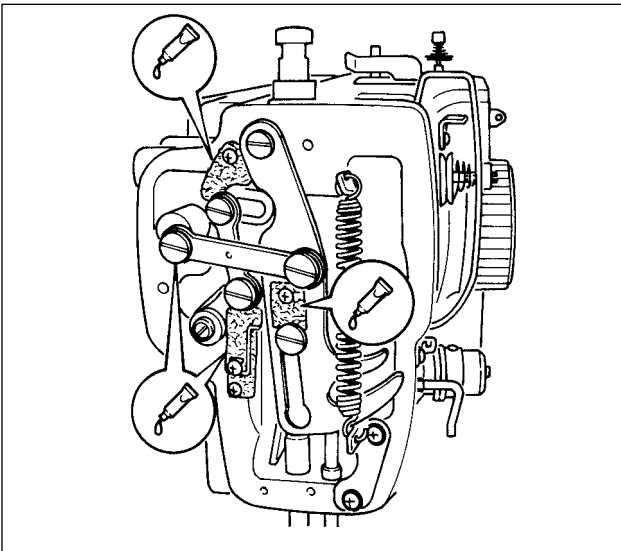

- 1) Open the face plate cover.
- 2) Supplement grease to the felt section (3 places) and the hinge screws around them.

## (4) Grease supplement to X guide shaft bearing

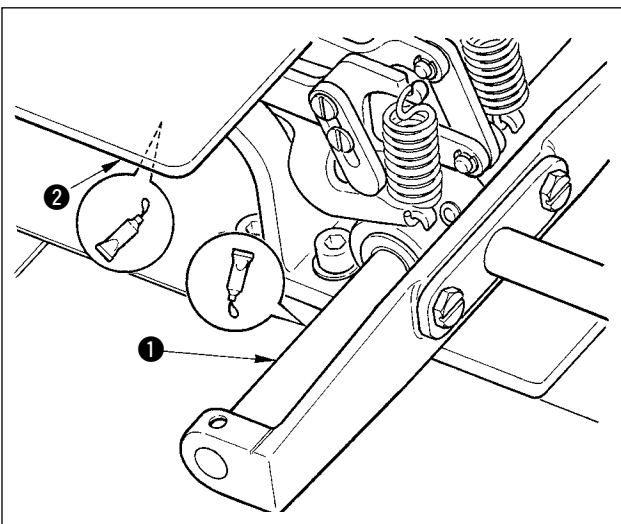

- 1) Apply grease to X guide shaft **1** and the rear of presser plate **2**.

### 1-13. Troubles and corrective measures (Sewing conditions)

Trouble	Cause	Corrective measures	Page
1. The needle thread slips off at the start of bartacking.	① Stitches are slipped at the start.	○ Adjust the clearance between the needle and the shuttle to 0.05 to 0.1 mm.	121
	② The needle thread remaining on the needle after thread trimming is too short.	○ Set soft-start sewing at the start of bartacking.	104
	③ The bobbin thread is too short.	○ Correct the thread tension release timing of the thread tension controller No. 2.	22
	④ Needle thread tension at 1st stitch is too high.	○ Increase the tension of the thread take-up spring, or decrease the tension of the thread tension controller No. 1.	20
	⑤ Thread clamp is unstable (material is apt to be expanded, thread is hard to slide, thread is thick, etc.).	○ Decrease the tension of the bobbin thread.	124
	⑥ Pitch at 1st stitch is too small.	○ Increase the clearance between the needle hole guide and the counter knife. ○ Decrease the tension at 1st stitch. ○ Decrease the number of rotation at 1st stitch at the sewing start. (Extent of 600 to 1,000 rpm) ○ Increase the number of stitches of thread clamp to 3 to 4 stitches. ○ Make the pitch at 1st stitch longer. ○ Decrease the needle thread tension at 1st stitch.	
2. Thread often breaks or synthetic fiber thread splits finely.	① The shuttle or the driver has scratches.	○ Take it out and remove the scratches using a fine whetstone or buff.	21
	② The needle hole guide has scratches.	○ Buff or replace it.	
	③ The needle strikes the work clamp foot.	○ Correct the position of the work clamp foot.	20
	④ Fibrous dust is in the groove of the shuttle race.	○ Take out the shuttle and remove the fibrous dust from the shuttle race.	
	⑤ The needle thread tension is too high.	○ Reduce the needle thread tension.	22
	⑥ The tension of the thread take-up spring is too high.	○ Reduce the tension.	133
	⑦ The synthetic fiber thread melts due to heat generated on the needle.	○ Use silicone oil.	
	⑧ When taking up thread, thread is pierced with needle tip.	○ Lower the needle bar height from the engraved marker line by a half of the line to as much as the line. ○ Check the rough state of needle tip. ○ Use the ball-pointed needle.	
3. The needle often breaks.	① The needle is bent.	○ Replace the bent needle.	18
	② The needle hits the work clamp foot.	○ Correct the position of the work clamp foot.	21
	③ The needle is too thin for the material.	○ Replace it with a thicker needle according to the material.	121
	④ The driver excessively bends the needle.	○ Correctly position the needle and the shuttle.	
4. Threads are not trimmed.  (Bobbin thread only)	① The counter knife is dull.	○ Replace the counter knife.	124
	② The difference in level between the needle hole guide and the counter knife is not enough.	○ Increase the bend of the counter knife.	
	③ The moving knife has been improperly positioned.	○ Correct the position of the moving knife.	121
	④ The last stitch is skipped.	○ Correct the timing between the needle and the shuttle.	
	⑤ Bobbin thread tension is too low.	○ Increase the bobbin thread tension.	
	⑥ Flopping of cloth	○ Lower the intermediate presser height of the last stitch.	

Trouble	Cause	Corrective measures	Page
5. Stitch skipping often occurs.	<ul style="list-style-type: none"> <li>① The motions of the needle and shuttle are not properly synchronized.</li> <li>② The clearance between the needle and shuttle is too large.</li> <li>③ The needle is bent.</li> <li>④ The driver excessively bends the needle.</li> </ul>	<ul style="list-style-type: none"> <li>○ Correct the positions of the needle and shuttle.</li> <li>○ Correct the positions of the needle and shuttle.</li> <li>○ Replace the bent needle.</li> <li>○ Correctly position the driver.</li> </ul>	121 121 18 121
6. The needle thread comes out on the wrong side of the material.	<ul style="list-style-type: none"> <li>① The needle thread tension is not high enough.</li> <li>② The tension release mechanism fails to work properly.</li> <li>③ The needle thread after thread trimming is too long.</li> <li>④ Number of stitches is too few.</li> <li>⑤ When sewing length is short (End of needle thread protrudes on the wrong side of sewing product.)</li> <li>⑥ Number of stitches is too few.</li> </ul>	<ul style="list-style-type: none"> <li>○ Increase the needle thread tension.</li> <li>○ Check whether or not the tension disc No. 2 is released during bar-tracking.</li> <li>○ Increase the tension of the thread tension controller No. 1.</li> <li>○ Correct the position of the moving knife.</li> <li>○ Turn OFF the thread clamp.</li> <li>○ Turn OFF the thread clamp.</li> <li>○ Use the lower plate, the hole of which is larger than the presser.</li> </ul>	20 20
7. Thread end of the 1st stitch comes out on the right side of the material.	<ul style="list-style-type: none"> <li>① Stitch skipping at the 1st stitch</li> <li>② Needle used and thread used are thick in terms of the inner diameter of the intermediate presser.</li> <li>③ Intermediate presser is not properly positioned in terms of the needle.</li> </ul>	<ul style="list-style-type: none"> <li>○ Adjust the hook timing faster by a 1/2 stitch.</li> <li>○ Increase the inner diameter of intermediate presser.</li> <li>○ Adjust the eccentricity between intermediate presser and needle so that needle enters in the center of intermediate presser.</li> </ul>	
8. Threads break at time of thread trimming.	<ul style="list-style-type: none"> <li>① The moving knife has been improperly position.</li> </ul>	<ul style="list-style-type: none"> <li>○ Correct the position of the moving knife.</li> </ul>	124
9. The thread clamp is entangled with needle thread.	<ul style="list-style-type: none"> <li>① The needle thread at the sewing start is too long.</li> </ul>	<ul style="list-style-type: none"> <li>○ Tighten thread tension controller No. 1 and make the length of needle thread 40 to 50 mm.</li> </ul>	24
10. Uneven length of the needle thread	<ul style="list-style-type: none"> <li>① The tension of thread take-up spring is too low.</li> </ul>	<ul style="list-style-type: none"> <li>○ Increase the tension of the thread take-up spring.</li> </ul>	22
11. The length of needle thread does not become short.	<ul style="list-style-type: none"> <li>① The tension of thread tension controller No. 1 is too low.</li> <li>② The tension of thread take-up spring is too high.</li> <li>③ The tension of thread take-up spring is too low and motion is unstable.</li> </ul>	<ul style="list-style-type: none"> <li>○ Increase the tension of thread tension controller No. 1.</li> <li>○ Decrease the tension of thread take-up spring.</li> <li>○ Increase the tension of thread take-up spring and lengthen the stroke as well.</li> </ul>	20 22
12. The knotting section of bobbin thread at 2nd stitch at the sewing start appears on the right side.	<ul style="list-style-type: none"> <li>① Idling of bobbin is large.</li> <li>② The bobbin thread tension is too low.</li> <li>③ The needle thread tension at 1st stitch is too high.</li> </ul>	<ul style="list-style-type: none"> <li>○ Adjust the position of the moving knife.</li> <li>○ Increase the bobbin thread tension.</li> <li>○ Decrease the needle thread tension at 1st stitch.</li> <li>○ Turn OFF the thread clamp.</li> </ul>	124 20
13. Wiper fails to work. (Return is defective.)	<ul style="list-style-type: none"> <li>① Needle entry of the last needle is the same as that of the sewing start, and the resistance of thread and cloth is large.</li> </ul>	<ul style="list-style-type: none"> <li>○ Shift the needle entry point of the last needle.</li> </ul>	



## 2. OPTIONAL

### 2-1. Table of Needle hole guide

Needle used Size	Needle hole guide		
	Part No.	Needle hole diameter	Application
#09 to #11	B242621000C	ø 1.6	For knits (OP)
#11 to #14 *1	B242621000A	ø 1.6	For light-weight to medium-weight materials (S type)
#14 to #18 *2	B242621000B	ø 2.0	For medium-weight to heavy-weight materials (H type)
#18 to #21	B242621000D	ø 2.4	For heavy-weight materials (OP)
	B242621000F	ø 3.0	
#22 to #25	B242621000G	ø 3.0 (with a counterbore)	For extra heavy-weight materials (OP)
#18 to #25	B242621000H	ø 3.0 (eccentric hole)	For heavy-weight materials to prevent skip-stitching (OP)

Needle used Size	Intermediate presser	
	Part No.	Size (øA × øB × H × L)
#09 to #11	B1601210D0E (OP)	ø 1.6 × ø 2.6 × 5.7 × 37.0
#11 to #14 *1	40023632 (Standard)	ø 2.2 × ø 3.6 × 5.7 × 38.5
#14 to #18 *2	B1601210D0FA (OP)	ø 2.2 × ø 3.6 × 8.7 × 41.5
#18 to #21	B1601210D0BA (OP)	ø 2.7 × ø 4.1 × 5.7 × 38.5
#22 to #25	B1601210D0CA (OP)	ø 3.5 × ø 5.5 × 5.7 × 38.5
#18 to #25		

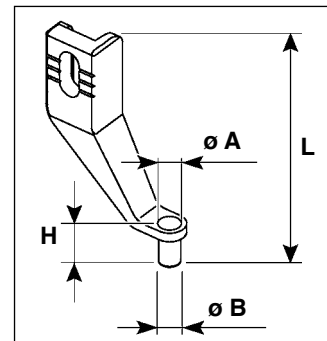

- \* 1 : Standard installed needle (DP X 5 #14)
- \* 2 : Standard installed needle (DP X 17 #18)
- S type : Applicable count of thread : #80 to #20
- H type : Applicable count of thread : #50 to #02
- (OP) means the optional.

### 2-2. Silicon oil tank



#### WARNING :

Turn OFF the power before starting the work so as to prevent accidents caused by abrupt start of the sewing machine.

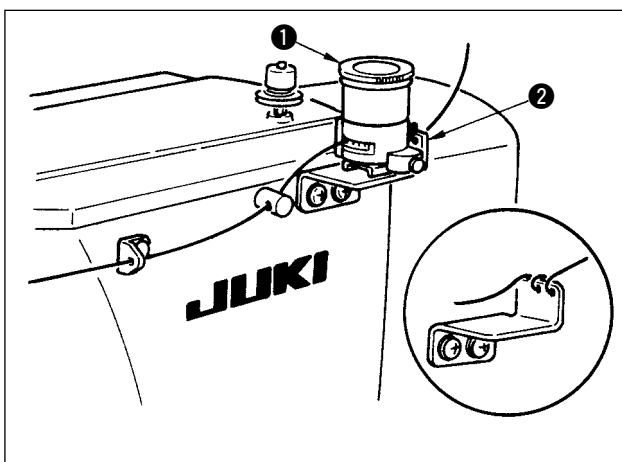

Fix silicon oil tank ① (MAXAP30EX00) with the magnet.



1. If the thread twists hard on silicon oil tank base ② (B2535210000), reverse the direction of winding the thread.
2. For fixing the silicon oil tank base, use two M4 screws. (Part No. of commendable screw : SM4040855SP)